



Pentium® II Processor Server Performance Brief



May 1997

Order Number: 243385-001

Information in this document is provided in connection with Intel products. No license, express or implied, by estoppel or otherwise, to any intellectual property rights is granted by this document. Except as provided in Intel's Terms and Conditions of Sale for such products, Intel assumes no liability whatsoever, and Intel disclaims any express or implied warranty, relating to sale and/or use of Intel products including liability or warranties relating to fitness for a particular purpose, merchantability, or infringement of any patent, copyright or other intellectual property right. Intel products are not intended for use in medical, life saving, or life sustaining applications.

Intel may make changes to specifications and product descriptions at any time, without notice.

Designers must not rely on the absence or characteristics of any features or instructions marked "reserved" or "undefined." Intel reserves these for future definition and shall have no responsibility whatsoever for conflicts or incompatibilities arising from future changes to them.

The Pentium®II Processor may contain design defects or errors known as errata which may cause the product to deviate from published specifications. Such errata are not covered by Intel's warranty. Current characterized errata are available on request .

*Third-party brands and names are the property of their respective owners.

Contact your local Intel sales office or your distributor to obtain the latest specifications and before placing your product order.

Copies of documents which have an ordering number and are referenced in this document, or other Intel literature, may be obtained from:

Intel Corporation
P.O. Box 7641
Mt. Prospect, IL 60056-7641

or call 1-800-879-4683

COPYRIGHT © INTEL CORPORATION 1996



CONTENTS

	PAGE
1.0 INTRODUCTION.....	5
2.0 SERVERBENCH*	6
3.0 DISCUSSION OF RESULTS	7
4.0 SYSTEM CONFIGURATION	8



1.0 INTRODUCTION

The purpose of this report is to provide a performance comparison between the Pentium® II processor and the Pentium Pro processor at the processor level. Because each processor utilizes a different and non-compatible package technology, it is necessary that different base platforms be utilized in order to obtain results. Except for the base platform, all other elements of the testing remained the same including the I/O subsystem, chipset (440FX), system main memory, operating system and network configuration.

The Intel uniprocessor “Rosewood” (see Table 3) platform was utilized for the Pentium Pro processor testing and the uniprocessor Intel “Portland” (see Table 2) platform was utilized for the Pentium II processor testing.

Dual processor (DP) testing is in progress, but is delayed due to the fact that Intel is relying on outside suppliers for DP 440FX Pentium II processor platforms and the system stability of these platforms is not yet permitting accurate benchmark results. It is anticipated these results will be available in 4 to 6 weeks.

Additional testing in progress includes 440LX based platforms with SDRAM. These results will also be available in 4 to 6 weeks.

The Pentium® II processor is a high-performance microprocessor which is fully software-compatible with previous generations of Intel microprocessors. The differences in the Pentium II processor as compared to the Pentium Pro processor include:

- Higher frequency implementations
- A half-speed, off-chip L2 cache using pipelined burst SRAM (PBSRAM)
- L1 instruction and data cache sizes doubled to 16 Kbytes each
- A SIMD execution unit for support of MMX™ technology
- Validated for dual and uniprocessor configurations only

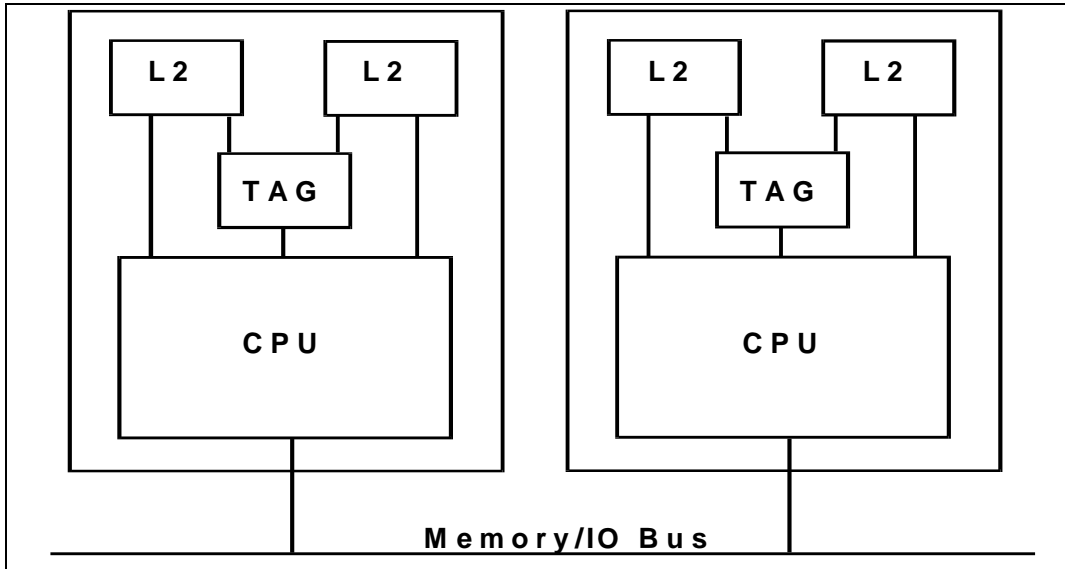

Figure 1. The Pentium® II Processor has Separate Interfaces to its L2 Cache and to the Memory/IO Bus

The Pentium II processor includes an off-chip, non-blocking four way set associative L2 cache of 512 Kbyte (shown in Figure 1-1). (Later releases may offer different cache sizes.) Focus in this document is placed on measuring the performance of Pentium II processor-based servers (compared to the performance of Pentium Pro processor-based servers) through the most common server benchmark ServerBench*.

2.0 SERVERBENCH*

ServerBench is a Ziff-Davis benchmark that lets you measure the performance of a server in a client/server environment. ServerBench produces numerous results. One of its primary results is an overall ServerBench score for a server. ServerBench's test setup is similar to an application server environment. In this environment, data and applications exist on the server. The client PCs are primarily a front-end to provide an access point into the applications.

ServerBench* comes in three main parts:

1. The first part is a specially written piece of software that can stress any or all of the three main subsystems of a server: the processor, disk, and network. Instead of running server-based applications, ServerBench* uses its own programs to exercise a server. The processor test behaves much like the processor-intensive portions of typical database servers. The test includes data searches, sorts, and integer arithmetic. During its work each processor test program consumes about 400 Kbytes of RAM on the server.

2. The client software lets the clients ask for a mix of processor, disk, and network services. The disk tests can perform random or sequential read or write operations, as well as file appends. ServerBench lets the tester determine such characteristics as the size of the test file each client uses, the size of the chunks in which the test moves data, and the placement of the files on the server's disks.

Testers control the whole show from a single PC that runs the controller software. The network tests basically read and write data to the server using the client-to-server network connection. Like the disk tests, the network tests let testers determine key test parameters, such as the total amount of data to move over the network and the size of the chunks the data should move

ServerBench lets the tester determine the exact blend of requests the clients make of the servers. Tests can involve requests that hit only single server subsystem, such as the disk subsystem, or a mixture of all three subsystems and varying numbers of clients.

ServerBench reports its test results as ServerBench transactions per second (TPS). It combines the TPS scores for different transactions using a weighted harmonic mean.

More information about ServerBench can be obtained from the Ziff-Davis Benchmark Operation Web page at <http://www.zdnet.com/zdbop/svrbench/svrbench.html>

3.0 DISCUSSION OF RESULTS

Serverbench 3.0 was run with Windows* NT 4.0 ServerBuild* 1381 (including Service pack 2), configured as a network application server. The server's disk I/O configuration consisted of a single boot disk, and 8x1GB RAID 0 used as the target device for the benchmark by eight clients. The 8x1GB RAID 0 was split across two I/O channels of four disks each. The server's networking consisted of two PRO100B NICs at 100 Mbs. TCP/IP network protocol was used for connectivity between all clients, server and Serverbench controller.

The network was split into two segments of four clients each accessing a PRO100B card on the server. This is done to balance the network load. To further balance network load, odd and even clients are separated each to their own network segment.

Two Pentium II processor-based configurations - Pentium processor II/512K 233 MHz and Pentium processor II/512K 266 MHz - were compared with two Pentium Pro processor configurations - Pentium Pro processor/255 K 200 MHz and Pentium Pro processor/512 K 200 MHz. All eight clients were using 133 MHz



Pentium processor-based systems running Windows* 95. The details about these server configurations are provided in Section 4.0.

The following table and chart show the results from the System Test Suite which includes processor, disk and network mixes.

Table 1. ServerBench* Scores

Processor	ServerBench Scores TPS	Ratio to Pentium® Pro Processor 200/256
Pentium Pro Processor 200/256K	202	100%
Pentium Pro Processor 200/512K	244	121%
Pentium II Processor 233/512	251	124%
Pentium II Processor 266/512	261	129%

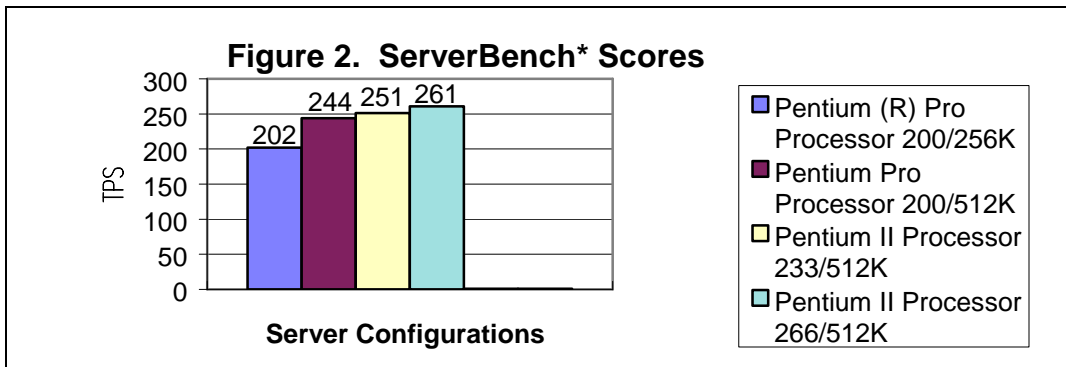

4.0 SYSTEM CONFIGURATION

Table 2. Pentium® II Processor-Based Server Configuration

Operating System:	Windows* NT - Uniprocessor Free
Version:	4.0 build 1381
Additional Info:	Service Pack 2, Large System Cache = 0
CPU/Memory:	
Processor Type:	GenuineIntel x86 Architecture P6 Family Model 3 Stepping 3 (Pentium® II Processor)
Processor Speed:	233 MHz/512K L2 and 266 MHz/512K L2
Number of CPUs:	1
Memory:	255 MByte
Additional Info:	PC/AT COMPATIBLE, System BIOS date: 02/12/97, PC Compatible Eisa/Isa HAL
Network Configuration:	<ol style="list-style-type: none"> 1. Intel 82557-based 10/100 Ethernet PCI Adapter, Intel, Intel 82557-based PRO Adapter Driver 2.0 2. Intel 82557-based 10/100 Ethernet PCI Adapter, Intel, Intel 82557-based PRO Adapter Driver 2.0
Disk Subsystem:	SCSI DiskPeripheral: ADAC LD 0 RAID 0 M.74, SCSI DiskPeripheral: ADAC LD 1 RAID 0 M.74, SCSI DiskPeripheral: ADAC LD 2 RAID 0 M.74, SCSI OtherPeripheral: CONNER CR6-RAID 2.300.00,

Table 3. Pentium® Pro Processor Server Configurations

Operating System:	Windows* NT - Uniprocessor Free
Version:	4.0 build 1381
Additional Info:	Service Pack 2, Large System Cache = 0
CPU/Memory:	
Processor Type:	Genuine Intel Architecture P6 Family Model 1 Stepping 7 (Pentium Pro Processor)
Processor Speed:	200 MHz/256K L2 and 200 MHz/512K L2
Number of CPUs:	1
Memory:	255 MByte
Additional Info:	PC/AT COMPATIBLE, System BIOS date: 02/12/97, PC Compatible Eisa/Isa HAL
Network Configuration:	<ol style="list-style-type: none"> 1. Intel 82557-based 10/100 Ethernet PCI Adapter, Intel, Intel 82557-based PRO Adapter Driver 2.0 2. Intel 82557-based 10/100 Ethernet PCI Adapter, Intel, Intel 82557-based PRO Adapter Driver 2.0
Disk Subsystem:	SCSI DiskPeripheral: ADAC LD 0 RAID 0 M.74, SCSI DiskPeripheral: ADAC LD 1 RAID 0 M.74, SCSI DiskPeripheral: ADAC LD 2 RAID 0 M.74, SCSI OtherPeripheral: CONNER CR6-RAID 2.300.00,

Table 4. Client Configurations (for All Eight Clients)

Operating System:	Windows* 95 - Uniprocessor Free
CPU/Memory:	Pentium®Processor
Processor Speed:	133 MHz
Number of CPUs:	1
Memory:	64 MByte
Additional Info:	PC/AT COMPATIBLE
Network Configuration:	Intel 82557-based 10/100 Ethernet PCI Adapter, Intel, Intel 82557-based PRO Adapter Driver 2.0
Disk Subsystem:	1.7 GB SCSI Drive