

Intel® Server Board S3000AH

Quick Start User's Guide

Thank you for buying the Intel® Server Board S3000AH. The following information will help you integrate your new server board into a server chassis. The Intel® Server Board S3000AH is supported in the Intel® Entry Server Chassis SC5295-E.

For details on this chassis or to select a third party chassis, please visit <http://www.intel.com/go/serverbuilder> and <http://support.intel.com/support/motherboards/server/chassis/sc5295-e>

When installing the server board into a reference chassis, refer to the reference chassis instructions.

User Guides are also available on the Intel® Server Deployment Toolkit 2.0 CD that accompanied your Intel® Server Board S3000AH.

If you are not familiar with ESD (Electrostatic Discharge) procedures used during system integration, please see the Intel® Server Board S3000AH User's Guide, available on the Intel® Server Deployment Toolkit 2.0 CD or at <http://support.intel.com/support/motherboards/server/s3000ah/howto.htm>

Read all cautions and warnings first before starting your server system integration.

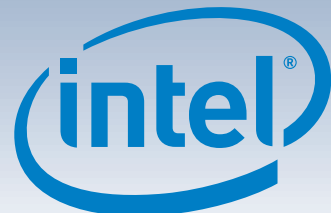

Minimum Hardware Requirements

To avoid integration difficulties and possible board damage, your system must meet the following minimum requirements:

- Processor: Intel® Pentium® processor Extreme Edition, Intel® Pentium® 4 processor, Intel® Pentium® D processor, Intel® Celeron® D processor with chassis compatible fan/heat sink.
- Memory Type: Minimum of one 512MB Unbuffered, 240-pin DDR2 533/667 MHz ECC and non-ECC memory DIMM.
- Power: Minimum of 350W with 2A of standby current, which meets the SSI EPS 12V specification.

1 Preparing the Chassis

When using an Intel® Server Chassis, begin with the Quick Start User's Guide that came with your chassis. Return to this document when directed by the server chassis Quick Start User's Guide. If using a non-Intel server chassis, refer to the documentation that came with your chassis for preparatory steps.

Observe normal ESD (ElectroStatic Discharge) procedures. Place your Intel® Server Chassis on a flat anti-static surface to perform the following integration procedures. Always touch the chassis frame first, before reaching inside to make server board connections or to install components.

2 Install the I/O Shield

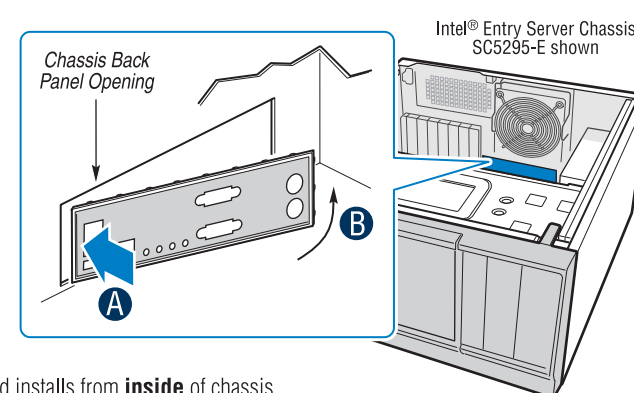

Shield installs from **inside** of chassis. The labels should be visible from the outside of the chassis.

- A Insert one side edge of shield as shown.
- B Push shield firmly into chassis opening until it clicks into place.

3 Install the Server Board

A. Install the Standoffs

Nine standoffs must be installed into the chassis before installing the server board. Locate the threaded standoff holes that match the server board, and install a standoff at each location indicated by the **RED** circles.

IMPORTANT NOTE: Verify that each server board mounting hole location has an installed standoff. Do not install a standoff at a location that does not have a corresponding server board mounting hole.

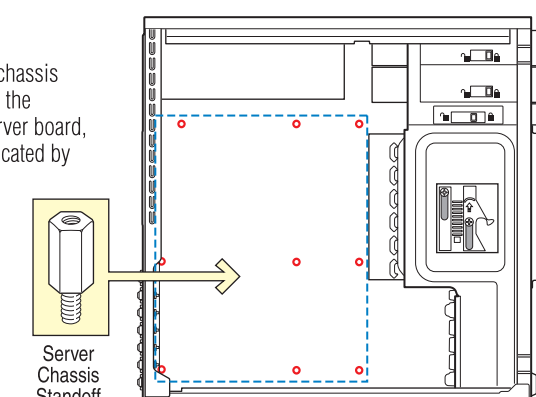

B. Insert the Server Board

Place the board into the chassis, making sure that back panel I/O ports and chassis I/O shield openings align correctly. Verify that server board mounting holes align correctly with the chassis standoffs.

When using the Intel® Entry Server Chassis SC5295-E, insert the I/O connector side (back) of the board first.

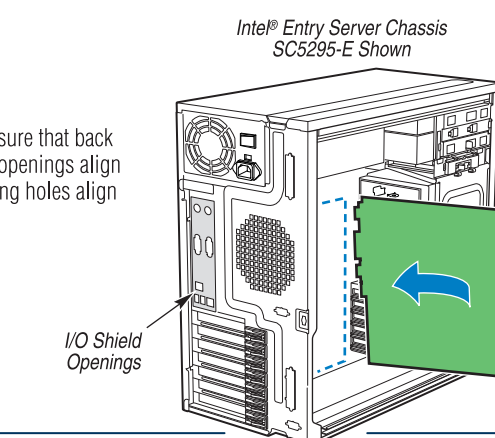

C. Attach the Server Board

Note: The Intel® Entry Server Chassis SC5295-E, and a non-Intel chassis may use different fasteners to attach the server board to the chassis. Use the fasteners that came with your chassis.

Use screws to attach the board to the chassis at the 9 locations indicated by the **RED** circles in the figure [○].

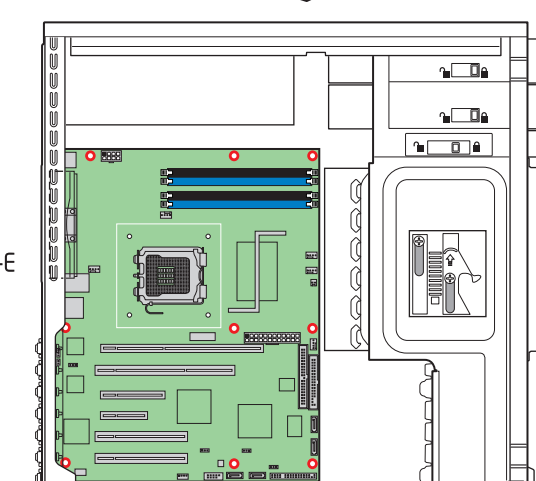

Warning

Read all caution and safety statements in this document before performing any of the instructions. Also see the Intel® Server Board and Server Chassis Safety Information document at: <http://support.intel.com/support/motherboards/server/sb/cs-010770.htm> for complete safety information.

Warning

Installation and service of this product should only be performed by qualified service personnel to avoid risk of injury from electrical shock or energy hazard.

Caution

Observe normal ESD (Electrostatic Discharge) procedures during system integration to avoid possible damage to server board and/or other components.

Tools Required

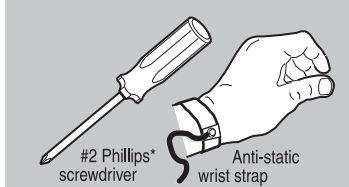

Intel is a registered trademark of Intel Corporation or its subsidiaries in the United States and other countries. *Other names and brands may be claimed as the property of others. Copyright © 2005, Intel Corporation. All rights reserved.

4 Install the Processor(s)

Notes and Cautions:

- 1. When opening a socket, DO NOT TOUCH the gold socket wires.
- 2. When unpacking a processor, hold by the edges only to avoid touching the gold contacts.

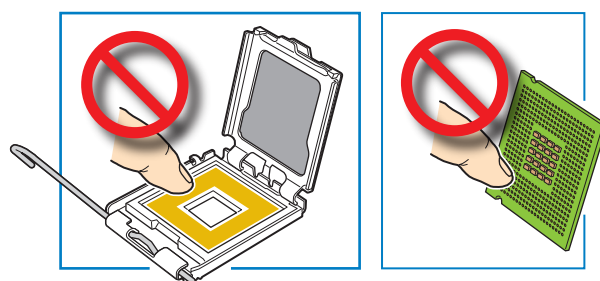

A. Open the Socket Lever

- A Push the lever handle down and away from the socket to release it.
- B Pull the lever and open all the way.

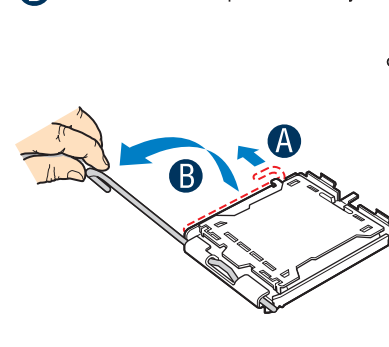

B. Open the Load Plate

- A Push the rear tab with your finger tip to bring the front end of the load plate up slightly.
- B Open the load plate as shown.

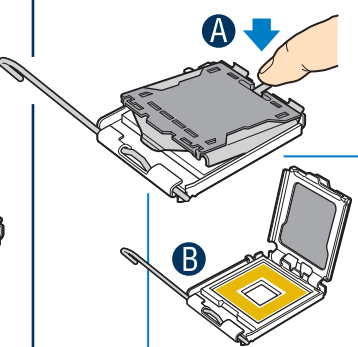

C. Remove the Processor Protective Cover

- A Take the processor out of the box and remove the protective shipping cover.



D. Install the Processor

CAUTION: The underside of the processor has components that may damage the socket pins if installed improperly. Processor must align correctly with socket opening before installation. DO NOT DROP processor into socket!

- A Orient the processor with the socket so that the processor cutouts match the socket notches.
- B Install the processor.

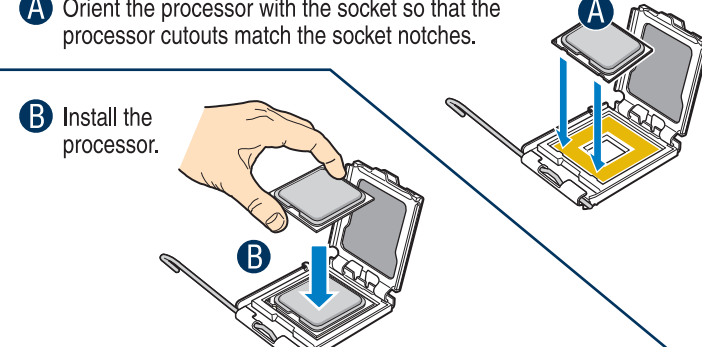

E. Remove Socket Protective Cover

- A Grasp the socket protective cover tab and pull away from the load plate as shown.
- B Remove the socket protective cover and store for future use.

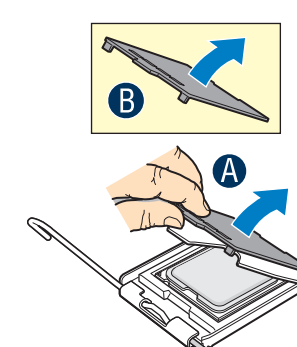

F. Close Load Plate and Socket Lever

- A Close the load plate all the way as shown.
- B With your finger, push down on the load plate as shown.
- C Close the socket lever and ensure that the load plate tab engages under the socket lever when fully closed.

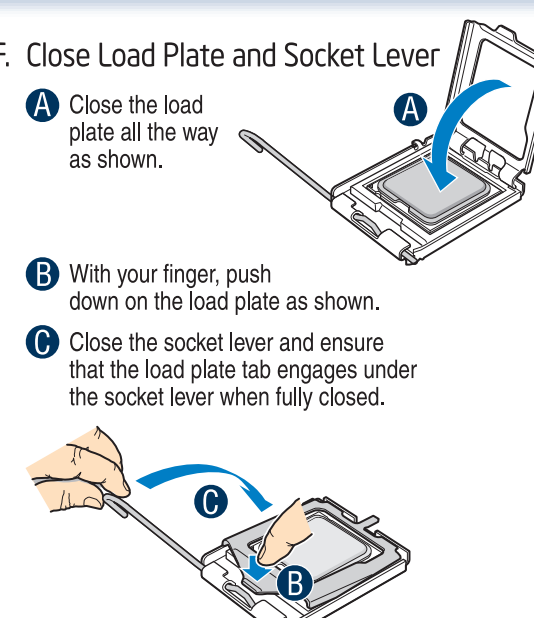

5 Install Active Heat Sink

An active heat sink is required for the Intel® Entry Server Chassis SC5295-E. A typical active heat sink is shown at right. Rotate the active heat sink so that the power connector can reach the CPU fan header on the server board.

CAUTION: The heat sink has thermal interface material (TIM) on the underside of it. Use caution so that you do not damage the thermal interface material. Use gloves to avoid sharp edges.

Use the following procedure to install an active heat sink to your server board:

- A Make sure the screwdriver slot at the top of each fastener is rotated perpendicular to the blades of the heat sink as shown.

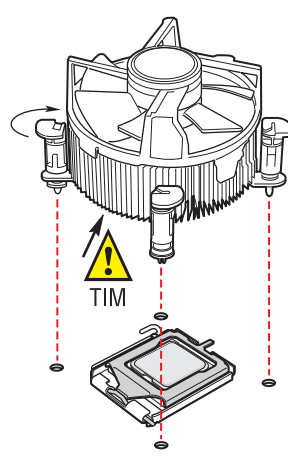

- B Align heat sink with holes in board and lower assembly to board. Snaps go through holes in server board.

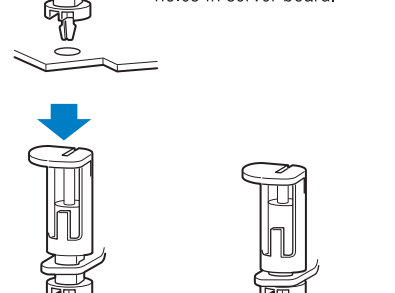

Repeat this procedure for each fastener.

D56210-002



6 Install Memory DIMMs

DDR2 DIMM Memory Identification:

This server board supports up to four DDR2-533 or DDR2-667 ECC or non-ECC unbuffered DIMMs. DDR DIMMs are not supported on this server board.

DDR2 memory varies in height. DO NOT MIX different DIMM heights and types.

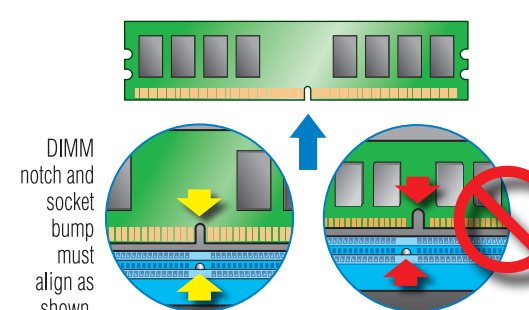

Memory Configurations and Population Order:

Memory Type: Minimum of one 512MB, DDR2 FB DIMM 533/667 MHz compliant 240-pin DIMM.

Populate DDR2 DIMMs in the order of 1A, 1B (blue sockets), then 2A and 2B (black sockets).

DIMMs must be identical with respect to size, speed, and organization.

Note: For additional memory configurations, see the User Guide on the CD that accompanied your Intel® Server Board S3000AH, or go to:

<http://support.intel.com/support/motherboards/server/S3000ah>

Memory sizing and configuration is supported only for qualified DIMMs approved by Intel®. For a list of supported memory, see the tested memory list at <http://support.intel.com/support/motherboards/server/s3000ah/compat.htm>

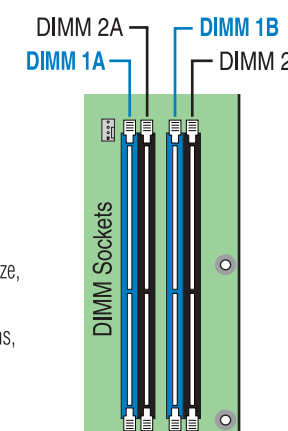

To Install DIMMs:

CAUTION: Avoid touching contacts when handling or installing DIMMs.

- A Open both DIMM socket levers.
- B Note location of alignment notch.
- C Insert DIMM making sure the connector edge of the DIMM aligns correctly with the slot.
- D Push down firmly on the DIMM until it snaps into place and both levers close.
- E **IMPORTANT!** Visually check that each latch is fully closed and correctly engaged with each DIMM edge slot.

