

Intel® Workstation Board S5000XVN

Technical Product Specification

Intel order number: D66403-006



Revision 1.5

August 2010

Enterprise Platforms and Services Division – Marketing

Revision History

Date	Revision Number	Modifications
August 2006	1.0	First production S5000XVN Technical Product Specification.
March 2007	1.1	<ul style="list-style-type: none"> ▪ Updated Table 1, Figure 1, and Section 3.1.2. ▪ Added Section 3.6.6. ▪ Updated Section 6.1 and 6.2. ▪ Updated Table 33, Appendix A and Table 44. ▪ Added Section 8.2.
June 2007	1.2	Updated to reflect new processor support and new product codes wherever applicable.
April 2009	1.3	<ul style="list-style-type: none"> ▪ Updated Section 6.3 BIOS Select Jumper. ▪ Updated the Front Panel SSI Standard 24-pin Connector Pin-out (J1E4) table. ▪ Updated Table 1 and Table 8. ▪ Removed 'dual-core' from the processor definition.
April 2010	1.4	Removed section 9.3.7 CNCA (CCC-China).
August 2010	1.5	Added Table 6 for quad rank memory and corrected the title of Table 16.

Disclaimers

Information in this document is provided in connection with Intel® products. No license, express or implied, by estoppel or otherwise, to any intellectual property rights is granted by this document. Except as provided in Intel's Terms and Conditions of Sale for such products, Intel assumes no liability whatsoever, and Intel disclaims any express or implied warranty, relating to sale and/or use of Intel products including liability or warranties relating to fitness for a particular purpose, merchantability, or infringement of any patent, copyright or other intellectual property right. Intel products are not intended for use in medical, life saving, or life sustaining applications. Intel may make changes to specifications and product descriptions at any time, without notice.

Designers must not rely on the absence or characteristics of any features or instructions marked "reserved" or "undefined." Intel reserves these for future definition and shall have no responsibility whatsoever for conflicts or incompatibilities arising from future changes to them.

The Intel® Workstation Board S5000XVN may contain design defects or errors known as errata which may cause the product to deviate from published specifications. Current characterized errata are available on request.

Intel Corporation server baseboards contain a number of high-density VLSI and power delivery components that need adequate airflow to cool. Intel's own chassis are designed and tested to meet the intended thermal requirements of these components when the fully integrated system is used together. It is the responsibility of the system integrator that chooses not to use Intel developed server building blocks to consult vendor datasheets and operating parameters to determine the amount of air flow required for their specific application and environmental conditions. Intel Corporation cannot be held responsible if components fail or the server board does not operate correctly when used outside any of their published operating or non-operating limits.

Intel, Pentium, Itanium, and Xeon are trademarks or registered trademarks of Intel Corporation.

*Other brands and names may be claimed as the property of others.

Copyright © Intel Corporation 2010.

Table of Contents

1. Introduction	1
1.1 Chapter Outline.....	1
1.2 Server Board Use Disclaimer	1
2. Overview	2
2.1 Workstation Board Feature Set	2
2.2 Workstation Board Layout	3
2.2.1 Workstation Board Connector and Component Layout	4
2.2.2 Workstation Board Mechanical Drawings	6
2.2.3 Workstation Board ATX I/O Layout.....	12
3. Functional Architecture	13
3.1 Intel® 5000X Memory Controller Hub (MCH)	14
3.1.1 System Bus Interface.....	14
3.1.2 Processor Support.....	14
3.1.3 Memory Subsystem	16
3.1.4 Snoop Filter	24
3.2 Enterprise South Bridge (ESB2-E)	24
3.2.1 PCI Subsystem	24
3.2.2 Serial ATA Support	26
3.2.3 Parallel ATA (PATA) Support	27
3.2.4 USB 2.0 Support.....	27
3.3 Audio Codec	28
3.4 SAS Controller	29
3.4.1 SAS RAID Support	29
3.4.2 SAS/SATA Connector Sharing	29
3.5 Network Interface Controller (NIC)	29
3.5.1 Intel® I/O Acceleration Technology (Intel® I/OAT).....	30
3.5.2 MAC Address Definition.....	30
3.6 Super I/O	31
3.6.1 Serial Ports	31
3.6.2 Floppy Disk Controller	31
3.6.3 Keyboard and Mouse Support	31
3.6.4 Wake-up Control.....	31
3.6.5 System Health Support.....	32
3.6.6 Trusted Platform Module (TPM)	32
4. Platform Management.....	33

5.	Connector/Header Locations and Pin-outs	35
5.1	Board Connector Information	35
5.2	Power Connectors	36
5.3	System Management Headers	37
5.3.1	LCP/AUX IPMB Header	37
5.3.2	IPMB Header	38
5.3.3	HSBP Header	38
5.3.4	SGPIO Header	38
5.3.5	SES I ² C	38
5.3.6	HDD Activity LED Header	38
5.4	Front Panel Connector	39
5.5	I/O Connectors	39
5.5.1	NIC Connectors	39
5.5.2	IDE Connector	40
5.5.3	SATA/SAS Connectors	41
5.5.4	Serial Port Connectors	41
5.5.5	Keyboard and Mouse Connector	42
5.5.6	USB Connector	42
5.5.7	CD-IN Header	43
5.5.8	Audio Connectors	43
5.6	Fan Headers	44
6.	Jumper Blocks	46
6.1	CMOS Clear and Password Reset Usage Procedure	47
6.2	BMC Force Update Procedure	47
6.3	BIOS Select Jumper	48
7.	Intel® Light Guided Diagnostics	49
7.1	5 Volt Standby LED	49
7.2	Fan Fault LEDs	50
7.3	System ID LED and System Status LED	51
7.3.1	System Status LED – BMC Initialization	53
7.4	DIMM Fault LEDs	53
7.5	Processor Fault LEDs	54
7.6	Post Code Diagnostic LEDs	54
8.	Design and Environmental Specifications	56
8.1	Intel® Workstation Board S5000XVN Design Specifications	56
8.2	Board-level MTBF	57

8.3	Workstation Board Power Requirements.....	57
8.3.1	Processor Power Support.....	59
8.4	Power Supply Output Requirements	59
8.4.1	Grounding	60
8.4.2	Standby Outputs	60
8.4.3	Remote Sense	60
8.4.4	Voltage Regulation	60
8.4.5	Dynamic Loading	61
8.4.6	Capacitive Loading	61
8.4.7	Ripple/Noise	62
8.4.8	Timing Requirements.....	63
8.4.9	Residual Voltage Immunity in Standby Mode	65
9.	Regulatory and Certification Information.....	66
9.1	Product Regulatory Compliance	66
9.1.1	Product Safety Compliance	66
9.1.2	Product EMC Compliance – Class A Compliance	66
9.1.3	Certifications/Registrations/Declarations	67
9.2	Product Regulatory Compliance Markings	67
9.3	Electromagnetic Compatibility Notices	68
9.3.1	FCC Verification Statement (USA)	68
9.3.2	ICES-003 (Canada)	68
9.3.3	Europe (CE Declaration of Conformity)	69
9.3.4	VCCI (Japan)	69
9.3.5	BSMI (Taiwan)	69
9.3.6	RRL (Korea).....	69
9.4	Restriction of Hazardous Substances (RoHS) Compliance.....	70
	Appendix A: Integration and Usage Tips.....	71
	Appendix B: BMC Sensor Tables	72
	Appendix C: POST Code Diagnostic LED Decoder	87
	Appendix D: POST Code Errors	91
	Appendix E: Supported Intel® Server Chassis	94
	Glossary.....	95
	Reference Documents	98

List of Figures

Figure 1. Workstation Board Photograph.....	3
Figure 2. Major Board Components.....	5
Figure 3. Mounting Hole Positions.....	6
Figure 4. Component Positions.....	7
Figure 5. Restricted Areas on Side 1.....	8
Figure 6. Restricted Areas on Side 2.....	9
Figure 7. Restricted Areas on Side 2, “Detail B”.....	10
Figure 8. CPU and Memory Duct Keepout.....	11
Figure 9. ATX I/O Layout.....	12
Figure 10. Functional Block Diagram.....	13
Figure 11. CEK Processor Mounting.....	16
Figure 12. Memory Layout.....	17
Figure 13. Minimum 2-DIMM Memory Configuration.....	21
Figure 14. Recommended Four DIMM Configuration.....	22
Figure 15. Single Branch Mode Sparing DIMM Configuration.....	23
Figure 16. Audio Subsystem Block Diagram.....	28
Figure 17. Rear I/O Panel Audio Connector.....	29
Figure 18. SMBUS Block Diagram.....	34
Figure 19. Jumper Blocks (J1C3, J1D1, J1D2, and J1E32).....	46
Figure 20. 5 Volt Standby Status LED Location.....	49
Figure 21. Fan Fault LED Locations.....	50
Figure 22. System ID LED and System Status LED Locations.....	51
Figure 23. DIMM Fault LED Locations.....	53
Figure 24. Processor Fault LED Locations.....	54
Figure 25. POST Code Diagnostic LED Location.....	55
Figure 26. Power Distribution Block Diagram.....	58
Figure 27. Output Voltage Timing.....	64
Figure 28. Turn On/Off Timing (Power Supply Signals).....	65
Figure 29. Diagnostic LED Placement Diagram.....	87

List of Tables

Table 1. Workstation Board Features	2
Table 2. Processor Support Matrix	14
Table 3. I ² C Addresses for Memory Module SMB	17
Table 4. Maximum Eight-DIMM System Memory Configuration – x8 Single Rank	18
Table 5. Maximum Eight-DIMM System Memory Configuration – x4 Dual Rank.....	18
Table 6. Maximum Eight-DIMM System Memory Configuration – x2 Quad Rank	18
Table 7. DIMM Population Rules	20
Table 8. PCI Bus Segment Characteristics.....	25
Table 9. NIC2 Status LED.....	30
Table 10. Serial B Header Pin-out	31
Table 11. Board Connector Matrix	35
Table 12. Power Connector Pin-out (J9B5)	36
Table 13. 12-V Power Connector Pin-out (J3J2)	37
Table 14. Power Supply Signal Connector Pin-out (J9D1)	37
Table 15. P12V4 Power Connector Pin-out (J5A2)	37
Table 16. LCP/AUX IPMB Header Pin-out (J2J1).....	37
Table 17. IPMB Header Pin-out (J4J1)	38
Table 18. HSBP Header Pin-out (J1J7, J1J2)	38
Table 19. SGPIO Header Pin-out (J2H1, J1J5).....	38
Table 20. SES I ² C Header Pin-out (J1J3).....	38
Table 21. HDD Activity LED Header Pin-out (J2J3).....	38
Table 22. Front Panel SSI Standard 24-pin Connector Pin-out (J1E4)	39
Table 23. RJ-45 10/100/1000 NIC Connector Pin-out (JA6A1, JA6A2).....	39
Table 24. IDE 40-pin Connector Pin-out (J2J2)	40
Table 25. SATA/SAS Connector Pin-out (J1J1, J1H2, J1H1, J1G2, J1G1, J1F2)	41
Table 26. External DB9 Serial A Port Pin-out (J7A1).....	41
Table 27. Internal 9-pin Serial B Header Pin-out (J1B1).....	42
Table 28. Stacked PS/2 Keyboard and Mouse Port Pin-out (J9A1)	42
Table 29. External USB Connector Pin-out (JA6A1, JA6A2).....	43
Table 30. Internal USB Connector Pin-out (J3J1).....	43
Table 31. CD-IN Header Pin-out (J4A1)	43
Table 32. SSI 4-pin Fan Header Pin-out (J9J1, J5J1, J9B3, and J9B4).....	44

Table 33. SSI 6-pin Fan Header Pin-out (J3H1, J3H2, J3H3, and J3H4).....	44
Table 34. Server Board Jumpers (J1C3, J1D1, J1D2, and J1E3)	46
Table 35. System Status LED	52
Table 36. Workstation Board Design Specifications	56
Table 37. Intel® Xeon® Processor Dual Processor TDP Guidelines	59
Table 38. 550 W Load Ratings	59
Table 39. Voltage Regulation Limits	61
Table 40. Transient Load Requirements.....	61
Table 41. Capacitive Loading Conditions	62
Table 42. Ripple and Noise.....	63
Table 43. Output Voltage Timing	63
Table 44. Turn On/Off Timing	64
Table 45. BMC Sensors.....	74
Table 46. POST Progress Code LED Example	87
Table 47. Diagnostic LED POST Code Decoder	88
Table 48. POST Error Messages and Handling.....	91
Table 49. POST Error Beep Codes	93
Table 50. BMC Beep Codes	93

<This page is intentionally left blank.>

1. Introduction

This Technical Product Specification (TPS) provides board-specific information about the features, functionality, and high-level architecture of the Intel® Workstation Board S5000XVN. See the *Intel® S5000 Server Board Family Datasheet* for details about board subsystems, including the chipset, BIOS, and server management.

In addition, design level information for specific subsystems can be obtained by ordering the External Product Specifications (EPS) for a given subsystem. EPS documents are not publicly available and must be ordered through your local Intel representative.

The Intel® Workstation Board S5000XVN may contain design defects or errors known as errata which may cause the product to deviate from published specifications. Refer to the Intel® Server Board S5000XVN Specification Update for published errata.

1.1 Chapter Outline

This document is divided into the following chapters

- Chapter 1 – Introduction
- Chapter 2 – Workstation Board Overview
- Chapter 3 – Functional Architecture
- Chapter 4 – Platform Management
- Chapter 5 – Connector and Header Location and Pin-out
- Chapter 6 – Configuration Jumpers
- Chapter 7 – Light-Guided Diagnostics
- Chapter 8 – Power and Environmental specifications
- Chapter 9 – Regulatory and Certification Information
- Appendix A – Integration and Usage Tips
- Appendix B – BMC Sensor Tables
- Appendix C – POST Code Diagnostic LED Decoder
- Appendix D – POST Code Errors
- Appendix E – Supported Intel® Server Chassis
- Glossary
- Reference Documents

1.2 Server Board Use Disclaimer

Intel Corporation server boards support add-in peripherals and contain a number of high-density VLSI and power delivery components that need adequate airflow to cool. Intel ensures through its own chassis development and testing that when Intel server building blocks are used together, the fully integrated system will meet the intended thermal requirements of these components. It is the responsibility of the system integrator who chooses not to use Intel-developed server building blocks to consult vendor datasheets and operating parameters to determine the amount of air flow required for their specific application and environmental conditions. Intel Corporation cannot be held responsible if components fail or the server board does not operate correctly when used outside any of their published operating or non-operating limits.

2. Overview

The Intel® Workstation Board S5000XVN is a monolithic printed circuit board (PCB) with features that support the pedestal workstation market.

2.1 Workstation Board Feature Set

Table 1. Workstation Board Features

Feature	Description
Processors	Socket J (771-pin LGA sockets) supporting one or two Intel® Xeon® processors 5000 sequence, with system bus speeds of 667 MHz, 1066 MHz, and 1333 MHz.
Memory	Eight DIMM sockets supporting fully buffered DIMM technology (FBDIMM) memory. 240-pin DDR2-533 and DDR2-677 FBDIMMs can be used.
Chipset	<ul style="list-style-type: none"> ▪ Intel® 5000X Memory Controller Hub ▪ Intel® ESB2-E I/O Controller
Onboard Connectors/Headers	<p>External connections:</p> <ul style="list-style-type: none"> ▪ Stacked PS/2* ports for keyboard and mouse ▪ DB9 serial port A connector ▪ Two RJ-45/2xUSB connectors for 10/100/1000 Mb and USB 2.0 support ▪ One USB 2x5 pin header, which supports two USB ports ▪ One USB port Type A connector ▪ One DH10 serial port B header ▪ Six SATA-2 connectors with integrated RAID 0, 1, and 10 support (order codes S5000XVNSATAR & BB5000XVNSATAR only) ▪ Software RAID 5 support through an optional SATA RAID KEY ▪ Two SATA-2 connectors and four SATA-2/SAS connectors with integrated RAID 0, 1, and 10 support (order codes S5000XVNSASR & BB5000XVNSASR only) ▪ Software RAID 5 support through an optional SAS RAID KEY (order codes S5000XVNSASR and BB5000XVNSASR only) ▪ Stacked audio connectors (audio in, audio out, microphone) ▪ One ATA100 40-pin connector ▪ SSI-compliant front panel header ▪ SSI-compliant 24-pin main power connector, supporting the ATX-12 V standard on the first 20 pins
Add-in PCI, PCI-X*, and PCI Express* Cards	<ul style="list-style-type: none"> ▪ One full-length/full-height PCI-X 64-bit slot with up to 100 MHz support ▪ One full-length/full-height PCI-X 64-bit slot with up to 133-MHz support when only one PCI-X slot is populated ▪ One full-length/full-height PCI Express* x4 (x4 throughput) - (x8 (x8 throughput) with order codes S5000XVNSATAR & BB5000XVNSATAR only) slot ▪ One half-length/full-height PCI Express* x4 (x4 Throughput) slot ▪ One full-length/full-height PCI Express* x16 (x16 throughput) slot
Audio	Realtec* ALC260 2-channel high-definition audio codec with universal audio architecture (24-bit, 2-channel DAC, two stereo 20-bit ADCs)
Hard Drive	<p>Support for six SATA-2 hard drives</p> <p>Support for four SAS hard drives (order codes S5000XVNSASR and BB5000XVNSASR only)</p>
LAN	Two 10/100/1000 Intel® 82563EB PHYs supporting Intel® I/O Acceleration Technology

Feature	Description
Fans	Support for <ul style="list-style-type: none">▪ Two processor fans▪ Four front hot-swap fans▪ Two rear system fans
Server Management	Support for Intel® System Management Software

2.2 Workstation Board Layout

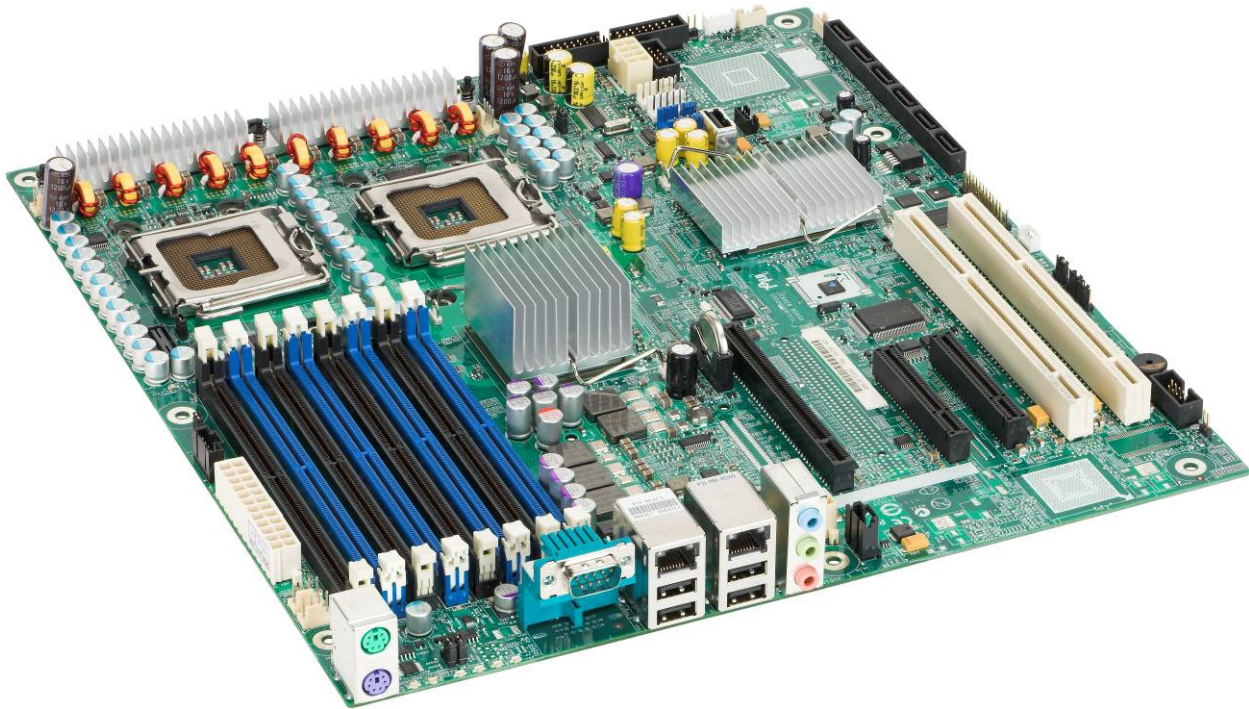
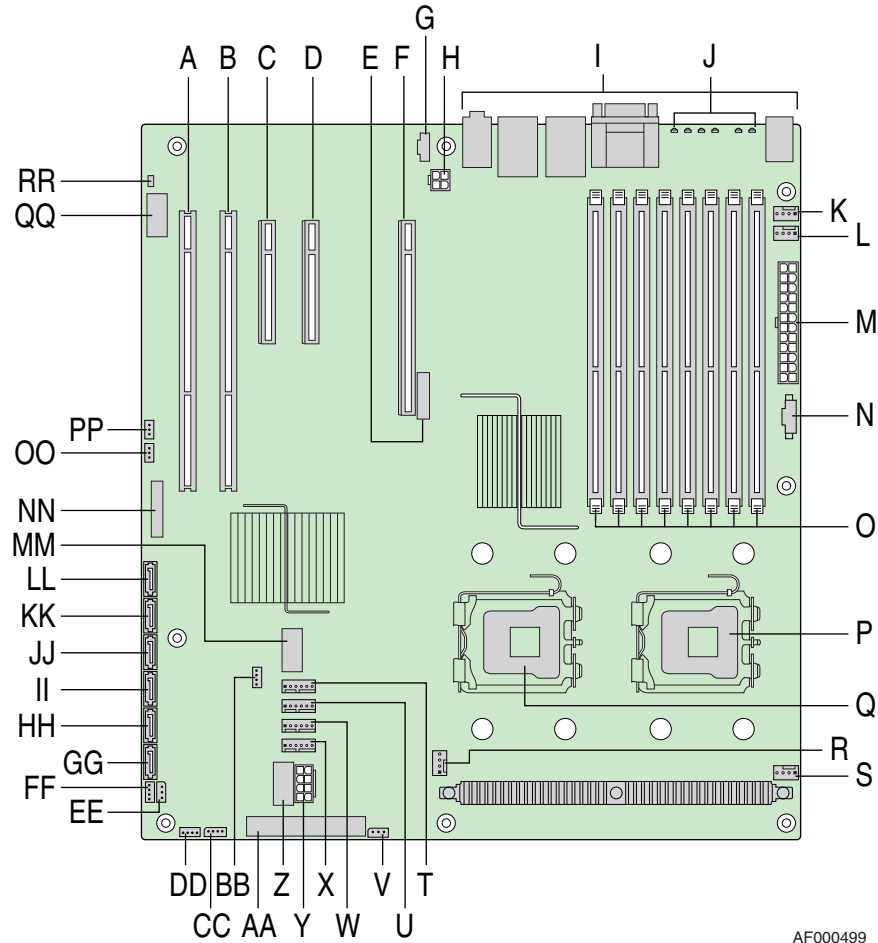

Figure 1. Workstation Board Photograph

2.2.1 Workstation Board Connector and Component Layout

The following figure shows the board layout of the workstation board. Each connector and major component is identified by a letter. A component descriptions table follows the figure.



AF000499

A. PCI-X* 64-bit, 100-MHz full-length/full-height slot 1	P. Processor 1 socket	EE. Enclosure management SAS SES I ² C (order code S5000XVNSASR only)
B. PCI-X 64-bit, 133-/100-MHz full-length/full-height slot 2	Q. Processor 2 socket	FF. Hot-swap backplane A header
C. PCI Express* x4 (S5000XVNSASR) or x8 (S5000XVNSATAR) full-length/full-height slot 3 (x8 connector)	R. Processor 2 fan header	GG. SATA 0
D. PCI Express* x4 half-length/full-height slot 4 (x8 connector)	S. Processor 1 fan header	HH. SATA 1
E. CMOS battery	T. System fan 4 header	II. SATA 2 or SAS 0 (SAS 0 on order code S5000XVNSASR only)
F. PCI Express x16 full-length/full-height slot 6 (x16 connector)	U. System fan 3 header	JJ. SATA 3 or SAS 1 (SAS 1 on order code S5000XVNSASR only)
G. CD-ROM line-in connector	V. IPMB connector	KK. SATA 4 or SAS 2 (SAS 2 on order code S5000XVNSASR only)

H. P12V4 connector	W. System fan 2 header	LL. SATA 5 or SAS 3 (SAS 3 on order code S5000XVNSASR only)
I. Back panel I/O ports	X. System fan 1 header	MM. USB port
J. Diagnostic and Identify LEDs	Y. Processor power connector	NN. Front control panel header
K. System fan 6 header	Z. USB header	OO. SATA software RAID 5 key connector
L. System fan 5 header	AA. IDE connector	PP. SAS software RAID 5 key connector (order code S5000XVNSASR only)
M. Main power connector	BB. Enclosure management SATA SGPIO header	QQ. Serial B/emergency management port header
N. Auxilliary power signal connector	CC. Hot-swap backplane B header	RR. Chassis intrusion header
O. DIMM sockets	DD. Enclosure management SAS SGPIO header (order code S5000XVNSASR only)	

Figure 2. Major Board Components

2.2.2 Workstation Board Mechanical Drawings

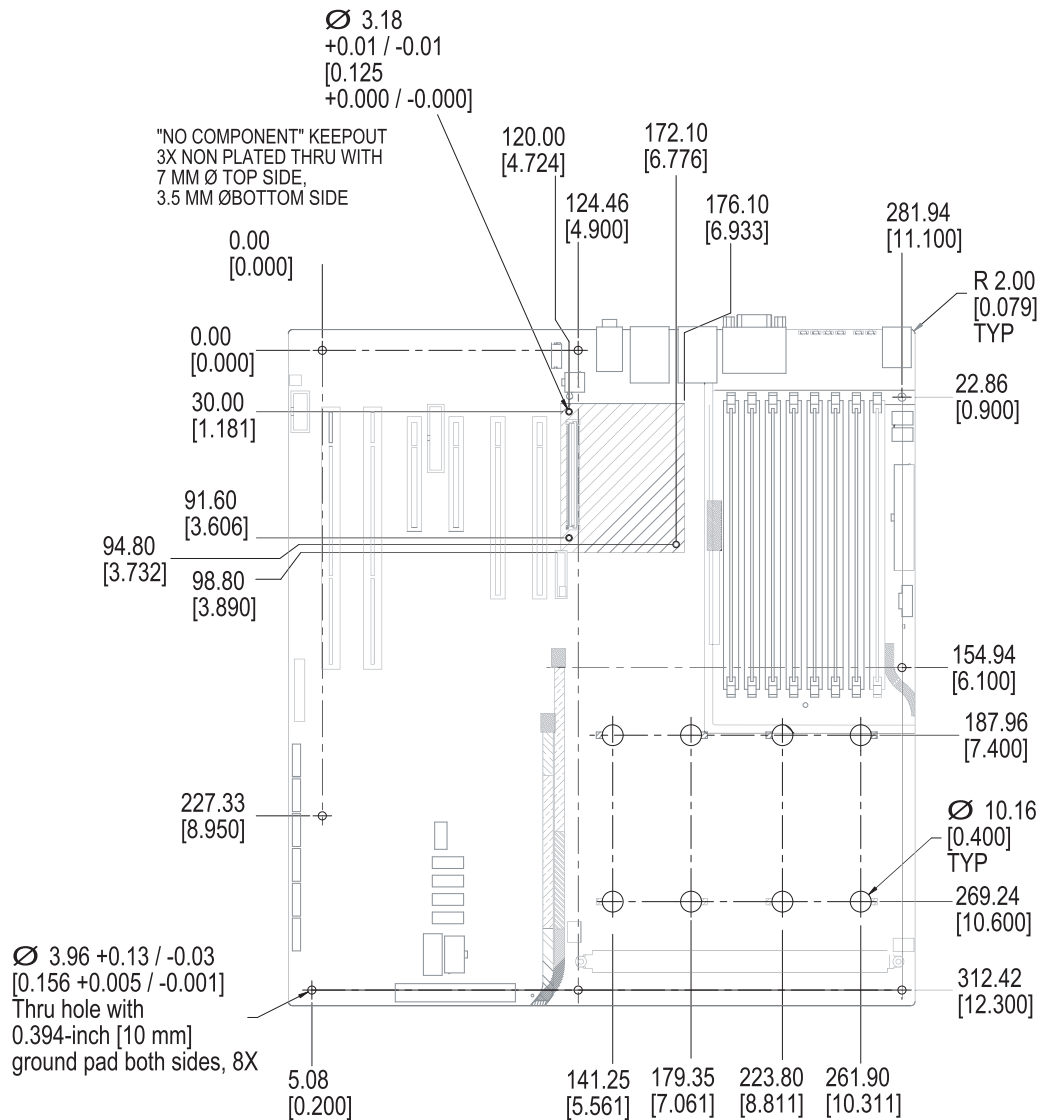
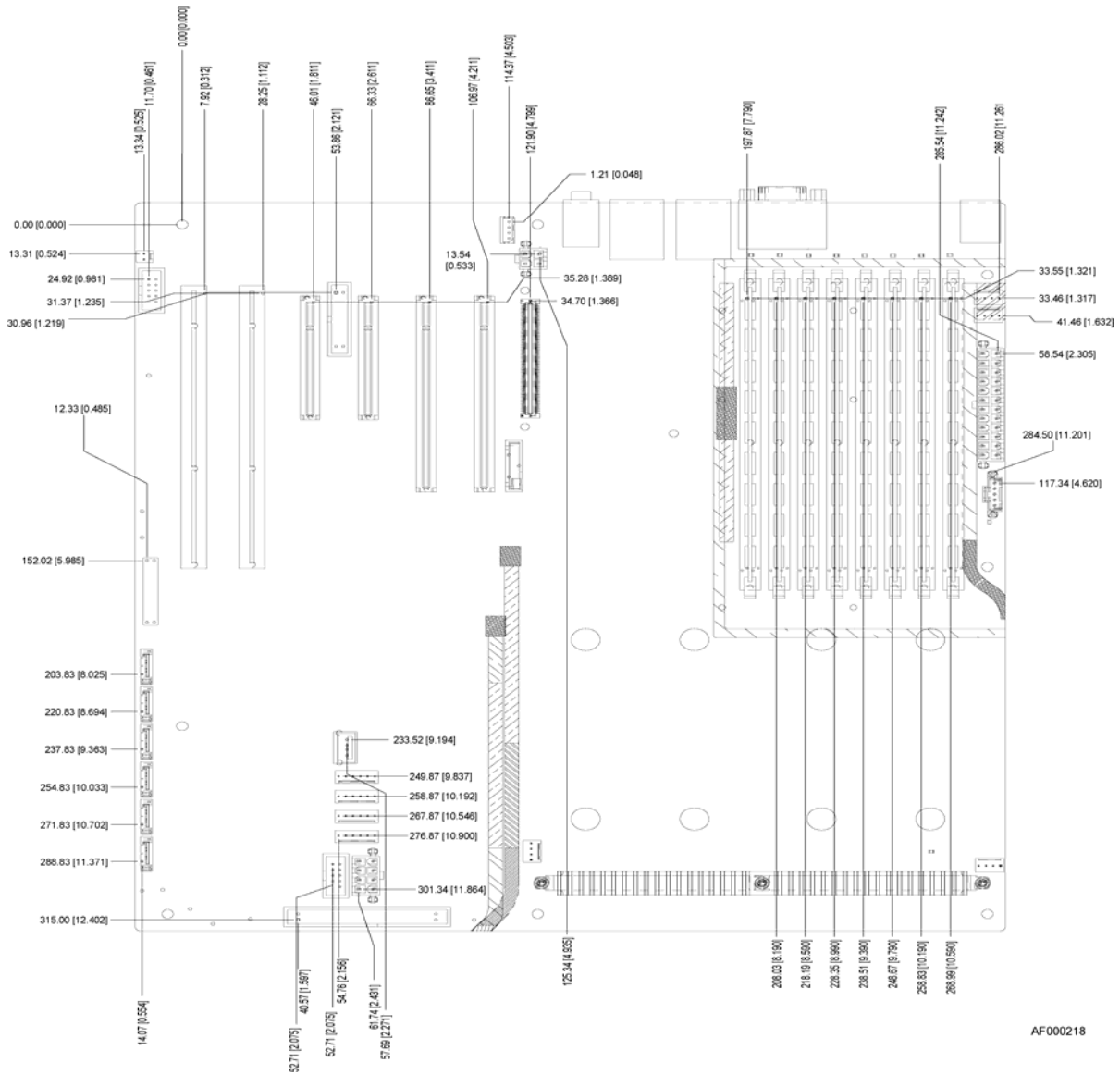

Figure 3. Mounting Hole Positions



AF000218

Figure 4. Component Positions

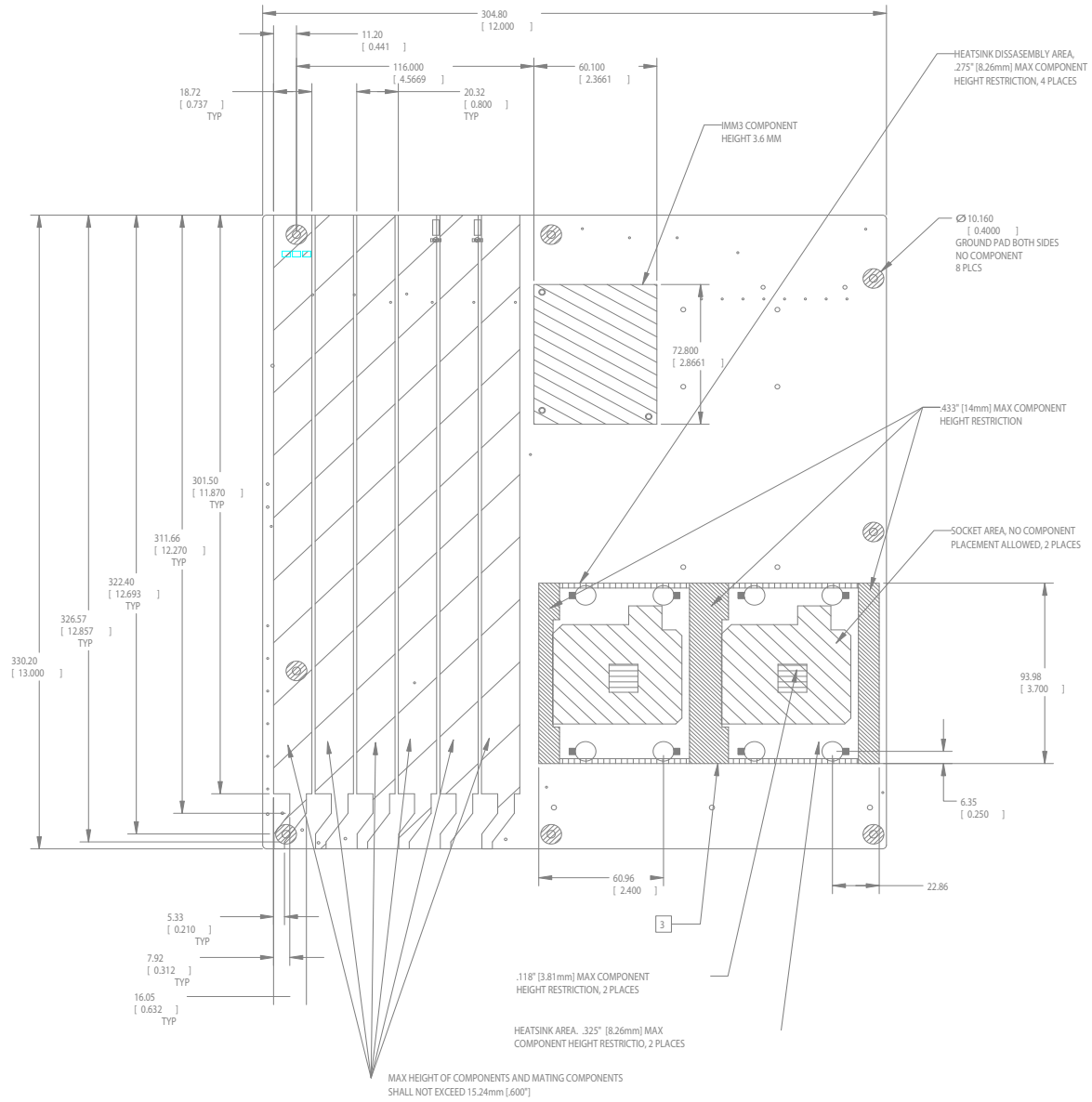

Figure 5. Restricted Areas on Side 1

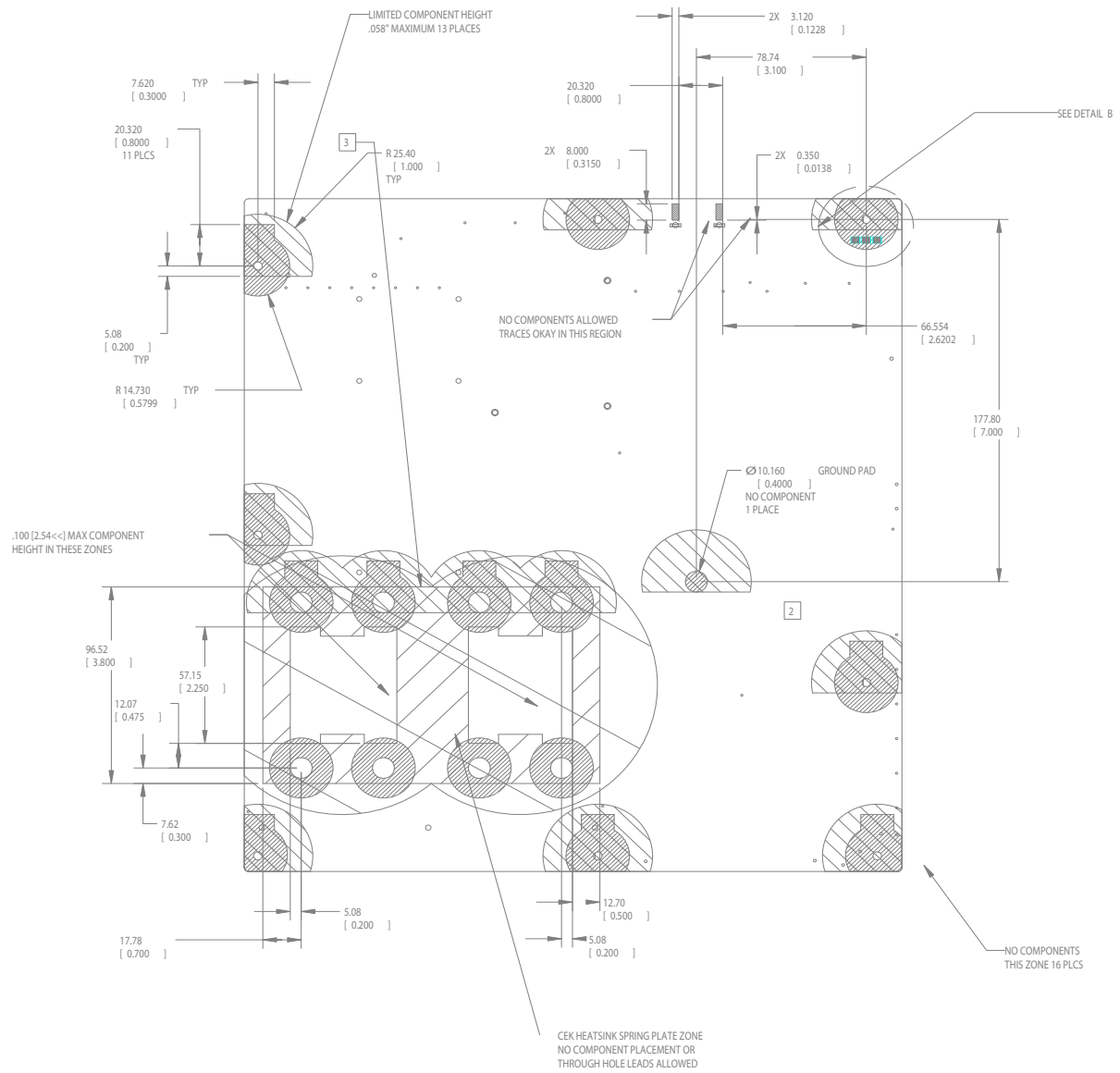

Figure 6. Restricted Areas on Side 2

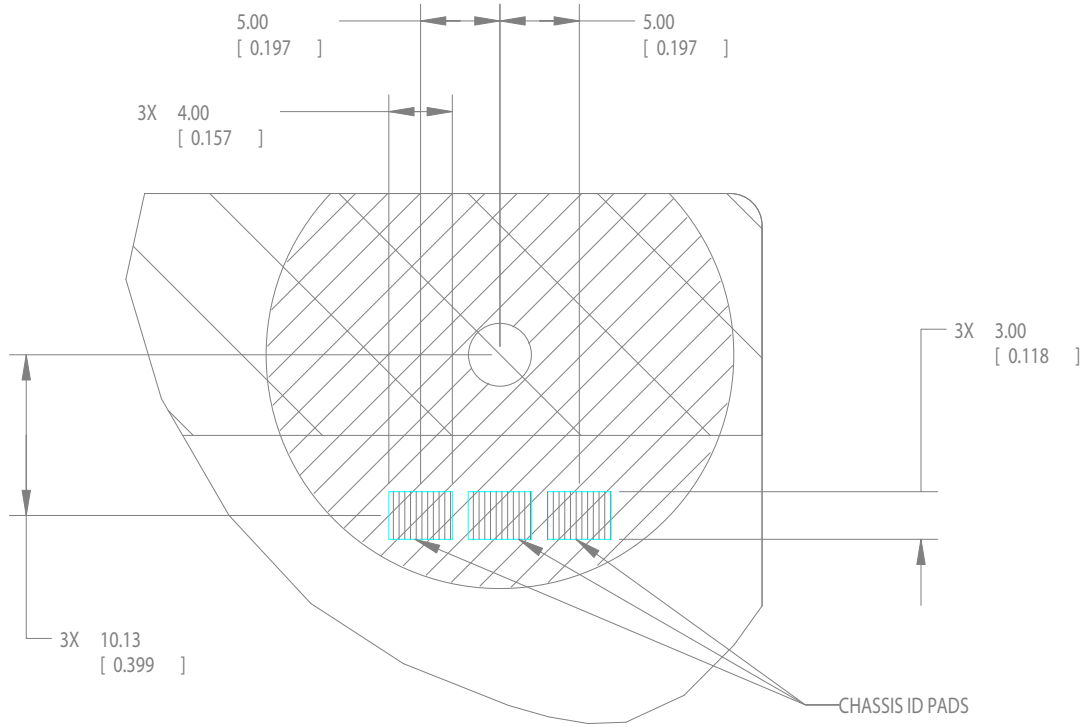

Figure 7. Restricted Areas on Side 2, “Detail B”

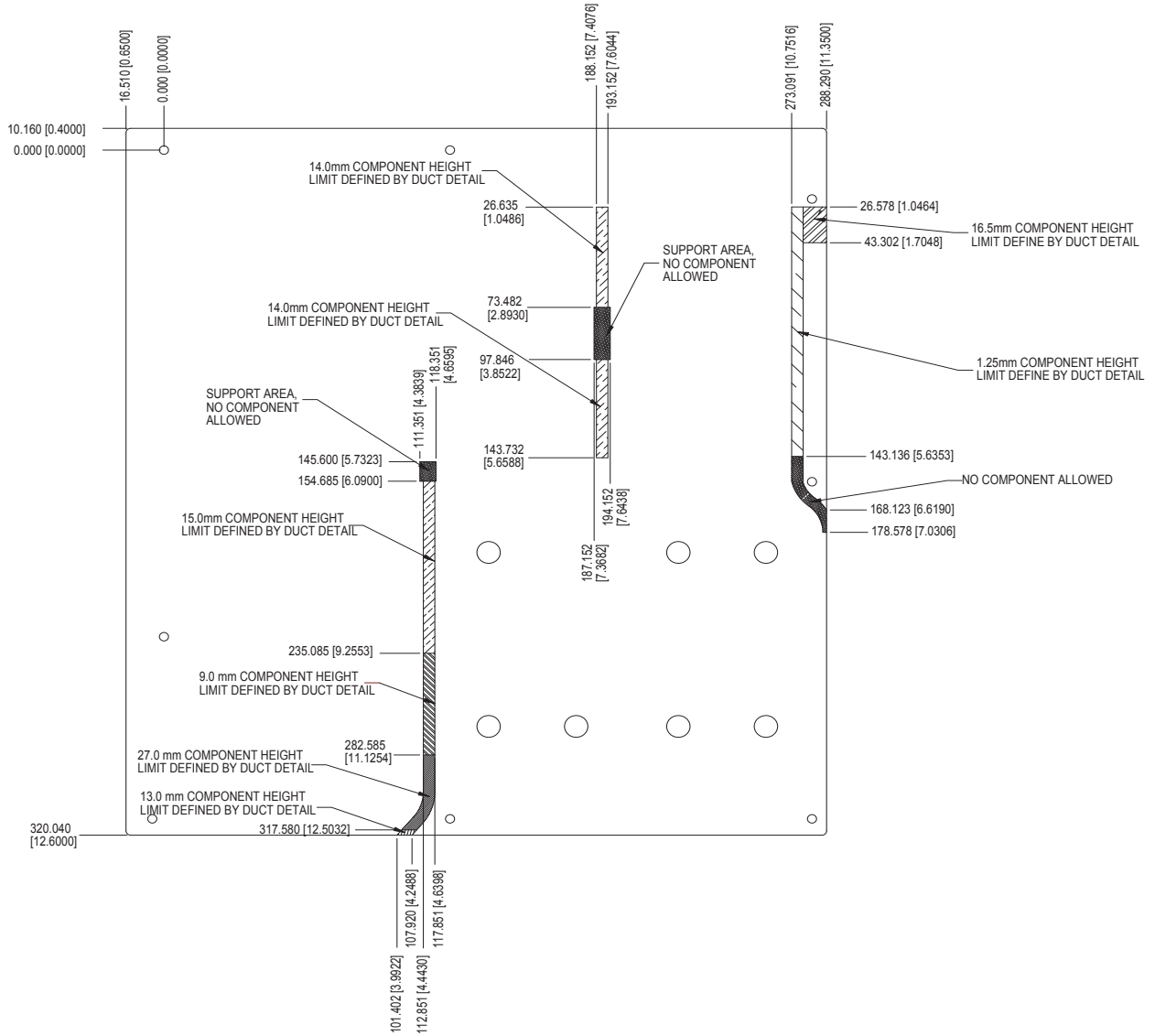
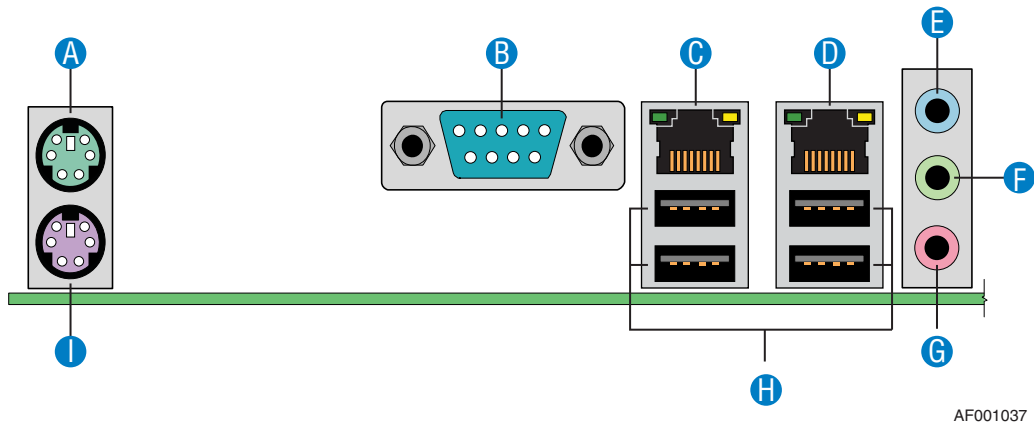

Figure 8. CPU and Memory Duct Keepout

2.2.3 Workstation Board ATX I/O Layout

The following drawing shows the layout of the rear I/O components for the workstation board:



AF001037

A. PS/2 mouse	F. Audio out
B. Serial A port	G. Microphone
C. NIC 1 (1 Gb)	H. ID LED
D. NIC 2	I. Keyboard port
E. Audio in	

Figure 9. ATX I/O Layout

3. Functional Architecture

The architecture and design of the Intel® Workstation Board S5000XVN is based on the Intel® S5000X chipset. This chipset is designed for systems that use the Intel® Xeon® processor with system bus speeds of 667 MHz, 1066 MHz, and 1333 MHz.

The chipset contains two main components: the Memory Controller Hub (MCH) for the host bridge and the I/O controller hub for the I/O subsystem. The chipset uses the Enterprise South Bridge (ESB2-E) for the I/O controller hub. This chapter provides a high-level description of the functionality associated with each chipset component and the architectural blocks that make up the server board.

For more information about the functional architecture blocks, see the *Intel® S5000 Server Board Family Datasheet*.

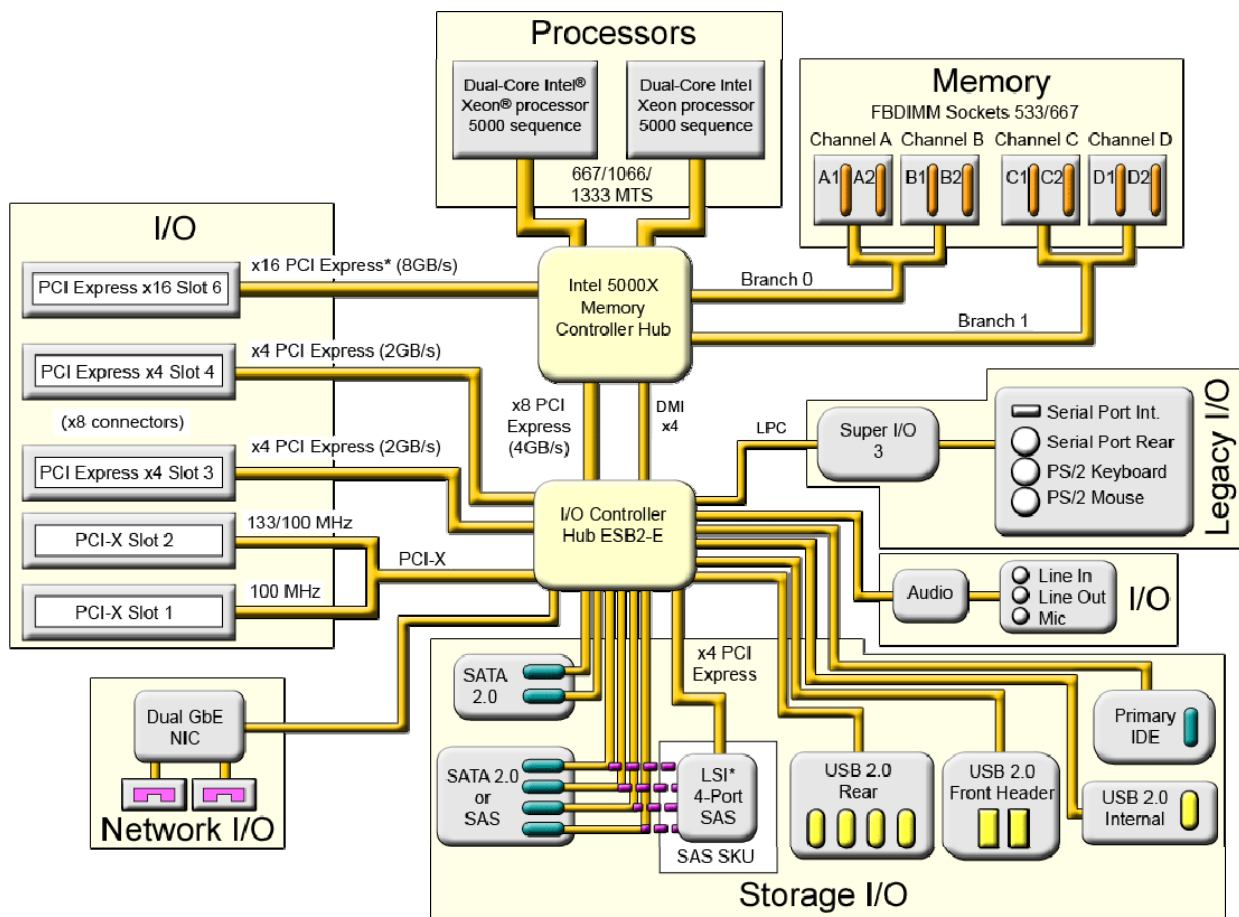

Figure 10. Functional Block Diagram

3.1 Intel® 5000X Memory Controller Hub (MCH)

The Memory Controller Hub (MCH) is a single 1432-pin FCBGA package, which includes the following core platform functions:

- System Bus Interface for the processor subsystem
- Memory Controller
- PCI-Express Ports including the Enterprise South Bridge Interface (ESI)
- FBD Thermal Management
- SMBUS Interface

This section provides a high-level overview of some of these core functions as they pertain to this workstation board. You can obtain additional information from the *Intel S5000 Server Board Family Datasheet* and the *Intel 5000 Series Chipset Memory Controller Hub Datasheet*.

3.1.1 System Bus Interface

The MCH is configured for symmetric multi-processing across two independent front side bus (FSB) interfaces that connect to the Intel® Xeon® processors. Each front side bus on the MCH uses a 64-bit wide 667, 1066, or 1333 MHz data bus. The 1333-MHz data bus is capable of transferring data at up to 10.66 GB/s. The MCH supports a 36-bit wide address bus, capable of addressing up to 64 GB of memory. The MCH is the priority agent for both front side bus interfaces, and is optimized for one processor on each bus.

3.1.2 Processor Support

The workstation board supports one or two Intel® Xeon® processors 5000 sequence with system bus speeds of 667 MHz, 1066 MHz, and 1333 MHz, and core frequencies starting at 2.66 GHz. This workstation board does not support previous generations of the Intel® Xeon® processor.

Note: Only Intel® Xeon® processors 5000 Sequence that support system bus speeds of 667 MHz, 1066 MHz, and 1333 MHz are supported on this workstation board. For a list of supported processors, refer to the following table.

Table 2. Processor Support Matrix

Processor Family	System Bus Speed	Core Frequency	Cache	Watts	Support
Intel® Xeon® Processor	533 MHz	All			No
Intel® Xeon® Processor	800 MHz	All			No
Intel® Xeon® Processor 5030	667 MHz	2.66	2 MB	95	Yes
Intel® Xeon® Processor 5050	667 MHz	3.0 GHz	2 MB	95	Yes
Intel® Xeon® Processor 5060	1066 MHz	3.2 GHz	2 MB	130	Yes
Intel® Xeon® Processor 5063	1066 MHz	3.2 GHz	2 MB	95	Yes
Intel® Xeon® Processor 5080	1066 MHz	3.73 GHz	2 MB	130	Yes
Intel® Xeon® Processor 5110	1066 MHz	1.60 GHz	4 MB	65	Yes
Intel® Xeon® Processor 5120	1066 MHz	1.86 GHz	4 MB	65	Yes
Intel® Xeon® Processor 5130	1333 MHz	2.00 GHz	4 MB	65	Yes
Intel® Xeon® Processor 5140	1333 MHz	2.33 GHz	4 MB	65	Yes

Processor Family	System Bus Speed	Core Frequency	Cache	Watts	Support
Intel® Xeon® Processor 5148	1333 MHz	2.33 GHz	4 MB	40	Yes
Intel® Xeon® Processor 5150	1333 MHz	2.66 GHz	4 MB	65	Yes
Intel® Xeon® Processor 5160	1333 MHz	3.00 GHz	4 MB	80	Yes
Intel® Xeon® Processor E5310	1333 MHz	1.6 GHz	8 MB	80	Yes
Intel® Xeon® Processor E5320	1333 MHz	1.86 GHz	8 MB	80	Yes
Intel® Xeon® Processor E5335	1333 MHz	2.00 GHz	8 MB	80	Yes
Intel® Xeon® Processor E5345	1333 MHz	2.33 GHz	8 MB	80	Yes
Intel® Xeon® Processor X5355	1333 MHz	2.66 GHz	8 MB	120	Yes

3.1.2.1 Processor Population Rules

When two processors are installed, both must be of identical revision, core voltage, and bus/core speed. When only one processor is installed, it must be in the socket labeled CPU1. The other socket must be empty.

The board is designed to provide up to 130 A of current per processor. This board does not support processors with higher current requirements.

No terminator is required in the second processor socket when using a single processor configuration.

3.1.2.2 Common Enabling Kit (CEK) Design Support

The workstation board complies with Intel's Common Enabling Kit (CEK) processor mounting and heatsink retention solution. The workstation board ships with a CEK spring snapped onto the underside of the workstation board beneath each processor socket. The heatsink attaches to the CEK over the top of the processor and the thermal interface material (TIM). Refer to the following figure for the stacking order of the chassis, CEK spring, workstation board, TIM, and heatsink.

The CEK spring is removable, which allows for the use of non-Intel heatsink retention solutions.

Note: The processor heatsink and CEK spring shown in the following diagram are for reference purposes only. The actual processor heatsink and CEK solutions compatible with this generation server board may be of a different design.

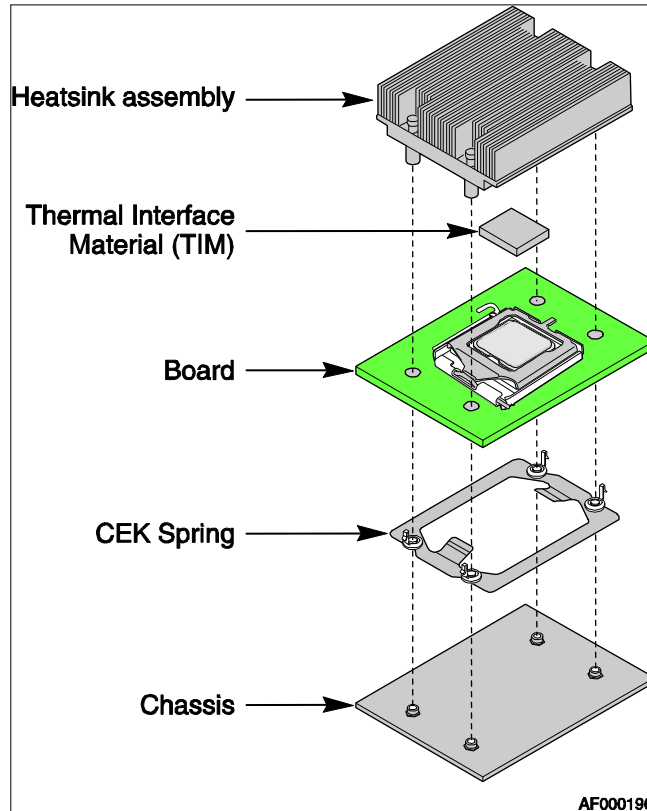
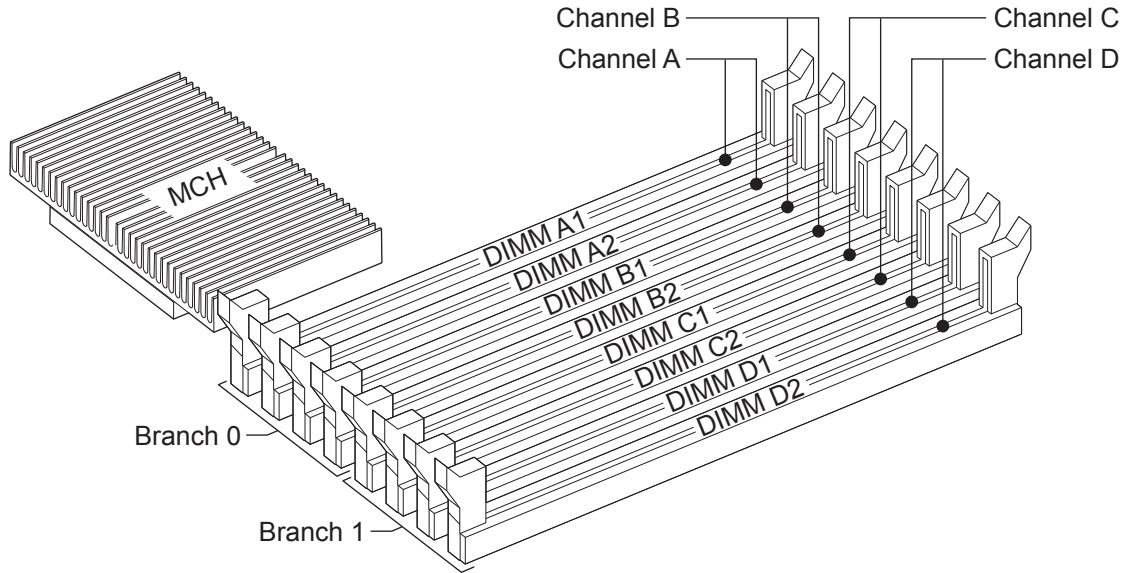

Figure 11. CEK Processor Mounting

3.1.3 Memory Subsystem

The MCH supports four fully buffered DIMM (FBD) memory channels. FBD memory uses a narrow, high-speed, frame-oriented interface referred to as a channel. The four FBD channels are organized into two branches of two channels per branch. Each branch is supported by a separate memory controller. The two channels on each branch operate in lock-step to increase FBD bandwidth. The four channels are routed to eight DIMM sockets and are capable of supporting registered DDR2-533 and DDR2-667 FBDIMM memory (stacked or unstacked). Peak theoretical memory data bandwidth is 6.4GB/s with DDR2-533 and 8.0GB/s with DDR2-667.

On the Intel® Workstation Board S5000XVN, a pair of channels becomes a branch where Branch 0 consists of channels A and B, and Branch 1 consists of channels C and D. FBD memory channels are organized into two branches for support of RAID 1 (mirroring).



TP02299

Figure 12. Memory Layout

To boot the system, the system BIOS on the workstation board uses a dedicated I²C bus to retrieve DIMM information needed to program the MCH memory registers. The following table provides the I²C addresses for each DIMM socket.

Table 3. I²C Addresses for Memory Module SMB

Device	Address
DIMM A1	0xA0
DIMM A2	0xA2
DIMM B1	0xA0
DIMM B2	0xA2
DIMM C1	0xA0
DIMM C2	0xA2
DIMM D1	0xA0
DIMM D2	0xA2

3.1.3.1 Memory RASUM Features

The MCH supports several memory RASUM (Reliability, Availability, Serviceability, Usability, and Manageability) features. These features include the Intel® x4 Single Device Data Correction (Intel® x4 SDDC) for the following:

- Memory error detection and correction
- Memory scrubbing
- Retry on correctable errors
- Memory built-in self-test
- DIMM sparing
- Memory mirroring

For more information about these features, refer to the *Intel® S5000 Server Board Family Datasheet*.

3.1.3.2 Supported Memory

The workstation board supports up to eight DDR2-533 or DDR2-667 fully-buffered DIMMs (FBD memory). The following tables show the maximum memory configurations supported with the specified memory technology.

Table 4. Maximum Eight-DIMM System Memory Configuration – x8 Single Rank

DRAM Technology x8 Single Rank	Maximum Capacity Mirrored Mode	Maximum Capacity Non-mirrored Mode
256 Mb	1 GB	2 GB
512 Mb	2 GB	4 GB
1024 Mb	4 GB	8 GB
2048 Mb	8 GB	16 GB

Table 5. Maximum Eight-DIMM System Memory Configuration – x4 Dual Rank

DRAM Technology x4 Dual Rank	Maximum Capacity Mirrored Mode	Maximum Capacity Non-mirrored Mode
256 Mb	4 GB	8 GB
512 Mb	8 GB	16 GB
1024 Mb	16 GB	32 GB
2048 Mb	16 GB	32 GB

Table 6. Maximum Eight-DIMM System Memory Configuration – x2 Quad Rank

DRAM Technology x2 Quad Rank	Maximum Capacity Mirrored Mode	Maximum Capacity Non-mirrored Mode
1024 Mb	16 GB	32 GB
2048 Mb	16 GB	32 GB

Note: This workstation board supports only fully buffered DDR2 DIMMs (FBDIMMs). See the Intel® Workstation Board S5000XVN Tested Memory List for a list of supported memory for this server board.

3.1.3.3 DIMM Population Rules and Supported DIMM Configurations

DIMM population rules depend on the operating mode of the memory controller, which is determined by the number of DIMMs installed. You must populate DIMMs in pairs. DIMM pairs are populated in the following DIMM socket order:

- A1 and B1
- C1 and D1
- A2 and B2
- C2 and D2

DIMMs within a given pair must be identical with respect to size, speed, and organization. However, DIMM capacities can be different between different DIMM pairs. For example, a valid mixed DIMM configuration may have 512 MB FBDIMMs installed in DIMM sockets A1 and B1, and 1 GB FBDIMMs installed in DIMM sockets C1 and D1.

In the following table, the following codes are used:

- VP: Validated configuration and the slot is populated
- SP: Supported, but not validated configuration, and the slot is populated
- NP: Slot is not populated

Table 7. DIMM Population Rules

Branch 0				Branch 1				Mirroring Possible	Sparing Possible
Channel A		Channel B		Channel C		Channel D			
DIMM_A1	DIMM_A2	DIMM_B1	DIMM_B2	DIMM_C1	DIMM_C2	DIMM_D1	DIMM_D2		
VP	NP	NP	NP	NP	NP	NP	NP	No	No
VP	NP	VP	NP	NP	NP	NP	NP	No	No
SP	SP	SP	SP	NP	NP	NP	NP	No	SP, Yes, Branch 0 only
VP	NP	VP	NP	VP	NP	VP	NP	VP, Yes	No
SP	SP	SP	SP	SP	NP	SP	NP	No	SP, Yes, Branch 0 only
VP	VP	VP	VP	VP	VP	VP	VP	VP, Yes	VP, Yes, Branch 0 and Branch 1

Notes:

- Single channel mode is only tested and supported with a 512 MB x8 FBDIMM installed in DIMM Socket A1.
- The supported memory configurations must meet population rules defined above.
- For best performance, you should install a minimum of four DIMMs across memory branches.
- Although mixed DIMM capacities between channels are supported, Intel® does not validate FBDIMMs in mixed DIMM configurations.

3.1.3.3.1 Minimum Non-Mirrored Mode Configuration

The workstation board is capable of supporting a minimum of one DIMM installed. However, for system performance reasons, Intel's recommendation is that at least two DIMMs are installed.

The following diagram shows the recommended minimum DIMM memory configuration. Populated DIMM slots are shown in gray.

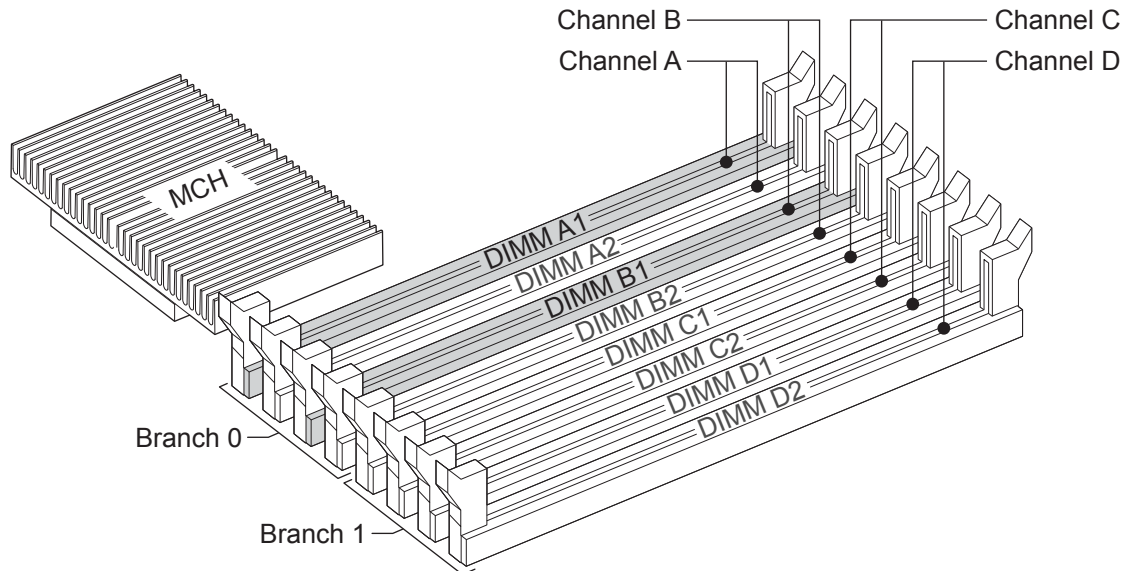

TP02300

Figure 13. Minimum 2-DIMM Memory Configuration

Note: The workstation board supports single DIMM mode operation. Intel will only validate and support this configuration with a single 512 MB x8 FBDIMM installed in DIMM socket A1.

3.1.3.4 Non-mirrored Mode Memory Upgrades

The minimum memory upgrade increment is two DIMMs per branch. The DIMMs must cover the same slot position on both channels. DIMMs pairs must be identical with respect to size, speed, and organization. DIMMs that cover adjacent slot positions do not need to be identical.

When adding two DIMMs to the configuration shown in Figure 13 (above), you should populate the DIMMs in DIMM sockets C1 and D1 as shown in the following diagram. Populated DIMM sockets are shown in gray.

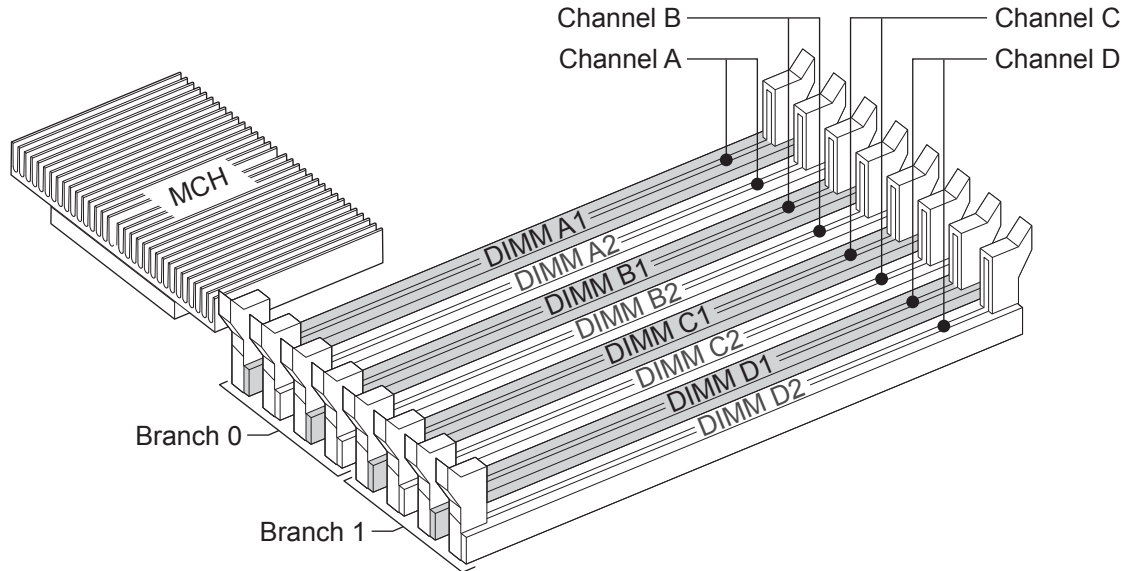

TP02301

Figure 14. Recommended Four DIMM Configuration

Functionally, DIMM sockets A2 and B2 could have been populated instead of DIMM sockets C1 and D1. However, the system would not achieve equivalent performance. Figure 13, on the previous page, shows the supported DIMM configuration that is recommended because it allows both branches to operate independently and simultaneously. FBD bandwidth is doubled when both branches operate in parallel.

3.1.3.4.1 Mirrored Mode Memory Configuration

When operating in mirrored mode, both branches operate in lock step. In mirrored mode, branch 1 contains a replicate copy of the data in branch 0. The minimum DIMM configuration to support memory mirroring is four DIMMs, populated as shown in Figure 14. All four DIMMs must be identical with respect to size, speed, and organization.

To upgrade a four DIMM mirrored memory configuration, you must add four additional DIMMs to the system. All four DIMMs in the second set must be identical to the first with the exception of speed. The MCH adjusts to the lowest speed DIMM.

3.1.3.4.2 Sparing Mode Memory Configuration

The MCH provides memory sparing capabilities. Sparing is a RAS feature that involves configuring a DIMM to be placed in reserve so it can be used to replace a DIMM that fails. DIMM sparing occurs within a given bank of memory and is not supported across branches. There are two supported memory sparing configurations.

- Single Branch Mode Sparing
- Dual Branch Mode Sparing

3.1.3.4.2.1 Single Branch Mode Sparing

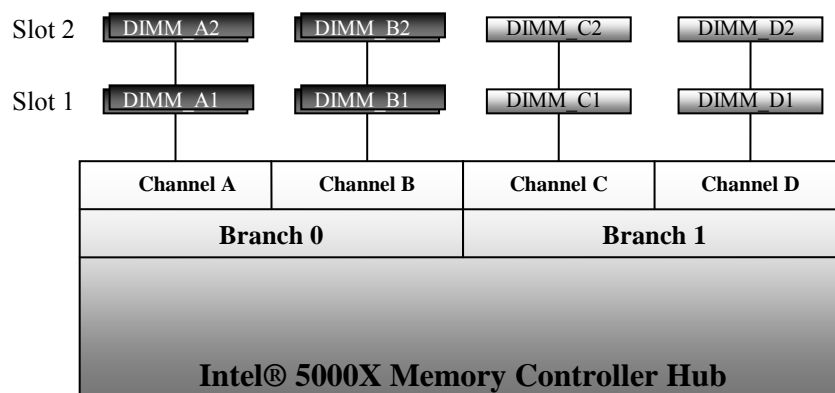

Figure 15. Single Branch Mode Sparing DIMM Configuration

- DIMM_A1 and DIMM_B1 must be identical in organization, size, and speed.
- DIMM_A2 and DIMM_B2 must be identical in organization, size, and speed.
- DIMM_A1 and DIMM_A2 need not be identical in organization, size, and speed.
- DIMM_B1 and DIMM_B2 need not be identical in organization, size, and speed.
- Sparing should be enabled in the BIOS setup.
- The BIOS will configure Rank Sparing Mode.
- The larger of the pairs {DIMM_A1, DIMM_B1} and {DIMM_A2, DIMM_B2} are selected as the spare pair unit.

3.1.3.4.2.2 Dual Branch Mode Sparing

Dual branch mode sparing requires that all eight DIMM sockets be populated and must comply with the following population rules.

- DIMM_A1 and DIMM_B1 must be identical in organization, size, and speed.
- DIMM_A2 and DIMM_B2 must be identical in organization, size, and speed.
- DIMM_C1 and DIMM_D1 must be identical in organization, size, and speed.
- DIMM_C2 and DIMM_D2 must be identical in organization, size, and speed.
- DIMM_A1 and DIMM_A2 need not be identical in organization, size, and speed.
- DIMM_B1 and DIMM_B2 need not be identical in organization, size, and speed.
- DIMM_C1 and DIMM_C2 need not be identical in organization, size, and speed.
- DIMM_D1 and DIMM_D2 need not be identical in organization, size, and speed.
- Sparing should be enabled in the BIOS setup.
- The BIOS will configure Rank Sparing Mode.
- The larger of the pairs {DIMM_A1, DIMM_B1}, {DIMM_A2, DIMM_B2}, {DIMM_C1, DIMM_D1}, and {DIMM_C2, DIMM_D2} are selected as the spare pair units.

3.1.4 Snoop Filter

The 5000X version of the MCH includes a snoop filter. Depending on the application of the workstation, you can use this feature to enhance the performance of the workstation by eliminating traffic on the snooped system bus of the processor being snooped. By removing snoops from the snooped bus, the full bandwidth is available for other transactions.

3.2 Enterprise South Bridge (ESB2-E)

The ESB2-E is a multi-function device that provides four distinct functions: an I/O controller, a PCI-X* bridge, GB Ethernet controller, and baseboard management controller (BMC). Each function has its own set of configuration registers. Once configured, each appears to the system as a distinct hardware controller.

The ESB2-E provides the gateway to all PC-compatible I/O devices and features. The workstation board uses the following ESB2-E features:

- PCI-X bus interface
- Six-channel SATA interface with SATA Busy LED Control
- Dual GbE MAC
- Baseboard Management Controller (BMC)
- Single ATA interface, with Ultra DMA 100 capability
- Universal Serial Bus 2.0 (USB) interface
- Removable media drives
- LPC bus interface
- PC-compatible timer/counter and DMA controllers
- APIC and 8259 interrupt controller
- Power management
- System RTC
- General purpose I/O

This section describes the function of most of the listed features as they pertain to this workstation board. For more detailed information, see the *Intel 631xESB/632xESB I/O Controller Hub Datasheet*.

3.2.1 PCI Subsystem

The primary I/O buses for the server board are PCI, PCI Express*, and PCI-X* with six independent PCI bus segments. The PCI buses comply with the *PCI Local Bus Specification*, Revision 2.3. The following table lists the characteristics of the PCI bus segments. Details about each bus segment follow the table.

Table 8. PCI Bus Segment Characteristics

PCI Bus Segment	Voltage	Width	Speed	Type	PCI I/O Card Slots
PCI32 ESB2-E	3.3 V	32 bit	33 MHz	PCI	None
PXA ESB2-E	3.3 V/5.0 V	64 bit	100 MHz	PCI-X*	PCI-X Slot 1
PXA ESB2-E	3.3 V/5.0 V	64 bit	133 MHz	PCI-X	PCI-X Slot 2
PE0 ESB2-E PCI Express* Port0	3.3 V	X4	10 Gb/S	PCI Express*	X4 throughput PCI Express* Slot 4
PE1 ESB2-E PCI Express* Port1	3.3 V	X4	10 Gb/S	PCI Express	x4 throughput PCI Express* Slot 3 (x8 throughput for workstation boards that do not support SAS by combining PE2 with PE1)
PE2 ESB2-E PCI Express* Port2	3.3 V	X4	10 Gb/S	PCI Express	x4 throughput to onboard SAS (re- routed to Slot 3 for workstation boards that do not support SAS)
PE4, PE5, PE6, PE7 BNB PCI Express* Ports 4, 5, 6, 7	3.3 V	X16	40 Gb/S	PCI Express	X16 throughput PCI Express* Slot 6

3.2.1.1 PCI32: 32-bit, 33-MHz PCI Subsystem

All 32-bit, 33-MHz PCI I/O is directed through the ESB2-E ICH6. The 32-bit, 33-MHz PCI segment created by the ESB2-E-ICH6 is known as the PCI32 segment. The PCI32 segment is not connected to any devices on the workstation board S5000XVN.

3.2.1.2 PXA: 64-bit, 133-MHz PCI Subsystem

One 64-bit PCI-X bus segment is directed through the ESB2-E ICH6. This PCI-X segment, PXA, is routed to PCI-X Slots 1 and 2. With only one PCI-X adapter populated in Slot 2 and Slot 1 left empty, PCI-X Slot 2 supports a maximum speed of 133MHz. With both Slot 1 and Slot 2 populated, Slot 2 supports a maximum speed of 100 MHz. PCI-X Slot 1 supports a maximum speed of 100 MHz even when Slot 2 is not populated.

3.2.1.3 PE0: One x4 PCI Express* Bus Segment

One x4 PCI Express* bus segment is directed through the ESB2-E. This PCI Express* segment, PE0, is routed to PCI Express* Slot 4.

3.2.1.4 PE1: One x4 PCI Express* Bus Segment

One x4 PCI Express* bus segment is directed through the ESB2-E. This PCI Express* segment, PE1, is routed to PCI Express* Slot 3. This becomes a x8 PCI Express* bus segment for workstation boards that do not support SAS by combining PE2 with PE1.

3.2.1.5 PE2: One x4 PCI Express* Bus Segment

One x4 PCI Express* bus segment is directed through the ESB2-E. This PCI Express* segment, PE2, is routed to PCI Express* Slot 3 for workstation boards that do not support SAS, or to the onboard SAS controller for workstation boards that do support SAS.

3.2.1.6 PE4, PE5, PE6, PE7: Four x4 PCI Express* Bus Segments

Four x4 PCI Express* bus segments are directed through the MCH. These PCI Express* segments, PE4, PE5, PE6 and PE7, are routed to PCI Express* Slot 6, making it a x16 slot.

3.2.1.7 PCI Express* Riser Slot

PCI Express* Slot 6 supports third-party riser cards for both 1U and 2U system configurations. Two PCI Express* pins are designated as riser type pins with the definitions noted in the following table:

Slot 6 Setup ¹	LP Riser Type 1		LP Riser Type 0	
	GPI:	ESB2 GPI 28	GPI:	ESB2 GPI 27
	PCI-E Pin:	B48 [RSVD]	PCI-E Pin:	B49 [GND]
2U Riser, 2 x8 PCI Express* Slots ²	0		1	
1U Riser, 1 x16 PCI Express* Slot ³	1		0	

Notes:

1. The workstation board contains a weak pull-up resistor on the two Riser Type nets.
2. The 2U riser card needs to pull-down the PCI Express* pin B48 with a 0 ohm resistor and leave as a No-Connect (NC) PCI Express* pin B49.
3. The 1U riser card needs to follow the standard PCI Express* Adapter pin-out by leaving pin B48 as a No-Connect (NC) and pin B49 as ground.

The following table provides the supported bus throughput for the given riser card used and the number of add-in cards installed.

PCI Express* Slot 6 Riser Support	One Add-in Card	Two Add-in Cards
1U Riser Card	X16	NA
2U Riser Card	X8	X8

Note: There are no population rules for installing a single add-in card in the 2U riser card; you can install a single ad- in card in either PCI Express* slot.

3.2.2 Serial ATA Support

The ESB2-E has an integrated Serial ATA (SATA) controller that supports independent DMA operation on six ports and supports data transfer rates of up to 3.0 Gb/s. The six SATA ports on the server board are numbered SATA-0 through SATA-5. You can enable/disable and/or configure the SATA ports by accessing the BIOS Setup utility during POST.

3.2.2.1 Intel® Embedded Server RAID Technology II Support

The onboard storage capability of this workstation board includes support for Intel® Embedded Server RAID Technology II, which provides three standard software RAID levels: data stripping (RAID Level 0), data mirroring (RAID Level 1), and data stripping with mirroring (RAID Level 10).

For higher performance, you can use data stripping to alleviate disk bottlenecks by taking advantage of the dual independent DMA engines that each SATA port offers. Data mirroring is used for data security. If a disk fails, a mirrored copy of the failed disk is brought on-line. There is no loss of either PCI resources (request/grant pair) or add-in card slots.

With the addition of an optional Intel® RAID Activation Key, Intel® Embedded Server RAID Technology II is also capable of providing fault tolerant data stripping (software RAID Level 5), such that if a SATA hard drive fails, you can restore the lost data on a replacement drive from the other drives that make up the RAID 5 pack.

See Figure 2 for the location of Intel® RAID Activation Key connector location.

Intel® Embedded Server RAID Technology functionality requires the following items:

- Intel® ESB-2 I/O Controller Hub
- Intel® Embedded Server RAID Technology Option ROM
- Intel® Application Accelerator RAID Edition drivers, most recent revision
- At least two SATA hard disk drives

Intel® Embedded Server RAID Technology is not available in the following configurations:

- The SATA controller in compatible mode
- Intel® Embedded Server RAID Technology has been disabled

3.2.2.2 Intel® Embedded Server RAID Technology Option ROM

The Intel® Embedded Server RAID Technology for SATA Option ROM provides a pre-operating system user interface for the Intel® Embedded Server RAID Technology implementation and provides the ability for an Intel® Embedded Server RAID Technology volume to be used as a boot disk and detect any faults in the Intel® Embedded Server RAID Technology volume(s) attached to the Intel® RAID controller.

3.2.3 Parallel ATA (PATA) Support

The integrated IDE controller of the ESB2-E ICH6 provides one IDE channel. It redefines signals on the IDE cable to allow both host and target throttling of data and transfer rates of up to 100 MB/s. For this workstation board, the IDE channel was designed to provide optical drive support to the platform. The BIOS initializes and supports ATAPI devices such as LS-120/240, CD-ROM, CD-RW, and DVD-ROM. The IDE channel is accessed through a single standard 40-pin IDE connector (J2J2) that provides the I/O signals. You can configure and enable/disable the ATA channel by accessing the BIOS Setup utility during POST.

3.2.4 USB 2.0 Support

The USB controller functionality integrated into ESB2-E provides the workstation board with the interface for up to seven USB 2.0 ports. Four external connectors are located on the back edge of the workstation board. One internal 2x5 header (J3J1) is provided, capable of supporting two optional USB 2.0 ports. One USB port Type A connector (J3G1) is provided to support installation of a USB device inside the server chassis.

3.3 Audio Codec

The workstation board supports the Intel® High Definition audio subsystem based on the Realtek* ALC260 audio codec. The ALC260 is a 2-channel HD Audio codec featuring a 24-bit, 2-channel DAC and two stereo 20-bit ADCs.

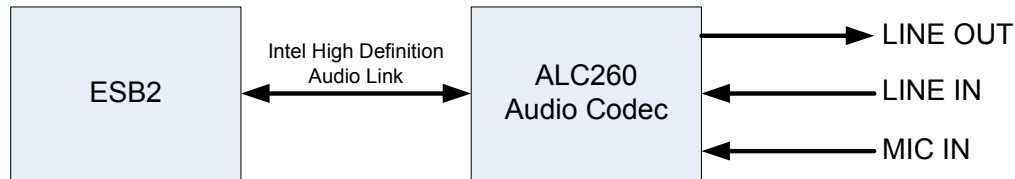

Figure 16. Audio Subsystem Block Diagram

The ALC260 provides two output channels with flexible mixing, mute, and fine gain controls to provide a complete integrated audio solution. The ALC260 provides high-quality audio using S/PDIF to output analog data or multiple-source recording applications. Jack-sensing allows inputs and output device loads to be auto-detected. Analog IOs are both input and output capable. The ALC260 supports 32-bit S/PDIF input/ output functions.

The feature list for the ALC260 is as follows:

- Single-chip multi-bit Sigma-Delta converters with high S/N ratio
- One stereo DAC that supports 16/20/24-bit PCM format with 44.1K/48K/96K/ 192kHz sample rate
- Two stereo ADCs that support 16/20-bit PCM format with 44.1K/48K/96kHz sample rate
- High-quality differential CD analog input
- -64dB ~ +30dB with 1dB mixer gain for fine volume control
- Impedance-sensing capability for each re-tasking jack
- Built-in headphone amplifier for each re-tasking jack
- Meets Microsoft WHQL/WLP 2.0* audio requirements
- Emulation of 26 sound environments to enhance the gaming experience
- 10-band software equalizer
- Enhanced configuration panel and device sensing wizard to improve user experience
- Mono/stereo microphone noise suppression

The workstation board supports the following audio connections through the rear I/O:

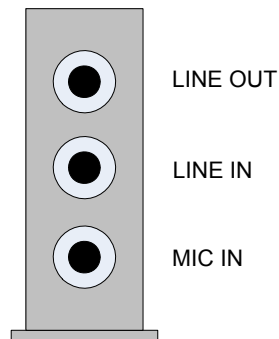

Figure 17. Rear I/O Panel Audio Connector

The workstation board supports ATAPI CD-ROM (a 1x4-pin ATAPI-style connector for connecting an internal ATAPI CD-ROM drive to the audio mixer, connector J4A1) audio connection inside the chassis.

3.4 SAS Controller

The LSI Logic* SAS1064e controller supports x4 PCI Express* link widths and is a single-function PCI Express* end-point device. The SAS controller supports the SAS protocol as described in the Serial Attached SCSI Standard, version 1.0. The controller also supports SAS 1.1 features.

The SAS1064e controller supports a 32-bit external memory bus that provides an interface for Flash ROM and NVSRAM devices.

3.4.1 SAS RAID Support

RAID modes 0, 1, and 10 are supported. You can use an optional SAS RAID Key to support SW RAID 5.

3.4.2 SAS/SATA Connector Sharing

Four SATA connectors are shared between SATA and SAS, depending on the version of the workstation board. For SAS workstation boards, four of the six SATA connectors are used for SAS functionality. For SATA workstation boards, all six SATA connectors are used for SATA functionality.

3.5 Network Interface Controller (NIC)

Network interface support is provided from the built in Dual GbE MAC features of the ESB2 in conjunction with the Intel® 82563EB compact Physical Layer Transceiver (PHY). Together, they provide the workstation board with support for dual LAN ports designed for 10/100/1000 Mbps operation.

The 82563EB device is based upon proven PHY technology integrated into Intel's gigabit Ethernet controllers. The physical layer circuitry provides a standard IEEE 802.3 Ethernet interface for 1000BASE-T, 100BASE-TX, and 10BASE-T applications (802.3, 802.3u, and 802.3ab). The 82563EB device is capable of transmitting and receiving data at rates of 1000 Mbps, 100 Mbps, or 10 Mbps.

Each network interface controller (NIC) drives two LEDs located on each network interface connector. The link/activity LED (at the left of the connector) indicates network connection when on and transmit/receive activity when blinking. The speed LED (at the right of the connector) indicates 1000-Mbps operation when amber; 100-Mbps operation when green; and 10-Mbps when off. The following table provides an overview of the LEDs.

Table 9. NIC2 Status LED

LED Color	LED State	NIC State
Green/Amber (Right)	Off	10 Mbps
	Green	100 Mbps
	Amber	1000 Mbps
Green (Left)	On	Active Connection
	Blinking	Transmit/Receive activity

3.5.1 Intel® I/O Acceleration Technology (Intel® I/OAT)

Intel® I/O Acceleration Technology (Intel® I/OAT) moves network data more efficiently through Intel® Xeon® processor 5000 sequence-based servers for improved application responsiveness across diverse operating systems and virtualized environments. Intel I/OAT improves network application responsiveness by using the power of Intel® Xeon® processors 5000 sequence using more efficient network data movement and reduced system overhead.

Intel multi-port network adapters with Intel® I/OAT provide high-performance I/O for server consolidation and virtualization via stateless network acceleration that seamlessly scales across multiple ports and virtual machines. Intel I/OAT provides safe and flexible network acceleration through tight integration into popular operating systems and virtual machine monitors, avoiding the support risks of third-party network stacks and preserving existing network requirements, such as teaming and failover.

3.5.2 MAC Address Definition

Each Intel® Workstation Board S5000XVN has four MAC addresses assigned to it at the Intel factory. During the manufacturing process, each workstation board will have a white MAC address sticker placed on the board. The sticker displays the MAC address in both bar code and alphanumeric formats. The printed MAC address is assigned to NIC 1 on the workstation board. NIC 2 is assigned the NIC 1 MAC address + 1.

Two additional MAC addresses are assigned to the baseboard management controller (BMC) that is embedded in the ESB-2. These MAC addresses are used by the BMC's embedded network stack to enable IPMI remote management over LAN. BMC LAN Channel 1 is assigned the NIC1 MAC address + 2, and BMC LAN Channel 2 is assigned the NIC1 MAC address + 3

3.6 Super I/O

Legacy I/O support is provided by using a National Semiconductor* PC87427 Super I/O device. This chip contains all of the necessary circuitry to support the following functions:

- GPIOs
- Two serial ports
- Keyboard and mouse support
- Wake up control
- System health support

3.6.1 Serial Ports

The workstation board provides two serial ports: an external DB9 serial port and an internal DH10 serial header. The rear DB9 serial A port is a fully-functional serial port that can support any standard serial device.

Serial B is an optional port that is accessed through a 9-pin internal DH-10 header. A standard DH10 to DB9 cable can be used to direct serial B to the rear of a chassis. The serial B interface follows the standard RS232 pin-out as defined in the following table.

Table 10. Serial B Header Pin-out

Pin	Signal Name	Serial Port B Header Pin-out
1	DCD	
2	DSR	
3	RX	
4	RTS	
5	TX	
6	CTS	
7	DTR	
8	RI	
9	GND	

3.6.2 Floppy Disk Controller

The workstation board does not support a floppy disk controller interface. However, the system BIOS recognizes USB floppy devices.

3.6.3 Keyboard and Mouse Support

Dual-stacked PS/2* ports are provided on the back edge of the workstation board for keyboard and mouse support. Either port can support a mouse or keyboard. Neither port supports hot plugging.

3.6.4 Wake-up Control

The super I/O contains functionality that allows various events to power on and power off the system.

3.6.5 System Health Support

The super I/O provides an interface via GPIOs for BIOS and system management firmware to activate the diagnostic LEDs, the FRU fault indicator LEDs for processors, FBDIMMS, fans, and the system status LED. See section 7 for the location of the LEDs on the workstation board.

The super I/O provides PWM fan control to the system fans, monitors tach and presence signals for the system fans, and monitors server board and front panel temperature.

3.6.6 Trusted Platform Module (TPM)

The TPM 1.2 component is specifically designed to enhance platform security above and beyond the capabilities of today's software by providing a protected space for key operations and other security critical tasks. Using both hardware and software, the TPM protects encryption and signature keys at their most vulnerable stages — operations when the keys are being used unencrypted in plain-text form. The TPM is specifically designed to shield unencrypted keys and platform authentication information from software-based attacks.

4. Platform Management

The platform management subsystem is based on the integrated Baseboard Management Controller features of the ESB2-E. The onboard platform management subsystem consists of communication buses, sensors, system BIOS, and server management firmware. The following diagram provides an overview of the Server Management Bus (SMBUS) architecture used on this workstation board.

See Appendix B for onboard sensor data.

For more detailed platform management information, see the *Intel® S5000 Server Board Family Datasheet*.

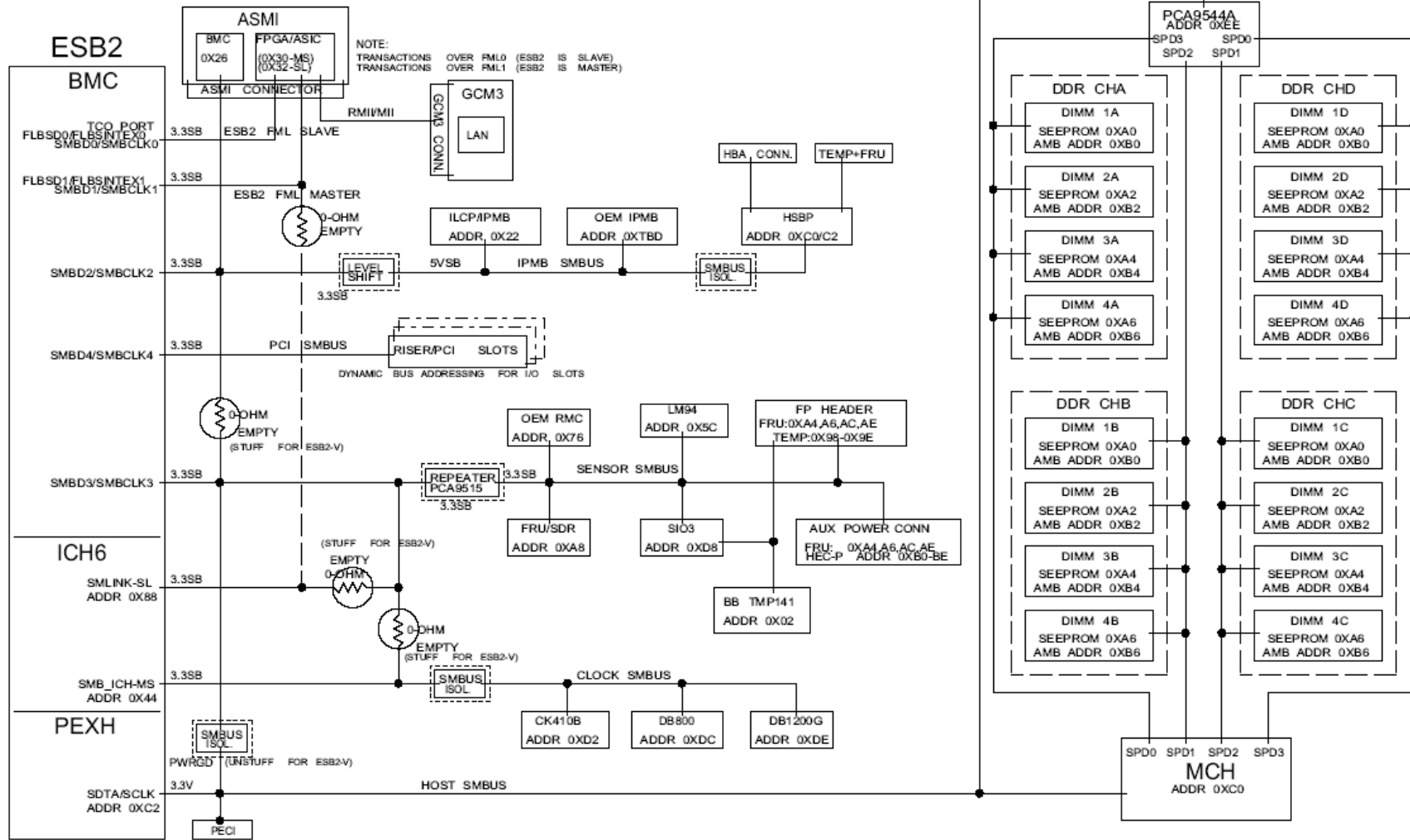

Figure 18. SMBUS Block Diagram

5. Connector/Header Locations and Pin-outs

5.1 Board Connector Information

The following section provides detailed information regarding all connectors, headers and jumpers on the workstation board. The following table lists all connector types available on the board and the corresponding reference designators printed on the silkscreen:

Table 11. Board Connector Matrix

Connector	Quantity	Reference Designators	Connector Type	Pin Count
Power supply	4	J9B5 J3J2 J9D1 J5A2	Main power CPU power P/S aux/IPMB P12V4 power	24 8 5 4
CPU	2	J8G1, J5G1	CPU sockets	771
Main memory	8	J7B1, J7B2, J7B3, J8B1, J8B2, J8B3, J9B1, J9B2	DIMM sockets	240
PCI-X	2	J1B2, J2B1	Card edge	
PCI Express* x8	2	J2B2, J3B1	Card edge	
PCI Express* x16	1	J4B2	Card edge	
RAID Key	2	J1E1, J1D3	Key holder	3
IDE	1	J2J2	Shrouded header	40
System fans	4	J3H1, J3H2, J3H3, J3H4	Header	6
System fans	2	J9B3, J9B4	Header	4
CPU fans	2	J9J1, J5J1	Header	4
Battery	1	XBT4D1	Battery holder	3
Keyboard/mouse	1	J9A1	PS2, stacked	12
Stacked RJ45/2xUSB	2	JA6A1, JA6A2	External LAN built-in magnetic and dual USB	22
Audio	2	J5A1 J4A1	Audio, stacked CD In	3 jacks 4
Serial port A	1	J7A1	External DB9	9
Serial port B	1	J1B1	Header	10
Front panel	1	J1E4	Header	24
Internal USB	1	J3J1	Header	10
Internal USB	1	J3G1	Type A connector	4
Chassis Intrusion	1	J1A1	Header	2
Serial ATA/SAS	6	J1G1, J1F2, J1H1, J1G2, J1J1, J1H2	Header	7
HSBP/SGPIO	4	J1J2, J1J7, J2H1, J1J5	Header	4
SES I2C	1	J1J3	Header	3
LCP/AUX IPMB	1	J2J1	Header	4
IPMB	1	J4J1	Header	3
HDD Activity	1	J2J3	Header	2

Connector	Quantity	Reference Designators	Connector Type	Pin Count
Configuration jumpers	4	J1D2 (Password Clear), J1D1 (CMOS Clear), J1C3 (BIOS Bank Select), J1E3 (BMC Force Update)	Jumper	3

5.2 Power Connectors

The main power supply connection uses an SSI-compliant 2x12 pin connector (J9B5). In addition, there are three additional power related connectors:

- One SSI-compliant 2x4 pin power connector (J3J2) provides 12V power to the CPU Voltage Regulators
- One SSI-compliant 1x5 pin connector (J9D1) provides I²C monitoring of the power supply
- One SSI-compliant 2x2 pin connector (J5A2) provides additional 12V power to the server board

The following tables define the connector pin-outs.

Table 12. Power Connector Pin-out (J9B5)

Pin	Signal	Color	Pin	Signal	Color
1	+3.3 Vdc	Orange	13	+3.3 Vdc	Orange
2	+3.3 Vdc	Orange	14	-12 Vdc	Blue
3	GND	Black	15	GND	Black
4	+5 Vdc	Red	16	PS_ON#	Green
5	GND	Black	17	GND	Black
6	+5 Vdc	Red	18	GND	Black
7	GND	Black	19	GND	Black
8	PWR_OK	Gray	20	RSVD_(-5 V)	White
9	5 VSB	Purple	21	+5 Vdc	Red
10	+12 Vdc	Yellow	22	+5 Vdc	Red
11	+12 Vdc	Yellow	23	+5 Vdc	Red
12	+3.3 Vdc	Orange	24	GND	Black

Table 13. 12-V Power Connector Pin-out (J3J2)

Pin	Signal	Color
1	GND	Black
2	GND	Black
3	GND	Black
4	GND	Black
5	+12 Vdc	Yellow/black
6	+12 Vdc	Yellow/black
7	+12 Vdc	Yellow/black
8	+12 Vdc	Yellow/black

Table 14. Power Supply Signal Connector Pin-out (J9D1)

Pin	Signal	Color
1	SMB_CLK_ESB_FP_PWR_R	Orange
2	SMB_DAT_ESB_FP_PWR_R	Black
3	SMB_ALERT_3_ESB_R	Red
4	3.3 V SENSE-	Yellow
5	3.3 V SENSE+	Green

Table 15. P12V4 Power Connector Pin-out (J5A2)

Pin	Signal	Color
1	GND	Black
2	GND	Black
3	+12 Vdc	Yellow/black
4	+12 Vdc	Yellow/black

5.3 System Management Headers

5.3.1 LCP/AUX IPMB Header

Table 16. LCP/AUX IPMB Header Pin-out (J2J1)

Pin	Signal Name	Description
1	SMB_IPMB_5VSB_DAT	BMC IMB 5V standby data line
2	GND	Ground
3	SMB_IPMB_5VSB_CLK	BMC IMB 5V standby clock line
4	P5V_STBY	+5 V standby power

5.3.2 IPMB Header

Table 17. IPMB Header Pin-out (J4J1)

Pin	Signal Name	Description
1	SMB_IPMB_5VSB_DAT	BMC IMB 5 V Standby Data Line
2	GND	Ground
3	SMB_IPMB_5VSB_CLK	BMC IMB 5 V Standby Clock Line

5.3.3 HSBP Header

Table 18. HSBP Header Pin-out (J1J7, J1J2)

Pin	Signal Name	Description
1	SMB_IPMB_5V_DAT	BMC IMB 5 V Data Line
2	GND	Ground
3	SMB_IPMB_5V_CLK	BMC IMB 5V Clock Line
4	GND – HSBP_A P5V – HSBP_B	Ground for HSBP A +5 V for HSBP B

5.3.4 SGPIO Header

Table 19. SGPIO Header Pin-out (J2H1, J1J5)

Pin	Signal Name	Description
1	SGPIO_CLOCK	SGPIO Clock Signal
2	SGPIO_LOAD	SGPIO Load Signal
3	SGPIO_DATAOUT	SGPIO Data Out
4	SGPIO_DATAIN	SGPIO Data In

5.3.5 SES I²C

Table 20. SES I²C Header Pin-out (J1J3)

Pin	Signal Name	Description
1	SMB_SAS_3V3_DAT	BMC SAS 3V Data Line
2	GND	Ground
3	SMB_SAS_3V3_CLK	BMC SAS 3V Clock Line

5.3.6 HDD Activity LED Header

Table 21. HDD Activity LED Header Pin-out (J2J3)

Pin	Signal Name	Description
1	LED_SCSI_CONN_N	HDD Activity LED Input
2	GND	Ground

5.4 Front Panel Connector

The workstation board provides a 24-pin SSI front panel connector (J1E4) for use with Intel® and third-party chassis. The following table provides the pin-out for this connector:

Table 22. Front Panel SSI Standard 24-pin Connector Pin-out (J1E4)

Pin	Signal Name	Description	Pin	Signal Name	Description
1	P3V3_STBY (Power_LED_Anode)	Power LED +	2	P3V3_STBY	Front Panel Power
3	Key	No Connection	4	P5V_STBY (ID LED Anode)	ID LED +
5	FP_PWR_LED_N	Power LED -	6	FP_ID_LED_BUF_N	ID LED -
7	P3V3 (HDD_ACTIVITY_Anode)	HDD Activity LED +	8	FP_LED_STATUS_GREEN_N	Status LED Green -
9	LED_HDD_ACTIVITY_N	HDD Activity LED -	10	FP_LED_STATUS_AMBER_N	Status LED Amber -
11	FP_PWR_BTN_N	Power Button	12	NIC1_ACT_LED_N	NIC 1 Activity LED -
13	GND (Power Button GND)	Power Button Ground	14	NIC1_LINK_LED_N	NIC 1 Link LED -
15	BMC_RST_BTN_N	Reset Button	16	SMB_SENSOR_3V3STB_DATA	SMB Sensor DATA
17	BND (Reset GND)	Reset Button Ground	18	SMB_SENSOR_3V3STB_CLK	SMB Sensor Clock
19	FP_ID_BTN_N	ID Button	20	FP_CHASSIS_INTRU	Chassis Intrusion
21	FM_SIO_TEMP_SENSOR	Front Panel Temperature Sensor	22	NIC2_ACT_LED_N	NIC 2 Activity LED
23	FP_NMI_BTN_N	NMI Button	24	NIC2_LINK_LED_N	NIC 2 Link LED

5.5 I/O Connectors

5.5.1 NIC Connectors

The workstation board provides two stacked RJ-45/2xUSB connectors side-by-side on the back edge of the board (JA6A1, JA6A2). The pin-out for NIC connectors is identical and defined in the following table:

Table 23. RJ-45 10/100/1000 NIC Connector Pin-out (JA6A1, JA6A2)

Pin	Signal Name
1	GND
2	P1V8_NIC
3	NIC_A_MDI3P
4	NIC_A_MDI3N
5	NIC_A_MDI2P
6	NIC_A_MDI2N

Pin	Signal Name
7	NIC_A_MDI1P
8	NIC_A_MDI1N
9	NIC_A_MDI0P
10	NIC_A_MDI0N
11 (D1)	NIC_LINKA_1000_N (LED)
12 (D2)	NIC_LINKA_100_N (LED)
13 (D3)	NIC_ACT_LED_N
14	NIC_LINK_LED_N
15	GND
16	GND

5.5.2 IDE Connector

The workstation board provides one legacy IDE ATA100 40-pin connector (J2J2). The pin-out is defined in the following table:

Table 24. IDE 40-pin Connector Pin-out (J2J2)

Pin	Signal Name	Pin	Signal Name
1	ESB_PLT_RST_IDE_N	2	GND
3	RIDE_DD_7	4	RIDE_DD_8
5	RIDE_DD_6	6	RIDE_DD_9
7	RIDE_DD_5	8	RIDE_DD_10
9	RIDE_DD_4	10	RIDE_DD_11
11	RIDE_DD_3	12	RIDE_DD_12
13	RIDE_DD_2	14	RIDE_DD_13
15	RIDE_DD_1	16	RIDE_DD_14
17	RIDE_DD_0	18	RIDE_DD_15
19	GND	20	KEY
21	RIDE_DDREQ	22	GND
23	RIDE_DIOW_N	24	GND
25	RIDE_DIOR_N	26	GND
27	RIDE_PIORDY	28	GND
29	RIDE_DDACK_N	30	GND
31	IRQ_IDE	32	TP_PIDE_32
33	RIDE_DA1	34	IDE_PRI_CBLSNS
35	RIDE_DA0	36	RIDE_DA2
37	RIDE_DCS1_N	38	RIDE_DCS3_N
39	LED_IDE_N	40	GND

5.5.3 SATA/SAS Connectors

The workstation board provides up to six SATA/SAS connectors:

- SATA-0 (J1J1)
- SATA-1 (J1H2)
- SATA-2/SAS-0 (J1H1)
- SATA-3/SAS-1 (J1G2)
- SATA-4/SAS-2 (J1G1)
- SATA-5/SAS-3 (J1F2)

The pin configuration for each connector is identical and is defined in the following table:

Table 25. SATA/SAS Connector Pin-out (J1J1, J1H2, J1H1, J1G2, J1G1, J1F2)

Pin	Signal Name	Description
1	GND	Ground
2	SATA/SAS_TX_P_C	Positive side of transmit differential pair
3	SATA/SAS_TX_N_C	Negative side of transmit differential pair
4	GND	Ground
5	SATA/SAS_RX_N_C	Negative side of receive differential pair
6	SATA/SAS_RX_P_C	Positive side of receive differential pair
7	GND	Ground

5.5.4 Serial Port Connectors

The workstation board provides one external DB9 Serial A port (J7A1) and one internal 9-pin serial B header (J1B1). The following tables define the pin-outs.

Table 26. External DB9 Serial A Port Pin-out (J7A1)

Pin	Signal Name	Description
1	SPA_DCD	DCD (carrier detect)
2	SPA_SIN_L	RXD (receive data)
3	SPA_SOUT_N	TXD (Transmit data)
4	SPA_DTR	DTR (Data terminal ready)
5	GND	Ground
6	SPA_DSR	DSR (data set ready)
7	SPA_RTS	RTS (request to send)
8	SPA_CTS	CTS (clear to send)
9	SPA_RI	RI (Ring Indicate)

Table 27. Internal 9-pin Serial B Header Pin-out (J1B1)

Pin	Signal Name	Description
1	SPB_DCD	DCD (carrier detect)
2	SPB_DSR	DSR (data set ready)
3	SPB_SIN_L	RXD (receive data)
4	SPB_RTS	RTS (request to send)
5	SPB_SOUT_N	TXD (Transmit data)
6	SPB_CTS	CTS (clear to send)
7	SPB_DTR	DTR (Data terminal ready)
8	SPB_RI	RI (Ring indicate)
9	SPB_EN_N	Enable

5.5.5 Keyboard and Mouse Connector

Two stacked PS/2* ports (J9A1) support a keyboard and a mouse. Either PS/2 port can support a mouse or keyboard. The following table details the pin-out of the PS/2 connectors.

Table 28. Stacked PS/2 Keyboard and Mouse Port Pin-out (J9A1)

Pin	Signal Name	Description
1	KB_DATA_F	Keyboard data
2	TP_PS2_2	Test point – keyboard
3	GND	Ground
4	P5V_KB_F	Keyboard/mouse power
5	KB_CLK_F	Keyboard clock
6	TP_PS2_6	Test point – keyboard/mouse
7	MS_DAT_F	Mouse data
8	TP_PS2_8	Test point – keyboard/mouse
9	GND	Ground
10	P5V_KB_F	Keyboard/mouse power
11	MS_CLK_F	Mouse clock
12	TP_PS2_12	Test point – keyboard/mouse
13	GND	Ground
14	GND	Ground
15	GND	Ground
16	GND	Ground
17	GND	Ground

5.5.6 USB Connector

The following table describes the pin-out of the external USB connectors (JA6A1, JA6A2) found on the back edge of the workstation board:

Table 29. External USB Connector Pin-out (JA6A1, JA6A2)

Pin	Signal Name	Description
1	USB_OC	USB_PWR
2	USB_PN	DATAL0 (Differential data line paired with DATAH0)
3	USB_PP	DATAH0 (Differential data line paired with DATAL0)
4	GND	Ground

One 2x5 connector on the workstation board (J3J1) provides an option to support an additional two USB ports. The pin-out of the connector is detailed in the following table:

Table 30. Internal USB Connector Pin-out (J3J1)

Pin	Signal Name	Description
1	USB2_VBUS5	USB power (port 5)
2	USB2_VBUS4	USB power (port 4)
3	USB_ESB_P5N_CONN	USB port 5 negative signal
4	USB_ESB_P4N_CONN	USB port 4 negative signal
5	USB_ESB_P5P_CONN	USB port 5 positive signal
6	USB_ESB_P4P_CONN	USB port 4 positive signal
7	Ground	
8	Ground	
9	Key	No pin
10	TP_USB_ESB_NC	Test point

5.5.7 CD-IN Header

The following table details the pin-out of the internal CD-IN header (J4A1) found near the audio connector.

Table 31. CD-IN Header Pin-out (J4A1)

Pin	Signal Name	Description
1	AUD_CD_L	CD Input Left Channel
2	AUD_CD_CMN	CD Input Reference Ground
3	AUD_CD_CMN	CD Input Reference Ground
4	AUD_CD_R	CD Input Right Channel

5.5.8 Audio Connectors

The workstation board provides one stacked audio connector on the back edge of the board (J5A1). This stacked connector provides three jacks for audio connections (Line In, Line Out, and MIC In).

5.6 Fan Headers

The workstation board provides four SSI-compliant 4-pin and four SSI-compliant 6-pin fan headers to be used as CPU, and I/O cooling fans.

3-pin fans are supported on all fan headers. 6-pin fans are supported on headers J3H4, J3H3, J3H2, and J3H1.

4-pin fans are supported on headers J9J1, J5J1, J3H4, J3H3, J9B4, and J9B3. 4-pin fans are not supported on headers J3H2 and J3H1, since these headers are tied to the CPU1 PWM. Do not use these fan headers for CPU cooling fans. The pin configuration for each of the 4-pin and 6-pin fan headers is identical and is defined in tables below.

- Two 4-pin fan headers are designated as processor cooling fans:
 - CPU1 fan (J9J1)
 - CPU2 fan (J5J1)
- Four 6-pin fan headers are designated as hot-swap system fans:
 - Hot-swap system fan 1 (J3H4)
 - Hot-swap system fan 2 (J3H3)
 - Hot-swap system fan 3 (J3H2)
 - Hot-swap system fan 4 (J3H1)
- Two 4-pin fan headers are designated as rear system fans:
 - System fan 5 (J9B4)
 - System fan 6 (J9B3)

Table 32. SSI 4-pin Fan Header Pin-out (J9J1, J5J1, J9B3, and J9B4)

Pin	Signal Name	Type	Description
1	Ground	GND	Ground is the power supply ground
2	12V	Power	Power supply 12 V
3	Fan Tach	In	FAN_TACH signal is connected to the BMC to monitor the fan speed
4	Fan PWM	Out	FAN_PWM signal to control fan speed

Table 33. SSI 6-pin Fan Header Pin-out (J3H1, J3H2, J3H3, and J3H4)

Pin	Signal Name	Type	Description
1	Ground	GND	Ground is the power supply ground
2	12V	Power	Power supply 12 V
3	Fan Tach	In	FAN_TACH signal is connected to the BMC to monitor the fan speed
4	Fan PWM	Out	FAN_PWM signal to control fan speed
5	Fan Presence	In	Indicates the fan is present
6	Fan Fault LED	Out	Lights the fan fault LED

Note: Intel Corporation workstation boards support peripheral components and contain a number of high-density VLSI and power delivery components that need adequate airflow to cool. Intel's own chassis are designed and tested to meet the intended thermal requirements of these components when the fully integrated system is used together. It is the responsibility of the system integrator that chooses not to use Intel developed server building blocks to consult vendor datasheets and operating parameters to determine the amount of air flow required for their specific application and environmental conditions. Intel Corporation can not be held responsible if components fail or the server board does not operate correctly when used outside any of their published operating or non-operating limits.

6. Jumper Blocks

The workstation board has several 3-pin jumper blocks that you can use to configure, protect, or recover specific features of the server board. Pin 1 on each jumper block can be identified by the following symbol on the silkscreen: ▼

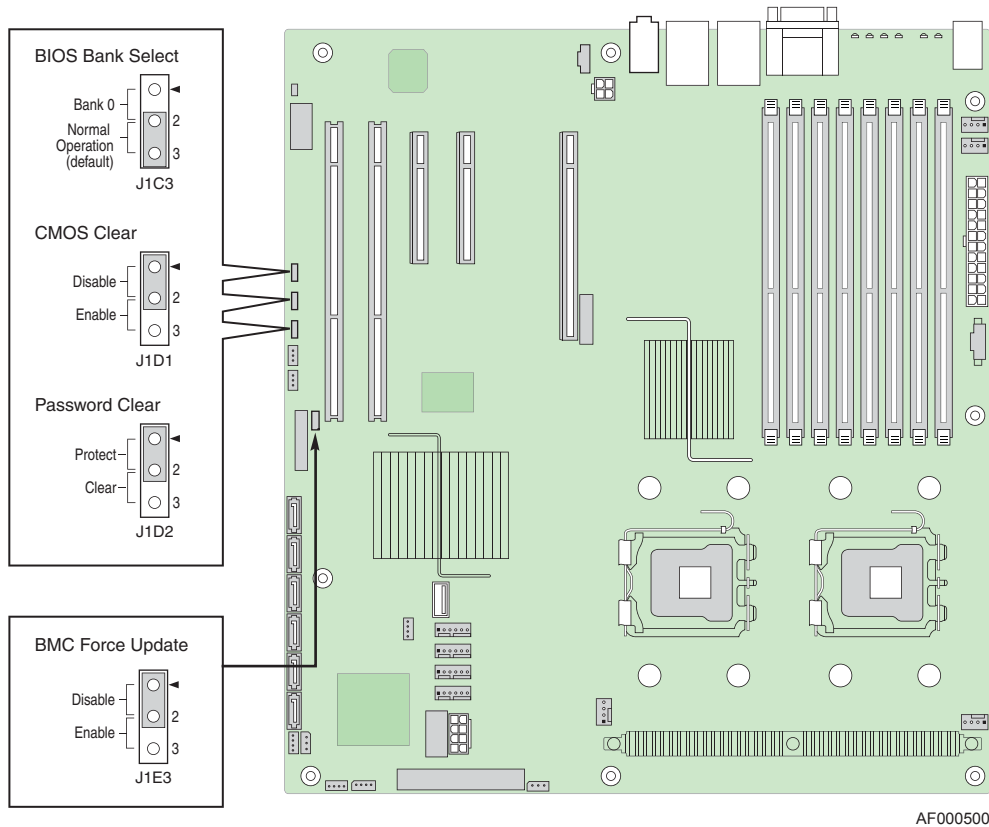

Figure 19. Jumper Blocks (J1C3, J1D1, J1D2, and J1E32)

Table 34. Server Board Jumpers (J1C3, J1D1, J1D2, and J1E3)

Jumper Name	Pins	System Results
J1C3: BIOS Bank Select	1-2	If these pins are jumper the system will boot from an alternate BIOS image.
	2-3	System is configured for normal operation. (Default)
J1D1: CMOS Clear	1-2	These pins should have a jumper in place for normal system operation. (Default)
	2-3	If these pins are jumpered, the CMOS settings are cleared immediately upon removal of AC power. These pins should not be jumpered for normal operation
J1D2: Password Clear	1-2	These pins should have a jumper in place for normal system operation. (Default)
	2-3	If these pins are jumpered, administrator and user passwords are cleared immediately upon removal of AC power. These pins should not be jumpered for normal operation.
J1E3: BMC Forced Update	1-2	BMC Firmware Force Update Mode – Disabled (Default)
	2-3	BMC Firmware Force Update Mode – Enabled

6.1 CMOS Clear and Password Reset Usage Procedure

The CMOS Clear (J1D1) and Password Reset (J1D2) recovery features are designed such that the necessary operation can be achieved with minimal system down time. The usage procedure for these two features has changed from previous generation Intel server boards. The following procedure outlines the new usage model.

1. Power down server. Do not unplug the power cord.
2. Open the server chassis. For instructions, see your server chassis documentation.
3. Move jumper from the default operating position, covering pins 1 and 2, to the reset/clear position, covering pins 2 and 3.
4. Remove AC power.
5. Wait five seconds.
6. Move the jumper back to default position, covering pins 1 and 2.
7. Close the server chassis.
8. Apply AC power.
9. Power up the server.

The password and/or CMOS is now cleared. You can reset it by going into the BIOS setup.

Note: Removing AC Power before performing the CMOS Clear operation causes the system to automatically power up and immediately power down, after the procedure is followed and AC power is re-applied. If this happens, remove the AC power cord again, wait 30 seconds, and re-install the AC power cord. Power up the system and proceed to the <F2> BIOS Setup Utility to reset the required settings.

6.2 BMC Force Update Procedure

When performing a standard BMC firmware update procedure, the update utility places the BMC into update mode, allowing the firmware to load safely onto the flash device. In the unlikely event the BMC firmware update process fails due to the BMC not being in the proper update state, the server board provides a BMC Force Update jumper (J1E3) which forces the BMC into the proper update state. The following procedure should be followed in the event the standard BMC firmware update process fails.

1. Power down and remove the AC power cord.
2. Open the server chassis. See your server chassis documentation for instructions.
3. Move jumper from the default operating position, covering pins 1 and 2, to the enabled position, covering pins 2 and 3.
4. Close the server chassis.
5. Reconnect the AC cord and power up the server.
6. Perform the BMC firmware update procedure as documented in the README.TXT file that is included in the given BMC firmware update package. After successful completion of the firmware update process, the firmware update utility may generate an error stating the BMC is still in update mode.

7. Power down and remove the AC power cord.
8. Open the server chassis.
9. Move jumper from the enabled position, covering pins 2 and 3 to the disabled position, covering pins 1 and 2.
10. Close the server chassis.
11. Reconnect the AC cord and power up the server.

Note: Normal BMC functionality is disabled with the Force BMC Update jumper set to the enabled position. You should never run the server with the BMC Force Update jumper set in this position. You should only use this jumper setting when the standard firmware update process fails. This jumper should remain in the default/disabled position when the server is running normally.

6.3 BIOS Select Jumper

The jumper block at J1C3, located at the left of PCI-X* slot 1, is used to select which BIOS image the system will boot to. Pin 1 on the jumper is identified with a '▼'. You should only move this jumper to force the BIOS to boot to the secondary bank, which may hold a different version of BIOS.

The BIOS update is supported when the Recovery jumper is set on either pins 1-2 (recovery mode), or pins 2-3 connected (normal mode).

To perform a normal BIOS update, perform the following steps:

1. Boot the system with the jumper covering pins 2 and 3.
2. Update the BIOS using iFlash or the Intel® One Flash Update (OFU) utility.
3. Reset the system.

The current BIOS will validate and then boot from the new BIOS.

If the system cannot boot, perform the following steps to recover:

1. Boot the system with the jumper covering pins 1 and 2.
2. Update the BIOS using iFlash or the Intel® One Flash Update (OFU) utility.
3. Power down the server and unplug the AC power cord.
4. Move the recovery jumper back to the normal position.
5. Plug in the power cord and power on the system.

The system will boot from the new BIOS.

7. Intel® Light Guided Diagnostics

The workstation boards have several onboard diagnostic LEDs to assist in troubleshooting board-level issues. This section provides a description the location and function of each LED on the workstation board. For a more detailed description of what drives the diagnostic LED operation, see the *Intel® S5000 Server Board Family Datasheet*.

7.1 5 Volt Standby LED

Several server management features of this workstation board require that a 5 volt stand-by voltage be supplied from the power supply. Some of the features and components that require this voltage be present when the system is “Off” include the BMC within the ESB2-E and onboard NICs.

The LED is located just to the right of the CMOS Battery in the center of the workstation board (labeled 5VSB_LED) is illuminated when AC power is applied to the platform and 5-V standby voltage is supplied to the server board by the power supply.

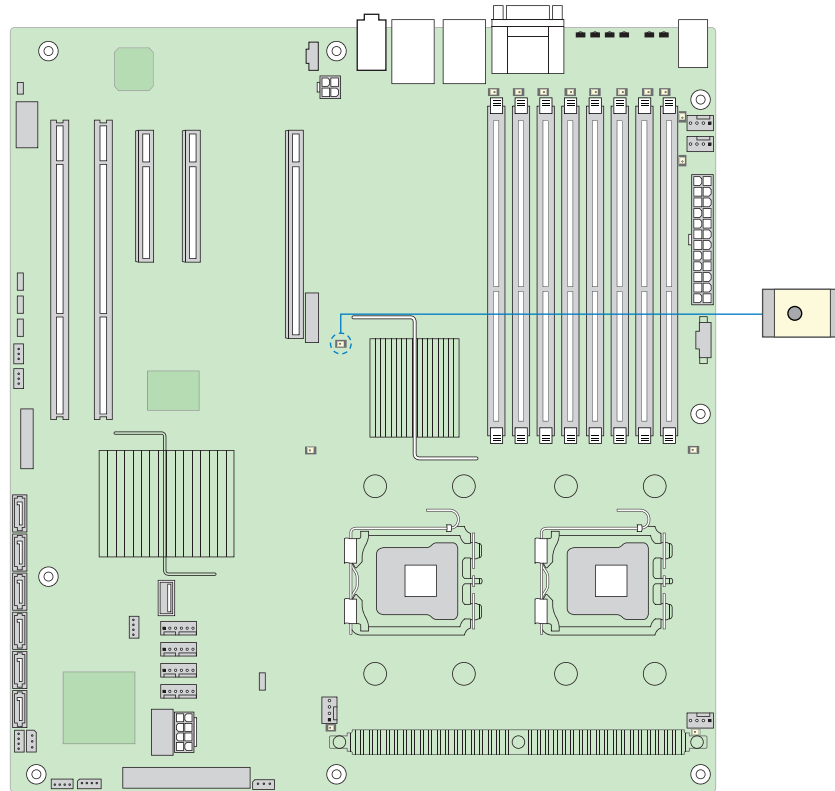

AF001031

Figure 20. 5 Volt Standby Status LED Location

7.2 Fan Fault LEDs

Fan fault LEDs are present for the two CPU fans and the two rear system fans. The two CPU fan fault LEDs are located next to each CPU fan header. The two rear system fan fault LEDs are located next to each rear system fan header are shown in the following figure:

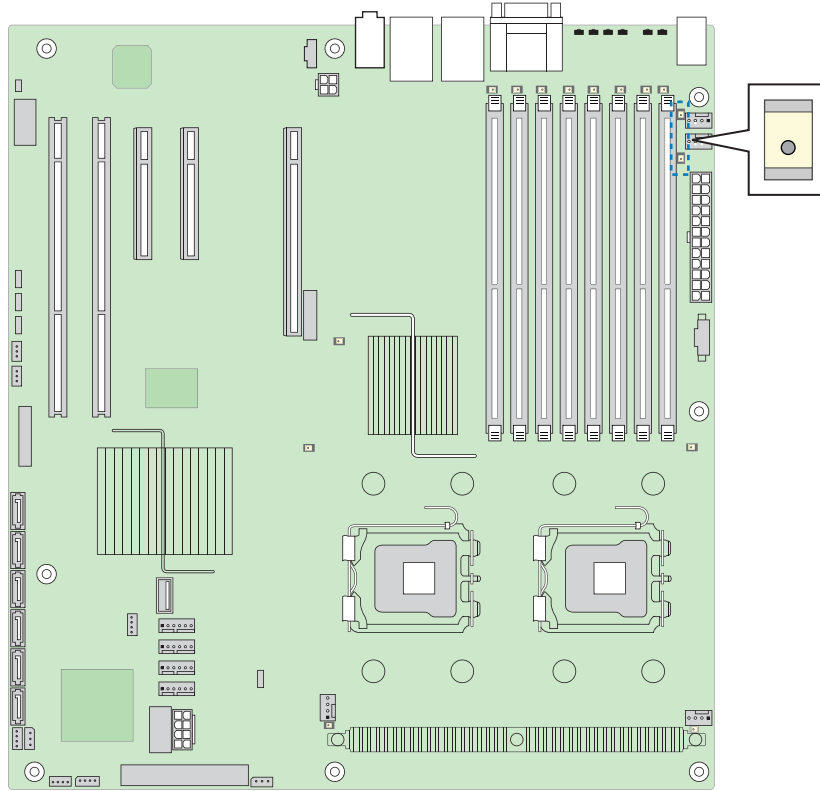

AF001032

Figure 21. Fan Fault LED Locations

7.3 System ID LED and System Status LED

The workstation board provides LEDs for both system ID and system status. These LEDs are located in the rear I/O area of the workstation board between the PS/2* mouse/keyboard stacked connectors and the video/serial stacked connectors. The following figure shows the locations of these LEDs:

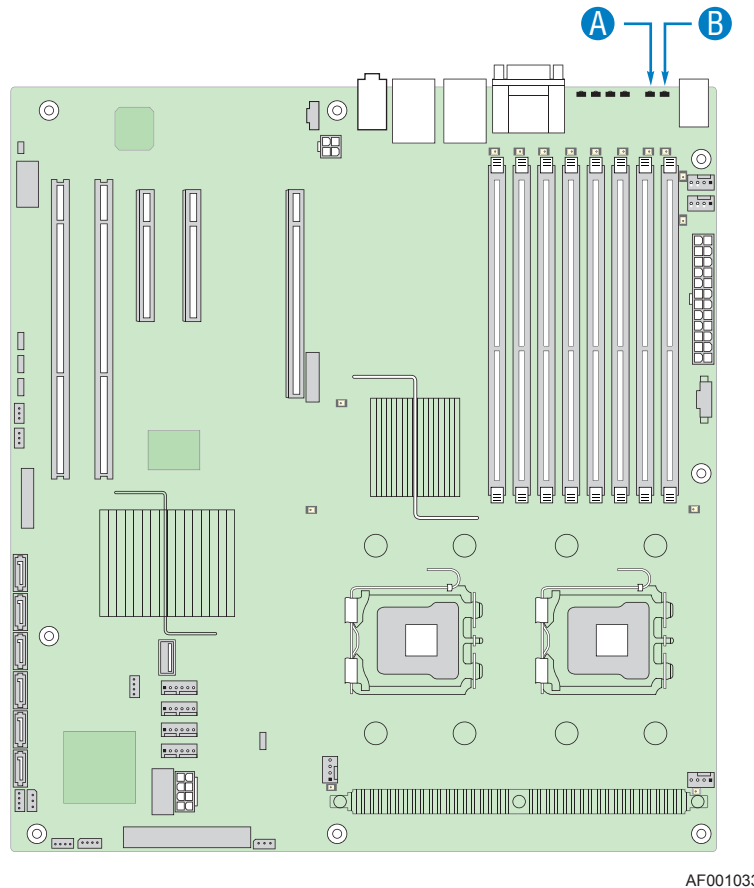

- A. System ID LED
- B. System Status LED

Figure 22. System ID LED and System Status LED Locations

You can illuminate the blue System ID LED using either of two mechanisms:

- By pressing the System ID Button on the system front panel, the ID LED will display a solid blue color, until the button is pressed again.
- By issuing the appropriate hex IPMI “Chassis Identify” value, the ID LED will either blink blue for 15 seconds and turn off or will blink indefinitely until the appropriate hex IPMI Chassis Identify value is issued to turn it off.

The bi-color System Status LED operates as follows:

Table 35. System Status LED

Color	State	Criticality	Description
Off	N/A	Not ready	AC power off
Green/ Amber	Alternating Blink	Not ready	Pre DC Power On – 15-20 second BMC Initialization when AC is applied to the server. Control Panel buttons are disabled until BMC initialization is complete.
Green	Solid on	System OK	System booted and ready.
Green	Blink	Degraded	System degraded <ul style="list-style-type: none"> ▪ Unable to use all of the installed memory (more than one DIMM installed). ▪ Correctable errors over a threshold of 10 and migrating to a spare DIMM (memory sparing). This indicates the user no longer has spared DIMMs indicating a redundancy lost condition. Corresponding DIMM LED should light up. ▪ In mirrored configuration, when memory mirroring takes place and system loses memory redundancy. ▪ Redundancy loss such as power-supply or fan. This does not apply to non-redundant subsystems. ▪ PCI Express* link errors ▪ CPU failure/disabled – if there are two processors and one of them fails. ▪ Fan alarm – Fan failure. Number of operational fans should be more than minimum number needed to cool the system. ▪ Non-critical threshold crossed – Temperature and voltage
Amber	Blink	Non-critical	Non-fatal alarm – system is likely to fail <ul style="list-style-type: none"> ▪ Critical voltage threshold crossed ▪ VRD hot-asserted ▪ Minimum number of fans needed to cool the system not present or failed ▪ In non-sparing and non-mirroring mode if the threshold of ten correctable errors is crossed within the window
Amber	Solid on	Critical, non-recoverable	Fatal alarm – system has failed or shut down <ul style="list-style-type: none"> ▪ DIMM failure when there is one DIMM present, no good memory is present ▪ Run-time memory uncorrectable error in non-redundant mode ▪ IERR signal asserted ▪ Processor 1 missing ▪ Temperature (CPU ThermTrip, memory TempHi, critical threshold crossed) ▪ No power good – power fault ▪ Processor configuration error (for example, processor stepping mismatch)

7.3.1 System Status LED – BMC Initialization

When the AC power is first applied to the system and 5V-STBY is present, the BMC on the server board requires 20-30 seconds to initialize. During this time, the system status LED will blink, alternating between amber and green, and the power button functionality of the control panel is disabled, preventing the server from powering up. Once BMC initialization is completed, the status LED will stop blinking and the power button functionality is restored and can be used to turn on the server.

7.4 DIMM Fault LEDs

The workstation board provides a memory fault LED for each DIMM socket. These LEDs are located towards the rear of the server board next to each DIMM connector.

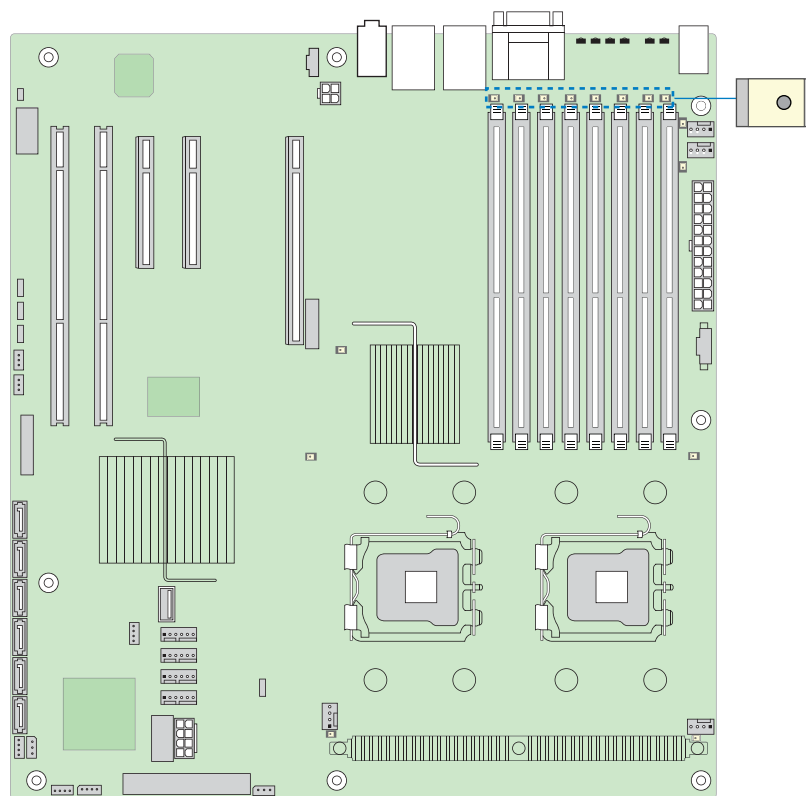

AF001034

Figure 23. DIMM Fault LED Locations

7.5 Processor Fault LEDs

The workstation board provides a fault LED for each processor socket. These LEDs are located near the processor sockets.

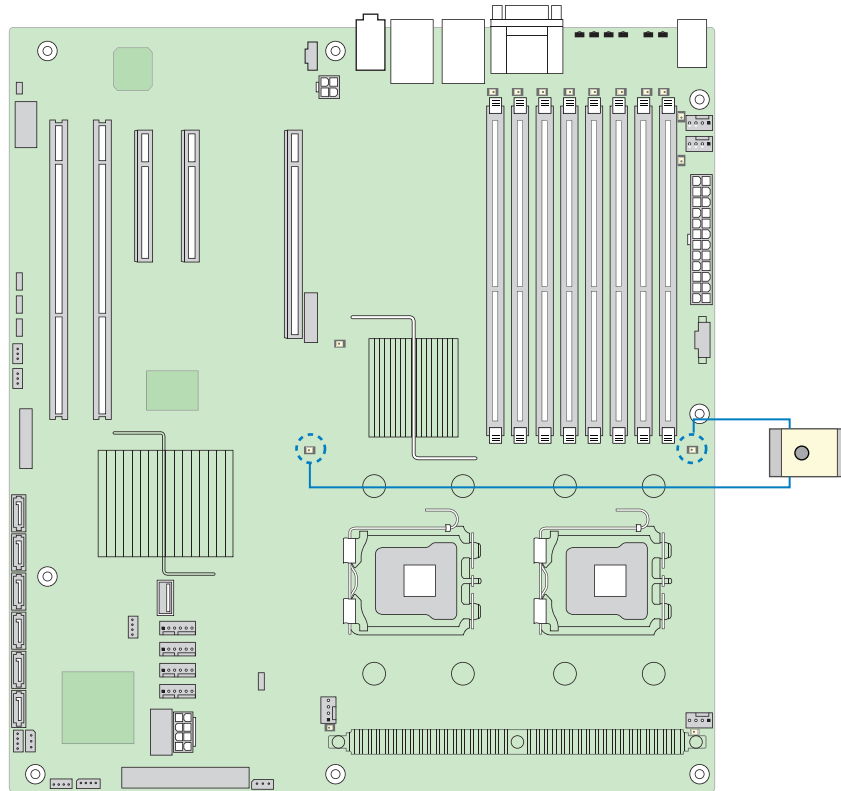

AF001035

Figure 24. Processor Fault LED Locations

7.6 Post Code Diagnostic LEDs

POST code diagnostic LEDs are located on the back edge of the workstation board in the rear I/O area of the workstation board between the PS/2 mouse/keyboard stacked connectors and the serial connector.

During the system boot process, the BIOS executes a number of platform configuration processes, each of which is assigned a specific hex POST code number. As each configuration routine is started, the BIOS displays the given POST code to the POST code diagnostic LEDs on the back edge of the workstation board. To assist in troubleshooting a system hang during the POST process, you can use the Diagnostic LEDs to identify the last POST process executed. See Appendix C for a complete description of how these LEDs are read and for a list of all supported POST codes.

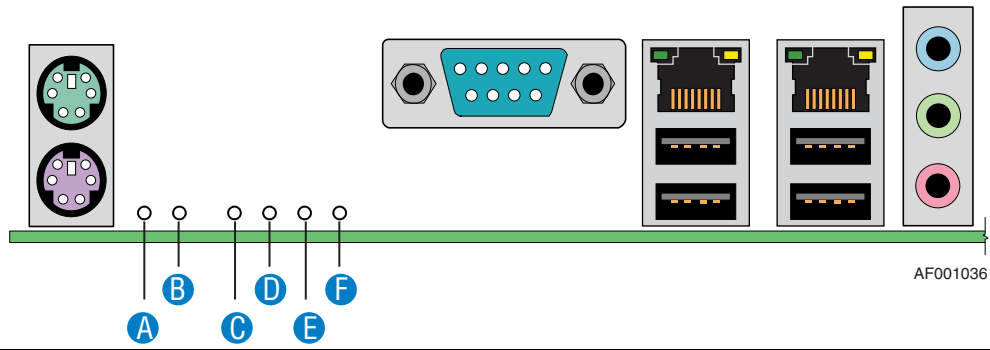

A. Status LED	D. Bit 2 LED (POST LED)
B. ID LED	E. Bit 1 LED (POST LED)
C. MSB LED (POST LED)	F. LSB LED (POST LED)

Figure 25. POST Code Diagnostic LED Location

8. Design and Environmental Specifications

8.1 Intel® Workstation Board S5000XVN Design Specifications

The operation of the workstation board at conditions beyond those shown in the following table may cause permanent damage to the system. Exposure to absolute maximum rating conditions for extended periods may affect system reliability.

Table 36. Workstation Board Design Specifications

Operating Temperature	0° C to 55° C ¹ (32° F to 131° F)
Non-Operating Temperature	-40° C to 70° C (-40° F to 158° F)
DC Voltage	± 5% of all nominal voltages
Shock (Unpackaged)	Trapezoidal, 50 G, 170 inches/sec
Shock (Packaged)	
<20 pounds	36 inches
20 to <40 pounds	30 inches
40 to <80 pounds	24 inches
80 to <100 pounds	18 inches
100 to <120 pounds	12 inches
120 pounds	9 inches
Vibration (Unpackaged)	5 Hz to 500 Hz 3.13 g RMS random

Note:

¹ Chassis design must provide proper airflow to avoid exceeding the Dual-Core Intel® Xeon® processor 5000 sequence maximum case temperature.

Disclaimer Note: Intel Corporation workstation boards contain a number of high-density VLSI and power delivery components that need adequate airflow to cool. Intel ensures through its own chassis development and testing that when Intel server building blocks are used together, the fully integrated system will meet the intended thermal requirements of these components. It is the responsibility of the system integrator who chooses not to use Intel developed workstation building blocks to consult vendor datasheets and operating parameters to determine the amount of air flow required for their specific application and environmental conditions. Intel Corporation cannot be held responsible, if components fail or the workstation board does not operate correctly when used outside any of their published operating or non-operating limits.

8.2 Board-level MTBF

The predicted board Mean Time Between Failures is 97,549 hours of operation. As of this writing, actual MTBF testing across multiple systems is complete with a demonstrated 25,222 hours. Since our validation test is only run up to about 25,000 hours across multiple servers, we still maintain that actual MTBF data will likely be over 97,549 hours of operation based on statistical regression.

8.3 Workstation Board Power Requirements

This section provides power supply design guidelines for a system using the Intel® Workstation Board S5000XVN including voltage and current specifications, and power supply on/off sequencing characteristics. The following diagram shows the power distribution implemented on this workstation boards:

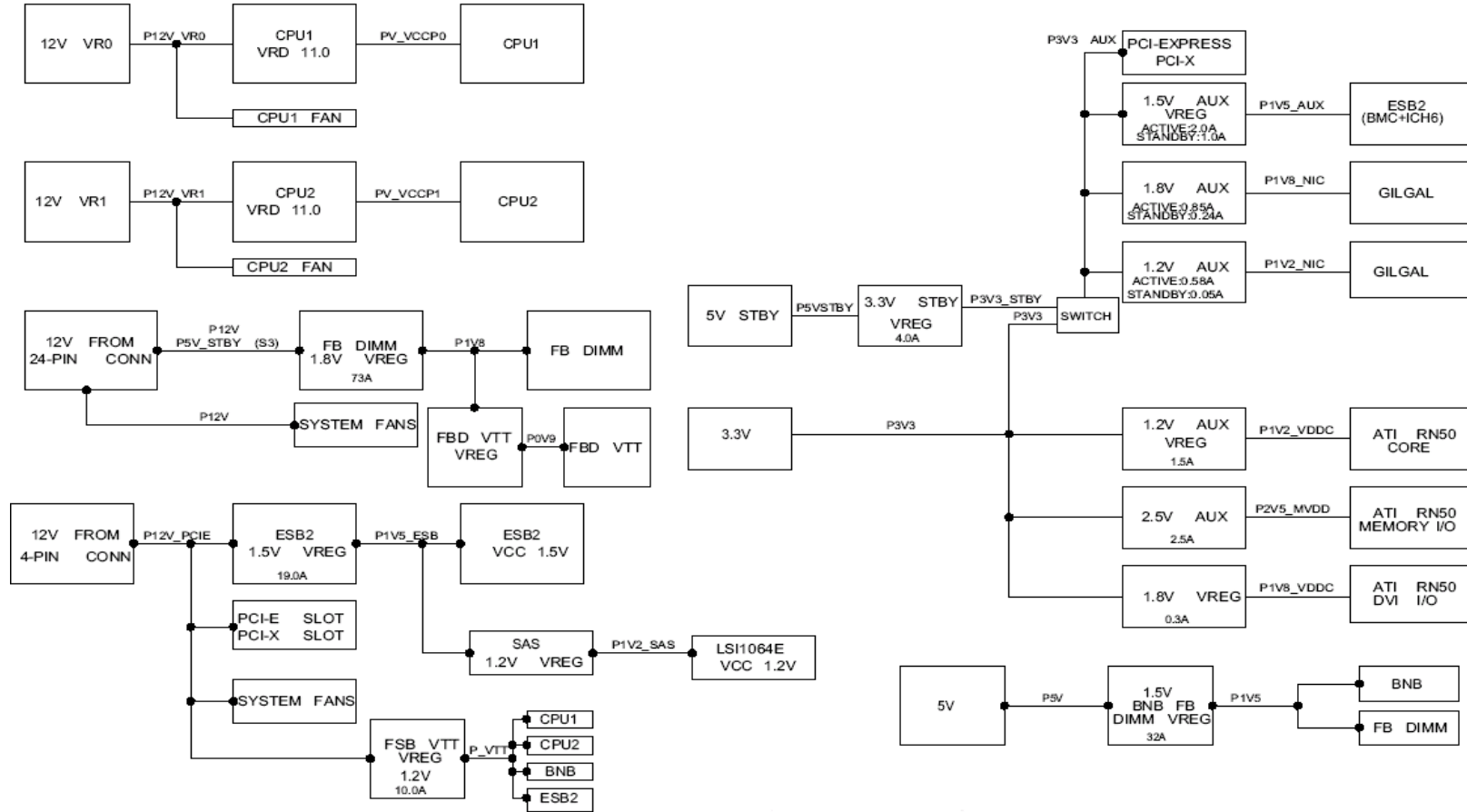

Figure 26. Power Distribution Block Diagram

8.3.1 Processor Power Support

The workstation board supports the Thermal Design Point (TDP) guideline for Intel® Xeon® processors. The Flexible Motherboard Guidelines (FMB) also were followed to help determine the suggested thermal and current design values for anticipating future processor needs. The following table provides maximum values for I_{CC}, TDP power, and T_{CASE} for the Intel® Xeon® processor 5000 sequence family:

Table 37. Intel® Xeon® Processor Dual Processor TDP Guidelines

TDP Power	Max TCASE	I _{CC} MAX
130 W	70° C	150 A

Note: These values are for reference only. The Intel® Xeon® processor 5000 sequence Datasheet contains the actual specifications for the processor. If the values found in the Intel(r) Xeon® processor 5000 sequence Datasheet are different than those published here, the Dual-Core Intel® Xeon® processor 5000 sequence Datasheet values will supersede these, and should be used.

8.4 Power Supply Output Requirements

This section is for reference purposes only. The intent is to provide guidance to system designers to determine a power supply for use with this server board. This section specifies the power supply requirements Intel used to develop a power supply for its workstation system.

The combined power of all outputs shall not exceed the rated output power of the power supply. The power supply must meet both static and dynamic voltage regulation requirements for the minimum loading conditions.

Table 38. 550 W Load Ratings

Voltage	Minimum Continuous	Maximum Continuous	Peak
+3.3 V	1.5 A	24 A	
+5 V	1.0 A	24 A	
+12 V1	0.5 A	16 A	18 A
+12 V2	0.5 A	16 A	18 A
+12 V3	0.5 A	14 A	
+12 V4	0.5 A	8 A	13 A
-12 V	0 A	0.5 A	
+5 VSB	0.1 A	3.0 A	3.5 A

Note:

1. Maximum continuous total DC output power should not exceed 550 W.
2. Maximum continuous combined load on +3.3 VDC and +5 VDC outputs shall not exceed 140 W.
3. Maximum peak total DC output power should not exceed 660 W.
4. Peak power and current loading shall be supported for a minimum of 12 seconds.
5. Maximum combined current for the 12 V outputs shall be 41 A.
6. Peak current for the combined 12 V outputs shall be 50 A.

8.4.1 Grounding

The grounds of the pins of the power supply output connector provide the power return path. The output connector ground pins is connected to safety ground (power supply enclosure). This grounding should be designed to ensure passing the maximum allowed common mode noise levels.

8.4.2 Standby Outputs

The 5 VSB output shall be present when an AC input greater than the power supply turn on voltage is applied.

8.4.3 Remote Sense

The power supply has remote sense return to regulate out ground drops for all output voltages: +3.3 V, +5 V, +12 V1, +12 V2, +12 V3, -12 V, and 5 VSB. The power supply uses remote sense (3.3 VS) to regulate out drops in the system for the +3.3 V output.

The +5 V, +12 V1, +12 V2, +12 V3, -12 V and 5 VSB outputs only use remote sense referenced to the remote sense return signal. The remote sense input impedance to the power supply must be greater than 200 Ω on 3.3 VS and 5 VS. This is the value of the resistor connecting the remote sense to the output voltage internal to the power supply.

Remote sense must be able to regulate out a minimum of a 200 mV drop on the +3.3 V output. The remote sense return must be able to regulate out a minimum of a 200 mV drop in the power ground return. The current in any remote sense line shall be less than 5 mA to prevent voltage sensing errors.

The power supply must operate within specification over the full range of voltage drops from the power supply's output connector to the remote sense points.

8.4.4 Voltage Regulation

The power supply output voltages must stay within the following voltage limits when operating at steady state and dynamic loading conditions. These limits include the peak-peak ripple/noise.

Table 39. Voltage Regulation Limits

Parameter	Tolerance	Minimum	Nominal	Maximum	Units
+3.3V	- 5%/+5%	+3.14	+3.30	+3.46	V _{rms}
+5V	- 5%/+5%	+4.75	+5.00	+5.25	V _{rms}
+12V ¹	- 5%/+5%	+11.40	+12.00	+12.60	V _{rms}
+12V ²	- 5%/+5%	+11.40	+12.00	+12.60	V _{rms}
+12V ³	- 5%/+5%	+11.40	+12.00	+12.60	V _{rms}
+12V ⁴	- 5%/+5%	+11.40	+12.00	+12.60	V _{rms}
- 12V	- 5%/+9%	- 11.40	-12.00	-13.08	V _{rms}
+5VSB	- 5%/+5%	+4.75	+5.00	+5.25	V _{rms}

Notes:

1. Maximum continuous total output power should not exceed 670 W.
2. Maximum continuous load on the combined 12 V output shall not exceed 48 A.
3. Peak load on the combined 12 V output shall not exceed 52 A.
4. Peak total DC output power should not exceed 730 W.

8.4.5 Dynamic Loading

The output voltages shall remain within limits for the step loading and capacitive loading specified in the table below. The load transient repetition rate shall be tested between 50 Hz and 5 kHz at duty cycles ranging from 10%-90%. The load transient repetition rate is only a test specification. The step load may occur anywhere within the minimum load to the maximum load conditions.

Table 40. Transient Load Requirements

Output	Step Load Size ¹	Load Slew Rate	Test Capacitive Load
+3.3 V	7.0 A	0.25 A/ sec	4700 F
+5 V	7.0 A	0.25 A/ sec	1000 F
+12 V	25 A	0.25 A/ sec	4700 F
+5 VSB	0.5 A	0.25 A/ sec	20 F

Note:

Step loads on each 12 V output may happen simultaneously.

8.4.6 Capacitive Loading

The power supply shall be stable and meet all requirements with the following capacitive loading ranges.

Table 41. Capacitive Loading Conditions

Output	Minimum	Maximum	Units
+3.3 V	250	6800	F
+5 V	400	4700	F
+12 V ^{1, 2, 3, 4}	500 each	11,000	F
-12 V	1	350	F
+5 VSB	20	350	F

Note:

1. Maximum continuous total output power should not exceed 670 W.
2. Maximum continuous load on the combined 12 V output shall not exceed 48 A.
3. Peak load on the combined 12 V output shall not exceed 52 A.
4. Peak total DC output power should not exceed 730 W.

8.4.7 Ripple/Noise

The maximum allowed ripple/noise output of the power supply is defined in the following table. This is measured over a bandwidth of 0Hz to 20MHz at the power supply output connectors. A 10 F tantalum capacitor in parallel with a 0.1 F ceramic capacitor are placed at the point of measurement.

Table 42. Ripple and Noise

+3.3 V	+5 V	+12 V 1, 2, 3, 4	-12 V	+5 VSB
50mVp-p	50mVp-p	120mVp-p	120mVp-p	50mVp-p

Note:

1. Maximum continuous total output power should not exceed 670 W.
2. Maximum continuous load on the combined 12 V output shall not exceed 48 A.
3. Peak load on the combined 12 V output shall not exceed 52 A.
4. Peak total DC output power should not exceed 730 W.

8.4.8 Timing Requirements

The following are the timing requirements for the power supply operation. The output voltages must rise from 10% to within regulation limits ($T_{\text{vout_rise}}$) within 5 to 70 ms. 5 VSB is allowed to rise from 1.0 to 25 ms. All outputs must rise monotonically. Each output voltage shall reach regulation within 50 ms ($T_{\text{vout_on}}$) of each other during turn on of the power supply. Each output voltage shall fall out of regulation within 400 msec ($T_{\text{vout_off}}$) of each other during turn off.

The following tables and diagrams show the timing requirements for the power supply being turned on and off via the AC input with PSON held low, and the PSON signal with the AC input applied.

Table 43. Output Voltage Timing

Item	Description	Minimum	Maximum	Units
$T_{\text{vout_rise}}$	Output voltage rise time from each main output.	5.0 ¹	70 ¹	ms
$T_{\text{vout_on}}$	All main outputs must be within regulation of each other within this time.	N/A	50	ms
$T_{\text{vout_off}}$	All main outputs must leave regulation within this time.	N/A	400	ms

Note:

The 5VSB output voltage rise time is from 1.0 ms to 25 ms.

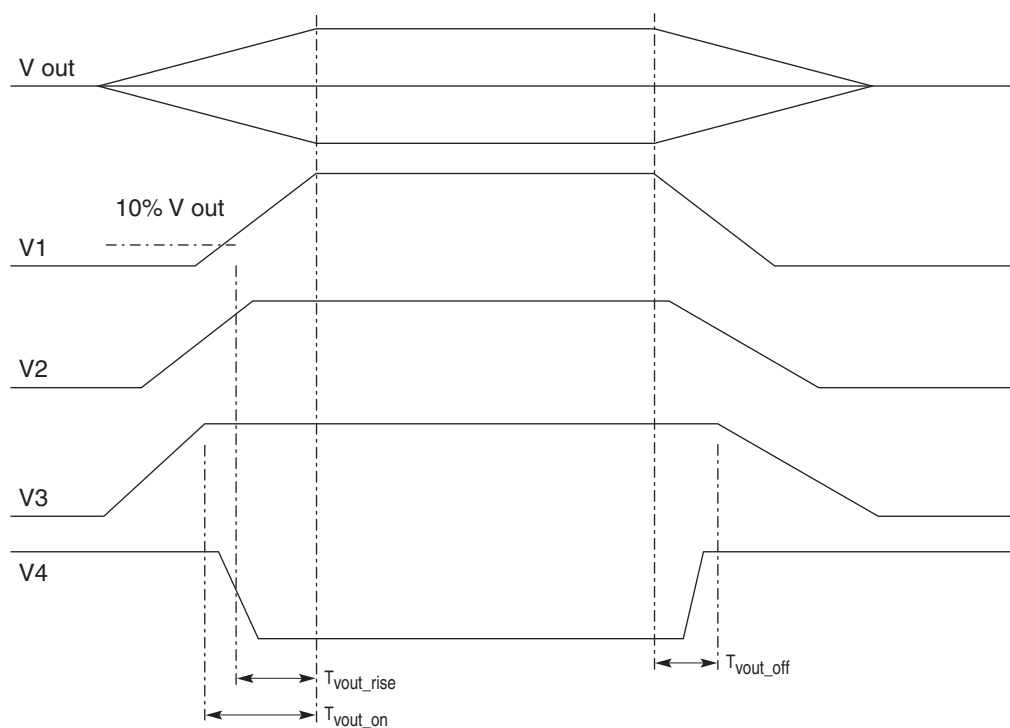

TP02313

Figure 27. Output Voltage Timing**Table 44. Turn On/Off Timing**

Item	Description	Minimum	Maximum	Units
$T_{sb_on_delay}$	Delay from AC being applied to 5VSB being within regulation.		1500	ms
$T_{ac_on_delay}$	Delay from AC being applied to all output voltages being within regulation.		2500	ms
T_{vout_holdup}	Time all output voltages stay within regulation after loss of AC.	21		ms
T_{pwok_holdup}	Delay from loss of AC to de-assertion of PWOK.	20		ms
$T_{pson_on_delay}$	Delay from PSON# active to output voltages within regulation limits.	5	400	ms
T_{pson_pwok}	Delay from PSON# deactivate to PWOK being de-asserted.		50	ms
T_{pwok_on}	Delay from output voltages within regulation limits to PWOK asserted at turn on.	100	500	ms
T_{pwok_off}	Delay from PWOK de-asserted to output voltages (3.3 V, 5 V, 12 V, -12 V) dropping out of regulation limits.	1		ms
T_{pwok_low}	Duration of PWOK being in the de-asserted state during an off/on cycle using AC or the PSON signal.	100		ms
T_{sb_vout}	Delay from 5 VSB being in regulation to O/Ps being in regulation at AC turn on.	50	1000	ms
T_{5VSB_holdup}	Time the 5 VSB output voltage stays within regulation after loss of AC.	70		ms

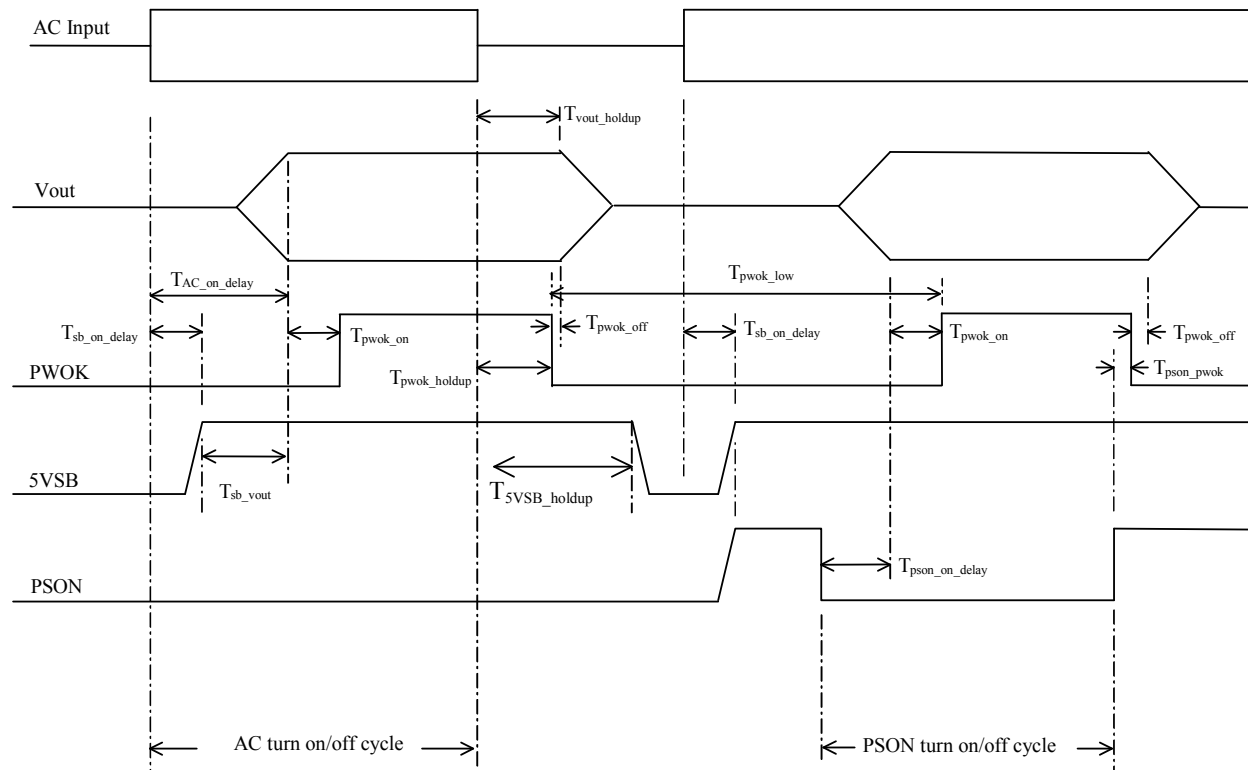

Figure 28. Turn On/Off Timing (Power Supply Signals)

8.4.9 Residual Voltage Immunity in Standby Mode

The power supply should be immune to any residual voltage placed on its outputs (typically, a leakage voltage through the system from standby output) up to 500 mV. There shall be no additional heat generated or stressing of any internal components with this voltage applied to any individual output and all outputs simultaneously. It also should not trip the power supply protection circuits during turn on.

Residual voltage at the power supply outputs for a no load condition shall not exceed 100 mV when AC voltage is applied and the PSON# signal is de-asserted.

9. Regulatory and Certification Information

To help ensure EMC compliance with your local regional rules and regulations, before computer integration, make sure that the chassis, power supply, and other modules have passed EMC testing using a workstation board with a microprocessor from the same family (or higher) and operating at the same (or higher) speed as the microprocessor used on this workstation board. The final configuration of your end system product may require additional EMC compliance testing. For more information please contact your local Intel Representative.

This is an FCC Class A device. Integration of it into a Class B chassis does not result in a Class B device.

9.1 Product Regulatory Compliance

Intended Application – This product was evaluated as Information Technology Equipment (ITE), which may be installed in offices, schools, computer rooms, and similar commercial type locations. The suitability of this product for other product categories and environments (such as: medical, industrial, telecommunications, NEBS, residential, alarm systems, test equipment, etc.), other than an ITE application, may require further evaluation.

9.1.1 Product Safety Compliance

- UL60950 – CSA 60950(USA/Canada)
- EN60950 (Europe)
- IEC60950 (International)
- CB Certificate & Report, IEC60950 (report to include all country national deviations)
- GOST R 50377-92 – Listed on one System License (Russia)
- Belarus License – Listed on System License (Belarus)
- CE - Low Voltage Directive 73/23/EEE (Europe)
- IRAM Certification (Argentina)

9.1.2 Product EMC Compliance - Class A Compliance





- FCC /ICES-003 - Emissions (USA/Canada) Verification
- CISPR 22 – Emissions (International)
- EN55022 - Emissions (Europe)
- EN55024 - Immunity (Europe)
- CE – EMC Directive 89/336/EEC (Europe)
- VCCI Emissions (Japan)
- AS/NZS 3548 Emissions (Australia/New Zealand)
- BSMI CNS13438 Emissions (Taiwan)
- Belarus License – Listed on one System License (Belarus)
- RRL MIC Notice No. 1997-41 (EMC) & 1997-42 (EMI) (Korea)

9.1.3 Certifications/Registrations/Declarations

- UL Certification or NRTL (US/Canada)
- CB Certifications (International)
- CE Declaration of Conformity (CENELEC Europe)
- FCC/ICES-003 Class A Attestation (USA/Canada)
- C-Tick Declaration of Conformity (Australia)
- MED Declaration of Conformity (New Zealand)
- BSMI Certification (Taiwan)
- RRL Certification (Korea)
- Ecology Declaration (International)

9.2 Product Regulatory Compliance Markings

The Intel® Server Board bears the following regulatory marks:

Regulatory Compliance	Region	Marking
UL Mark	USA/Canada	
CE Mark	Europe	
EMC Marking (Class A)	Canada	CANADA ICES-003 CLASS A CANADA NMB-003 CLASSE A
BSMI Marking (Class A)	Taiwan	 <div style="border: 1px solid black; padding: 5px; margin-top: 10px;"> <p>警告使用者： 這是甲類的資訊產品，在居住的環境中使用時，可能會造成射頻干擾，在這種情況下，使用者會被要求採取某些適當的對策</p> </div>
C-tick Marking	Australia/New Zealand	
RRL MIC Mark	Korea	 <p>인증번호: CPU</p>
Country of Origin	Exporting Requirements	Made in China (Provided by label, not silkscreen)
Model Designation	Regulatory Identification	<i>Examples (Server Board S5000PSL) for boxed type boards; or Board PB number for non-boxed boards (typically high-end boards)</i>

9.3 Electromagnetic Compatibility Notices

9.3.1 FCC Verification Statement (USA)

This device complies with Part 15 of the FCC Rules. Operation is subject to the following two conditions: (1) This device may not cause harmful interference, and (2) this device must accept any interference received, including interference that may cause undesired operation.

Intel Corporation
5200 N.E. Elam Young Parkway
Hillsboro, OR 97124-6497
Phone: 1-800-628-8686

This equipment has been tested and found to comply with the limits for a Class B digital device, pursuant to Part 15 of the FCC Rules. These limits are designed to provide reasonable protection against harmful interference in a residential installation. This equipment generates, uses, and can radiate radio frequency energy and, if not installed and used in accordance with the instructions, may cause harmful interference to radio communications. However, there is no guarantee that interference will not occur in a particular installation. If this equipment does cause harmful interference to radio or television reception, which can be determined by turning the equipment off and on, the user is encouraged to try to correct the interference by one or more of the following measures:

- Reorient or relocate the receiving antenna.
- Increase the separation between the equipment and the receiver.
- Connect the equipment into an outlet on a circuit different from that to which the receiver is connected.
- Consult the dealer or an experienced radio/TV technician for help.

Any changes or modifications not expressly approved by the grantee of this device could void the user's authority to operate the equipment. The customer is responsible for ensuring compliance of the modified product.

All cables used to connect to peripherals must be shielded and grounded. Operation with cables, connected to peripherals that are not shielded and grounded may result in interference to radio and TV reception.

9.3.2 ICES-003 (Canada)

Cet appareil numérique respecte les limites bruits radioélectriques applicables aux appareils numériques de Classe B prescrites dans la norme sur le matériel brouilleur: "Appareils Numériques", NMB-003 édictée par le Ministre Canadian des Communications.

English translation of the notice above:

This digital apparatus does not exceed the Class B limits for radio noise emissions from digital apparatus set out in the interference-causing equipment standard entitled "Digital Apparatus," ICES-003 of the Canadian Department of Communications.

9.3.3 Europe (CE Declaration of Conformity)

This product has been tested in accordance too, and complies with the Low Voltage Directive (73/23/EEC) and EMC Directive (89/336/EEC). The product has been marked with the CE Mark to illustrate its compliance.

9.3.4 VCCI (Japan)

この装置は、情報処理装置等電波障害自主規制協議会（VCCI）の基準に基づくクラスB情報技術装置です。この装置は、家庭環境で使用することを目的としていますが、この装置がラジオやテレビジョン受信機に近接して使用されると、受信障害を引き起こすことがあります。
取扱説明書に従って正しい取り扱いをして下さい。

English translation of the notice above:

This is a Class B product based on the standard of the Voluntary Control Council for Interference (VCCI) from Information Technology Equipment. If this is used near a radio or television receiver in a domestic environment, it may cause radio interference. Install and use the equipment according to the instruction manual.

9.3.5 BSMI (Taiwan)

The BSMI Certification Marking and EMC warning is located on the outside rear area of the product.

警告使用者：
這是甲類的資訊產品，在居住的環境中使用時，可能會造成射頻干擾，在這種情況下，使用者會被要求採取某些適當的對策

9.3.6 RRL (Korea)

Following is the RRL certification information for Korea.



1. 기기의 명칭(모델명) :
2. 인증번호 :
3. 인증받은 자의 상호 :
4. 제조년월일 :
5. 제조자/제조국가 :

English translation of the notice above:

1. Type of Equipment (Model Name): On License and Product
2. Certification No.: On RRL certificate. Obtain certificate from local Intel representative
3. Name of Certification Recipient: Intel Corporation
4. Date of Manufacturer: Refer to date code on product
5. Manufacturer/Nation: Intel Corporation/Refer to country of origin marked on product

9.4 Restriction of Hazardous Substances (RoHS) Compliance

Intel has a system in place to restrict the use of banned substances in accordance with the European Directive 2002/95/EC. Compliance is based on declaration that materials banned in the RoHS Directive are either (1) below all applicable substance threshold limits or (2) an approved/pending RoHS exemption applies.

Note: RoHS implementation details are not fully defined and may change.

Threshold limits and banned substances are noted below.

- Quantity limit of 0.1% by mass (1000 PPM) for:
 - Lead
 - Mercury
 - Hexavalent Chromium
 - Polybrominated Biphenyls Diphenyl Ethers (PBDE)
- Quantity limit of 0.01% by mass (100 PPM) for:
 - Cadmium

Appendix A: Integration and Usage Tips

- When adding or removing components or peripherals from the workstation board, you must remove AC power. With AC power plugged into the workstation board, 5-volt standby is still present even though the workstation board is powered off.
- You must install processors in order. CPU 1 is located near the edge of the workstation board and must be populated to operate the board.
- On the back edge of the workstation board are four diagnostic LEDs that display a sequence of red, green, or amber POST codes during the boot process. If the workstation board hangs during POST, the LEDs display the last POST event run before the hang.
- This workstation board supports only Fully Buffered DIMMs (FBDIMMs). For a list of supported memory for this workstation board, see the *Intel® S5000PSL, S5000XSL, S5000XVN, and Server System SC5400RA Tested Memory List*.
- For a list of Intel supported operating systems, add-in cards, and peripherals for this workstation board, see the *Intel® S5000PSL, S5000XSL, S5000XVN, and Server System SC5400RA Tested Hardware and OS List*.
- For a list of Intel supported hard disk drives for this workstation board, see the *Intel® Server Board/Systems Tested Hard Drive List*.
- This workstation board supports only Intel® Xeon® processors 5000 sequence with system bus speeds of 667, 1066, or 1333 MHz. This workstation board does not support previous generation Intel® Xeon® processors.
- For the best performance, you should balance the number of FBDIMMs installed across both memory branches. For example: a four-DIMM configuration performs better than a two DIMM configuration. In a four-DIMM configuration, FBDIMMs should be installed in DIMM sockets A1, B1, C1, and D1. An eight-DIMM configuration performs better than a six-DIMM configuration.
- Removing AC power before performing the CMOS Clear operation causes the system to automatically power up and immediately power down after the CMOS Clear procedure is followed and AC power is re-applied. If this happens, remove the AC power cord, wait 30 seconds, and then re-connect the AC power cord. Power up the system and proceed to the <F2> BIOS Setup Utility to reset the required settings.
- Normal BMC functionality is disabled with the force BMC update jumper set to the “enabled” position (pins 2-3). You should never run the workstation with the BMC force update jumper set in this position and should only use when the standard firmware update process fails. This jumper should remain in the default (disabled) position (pins 1-2) when the workstation is running normally.
- When performing a BIOS update procedure, the BIOS select jumper must be set to its default position (pins 2-3).

Appendix B: BMC Sensor Tables

This appendix lists the sensor identification numbers and information about the sensor type, name, supported thresholds, assertion and de-assertion information, and a brief description of the sensor purpose. See the *Intelligent Platform Management Interface Specification, Version 1.5*, for sensor and event/reading-type table information.

- **Sensor Type**

The Sensor Type is the values enumerated in the *Sensor Type Codes* table in the IPMI specification. The Sensor Type provides the context in which to interpret the sensor, such as the physical entity or characteristic that is represented by this sensor.

- **Event/Reading Type**

The Event/Reading Type values are from the *Event/Reading Type Code Ranges* and *Generic Event/Reading Type Codes* tables in the IPMI specification. Digital sensors are a specific type of discrete sensor, which have only two states.

- **Event Offset/Triggers**

Event Thresholds are event-generating thresholds for threshold types of sensors.

- [u,l][nr,c,nc]: upper nonrecoverable, upper critical, upper noncritical, lower nonrecoverable, lower critical, lower noncritical
- uc, lc: upper critical, lower critical

Event Triggers are supported event-generating offsets for discrete type sensors. The offsets can be found in the *Generic Event/Reading Type Codes* or *Sensor Type Codes* tables in the IPMI specification, depending on whether the sensor event/reading type is generic or a sensor-specific response.

- **Assertion/De-assertion Enables**

Assertion and de-assertion indicators reveal the type of events the sensor generates:

- As: Assertions
- De: De-assertion

- **Readable Value/Offsets**

- Readable Value indicates the type of value returned for threshold and other non-discrete type sensors.
- Readable Offsets indicate the offsets for discrete sensors that are readable with the *Get Sensor Reading* command. Unless otherwise indicated, all event triggers are readable; Readable Offsets consist of the reading type offsets that do not generate events.

- **Event Data**

Event data is the data that is included in an event message generated by the sensor. For threshold-based sensors, the following abbreviations are used:

- R: Reading value
- T: Threshold value

- **Rearm Sensors**

The rearm is a request for the event status for a sensor to be rechecked and updated upon a transition between good and bad states. Rearming the sensors can be done manually or automatically. This column indicates the type supported by the sensor. The following abbreviations are used in the comment column to describe a sensor:

- A: Auto-rearm
- M: Manual rearm

- **Default Hysteresis**

The hysteresis setting applies to all thresholds of the sensor. This column provides the count of hysteresis for the sensor, which can be 1 or 2 (positive or negative hysteresis).

- **Criticality**

Criticality is a classification of the severity and nature of the condition. It also controls the behavior of the Control Panel Status LED

- **Standby**

Some sensors operate on standby power. These sensors may be accessed and/or generate events when the main (system) power is off, but AC power is present.

Table 45. BMC Sensors

Sensor Name	Sensor Number	System Applicability	Sensor Type	Event/Reading Type	Event Offset Triggers	Criticality	Assert/De-assert	Readable Value/Offsets	Event Data	Rearm	Standby
Power Unit Status	01h	All	Power Unit 09h	Sensor Specific 6Fh	Power down	OK	As	-	Trig Offset	A	X
					Power cycle						
					A/C lost						
					Soft power control failure	Crit					
Power unit failure											
Predictive failure	Non-Crit										
Power Unit Redundancy	02h	Chassis-specific	Power Unit 09h	Generic 0Bh	Redundancy regained	OK	As	-	Trig Offset	A	X
					Non-red: suff res from redund						
					Redundancy lost	Degraded					
					Redundancy degraded						
					Non-red: suff from insuff	OK					
Non-red: insufficient	Critical										
Redun degrade from full	OK										
Redun degrade from non-redundant											
Watchdog	03h	All	Watchdog 2 23h	Sensor Specific 6Fh	Timer expired, status only Hard reset Power down Power cycle Timer interrupt	OK	As	-	Trig Offset	A	X

Sensor Name	Sensor Number	System Applicability	Sensor Type	Event/Reading Type	Event Offset Triggers	Criticality	Assert/De-assert	Readable Value/Offsets	Event Data	Rearm	Standby
Platform Security Violation	04h	All	Platform Security Violation Attempt 06h	Sensor Specific 6Fh	Secure mode violation attempt Out-of-band access password violation	OK	As	–	Trig Offset	A	X
Physical Security	05h	Chassis Intrusion is chassis-specific	Physical Security 05h	Sensor Specific 6Fh	Chassis intrusion LAN leash lost 1	OK	As and De	–	Trig Offset	A	X
FP Diag Interrupt (NMI)	07h	All	Critical Interrupt 13h	Sensor Specific 6Fh	Front panel NMI/diagnostic interrupt Bus uncorrectable error	OK	As	–	Trig Offset	A	–
System Event Log	09h	All	Event Logging Disabled 10h	Sensor Specific 6Fh	Log area reset/cleared	OK	As	–	Trig Offset	A	X
Session Audit	0Ah	All	Session Audit 2Ah	Sensor Specific 6Fh	00h – Session activation 01h – Session deactivation	OK	As	–	As defined by IPMI	A	X
System Event ('System Event')	0Bh	All	System Event 12h	Sensor Specific 6Fh	00 – System reconfigured 04 – PEF action	OK	As	–	Trig Offset	A	X
BB +1.2V Vt	10h	All	Voltage 02h	Threshold 01h	[u,l] [c,nc]	Threshold defined	As and De	Analog	R, T	A	–
BB+1.9V NIC Core	11h	All	Voltage 02h	Threshold 01h	[u,l] [c,nc]	Threshold defined	As and De	Analog	R, T	A	X
BB +1.5V AUX	12h	All	Voltage 02h	Threshold 01h	[u,l] [c,nc]	Threshold defined	As and De	Analog	R, T	A	–
BB +1.5V	13h	All	Voltage 02h	Threshold 01h	[u,l] [c,nc]	Threshold defined	As and De	Analog	R, T	A	–
BB +1.8V	14h	All	Voltage 02h	Threshold 01h	[u,l] [c,nc]	Threshold defined	As and De	Analog	R, T	A	–

Sensor Name	Sensor Number	System Applicability	Sensor Type	Event/Reading Type	Event Offset Triggers	Criticality	Assert/De-assert	Readable Value/Offsets	Event Data	Rearm	Standby
BB +3.3V	15h	All	Voltage 02h	Threshold 01h	[u,l] [c,nc]	Threshold defined	As and De	Analog	R, T	A	–
BB +3.3V STB	16h	All	Voltage 02h	Threshold 01h	[u,l] [c,nc]	Threshold defined	As and De	Analog	R, T	A	X
BB +1.5V ESB	17h	All	Voltage 02h	Threshold 01h	[u,l] [c,nc]	Threshold defined	As and De	Analog	R, T	A	X
BB +5V	18h	All	Voltage 02h	Threshold 01h	[u,l] [c,nc]	Threshold defined	As and De	Analog	R, T	A	–
BB +1.2V NIC	19h	All	Voltage 02h	Threshold 01h	[u,l] [c,nc]	Threshold defined	As and De	Analog	R, T	A	–
BB +12V AUX	1Ah	All	Voltage 02h	Threshold 01h	[u,l] [c,nc]	Threshold defined	As and De	Analog	R, T	A	–
BB 0.9V	1Bh	All	Voltage 02h	Threshold 01h	[u,l] [c,nc]	Threshold defined	As and De	Analog	R, T	A	–
BB Vbat	1Eh	All	Voltage 02h	Digital Discrete 05h	01h – Limit exceeded	Critical	As and De	–	R, T	A	X
BB Temp	30h	All	Temperature 01h	Threshold 01h	[u,l] [c,nc]	Threshold defined	As and De	Analog	R, T	A	X
Front Panel Temp	32h	All	Temperature 01h	Threshold 01h	[u,l] [c,nc]	Threshold defined	As and De	Analog	R, T	A	X
BNB Temp	33h	All	Temperature 01h	Threshold 01h	[u,l] [c,nc]	Threshold defined	As and De	Analog	R, T	A	–
CPU 1 FAN	50h	Chassis-specific	Fan 04h	Threshold 01h	[l] [c,nc]	Threshold defined	As and De	Analog	R, T	M	–
CPU 2 FAN	51h	Chassis-specific	Fan 04h	Threshold 01h	[l] [c,nc]	Threshold defined	As and De	Analog	R, T	M	–
SYS FAN 1 TACH	52h	Chassis-specific	Fan 04h	Threshold 01h	[l] [c,nc]	Threshold defined	As and De	Analog	R, T	M	–

Sensor Name	Sensor Number	System Applicability	Sensor Type	Event/Reading Type	Event Offset Triggers	Criticality	Assert/De-assert	Readable Value/Offsets	Event Data	Rearm	Standby
SYS FAN 2 TACH	53h	Chassis-specific	Fan 04h	Threshold 01h	[!] [c,nc]	Threshold defined	As and De	Analog	R, T	M	–
SYS FAN 3 TACH'	54h	Chassis-specific	Fan 04h	Threshold 01h	[!] [c,nc]	Threshold defined	As and De	Analog	R, T	M	–
SYS FAN 4 TACH	55h	Chassis-specific	Fan 04h	Threshold 01h	[!] [c,nc]	Threshold defined	As and De	Analog	R, T	M	–
SYS FAN 5 TACH'	56h	Chassis-specific	Fan 04h	Threshold 01h	[!] [c,nc]	Threshold defined	As and De	Analog	R, T	M	–
SYS FAN 6 TACH	57h	Chassis-specific	Fan 04h	Threshold 01h	[!] [c,nc]	Threshold defined	As and De	Analog	R, T	M	–
Tach Fan (Not used on this server)	58h	Chassis-specific	Fan 04h	Threshold 01h	[!] [c,nc]	Threshold defined	As and De	Analog	R, T	M	–
Tach Fan (Not used on this server)	59h	Chassis-specific	Fan 04h	Threshold 01h	[!] [c,nc]	Threshold defined	As and De	Analog	R, T	M	–
Fan 1 Present	60h	Chassis-specific	Fan 04h	Generic 08h	Device present	OK	As and De	–	T	A	–
Fan 2 Present	61h	Chassis-specific	Fan 04h	Generic 08h	Device present	OK	As and De	–	T	A	–
Fan 3 Present	62h	Chassis-specific	Fan 04h	Generic 08h	Device present	OK	As and De	–	T	A	–
Fan 4 Present	63h	Chassis-specific	Fan 04h	Generic 08h	Device present	OK	As and De	–	T	A	–
Fan 5 Present	64h	Chassis-specific	Fan 04h	Generic 08h	Device present	OK	As and De	–	T	A	–
Fan 6 Present	65h	Chassis-specific	Fan 04h	Generic 08h	Device present	OK	As and De	–	T	A	–
Fan 7 Present	66h	Chassis-specific	Fan 04h	Generic 08h	Device present	OK	As and De	–	T	A	–

Sensor Name	Sensor Number	System Applicability	Sensor Type	Event/Reading Type	Event Offset Triggers	Criticality	Assert/De-assert	Readable Value/Offsets	Event Data	Rearm	Standby
Fan 8 Present	67h	Chassis-specific	Fan 04h	Generic 08h	Device present	OK	As and De	–	T	A	–
Fan 9 Present	68h	Chassis-specific	Fan 04h	Generic 08h	Device present	OK	As and De	–	T	A	–
Fan 10 Present	69h	Chassis-specific	Fan 04h	Generic 08h	Device present	OK	As and De	–	T	A	–
Fan Redundancy	6Fh	Chassis-specific	Fan 04h	Generic 0Bh	Redundancy regained	OK	As	–	Trig Offset	A	X
					Redundancy lost Redundancy degraded	Degraded					
					Non-red: suff res from redund Non-red: suff from insuff	OK					
					Non-red: insufficient	Critical					
					Redun degrade from full Redun degrade from non-redundant	OK					
Power Supply Status 1	70h	Chassis-specific	Power Supply 08h	Sensor Specific 6Fh	Presence	OK	As and De	–	Trig Offset	A	X
					Failure	Critical					
					Predictive fail	Non-Crit					
					A/C lost	Critical					
					Configuration error	Non-Crit					
Power Supply Status 2	71h	Chassis-specific	Power Supply 08h	Sensor Specific 6Fh	Presence	OK	As and De	–	Trig Offset	A	X
					Failure	Critical					
					Predictive fail	Non-Crit					
					A/C lost	Critical					
					Configuration error	Non-Crit					

Sensor Name	Sensor Number	System Applicability	Sensor Type	Event/Reading Type	Event Offset Triggers	Criticality	Assert/De-assert	Readable Value/Offsets	Event Data	Rearm	Standby
Power Nozzle Power Supply 1	78h	Chassis-specific	Current 03h	Threshold 01h	[u] [c,nc]	Threshold defined	As and De	Analog	R, T	A	–
Power Nozzle Power Supply 2	79h	Chassis-specific	Current 03h	Threshold 01h	[u] [c,nc]	Threshold defined	As and De	Analog	R, T	A	–
Power Gauge V1 rail (+12v) Power Supply 1	7Ah	Chassis-specific	Current 03h	Threshold 01h	[u] [c,nc]	Threshold defined	As and De	Analog	R, T	A	–
Power Gauge V1 rail (+12v) Power Supply 2	7Bh	Chassis-specific	Current 03h	Threshold 01h	[u] [c,nc]	Threshold defined	As and De	Analog	R, T	A	–
Power Gauge (aggregate power) Power Supply 1	7Ch	Chassis-specific	Other Units 0Bh	Threshold 01h	[u] [c,nc]	Threshold defined	As and De	Analog	R, T	A	–
Power Gauge (aggregate power) Power Supply 2	7Dh	Chassis-specific	Other Units 0Bh	Threshold 01h	[u] [c,nc]	Threshold defined	As and De	Analog	R, T	A	–

Sensor Name	Sensor Number	System Applicability	Sensor Type	Event/Reading Type	Event Offset Triggers	Criticality	Assert/De-assert	Readable Value/Offsets	Event Data	Rearm	Standby
System ACPI Power State	82h	All	System ACPI Power State 22h	Sensor Specific 6Fh	S0/G0 S1 S3 S4 S5/G2 G3 mechanical off	OK	As	–	Trig Offset	A	X
Button	84h	All	Button 14h	Sensor Specific 6Fh	Power button Reset button	OK	As	–	Trig Offset	A	X
SMI Timeout	85h	All	SMI Timeout F3h	Digital Discrete 03h	01h – State asserted	Critical	As and De	–	Trig Offset	A	–
Sensor Failure	86h	All	Sensor Failure F6h	OEM Sensor Specific 73h	I ² C device not found I ² C device error detected I ² C bus timeout	OK	As	–	Trig Offset	A	X
NMI Signal State	87h	All	OEM C0h	Digital Discrete 03h	01h – State asserted	OK	–	01h	–	–	–
SMI Signal State	88h	All	OEM C0h	Digital Discrete 03h	01h – State asserted	OK	–	01h	–	–	–
Proc 1 Status	90h	All	Processor 07h	Sensor Specific 6Fh	IERR	Critical	As and De	–	Trig Offset	M	X
					Thermal trip	Non-rec					
					Config error	Critical					
					Presence	OK					
					Disabled	Degraded					
Proc 2 Status	91h	All	Processor 07h	Sensor Specific 6Fh	IERR	Critical	As and De	–	Trig Offset	M	X
					Thermal trip	Non-rec					
					Config error	Critical					
					Presence	OK					
					Disabled	Degraded					

Sensor Name	Sensor Number	System Applicability	Sensor Type	Event/Reading Type	Event Offset Triggers	Criticality	Assert/De-assert	Readable Value/Offsets	Event Data	Rearm	Standby
Proc 1 Temp	98h	All	Temperature	Threshold 01h	[u,l] [c,nc]	Threshold defined	As and De	Analog	R, T	A	–
Proc 2 Temp	9Ah	All	Temperature	Threshold 01h	[u,l] [c,nc]	Threshold defined	As and De	Analog	R, T	A	–
PCIe Link0	A0h	Critical Interrupt 13F	Sensor Specific 6Fh	PCIe Link0	Bus correctable error	OK	As	–	See the BIOS EPS	A	–
					Bus uncorrectable error	Degraded					
PCIe Link1	A1h	Critical Interrupt 13F	Sensor Specific 6Fh	PCIe Link1	Bus correctable error	OK	As	–	See the BIOS EPS	A	–
					Bus uncorrectable error	Degraded					
PCIe Link2	A2h	Critical Interrupt 13F	Sensor Specific 6Fh	PCIe Link2	Bus correctable error	OK	As	–	See the BIOS EPS	A	–
					Bus uncorrectable error	Degraded					
PCIe Link3	A3h	Critical Interrupt 13F	Sensor Specific 6Fh	PCIe Link3	Bus correctable error	OK	As	–	See the BIOS EPS	A	–
					Bus uncorrectable error	Degraded					
PCIe Link4	A4h	Critical Interrupt 13F	Sensor Specific 6Fh	PCIe Link4	Bus correctable error	OK	As	–	See the BIOS EPS	A	–
					Bus uncorrectable error	Degraded					
PCIe Link5	A5h	Critical Interrupt 13F	Sensor Specific 6Fh	PCIe Link5	Bus correctable error	OK	As	–	See the BIOS EPS	A	–
					Bus uncorrectable error	Degraded					
PCIe Link6	A6h	Critical Interrupt 13F	Sensor Specific 6Fh	PCIe Link6	Bus correctable error	OK	As	–	See the BIOS EPS	A	–
					Bus uncorrectable error	Degraded					

Sensor Name	Sensor Number	System Applicability	Sensor Type	Event/Reading Type	Event Offset Triggers	Criticality	Assert/De-assert	Readable Value/Offsets	Event Data	Rearm	Standby
PCIe Link7	A7h	Critical Interrupt 13F	Sensor Specific 6Fh	PCIe Link7	Bus correctable error	OK	As	-	See the BIOS EPS	A	-
					Bus uncorrectable error	Degraded					
PCIe Link8	A8h	Critical Interrupt 13F	Sensor Specific 6Fh	PCIe Link8	Bus correctable error	OK	As	-	See the BIOS EPS	A	-
					Bus uncorrectable error	Degraded					
PCIe Link9	A9h	Critical Interrupt 13F	Sensor Specific 6Fh	PCIe Link9	Bus correctable error	OK	As	-	See the BIOS EPS	A	-
					Bus uncorrectable error	Degraded					
PCIe Link10	AAh	Critical Interrupt 13F	Sensor Specific 6Fh	PCIe Link10	Bus correctable error	OK	As	-	See the BIOS EPS	A	-
					Bus uncorrectable error	Degraded					
PCIe Link11	ABh	Critical Interrupt 13F	Sensor Specific 6Fh	PCIe Link11	Bus correctable error	OK	As	-	See the BIOS EPS	A	-
					Bus uncorrectable error	Degraded					
PCIe Link12	ACh	Critical Interrupt 13F	Sensor Specific 6Fh	PCIe Link12	Bus correctable error	OK	As	-	See the BIOS EPS	A	-
					Bus uncorrectable error	Degraded					
PCIe Link13	ADh	Critical Interrupt 13F	Sensor Specific 6Fh	PCIe Link13	Bus correctable error	OK	As	-	See the BIOS EPS	A	-
					Bus uncorrectable error	Degraded					
Proc 1 Thermal Control	C0h	All	Temperature 01h	Threshold 01h	[u] [c,nc]	Threshold defined	As and De	Analog	Trig Offset	M	-
Proc 2 Thermal Control	C1h	All	Temperature 01h	Threshold 01h	[u] [c,nc]	Threshold defined	As and De	Analog	Trig Offset	M	-

Sensor Name	Sensor Number	System Applicability	Sensor Type	Event/Reading Type	Event Offset Triggers	Criticality	Assert/De-assert	Readable Value/Offsets	Event Data	Rearm	Standby
Proc 1 VRD Over Temp	C8h	All	Temperature 01h	Digital Discrete 05h	01h – Limit exceeded	Non-Critical	As and De	–	Trig Offset	M	–
Proc 2 VRD Over Temp	C9h	All	Temperature 01h	Digital Discrete 05h	01h – Limit exceeded	Non-Critical	As and De	–	Trig Offset	M	–
Proc 1 Vcc	D0h	All	Voltage 02h	Threshold 01h	[u,l] [c,nc]	Threshold defined	As and De	Analog	R, T	A	–
Proc 2 Vcc	D1h	All	Voltage 02h	Threshold 01h	[u,l] [c,nc]	Threshold defined	As and De	Analog	R, T	A	–
Proc 1 Vcc Out-of-Range	D2h	All	Voltage 02h	Digital Discrete 05h	01h – Limit exceeded	Non-Critical	As and De	Discrete	R, T	A	–
Proc 2 Vcc Out-of-Range	D3h	All	Voltage 02h	Digital Discrete 05h	01h – Limit exceeded	Non-Critical	As and De	Discrete	R, T	A	–
CPU Population Error	D8h	All	Processor 07h	Generic 03h	01h – State asserted	Critical	As and De	–	R, T	A	–
DIMM A1	E0h	All	Slot Connector 21h	Sensor Specific 6Fh	Fault status asserted	Degraded	As	–	Trig Offset	A	–
					Device installed	OK					
					Disabled	Degraded					
					Sparing	OK					
DIMM A2	E1h	All	Slot Connector 21h	Sensor Specific 6Fh	Fault status asserted	Degraded	As	–	Trig Offset	A	–
					Device installed	OK					
					Disabled	Degraded					
					Sparing	OK					
DIMM B1	E2h	All	Slot Connector 21h	Sensor Specific 6Fh	Fault status asserted	Degraded	As	–	Trig Offset	A	–
					Device installed	OK					
					Disabled	Degraded					

Sensor Name	Sensor Number	System Applicability	Sensor Type	Event/Reading Type	Event Offset Triggers	Criticality	Assert/De-assert	Readable Value/Offsets	Event Data	Rearm	Standby
					Sparing	OK					
DIMM B2	E3h	All	Slot Connector 21h	Sensor Specific 6Fh	Fault status asserted	Degraded	As	-	Trig Offset	A	-
					Device installed	OK					
					Disabled	Degraded					
					Sparing	OK					
DIMM C1	E4h	All	Slot Connector 21h	Sensor Specific 6Fh	Fault status asserted	Degraded	As	-	Trig Offset	A	-
					Device installed	OK					
					Disabled	Degraded					
					Sparing	OK					
DIMM C2	E5h	All	Slot Connector 21h	Sensor Specific 6Fh	Fault status asserted	Degraded	As	-	Trig Offset	A	-
					Device installed	OK					
					Disabled	Degraded					
					Sparing	OK					
DIMM D1	E6h	All	Slot Connector 21h	Sensor Specific 6Fh	Fault status asserted	Degraded	As	-	Trig Offset	A	-
					Device installed	OK					
					Disabled	Degraded					
					Sparing	OK					
DIMM D2	E7h	All	Slot Connector 21h	Sensor Specific 6Fh	Fault status asserted	Degraded	As	-	Trig Offset	A	-
					Device installed	OK					
					Disabled	Degraded					
					Sparing	OK					
Memory A Error	ECh	All	Memory 0Ch	Sensor Specific 6Fh	Correctable ECC Uncorrectable ECC	OK	As	-	Trig Offset	A	-
Memory B Error	EDh	System-specific	Memory 0Ch	Sensor Specific 6Fh	Correctable ECC Uncorrectable ECC	OK	As	-	Trig Offset	A	-

Sensor Name	Sensor Number	System Applicability	Sensor Type	Event/Reading Type	Event Offset Triggers	Criticality	Assert/De-assert	Readable Value/Offsets	Event Data	Rearm	Standby
Memory C Error	EEh	System-specific	Memory 0Ch	Sensor Specific 6Fh	Correctable ECC Uncorrectable ECC	OK	As	–	Trig Offset	A	–
Memory D Error	EFh	System-specific	Memory 0Ch	Sensor Specific 6Fh	Correctable ECC Uncorrectable ECC	OK	As	–	Trig Offset	A	–
B0 DIMM Sparing Enabled	F0h	All	Entity Presence 25h	Sensor Specific 6Fh	Entity present	OK	As	–	Trig Offset	A	–
B0 DIMM Sparing Redundancy	F1h	All	Memory 0Ch	Discrete 0Bh	Fully redundant	OK	As	–	Trig Offset	A	–
					Non-red: suff res from redund	Degraded					
					Non-red: suff res from insuff res	Critical					
B1 DIMM Sparing Enabled	F2h	All	Entity Presence 25h	Sensor Specific 6Fh	Entity present	OK	As	–	Trig Offset	A	–
B1 DIMM Sparing Redundancy	F3h	All	Memory 0Ch	Discrete 0Bh	Fully redundant	OK	As	–	Trig Offset	A	–
					Non-red: suff res from redund	Degraded					
					Non-red: suff res from insuff res	Critical					
B01 DIMM Mirroring Enabled	F4h	All	Entity Presence 25h	Sensor Specific 6Fh	Entity present	OK	As	–	Trig Offset	A	–
B01 DIMM Mirroring Redundancy	F5h	All	Memory 0Ch	Discrete 0Bh	Fully redundant	OK	As	–	Trig Offset	A	–
					Non-red:suff res from redund Non-red:suff res from insuff res	Degraded					

Sensor Name	Sensor Number	System Applicability	Sensor Type	Event/Reading Type	Event Offset Triggers	Criticality	Assert/De-assert	Readable Value/Offsets	Event Data	Rearm	Standby
					Non-red: insuff res	Critical					

Note 1: Not supported except for ESB2 embedded NICs.

Appendix C: POST Code Diagnostic LED Decoder

During the system boot process, the BIOS executes a number of platform configuration processes, each of which is assigned a specific hex POST code number. As each configuration routine is started, the BIOS displays the POST code to the POST Code Diagnostic LEDs on the back edge of the workstation board. To assist in troubleshooting a system hang during the POST process, you can use the Diagnostic LEDs to identify the last POST process executed.

Each POST code is represented by a combination of colors from the four LEDs. The LEDs are capable of displaying three colors: green, red, and amber. The POST codes are divided into two nibbles, an upper nibble and a lower nibble. Each bit in the upper nibble is represented by a red LED and each bit in the lower nibble is represented by a green LED. If both bits are set in the upper and lower nibbles, then both red and green LEDs are lit, resulting in an amber color. If both bits are clear, then the LED is off.

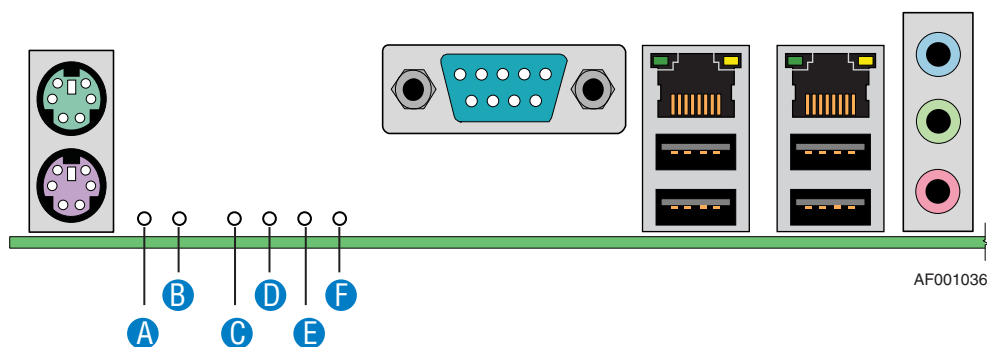

A. Status LED	D. Bit 2 LED (POST LED)
B. ID LED	E. Bit 1 LED (POST LED)
C. MSB LED (POST LED)	F. LSB LED (POST LED)

Figure 29. Diagnostic LED Placement Diagram

In the following example, the BIOS sends a value of ACh to the diagnostic LED decoder. The LEDs are decoded as follows:

- Red bits = 1010b = Ah
- Green bits = 1100b = Ch

Since the red bits correspond to the upper nibble and the green bits correspond to the lower nibble, the two are concatenated as ACh.

Table 46. POST Progress Code LED Example

LEDs	8h		4h		2h		1h	
	Red	Green	Red	Green	Red	Green	Red	Green
ACh	1	1	0	1	1	0	0	0
Result	Amber		Green		Red		Off	
	MSB		Bit 2		Bit 1		LSB	

Table 47. Diagnostic LED POST Code Decoder

Checkpoint	Diagnostic LED Decoder				Description
	G=Green, R=Red, A=Amber				
	MSB	Bit 2	Bit 1	LSB	
Host Processor					
0x10h	Off	Off	Off	R	Power-on initialization of the host processor (bootstrap processor)
0x11h	Off	Off	Off	A	Host processor cache initialization (including AP)
0x12h	Off	Off	G	R	Starting application processor initialization
0x13h	Off	Off	G	A	SMM initialization
Chipset					
0x21h	Off	Off	R	G	Initializing a chipset component
Memory					
0x22h	Off	Off	A	Off	Reading configuration data from memory (SPD on DIMM)
0x23h	Off	Off	A	G	Detecting presence of memory
0x24h	Off	G	R	Off	Programming timing parameters in the memory controller
0x25h	Off	G	R	G	Configuring memory parameters in the memory controller
0x26h	Off	G	A	Off	Optimizing memory controller settings
0x27h	Off	G	A	G	Initializing memory, such as ECC init
0x28h	G	Off	R	Off	Testing memory
PCI Bus					
0x50h	Off	R	Off	R	Enumerating PCI buses
0x51h	Off	R	Off	A	Allocating resources to PCI buses
0x52h	Off	R	G	R	Hot Plug PCI controller initialization
0x53h	Off	R	G	A	Reserved for PCI bus
0x54h	Off	A	Off	R	Reserved for PCI bus
0x55h	Off	A	Off	A	Reserved for PCI bus
0x56h	Off	A	G	R	Reserved for PCI bus
0x57h	Off	A	G	A	Reserved for PCI bus
USB					
0x58h	G	R	Off	R	Resetting USB bus
0x59h	G	R	Off	A	Reserved for USB devices
ATA/ATAPI/SATA					
0x5Ah	G	R	G	R	Resetting PATA/SATA bus and all devices
0x5Bh	G	R	G	A	Reserved for ATA
SMBUS					
0x5Ch	G	A	Off	R	Resetting SMBUS
0x5Dh	G	A	Off	A	Reserved for SMBUS
Local Console					
0x70h	Off	R	R	R	Resetting the video controller (VGA)
0x71h	Off	R	R	A	Disabling the video controller (VGA)
0x72h	Off	R	A	R	Enabling the video controller (VGA)
Remote Console					
0x78h	G	R	R	R	Resetting the console controller
0x79h	G	R	R	A	Disabling the console controller

Checkpoint	Diagnostic LED Decoder				Description
	G=Green, R=Red, A=Amber				
	MSB	Bit 2	Bit 1	LSB	
0x7Ah	G	R	A	R	Enabling the console controller
Keyboard (PS2 or USB)					
0x90h	R	Off	Off	R	Resetting the keyboard
0x91h	R	Off	Off	A	Disabling the keyboard
0x92h	R	Off	G	R	Detecting the presence of the keyboard
0x93h	R	Off	G	A	Enabling the keyboard
0x94h	R	G	Off	R	Clearing keyboard input buffer
0x95h	R	G	Off	A	Instructing keyboard controller to run Self Test (PS2 only)
Mouse (PS2 or USB)					
0x98h	A	Off	Off	R	Resetting the mouse
0x99h	A	Off	Off	A	Detecting the mouse
0x9Ah	A	Off	G	R	Detecting the presence of mouse
0x9Bh	A	Off	G	A	Enabling the mouse
Fixed Media					
0xB0h	R	Off	R	R	Resetting fixed media device
0xB1h	R	Off	R	A	Disabling fixed media device
0xB2h	R	Off	A	R	Detecting presence of a fixed media device (IDE hard drive detection, and so forth)
0xB3h	R	Off	A	A	Enabling/configuring a fixed media device
Removable Media					
0xB8h	A	Off	R	R	Resetting removable media device
0xB9h	A	Off	R	A	Disabling removable media device
0xBAh	A	Off	A	R	Detecting presence of a removable media device (IDE CD-ROM detection, and so forth)
0xBCh	A	G	R	R	Enabling/configuring a removable media device
Boot Device Selection					
0xD0	R	R	Off	R	Trying boot device selection
0xD1	R	R	Off	A	Trying boot device selection
0xD2	R	R	G	R	Trying boot device selection
0xD3	R	R	G	A	Trying boot device selection
0xD4	R	A	Off	R	Trying boot device selection
0xD5	R	A	Off	A	Trying boot device selection
0xD6	R	A	G	R	Trying boot device selection
0xD7	R	A	G	A	Trying boot device selection
0xD8	A	R	Off	R	Trying boot device selection
0xD9	A	R	Off	A	Trying boot device selection
0XDA	A	R	G	R	Trying boot device selection
0xDB	A	R	G	A	Trying boot device selection
0xDC	A	A	Off	R	Trying boot device selection
0xDE	A	A	G	R	Trying boot device selection
0xDF	A	A	G	A	Trying boot device selection
Pre-EFI Initialization (PEI) Core					
0xE0h	R	R	R	Off	Started dispatching early initialization modules (PEIM)

Checkpoint	Diagnostic LED Decoder				Description
	G=Green, R=Red, A=Amber				
	MSB	Bit 2	Bit 1	LSB	
0xE2h	R	R	A	Off	Initial memory found, configured, and installed correctly
0xE1h	R	R	R	G	Reserved for initialization module use (PEIM)
0xE3h	R	R	A	G	Reserved for initialization module use (PEIM)
Driver Execution Environment (DXE) Core					
0xE4h	R	A	R	Off	Entered EFI driver execution phase (DXE)
0xE5h	R	A	R	G	Started dispatching drivers
0xE6h	R	A	A	Off	Started connecting drivers
DXE Drivers					
0xE7h	R	A	A	G	Waiting for user input
0xE8h	A	R	R	Off	Checking password
0xE9h	A	R	R	G	Entering BIOS setup
0xEAh	A	R	A	Off	Flash Update
0xEEh	A	A	A	Off	Calling Int 19. One beep unless silent boot is enabled.
0xEFh	A	A	A	G	Unrecoverable boot failure/S3 resume failure
Runtime Phase/EFI Operating System Boot					
0xF4h	R	A	R	R	Entering Sleep state
0xF5h	R	A	R	A	Exiting Sleep state
0xF8h	A	R	R	R	Operating system has requested EFI to close boot services (ExitBootServices () has been called)
0xF9h	A	R	R	A	Operating system has switched to virtual address mode (SetVirtualAddressMap () has been called)
0xFAh	A	R	A	R	Operating system has requested the system to reset (ResetSystem () has been called)
Pre-EFI Initialization Module (PEIM)/Recovery					
0x30h	Off	Off	R	R	Crisis recovery has been initiated because of a user request
0x31h	Off	Off	R	A	Crisis recovery has been initiated by software (corrupt flash)
0x34h	Off	G	R	R	Loading crisis recovery capsule
0x35h	Off	G	R	A	Handing off control to the crisis recovery capsule
0x3Fh	G	G	A	A	Unable to complete crisis recovery.

Appendix D: POST Code Errors

Whenever possible, the BIOS outputs the current boot progress codes on the video screen. Progress codes are 32-bit quantities plus optional data. The 32-bit numbers include class, subclass, and operation information. The class and subclass fields point to the type of hardware being initialized. The operation field represents the specific initialization activity. Based on the data bit availability to display progress codes, you can customize a progress code to fit the data width. The higher the data bit, the higher the granularity of information that can be sent on the progress port. The progress codes may be reported by the system BIOS or option ROMs.

The response column in the following table is divided into two types:

- **Pause:** The message displays in the Error Manager screen, an error is logged to the SEL, and user input is required to continue. The user can take immediate corrective action or choose to continue booting.
- **Halt:** The message displays in the Error Manager screen, an error is logged to the SEL, and the system cannot boot unless the error is resolved. The user must replace the faulty part and restart the system.

Table 48. POST Error Messages and Handling

Error Code	Error Message	Response
004C	Keyboard/interface error	Pause
0012	CMOS date/time not set	Pause
5220	Configuration cleared by jumper	Pause
5221	Passwords cleared by jumper	Pause
5223	Configuration default loaded	Pause
0048	Password check failed	Halt
0141	PCI resource conflict	Pause
0146	Insufficient memory to shadow PCI ROM	Pause
8110	Processor 01 internal error (IERR) on last boot	Pause
8111	Processor 02 internal error (IERR) on last boot	Pause
8120	Processor 01 thermal trip error on last boot	Pause
8121	Processor 02 thermal trip error on last boot	Pause
8130	Processor 01 disabled	Pause
8131	Processor 02 disabled	Pause
8160	Processor 01 unable to apply BIOS update	Pause
8161	Processor 02 unable to apply BIOS update	Pause
8190	Watchdog timer failed on last boot	Pause
8198	Operating system boot watchdog timer expired on last boot	Pause
0192	L3 cache size mismatch	Halt
0194	CPUID, processor family are different	Halt
0195	Front side bus mismatch	Pause
0197	Processor speeds mismatched	Pause
8300	Baseboard management controller failed self-test	Pause
8306	Front panel controller locked	Pause

Error Code	Error Message	Response
8305	Hotswap controller failed	Pause
84F2	Baseboard management controller failed to respond	Pause
84F3	Baseboard management controller in update mode	Pause
84F4	Sensor data record empty	Pause
84FF	System event log full	Pause
8500	Memory Component could not be configured in the selected RAS mode.	Pause
8520	DIMM_A1 failed Self Test (BIST).	Pause
8521	DIMM_A2 failed Self Test (BIST).	Pause
8522	DIMM_A3 failed Self Test (BIST).	Pause
8523	DIMM_A4 failed Self Test (BIST).	Pause
8524	DIMM_B1 failed Self Test (BIST).	Pause
8525	DIMM_B2 failed Self Test (BIST).	Pause
8526	DIMM_B3 failed Self Test (BIST).	Pause
8527	DIMM_B4 failed Self Test (BIST).	Pause
8528	DIMM_C1 failed Self Test (BIST).	Pause
8529	DIMM_C2 failed Self Test (BIST).	Pause
852A	DIMM_C3 failed Self Test (BIST).	Pause
852B	DIMM_C4 failed Self Test (BIST).	Pause
852C	DIMM_D1 failed Self Test (BIST).	Pause
852D	DIMM_D2 failed Self Test (BIST).	Pause
852E	DIMM_D3 failed Self Test (BIST).	Pause
852F	DIMM_D4 failed Self Test (BIST).	Pause
8540	Memory component lost redundancy during the last boot.	Pause
8580	DIMM_A1 correctable ECC error encountered.	Pause
8581	DIMM_A2 correctable ECC error encountered.	Pause
8582	DIMM_A3 correctable ECC error encountered.	Pause
8583	DIMM_A4 correctable ECC error encountered.	Pause
8584	DIMM_B1 correctable ECC error encountered.	Pause
8585	DIMM_B2 correctable ECC error encountered.	Pause
8586	DIMM_B3 correctable ECC error encountered.	Pause
8587	DIMM_B4 correctable ECC error encountered.	Pause
8588	DIMM_C1 correctable ECC error encountered.	Pause
8589	DIMM_C2 correctable ECC error encountered.	Pause
858A	DIMM_C3 correctable ECC error encountered.	Pause
858B	DIMM_C4 correctable ECC error encountered.	Pause
858C	DIMM_D1 correctable ECC error encountered.	Pause
858D	DIMM_D2 correctable ECC error encountered.	Pause
858E	DIMM_D3 correctable ECC error encountered.	Pause
858F	DIMM_D4 correctable ECC error encountered.	Pause
8600	Primary and secondary BIOS IDs do not match.	Pause
8601	Override jumper is set to force boot from lower alternate BIOS bank of flash ROM	Pause
8602	Watchdog timer expired (secondary BIOS may be bad!)	Pause
8603	Secondary BIOS checksum fail	Pause

POST Error Beep Codes

The following table lists POST error beep codes. Prior to system Video initialization, the BIOS uses these beep codes to inform users on error conditions. The beep code is followed by a user-visible code on POST Progress LEDs.

Table 49. POST Error Beep Codes

Beeps	Error Message	POST Progress Code	Description
3	Memory error		System halted because a fatal error related to the memory was detected.
6	BIOS rolling back error		The system has detected a corrupted BIOS in the flash part and is rolling back to the last good BIOS.

The BMC may generate beep codes upon detection of failure conditions. Beep codes are sounded each time the problem is discovered, such as on each power-up attempt, but are not sounded continuously. The following table lists codes common across all Intel® server boards and systems that use the Intel® 5000 chipset. Each digit in the code is represented by a sequence of beeps whose count is equal to the digit.

Table 50. BMC Beep Codes

Code	Reason for Beep	Associated Sensors	Supported?
1-5-2-1	CPU: Empty slot/population error – Processor slot 1 is not populated.	CPU Population Error	Yes
1-5-2-2	CPU: No processors (terminators only)	N/A	No
1-5-2-3	CPU: Configuration error (e.g., VID mismatch)	N/A	No
1-5-2-4	CPU: Configuration error (e.g, BSEL mismatch)	N/A	No
1-5-4-2	Power fault: DC power unexpectedly lost (power good dropout)	Power Unit – power unit failure offset	Yes
1-5-4-3	Chipset control failure	N/A	No
1-5-4-4	Power control fault	Power Unit – soft power control failure offset	Yes

Appendix E: Supported Intel® Server Chassis

The Intel® Workstation Board S5000XVN is supported in the following Intel® pedestal server chassis:

- Intel® Server Chassis SC5400 BASE
- Intel® Entry Server Chassis SC5299-E WS

Glossary

This appendix contains important terms used in the preceding chapters. For ease of use, numeric entries are listed first (for example, “82460GX”) with alpha entries following (for example, “AGP 4x”). Acronyms are then entered in their respective place, with non-acronyms following.

Term	Definition
ACPI	Advanced Configuration and Power Interface
AP	Application Processor
APIC	Advanced Programmable Interrupt Control
ASIC	Application Specific Integrated Circuit
ASMI	Advanced Server Management Interface
BIOS	Basic Input/Output System
BIST	Built-In Self Test
BMC	Baseboard Management Controller
Bridge	Circuitry connecting one computer bus to another, allowing an agent on one to access the other
BSP	Bootstrap Processor
byte	8-bit quantity.
CBC	Chassis Bridge Controller (A microcontroller connected to one or more other CBCs, together they bridge the IPMB buses of multiple chassis.
CEK	Common Enabling Kit
CHAP	Challenge Handshake Authentication Protocol
CMOS	In terms of this specification, this describes the PC-AT compatible region of battery-backed 128 bytes of memory, which normally resides on the server board.
DPC	Direct Platform Control
EEPROM	Electrically Erasable Programmable Read-Only Memory
EHCI	Enhanced Host Controller Interface
EMP	Emergency Management Port
EPS	External Product Specification
ESB2	Enterprise South Bridge 2
FBD	Fully Buffered DIMM
F MB	Flexible Mother Board
FRB	Fault Resilient Booting
FRU	Field Replaceable Unit
FSB	Front Side Bus
GB	1024 MB
GPIO	General Purpose I/O
GTL	Gunning Transceiver Logic
HSC	Hot-Swap Controller
Hz	Hertz (1 cycle/second)
I2C	Inter-Integrated Circuit Bus
IA	Intel® Architecture
IBF	Input Buffer
ICH	I/O Controller Hub
IC MB	Intelligent Chassis Management Bus

Term	Definition
IERR	Internal Error
IFB	I/O and Firmware Bridge
INTR	Interrupt
IP	Internet Protocol
IPMB	Intelligent Platform Management Bus
IPMI	Intelligent Platform Management Interface
IR	Infrared
ITP	In-Target Probe
KB	1024 bytes
KCS	Keyboard Controller Style
LAN	Local Area Network
LCD	Liquid Crystal Display
LED	Light Emitting Diode
LPC	Low Pin Count
LUN	Logical Unit Number
MAC	Media Access Control
MB	1024KB
MCH	Memory Controller Hub
MD2	Message Digest 2 – Hashing Algorithm
MD5	Message Digest 5 – Hashing Algorithm – Higher Security
ms	milliseconds
MTTR	Memory Type Range Register
Mux	Multiplexor
NIC	Network Interface Controller
NMI	Nonmaskable Interrupt
OBF	Output Buffer
OEM	Original Equipment Manufacturer
Ohm	Unit of electrical resistance
PEF	Platform Event Filtering
PEP	Platform Event Paging
PIA	Platform Information Area (This feature configures the firmware for the platform hardware)
PLD	Programmable Logic Device
PMI	Platform Management Interrupt
POST	Power-On Self Test
PSMI	Power Supply Management Interface
PWM	Pulse-Width Modulation
RAM	Random Access Memory
RASUM	Reliability, Availability, Serviceability, Usability, and Manageability
RISC	Reduced Instruction Set Computing
ROM	Read Only Memory
RTC	Real-Time Clock (Component of ICH peripheral chip on the server board)
SDR	Sensor Data Record
SECC	Single Edge Connector Cartridge
SEEPROM	Serial Electrically Erasable Programmable Read-Only Memory

Term	Definition
SEL	System Event Log
SIO	Server Input/Output
SMI	Server Management Interrupt (SMI is the highest priority nonmaskable interrupt)
SMM	Server Management Mode
SMS	Server Management Software
SNMP	Simple Network Management Protocol
TBD	To Be Determined
TIM	Thermal Interface Material
UART	Universal Asynchronous Receiver/Transmitter
UDP	User Datagram Protocol
UHCI	Universal Host Controller Interface
UTC	Universal time coordinare
VID	Voltage Identification
VRD	Voltage Regulator Down
Word	16-bit quantity
ZIF	Zero Insertion Force

Reference Documents

For additional information, refer to the following documents:

- *Intel® S5000 Server Board Family Datasheet*
- *Intel 5000 Series Chipset Memory Controller Hub Datasheet*
- *Intel 631xESB/632xESB I/O Controller Hub Datasheet*