



Intel® Server System SR1625UR

Technical Product Specification

Intel order number E47487-010



Revision 1.8

December, 2010

Enterprise Platforms and Services Division

Revision History

Date	Revision Number	Modifications
March 2009	1.0	Initial release.
October 2009	1.1	Updated section 9.3 - External Standard Control Panel Connectors.
January 2010	1.2	Updated section 7.2.2 - Intel® IT/IR RAID.
April 2010	1.3	<ul style="list-style-type: none"> ▪ Updated section 2.5 - System Board Overview. ▪ Updated section 4.2.3 - CPU/Memory. ▪ Removed CCC Certification.
June 2010	1.4	Deleted section 3.5.6 - Peripheral Connector.
August 2010	1.5	<ul style="list-style-type: none"> ▪ Updated section 2 - Product Overview. ▪ Added section 2.1 - Processor Support.
October 2010	1.6	Updated section 2.1 - Processor Support.
December 2010	1.7	<ul style="list-style-type: none"> ▪ Updated section 2 - Product Overview. ▪ Updated section 5.1 - Midplane. ▪ Removed section 4.3 - DIMM Blank Population.
December 2010	1.8	<ul style="list-style-type: none"> ▪ Updated section 2 - Product Overview.

Disclaimers

Information in this document is provided in connection with Intel® products. No license, express or implied, by estoppel or otherwise, to any intellectual property rights is granted by this document. Except as provided in Intel's Terms and Conditions of Sale for such products, Intel assumes no liability whatsoever, and Intel disclaims any express or implied warranty, relating to sale and/or use of Intel products including liability or warranties relating to fitness for a particular purpose, merchantability, or infringement of any patent, copyright or other intellectual property right. Intel products are not intended for use in medical, life saving, or life sustaining applications. Intel may make changes to specifications and product descriptions at any time, without notice.

Designers must not rely on the absence or characteristics of any features or instructions marked "reserved" or "undefined." Intel reserves these for future definition and shall have no responsibility whatsoever for conflicts or incompatibilities arising from future changes to them.

The Intel® Server System SR1625UR may contain design defects or errors known as errata which may cause the product to deviate from published specifications. Current characterized errata are available on request.

This document and the software described in it are furnished under license and may only be used or copied in accordance with the terms of the license. The information in this manual is furnished for informational use only, is subject to change without notice, and should not be construed as a commitment by Intel Corporation. Intel Corporation assumes no responsibility or liability for any errors or inaccuracies that may appear in this document or any software that may be provided in association with this document.

Except as permitted by such license, no part of this document may be reproduced, stored in a retrieval system, or transmitted in any form or by any means without the express written consent of Intel Corporation.

Intel, Pentium and Xeon are trademarks or registered trademarks of Intel Corporation.

*Other brands and names may be claimed as the property of others.

Copyright © Intel Corporation 2008-2010. Portions Copyright © 2005-2010 by LSI Corporation.

Table of Contents

1. Introduction	1
1.1 Chapter Outline.....	1
1.2 Server Board Use Disclaimer	2
2. Product Overview.....	3
2.1 Processor Support.....	4
2.1.1 Processor Population Rules	5
2.2 System Overview	7
2.3 System Dimensions	7
2.4 System Components	8
2.5 Hard Drive and Peripheral Bays	9
2.6 System Board Overview	10
2.7 Front Bezel Support.....	14
2.8 Rack and Cabinet Mounting Options	15
3. Power Subsystem	16
3.1 Mechanical Overview.....	16
3.1.1 DC Output Connection (Card Edge).....	17
3.2 Single Power Supply Module Population.....	17
3.3 Handle and Retention Mechanism.....	18
3.4 Hot-swap Support.....	18
3.5 Output Cable Harness	18
3.5.1 P1 – Server Board Power Connector	18
3.5.2 P2 – Processor Power Connector	19
3.5.3 P3 – Power Signal Connector.....	20
3.5.4 P4 – Backplane Power Connector	20
3.5.5 P5 – Midplane Power Connector	20
3.6 AC Input Requirements	21
3.6.1 AC Inlet Connector	21
3.6.2 AC Power Cord Specification Requirements	21
3.6.3 Efficiency	21
3.6.4 AC Input Voltage Specification	22
3.6.5 AC Line Dropout/Holdup.....	22
3.6.6 AC Inrush.....	22

3.6.7	AC Line 5 VSB Holdup	23
3.6.8	AC Line Leakage Current	23
3.6.9	Power Factor Correction	23
3.7	DC Output Specification	23
3.7.1	Output Power/Currents	23
3.7.2	Voltage Regulation	24
3.8	Protection Circuits.....	24
3.8.1	Over-current Protection (OCP)	24
3.8.2	Over-voltage Protection (OVP)	25
3.8.3	Over-temperature Protection (OTP).....	25
3.9	Power Supply Status LED	25
4.	Cooling Subsystem.....	26
4.1	Fan Module.....	26
4.2	Airflow Support	28
4.2.1	Power Supply Zone	28
4.2.2	PCI Riser Zone	29
4.2.3	CPU/Memory	29
4.3	Drive Bay Population	30
4.4	Sata HDD Support.....	30
5.	System Board Interconnects.....	31
5.1	Midplane	31
5.2	Bridge Board.....	37
5.3	Hot-Swap SATA/SAS Backplane.....	38
6.	Peripheral Drive Support	44
6.1	Optical Drive Support.....	44
7.	Hard Disk Drive Support.....	46
7.1	Hard Drive Bays.....	46
7.1.1	Hot-swap Drive Trays	46
7.2	Midplane Options.....	47
7.2.1	Passive Midplane.....	47
7.2.2	Active Midplane with Intel® SAS /SAS RAID Support.....	48
7.3	Hot-Swap SAS/SATA Backplane.....	51
7.3.1	SAS/SATA Backplane Layout.....	51
7.3.2	SAS/SATA Backplane Functional Architecture.....	53
8.	Mini Control Panel Functionality.....	55

8.1	Mini Control Panel Buttons	55
8.2	Mini Control Panel LED Indicators	56
8.2.1	Power/Sleep LED	57
8.2.2	System Status LED.....	57
8.2.3	System Identification LED.....	58
8.3	External Mini Control Panel Connectors	58
8.4	Internal Mini Control Panel Interconnects.....	58
9.	Standard Control Panel Functionality	60
9.1	Standard Control Panel Buttons	60
9.2	Standard Control Panel LED Indicators	61
9.2.1	Power/Sleep LED	62
9.2.2	System Status LED.....	63
9.2.3	Drive Activity LED	63
9.2.4	System Identification LED.....	64
9.3	External Standard Control Panel Connectors	64
9.4	Internal Standard Control Panel Interconnect.....	64
10.	Intel® Local Control Panel Functionality	66
10.1	LED Functionality.....	67
10.1.1	Power/Sleep LED	67
10.1.2	System Status LED.....	68
10.1.3	System Identification LED.....	68
10.2	Intel® Local Control Panel Interconnects	69
11.	PCI Riser Cards and Assembly	71
12.	Environmental Specifications	72
12.1	System Level Environmental Limits	72
12.2	Serviceability and Availability.....	72
12.3	Replacing the Backup Battery	73
13.	Regulatory and Certification Information.....	74
13.1	Product Regulatory Compliance	74
13.1.1	Product Safety Compliance	74
13.1.2	Product EMC Compliance – Class A Compliance	75
13.1.3	Product Ecology Compliance.....	75
13.1.4	Certifications/Registrations/Declarations	75
13.2	Product Regulatory Compliance Markings	76
13.3	Rack Mount Installation Guidelines	78

13.4	Power Cord Usage Guidelines	79
13.5	Electromagnetic Compatibility Notices	80
13.5.1	FCC Verification Statement (USA)	80
13.5.2	ICES-003 (Canada)	81
13.5.3	Europe (CE Declaration of Conformity)	81
13.5.4	VCCI (Japan)	81
13.5.5	BSMI (Taiwan)	81
13.5.6	KCC (Korea)	82
13.6	Regulated Specified Components	82
Appendix A: Integration and Usage Tips.....		83
Appendix B: POST Code Diagnostic LED Decoder		84
Appendix C: POST Code Errors		89
Glossary.....		94
Reference Documents		95

List of Figures

Figure 1. Top Down View – Passive System Shown	7
Figure 2. Major System Components	8
Figure 3. Drive Bay Overview	9
Figure 4. Intel® Server Board S5520UR	10
Figure 5. Intel® Server Board S5520UR Components	11
Figure 6. Back Panel Feature Overview	12
Figure 7. Intel® Light-Guided Diagnostic LEDs - Server Board.....	13
Figure 8. Optional Front Bezel.....	14
Figure 9. Front Bezel Supporting Mini Control Panel.....	14
Figure 10. Front Bezel Supporting Standard Control Panel.....	14
Figure 11. Front Bezel Supporting Intel® Local Control Panel	15
Figure 12. Power Supply Module Enclosure - Dimensional Drawing.....	16
Figure 13. DC Output Connection (Card Edge)	17
Figure 14. Power Supply Module #1 Location	17
Figure 15. AC Power Cord.....	21
Figure 16. Fan Module.....	26
Figure 17. Fan Header Assignments on Midplane.....	28
Figure 18. Power Supply Air Duct.....	29
Figure 19. Air Duct	30
Figure 20. 2.5 inch Drive Blank.....	30
Figure 21. Passive Midplane Board	31
Figure 22. SAS/SAS RAID Midplane Board.....	32
Figure 23. Bridge Board.....	38
Figure 24. Hot-Swap SAS/SATA Backplane (Front Side View)	38
Figure 25. Hot-Swap SAS/SATA Backplane (Back Side View)	39
Figure 26. Slimline Optical Drive Assembly	44
Figure 27. Mini Control Panel with Eight Hard Drives (Front View)	46
Figure 28. Hard Drive Tray Assembly	47
Figure 29. Passive Midplane Board	48
Figure 30. Active Midplane with SAS/SAS RAID Support.....	49
Figure 31. Active Midplane Architecture Diagram.....	50
Figure 32. Hot-Swap SAS/SATA Backplane (Front Side View).....	52

Figure 33. Hot-Swap SAS/SATA Backplane (Back Side View)	52
Figure 34. SAS/SATA Backplane Functional Block Diagram	53
Figure 35. Mini Control Panel Assembly Module	55
Figure 36. Mini Control Panel Buttons	55
Figure 37. Mini Control Panel LEDs.....	56
Figure 38. Mini Control Panel PCB	59
Figure 39. Standard Control Panel Assembly Module	60
Figure 40. Standard Control Panel Buttons	60
Figure 41. Standard Control Panel LEDs.....	61
Figure 42. Standard Control Panel PCB	65
Figure 43. Intel® Local Control Panel Assembly Module.....	66
Figure 44. Intel® Local Control Panel Overview	66
Figure 45. PCI Riser Card Assembly	71
Figure 46. 1U Full-height PCI Express* Riser Card Mechanical Drawing	71
Figure 47. Diagnostic LED Placement Diagram	84

List of Tables

Table 1. System Feature Set	3
Table 2. Mixed Processor Configurations	6
Table 3. System Dimensions	7
Table 4. Drive Overview.....	9
Table 5. Major Board Components	12
Table 6. Power Harness Cable Definitions	18
Table 7. P1 Main Power Connector	19
Table 8. P2 Processor Power Connector.....	19
Table 9. P3 Power Signal Connector.....	20
Table 10. P4 Hard Drive Interface Board Power Connector	20
Table 11. P5 Midplane Power Connector	20
Table 12. AC Power Cord Specification.....	21
Table 13. Efficiency.....	21
Table 14. AC Input Rating.....	22
Table 15. Power Supply Module Load Ratings.....	23
Table 16. Voltage Regulation Limits	24
Table 17. Over-current Protection Limits/240 VA Protection	24
Table 18. Over-voltage Protection (OVP) Limits.....	25
Table 19. LED Indicators	25
Table 20. Fan Connector Pin Assingment	27
Table 21. Fan Header Assignment	28
Table 22. 120-pin Server Board-to-Midplane Bridge Board Connector Pin-out.....	32
Table 23. Midplane Fan Header Pin-outs	34
Table 24. Midplane Power Connector Pin-out	34
Table 25. Midplane-to-Backplane Card Edge Connector #1 Pin-out	35
Table 26. Midplane-to-Backplane Card Edge Connector #2 Pin-out.....	35
Table 27. Active Midplane SAS RAID Battery Backup Connector Pin-out.....	36
Table 28. Passive Midplane SATA/SAS Connector Pin-outs	37
Table 29. 2x4 SAS/SATA Backplane Power Connector Pin-out.....	39
Table 30. 1x7 Tape Drive Option Power Connector Pin-out (J2N2)	39
Table 31. Slimline Optical Drive Slot Connector (J6C1)	39
Table 32. I ² C Connector.....	40

Table 33. PCI Express* x4 Slot Connector from Midplane	40
Table 34. PCI Express* x4 Slot Connector from Midplane	40
Table 35. Intel® Local Control Panel (LCP) Connector	42
Table 36. Control Panel Signal Connector.....	42
Table 37. Control Panel USB Connector	42
Table 38. SAS/SATA Hard Drive Connector Pin-outs	43
Table 39. Slimline Optical Drive Slot Connector (J6C1)	44
Table 40. Hard Drive LED Function Definitions	53
Table 41. Hard Drive Activity LED Functionality	54
Table 42. Mini Control Panel Button Functions.....	56
Table 43. Mini Control Panel LED Functions	56
Table 44. SSI Power LED Operation	57
Table 45. Control Panel LED Operation	57
Table 46. External USB Connectors	58
Table 47. 20-pin Mini Control Panel Interconnect.....	59
Table 48. Standard Control Button and Intrusion Switch Functions.....	61
Table 49. Standard Control Panel LED Functions	62
Table 50. SSI Power LED Operation	62
Table 51. Control Panel LED Operation	63
Table 52. External USB Connectors	64
Table 53. Video Connector	64
Table 54. 50-pin Standard Control Panel Signal Connector	65
Table 55. 10-pin Standard Control Panel USB Connector.....	65
Table 56. LCP Control Panel LED Functions.....	67
Table 57. SSI Power LED Operation	67
Table 58. Control Panel LED Operation	68
Table 59. 50-pin Intel® Local Control Panel Signal Connector.....	69
Table 60. 10-pin Control Panel USB Connector	70
Table 61. Internal NMI/Temp Sensor Header	70
Table 62. System Environmental Limits Summary	72
Table 63. Time Estimate for System Maintenance Procedures.....	72
Table 64. POST Progress Code LED Example	84
Table 65. Diagnostic LED POST Code Decoder	85
Table 66. POST Error Messages and Handling.....	89
Table 67. POST Error Beep Codes	92

Table 68. Integrated BMC Beep Codes 93

< This page is intentionally left blank.>

1. Introduction

This Technical Product Specification (TPS) provides system-specific information detailing the features, functionality, and high-level architecture of the Intel® Server System SR1625UR. The *Intel® Server Board S5520UR Technical Product Specification* should also be referenced to obtain greater detail of functionality and architecture specific to the integrated server board, which are also supported on this server system.

In addition, design-level information for specific subsystems can be obtained by ordering the External Product Specifications (EPS) or External Design Specifications (EDS) for a given subsystem. EPS and EDS documents are not publicly available. They are only made available under NDA with Intel and must be ordered through your local Intel representative. See the *Reference Documents* section at the end of this document for a complete list of available documents.

The Intel® Server System SR1625UR may contain design defects or errors known as errata, which may cause the product to deviate from published specifications. Refer to the *Intel® Server Board S5520UR/ Intel® Server System SR1625UR Specification Update* for published errata.

1.1 Chapter Outline

This document is divided into the following chapters:

- Chapter 1 – Introduction
- Chapter 2 – Product Overview
- Chapter 3 – Power Subsystem
- Chapter 4 – Cooling Subsystem
- Chapter 5 – System Board Interconnects
- Chapter 6 – Peripheral Drive Support
- Chapter 7 – Hard Disk Drive Support
- Chapter 8 – Mini Control Panel Functionality
- Chapter 9 – Standard Control Panel Functionality
- Chapter 10 – Intel® Local Control Panel Functionality
- Chapter 11 – PCI Riser Cards and Assembly
- Chapter 12 – Environmental Specifications
- Chapter 13 – Regulatory and Certification Requirements
- Appendix A – Integration and Usage Tips
- Appendix B – POST Code Diagnostic LED Decoder
- Appendix C – Post Code Errors
- Glossary
- Reference Documents

1.2 Server Board Use Disclaimer

Intel Corporation server boards support add-in peripherals and contain a number of high-density VLSI and power delivery components that need adequate airflow to cool. Intel ensures through its own system development and testing that when Intel server building blocks are used together, the fully integrated system will meet the intended thermal requirements of these components. It is the responsibility of the system integrator who chooses not to use Intel-developed server building blocks to consult vendor datasheets and operating parameters to determine the amount of airflow required for their specific application and environmental conditions. Intel Corporation cannot be held responsible if components fail or the server board does not operate correctly when used outside any of their published operating or non-operating limits.

2. Product Overview

The Intel® Server System SR1625UR is a rack mount 1U server system with features that are designed to support the high-density high-performance computing server market. The system is integrated with an Intel® Server Board S5520UR and is offered in two different system configurations:

- Intel® Server System SR1625UR (Passive system)
- Intel® Server System SR1625URSAS (Active system)

This chapter provides a high-level overview of the system features. Greater detail for each major system component or feature is provided in the following chapters.

Table 1. System Feature Set

Feature	Description
Peripheral Interfaces	<p>External connections:</p> <ul style="list-style-type: none"> ▪ DB-15 video connector (back) ▪ RJ-45 serial Port A connector ▪ Two RJ-45 10/100/1000 Mb network connections ▪ Four USB 2.0 connectors (back) ▪ One USB 2.0 connector (front) <p>Internal connections:</p> <ul style="list-style-type: none"> ▪ One USB 2x5 pin header, which supports two USB 2.0 ports ▪ One low-profile USB 2x5 pin header to support low-profile USB Solid State drives ▪ One DH-10 Serial Port B header ▪ Six Serial ATA (SATA) II connectors ▪ Two I/O module Mezzanine connectors for optional I/O Module support ▪ One RMM3 connector to support optional Intel® Remote Management Module 3 ▪ SATA Software RAID 5 Activation Key connector ▪ One SSI-EEB compliant front panel header ▪ One SSI-EEB compliant 24-pin main power connector ▪ One SSI-compliant 8-pin CPU power connector ▪ One SSI-compliant power supply SMBus connector
Video	<p>On-board ServerEngines* LLC Pilot II Controller</p> <ul style="list-style-type: none"> ▪ Integrated 2D Video Controller ▪ 64 MB DDR2 Memory
LAN	Two 10/100/1000 Intel® 82575 PHYs with Intel® I/O Acceleration Technology 2 support
Expansion Capabilities	One x16 PCI Express* Gen 2 PCI riser slot capable of supporting a full-length full-height PCI Express* add-in card.
Hard Drives	<ul style="list-style-type: none"> ▪ Up to eight 2.5 inch hot-swap SATA/SAS drives with mini control panel. ▪ Up to six 2.5 inch hot-swap SATA/SAS drives with standard control panel or Intel® Local Control Panel.

Feature	Description
Peripherals	<ul style="list-style-type: none"> ▪ Slimline bay for slimline SATA optical drive. ▪ One PCI Express* X16 add-in card slot (Gen 2).
Control Panel (dependent on option selected)	<ul style="list-style-type: none"> ▪ Standard control panel ▪ Intel® Local Control Panel ▪ Mini control panel
LEDs and displays (dependent on option selected)	<p>With Mini control panel:</p> <ul style="list-style-type: none"> ▪ Power/Sleep ▪ System Status ▪ System Identification <p>Intel® Light-Guided diagnostic LEDs:</p> <ul style="list-style-type: none"> ▪ Fan Fault ▪ DIMM Fault ▪ CPU Fault ▪ 5V-STBY ▪ System Status ▪ System Identification ▪ POST Code Diagnostics
Power Supply	Up to two 650-W power supply modules
Fans	<ul style="list-style-type: none"> ▪ Five 40x40x56-mm dual-rotor system fans ▪ Two 56-mm dual-rotor power supply fans
Server Management	<p>On-board ServerEngines* LLC Pilot II Controller</p> <ul style="list-style-type: none"> ▪ Integrated Baseboard Management Controller (Integrated BMC), IPMI 2.0 compliant. ▪ Integrated Super I/O on LPC interface. <p>Support for Intel® Server Management Software 3.1.</p>

2.1 Processor Support

The Intel® Server Boards S5520UR supports the following processors:

- One or two Intel® Xeon® Processor 5500 Series with a 4.8 GT/s, 5.86 GT/s, or 6.4 GT/s Intel® QPI link interface and Thermal Design Power (TDP) up to 95 W.
- One or two Intel® Xeon® Processor 5600 Series with a 6.4 GT/s Intel® QPI link interface and Thermal Design Power (TDP) up to 130 W.

Note: When configured with 130W processors, only Single & Dual Rank DIMMs are supported.

The server boards do not support previous generations of the Intel® Xeon® Processors.

For a complete updated list of supported processors,

see: <http://support.intel.com/support/motherboards/server/S5520UR/>.

On the Support tab, look for **Compatibility** and then **Supported Processor List**.

2.1.1 Processor Population Rules

Note: Although the server board does support dual-processor configurations consisting of different processors that meet the defined criteria below, Intel does not perform validation testing of this configuration. For optimal system performance in dual-processor configurations, Intel recommends that identical processors be installed.

When using a single processor configuration, the processor must be installed into the processor socket labeled CPU1. A terminator is not required in the second processor socket when using a single processor configuration.

When two processors are installed, the following population rules apply:

- Both processors must be of the same processor family.
- Both processors must have the same front-side bus speed.
- Both processors must have the same cache size.
- Processors with different speeds can be mixed in a system, given the prior rules are met. If this condition is detected, all processor speeds are set to the lowest common denominator (highest common speed) and an error is reported.
- Processor stepping within a common processor family can be mixed as long as it is listed in the processor specification updates published by Intel Corporation.

The following table describes mixed processor conditions and recommended actions for all Intel® server boards and systems that use the Intel® 5520 Chipset. The errors fall into one of the following two categories:

- **Fatal:** If the system can boot, it goes directly to the error manager, regardless of whether the **Post Error Pause** setup option is enabled or disabled.
- **Major:** If the **Post Error Pause** setup option is enabled, system goes directly to the error manager. Otherwise, the system continues to boot and no prompt is given for the error. The error is logged to the error manager.

Table 2. Mixed Processor Configurations

Error	Severity	System Action
Processor family not identical	Fatal	<p>The BIOS detects the error condition and responds as follows:</p> <ul style="list-style-type: none"> ▪ Logs the error into the system event log (SEL). ▪ Alerts the Integrated BMC of the configuration error with an IPMI command. ▪ Does not disable the processor. ▪ Displays “0194: Processor family mismatch detected” message in the error manager. ▪ Halts the system.
Processor cache not identical	Fatal	<p>The BIOS detects the error condition and responds as follows:</p> <ul style="list-style-type: none"> ▪ Logs the error into the SEL. ▪ Alerts the Integrated BMC of the configuration error with an IPMI command. ▪ Does not disable the processor. ▪ Displays “0192: Cache size mismatch detected” message in the error manager. ▪ Halts the system.
Processor frequency (speed) not identical	Major	<p>The BIOS detects the error condition and responds as follows:</p> <ul style="list-style-type: none"> ▪ Adjusts all processor frequencies to lowest common denominator. ▪ Continues to boot the system successfully. <p>If the frequencies for all processors cannot be adjusted to be the same, then the BIOS:</p> <ul style="list-style-type: none"> ▪ Logs the error into the SEL. ▪ Displays “0197: Processor speeds mismatched” message in the error manager. ▪ Halts the system.
Processor microcode missing	Fatal	<p>The BIOS detects the error condition and responds as follows:</p> <ul style="list-style-type: none"> ▪ Logs the error into the SEL. ▪ Alerts the Integrated BMC of the configuration error with an IPMI command. ▪ Does not disable processor. ▪ Displays “816x: Processor 0x unable to apply microcode update” message in the error manager. ▪ Pauses the system for user intervention.
Processor Intel® QuickPath Interconnect speeds not identical	Halt	<p>The BIOS detects the error condition and responds as follows:</p> <ul style="list-style-type: none"> ▪ Logs the error into the system event log (SEL). ▪ Alerts the Integrated BMC of the configuration error with an IPMI command. ▪ Does not disable the processor. ▪ Displays “0195: Processor Front Side Bus speed mismatch detected” message in the error manager. ▪ Halts the system.

2.2 System Overview



Figure 1. Top Down View – Passive System Shown

2.3 System Dimensions

Table 3. System Dimensions

Height	43.2 mm	1.70 in
Width without rails	430.0 mm	16.93 in
Width with rails	470.0 mm	18.50 in
Depth without CMA	665.5 mm	26.2 in
Depth with CMA	812.8 mm	32.00 in
Maximum Weight	38.1 mm	1.50 in

2.4 System Components

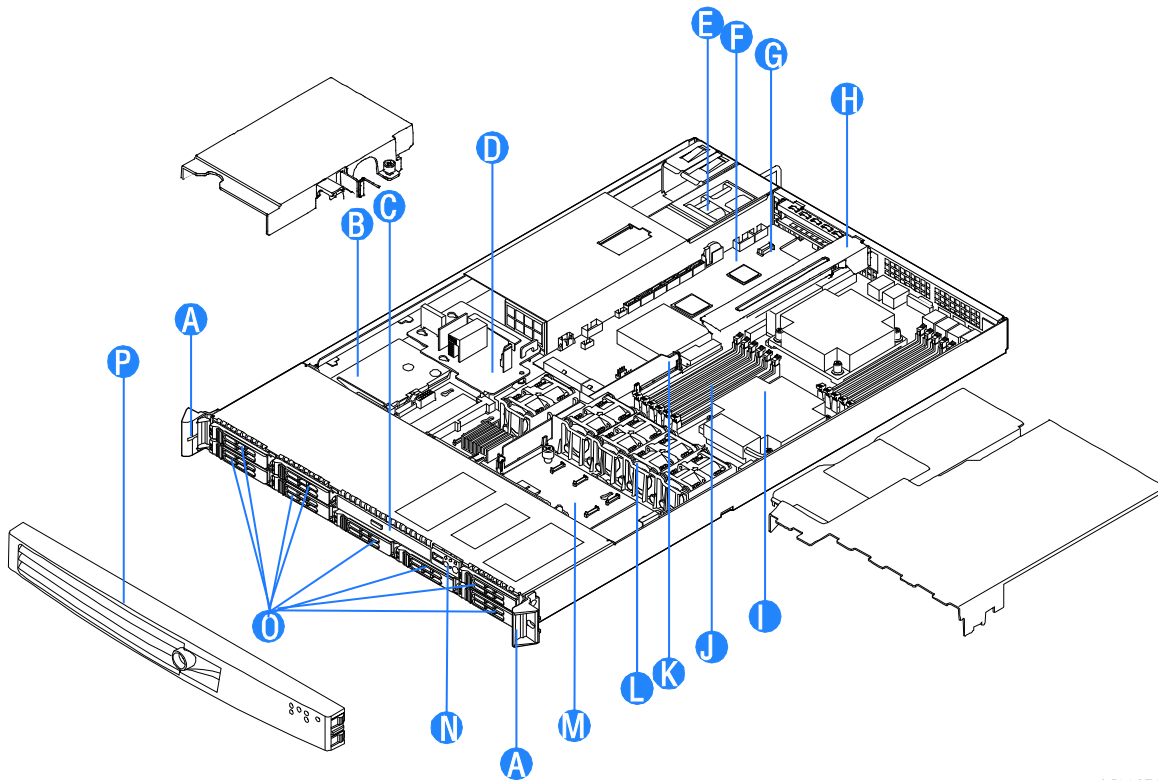

AF002793

A	Rack Handles	I	Processor 2 and Heatsink
B	RAID Backup Battery Pack (Optional)	J	System Memory
C	Slimline Optical Drive Bay	K	Bridge Board
D	Power Distribution Board	L	System Fan Bank
E	Power Supply Modules	M	Midplane Board (Active version shown)
F	Server Board	N	Mini Control Panel
G	Intel® I/O Expansion Module Connector	O	Hard Drive Bays
H	Riser Card Assembly	P	Front Bezel (Optional; Standard Control Panel shown)

Not shown: SAS/SATA Backplane; Standard Control Panel or Intel® Local Control Panel

Figure 2. Major System Components

2.5 Hard Drive and Peripheral Bays

The system is designed to support 2.5 inch hot-swap SAS or SATA hard disk drives. When configured with the Mini Control Panel option, the system can support up to eight 2.5 inch drives. When configured with the Standard Control Panel or Intel® Local Control Panel, the system can support up to six 2.5 inch drives. The slimline peripheral bay is capable of supporting one of the following devices: CD-ROM, DVD, or DVD-CDR.

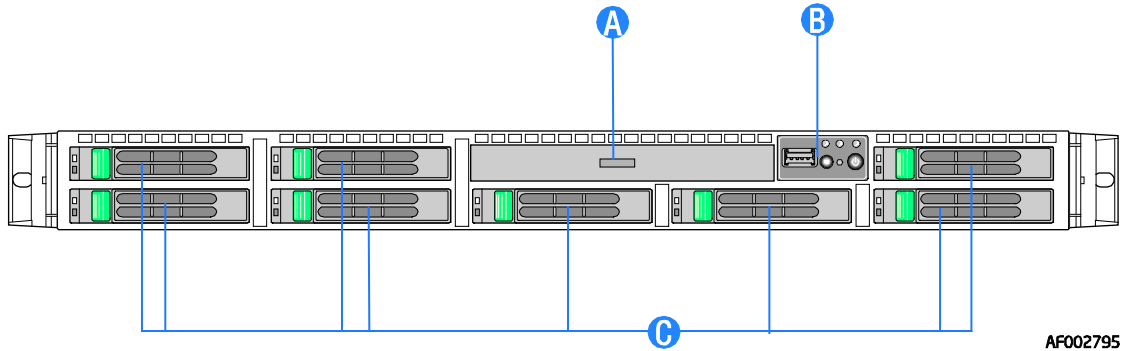

AF002795

A	Slimline Optical Drive Bay
B	Mini Control Panel
C	2.5 inch Hard Drive Bays (Up to eight drives supported with the Mini Control Panel)

Figure 3. Drive Bay Overview

Table 4. Drive Overview

	Passive System Product Code - SR1625UR	Active System Product Code - SR1625URSAS
Slimline SATA Optical Drive	Supported	Supported
Slimline USB Floppy Drive	No Support	No Support
SATA Drives	Up to 8 drives supported	Up to 8 drives supported
SAS Drives	No Support	Up to 8 drives supported

2.6 System Board Overview



Figure 4. Intel® Server Board S5520UR

The following figure shows the board layout of the server board. Each connector and major component is identified by a number or letter, and a description is given below the figure.

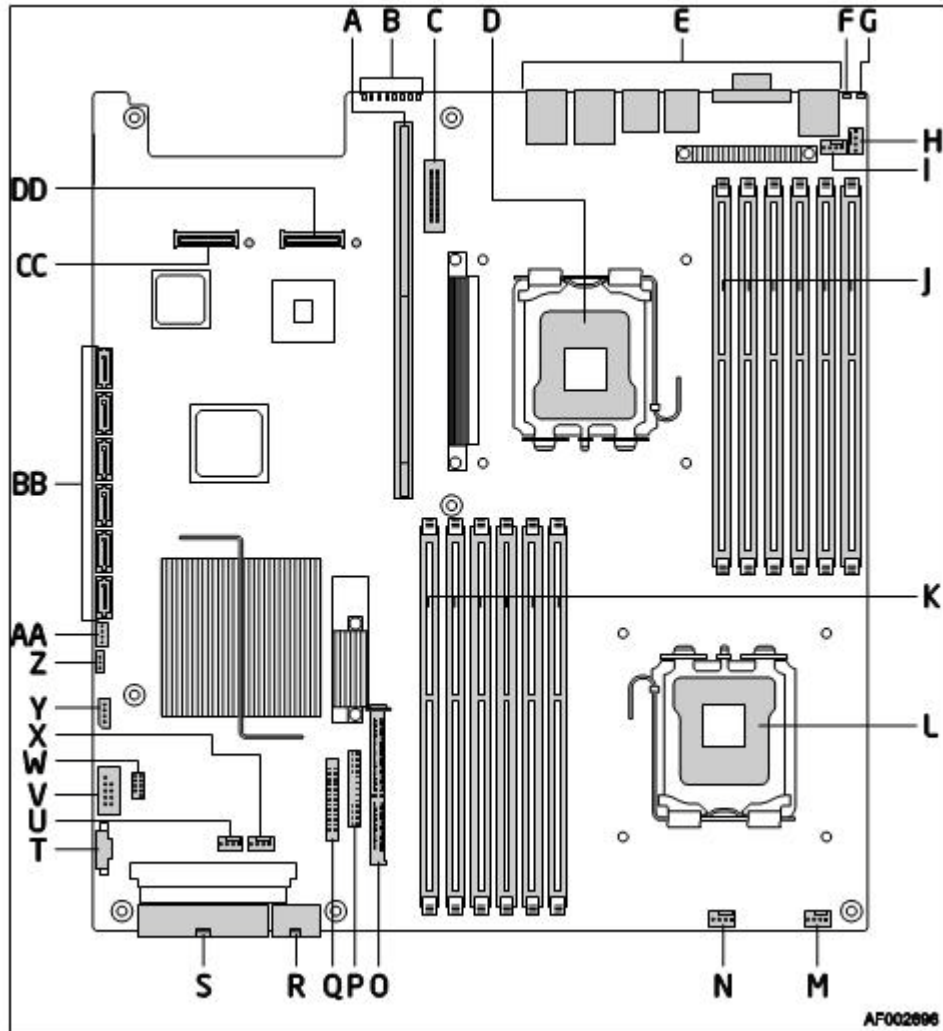
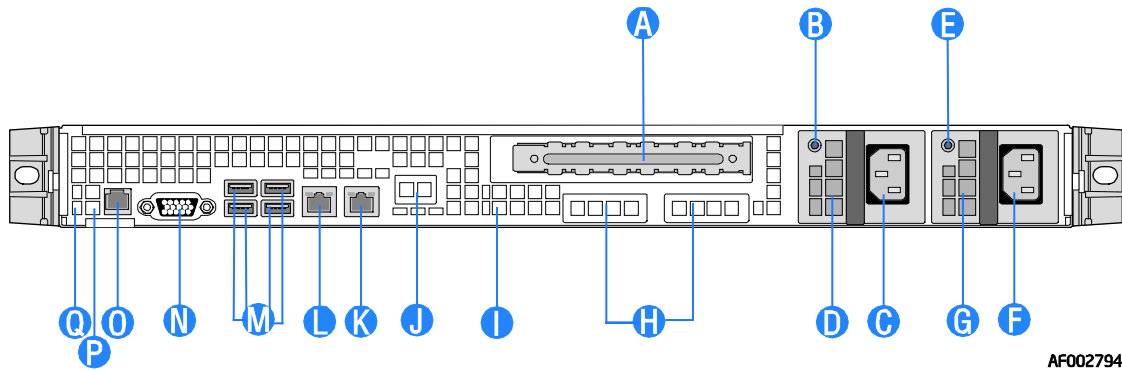

Figure 5. Intel® Server Board S5520UR Components

Table 5. Major Board Components

	Description		Description
A	280-pin Intel® Adaptive Riser Card Slot	Q	Fan Board Connector (Intel® Server Chassis)
B	POST Code LEDs	R	2x4 Power Connector
C	Intel® RMM3 Header	S	Main Power Connector
D	Processor 1	T	Power Supply SMBus Connector
E	Back Panel I/O	U	Fan Header
F	ID LED	V	USB Header
G	System Status LED	W	Low-profile USB Solid State Driver Header
H	Fan Header	X	Fan Header
I	Fan Header	Y	LCP IPMB Header
J	Processor 1 DIMM Slots	Z	SATA RAID 5 Key Header
K	Processor 2 DIMM Slots	AA	SGPIO Header
L	Processor 2	BB	SATA Connectors
M	Fan Header	CC	I/O Module Mezzanine Connector 2
N	Fan Header	DD	I/O Module Mezzanine Connector 1
O	Bridge Board Connector (Intel® Server Chassis)		
P	Front Panel Connector		



AF002794

A	Full-height PCI Add-in Card Slot	J	Intel® Remote Management Module NIC (Optional)
B	Supply Module #1 Status LED	K	NIC 2
C	Supply Module #1 AC Receptacle	L	NIC 1
D	Supply Module #1	M	Four USB ports
E	Supply Module #2 Status LED	N	Video
F	Supply Module #2 AC Receptacle	O	RJ-45 Serial B Connector
G	Supply Module #2 (Optional)	P	System Status LED
H	I/O Modules (Optional)	Q	System Identification LED
I	Post Code Diagnostics LEDs		

Figure 6. Back Panel Feature Overview

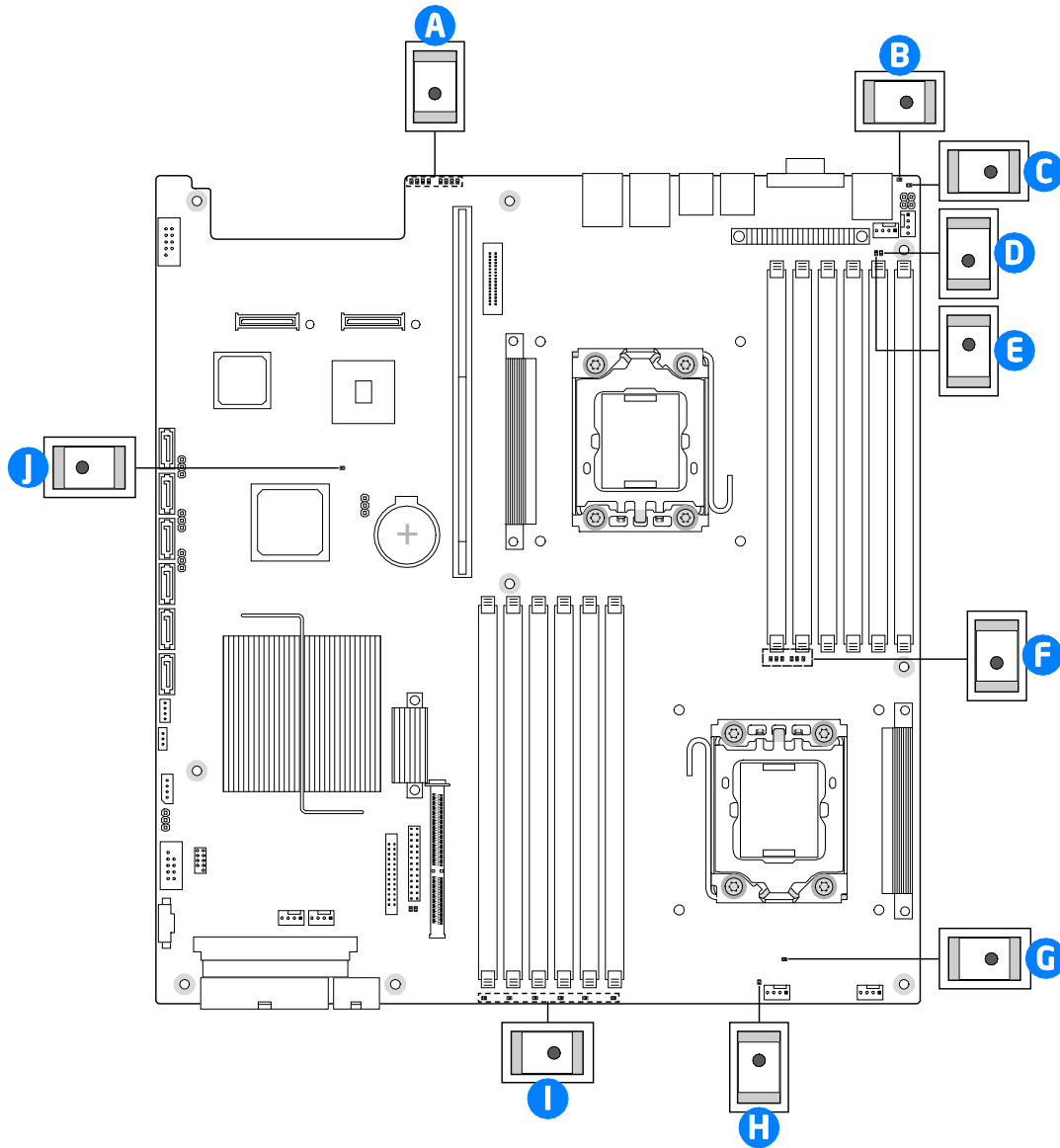

AF002833

AF002833

A	POST Code Diagnostic LEDs	F	CPU 1 DIMM Fault LEDs
B	System Identification LED	G	CPU 2 Fan Fault LED
C	Status LED	H	Memory 2 Fan Fault LED
D	Memory 1 Fan Fault LED	I	CPU 2 DIMM Fault LEDs
E	CPU 1 Fan Fault LED	J	5V Standby LED

Figure 7. Intel® Light-Guided Diagnostic LEDs - Server Board

2.7 Front Bezel Support

The optional front bezel is made of molded plastic and uses a snap-on design with a key lock. When installed, its design allows for maximum airflow.

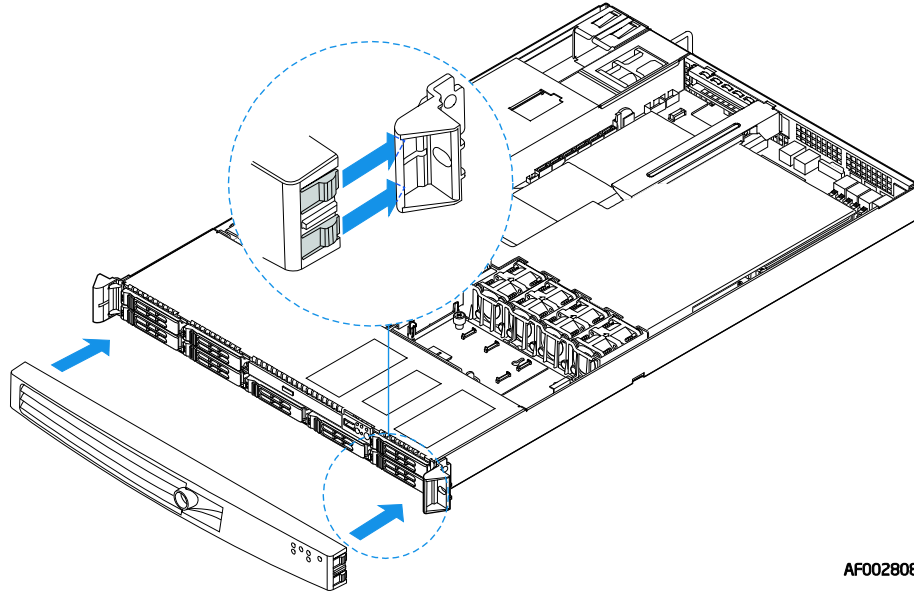

AF002808

Figure 8. Optional Front Bezel

Separate front bezels are available to support systems that use either a Mini Control Panel, Standard Control Panel or Intel® Local Control Panel with LCD support.

When either the Mini Control Panel or the Standard Control Panel is used, light pipes on the back side of the front bezel allow the system status LEDs to be monitored with the front bezel installed. The front bezel lock is provided to prevent unauthorized access to hard drives, peripheral devices and the control panel buttons and I/O ports.



AF002799

Figure 9. Front Bezel Supporting Mini Control Panel

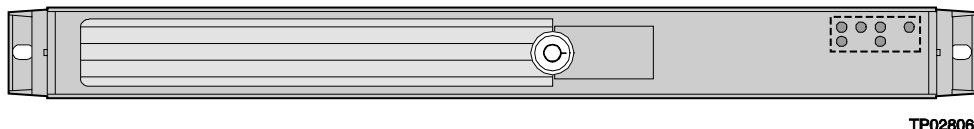

TP02806

Figure 10. Front Bezel Supporting Standard Control Panel

When the Intel® Local Control Panel is used, the control panel module can be adjusted to extend further out from the chassis face to allow the LCD panel to protrude from the front bezel.



TP02807

Figure 11. Front Bezel Supporting Intel® Local Control Panel

2.8 Rack and Cabinet Mounting Options

The system was designed to support 19 inches wide by up to 30 inches deep server cabinets. The system supports three rack mount options:

- A fixed mount relay rack/cabinet mount kit (Product Order Code - AXXBRACKETS) which can be configured to mount the system into either a 2-post rack or 4-post cabinet
- A tool-less full extracting slide rail kit (Product Order Code – AXXHERAIL2) designed to support an optional cable management arm (Product Order code – AXXRACKCARM2).
- A basic slide rail kit (Product Order Code – AXXBASRAIL13) designed to mount the system into a standard (19 inches by up to 30 inches deep) EIA-310D compatible server cabinet.

3. Power Subsystem

The power subsystem of the system consists of an integrated Power Distribution Module (PDM), a Power Module Enclosure, and support for up to two 650-W power supply modules. The power subsystem can be configured to support a single module in a 1+0 non-redundant configuration, or dual modules in a 1+1 redundant power configuration. In a 1+1 configuration, a single failed power module can be hot-swapped with the system running. Either configuration supports up to a maximum of 650 Watts of power.

This chapter provides technical details on the operation of the power supply module and power subsystem. For additional information, refer to the *Intel® Server System SR1625 AC Power Supply Specification* and the *Intel® Server System SR1625 Power Distribution Module Specification*.

3.1 Mechanical Overview

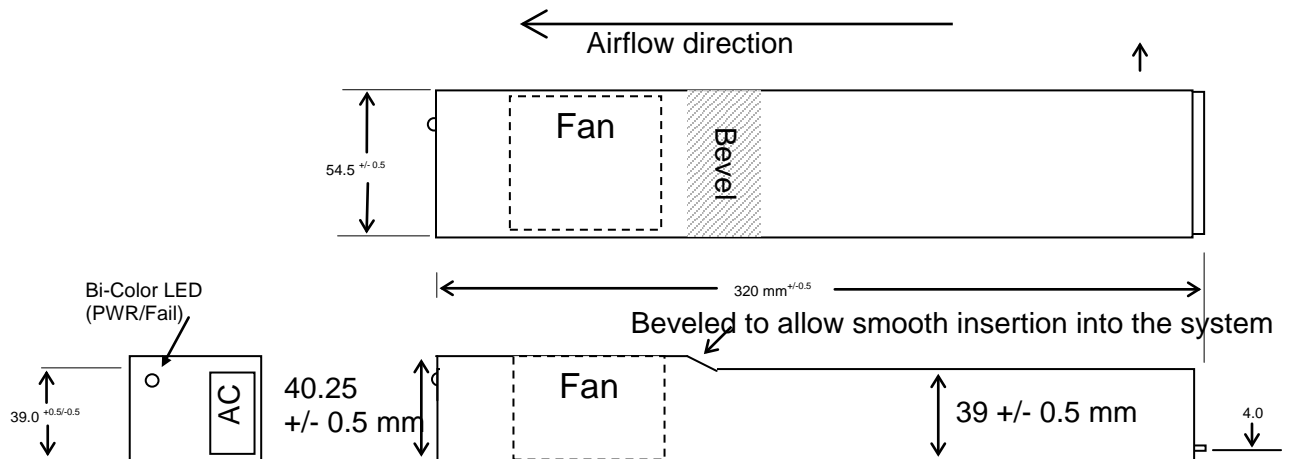

Notes:

1. All dimensions are in mm.
2. AC inlet can protrude beyond the front panel of the power supply module.
3. Fans are powered from +12 V when power supplies are ON.
4. Fans are powered from 5 VSB when in standby mode.

Figure 12. Power Supply Module Enclosure - Dimensional Drawing

3.1.1 DC Output Connection (Card Edge)

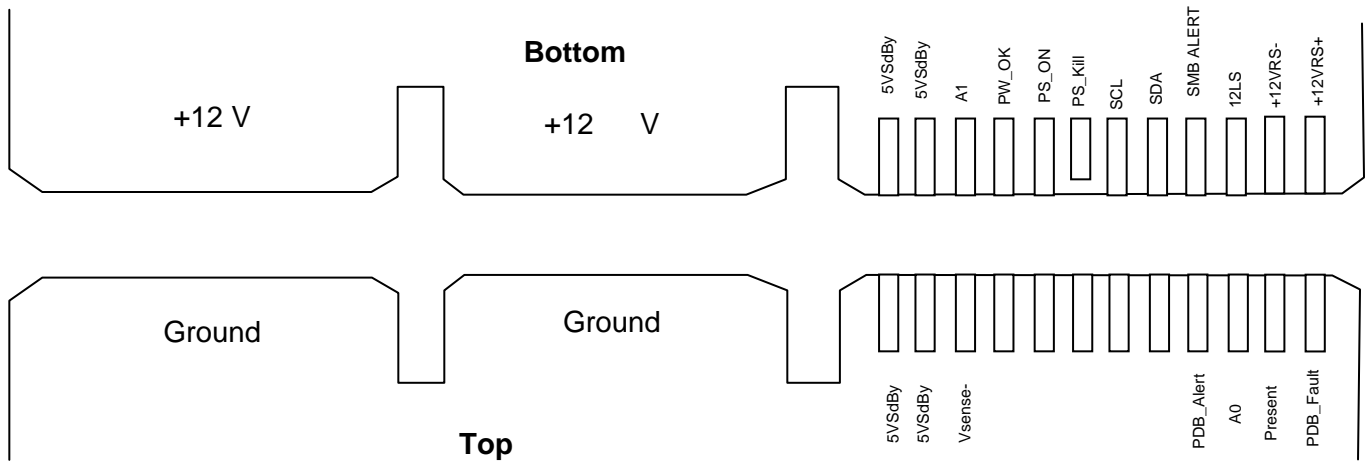

Figure 13. DC Output Connection (Card Edge)

3.2 Single Power Supply Module Population

In single power module configurations, the server management firmware requires that power supply module #1 be populated. The power module #1 slot is located closest to the server board away from the side edge of the system (see Figure 14). The non-operating slot must have the power supply blank installed.

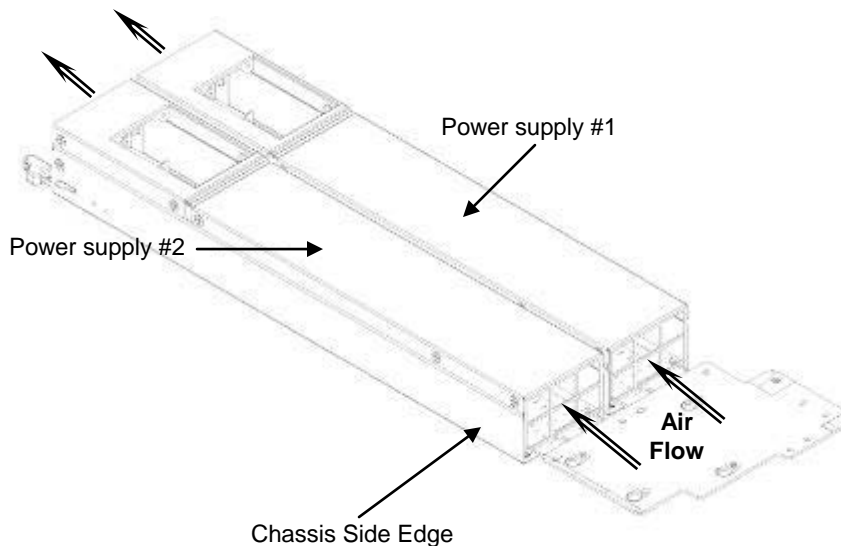

Figure 14. Power Supply Module #1 Location

Configuring a single power supply module in the #2 module slot causes the server management firmware and BIOS to generate a system error during POST and the error is reported to the System Event Log. It also causes the system status LED on the control panel to blink green, denoting a degraded system configuration.

3.3 Handle and Retention Mechanism

The power supply includes a handle to grip the power supply for removal and insertion. The power supply has a simple retention mechanism to retain the power supply once it is inserted. This mechanism withstands the specified mechanical shock (50 G) and vibration requirements.

The handle protects the operator from any burn hazard through the use of the specially designed handle. The handle is made of aluminum and black in color. The knob for the latch is made of plastic per the material/color listed below.

Material	Color	Designation
GE 2800	Green	GN3058
BAYER FR2000	Green	3200

3.4 Hot-swap Support

Hot-swapping a power supply module is the process of extracting and re-inserting a power supply module from an operating power system. During this process, the output voltages remain within specified limits. Up to two power supply modules may be on a single AC line. The power supply module can be hot-swapped using the following method:

1. **Extraction:** To remove the power supply, unplug the power cord first, and then remove the power module. This can be done in standby mode or power-on mode.
2. **Insertion:** Insert the module first, and then plug in the power cord. If the system is powered off, the system and the power supply will power on into standby mode or power-on mode.

3.5 Output Cable Harness

The power distribution board has a wire harness output with the connectors listed in the following table. Listed or recognized component appliance wiring material (AVLV2), CN rated minimum 105°C, 300 VDC is used for all output wiring.

Table 6. Power Harness Cable Definitions

Connector #	No. of pins	Description
P1	2x12	Main Power Connector
P2	2x4	Processor and Memory Power Connector
P3	1x5	Server board Signal Connector
P4	2x4	Backplane Power Connector
P5	2x5	Midplane Power Connector
P6	1x4	Reserved Power (Pin holes available on PDB but cable not stuffed)

3.5.1 P1 – Server Board Power Connector

Connector housing: 24-pin Molex* Mini-Fit Jr. 39-01-2245 or Intel approved equivalent

Contact: Molex Mini-Fit, HCS, Female, Crimp 44476-1111 or Intel approved equivalent

Table 7. P1 Main Power Connector

Pin	Signal	18 AWG Color	Pin	Signal	18 AWG Color
1	+3.3 VDC	Orange	13	+3.3 VDC	Orange
2	+3.3 VDC	Orange	14	-12 VDC	Blue
3	COM	Black	15	COM	Black
4	+5 VDC*	Red	16	PSO#	Green
5	COM	Black	17	COM	Black
6	+5 VDC	Red	18	COM	Black
7	COM	Black	19	COM	Black
8	PWR OK	Gray	20	Reserved	N.C.
9	5 VSB	Purple	21	+5 VDC	Red
10	+12 V3	Yellow/Blue Stripe	22	+5 VDC	Red
11	+12 V3	Yellow/Blue Stripe	23	+5 VDC	Red
12	+3.3 VDC	Orange	24	COM	Black

Note: 5 V Remote Sense Double Crimped into pin 4.

3.5.2 P2 – Processor Power Connector

Connector housing: 8-pin Molex* 39-01-2085 or Intel approved equivalent

Contact: Molex 45750-0112 (12A) or Intel approved equivalent

Table 8. P2 Processor Power Connector

Pin	Signal	16 AWG Color	Pin	Signal	16 AWG Color
1	COM	Black	5	+12 V1	Yellow
2	COM	Black	6	+12 V1	Yellow
3	COM	Black	7	+12 V2	Yellow/Black Stripe
4	COM	Black	8	+12 V2	Yellow/Black Stripe

3.5.3 P3 – Power Signal Connector

Connector housing: 5-pin Molex* 50-57-9705 or Intel approved equivalent

Contact: Molex 16-02-0087 or Intel approved equivalent

Table 9. P3 Power Signal Connector

Pin	Signal	24 AWG Color
1	I ² C Clock	White/Green Stripe
2	I ² C Data	White/Yellow Stripe
3	SMBAlert#	White
4	ReturnS	Black
5	3.3RS	White/Brown Stripe

3.5.4 P4 – Backplane Power Connector

Connector housing: 8-pin Molex* 39-01-2085 or Intel approved equivalent

Contact: Molex 44476-1111 or Intel approved equivalent

Table 10. P4 Hard Drive Interface Board Power Connector

Pin	Signal	18 AWG Color	Pin	Signal	18 AWG Color
1	COM	Black	5	+12 V4	Yellow/White Stripe
2	COM	Black	6	+12 V4	Yellow/White Stripe
3	+5 V	Red	7	+5 VSB	Purple
4	+5 V	Red	8	+3.3 V	Orange

3.5.5 P5 – Midplane Power Connector

Connector housing: 10-pin Molex* Microfit PN # 43025-1000 or Intel approved equivalent

Contact: Molex Microfit, Female, Crimp 43030-0007 or Intel approved equivalent

Table 11. P5 Midplane Power Connector

Pin	Signal	20 AWG Color	Pin	Signal	20 AWG Color
1	COM	Black	6	+12 V4	Yellow/White Stripe
2	COM	Black	7	+12 V4	Yellow/White Stripe
3	+5 V	Red	8	+12 V4	Yellow/White Stripe
4	+3.3 V	Orange	9	+12 V4	Yellow/White Stripe
5	COM	Black	10	+5 VSB	Purple

3.6 AC Input Requirements

The power supply module incorporates universal power input with active power factor correction, which reduces line harmonics in accordance with the EN61000-3-2 and JEIDA MITI standards.

3.6.1 AC Inlet Connector

The AC input connector is an IEC 320 C-14 power inlet. This inlet is rated for 15 A/250 VAC.

3.6.2 AC Power Cord Specification Requirements

The AC power cord used must meet the minimum specification requirements listed in the following table.

Table 12. AC Power Cord Specification

Cable Type	SVT
Wire Size	18 AWG
Temperature Rating	60°C
Amperage Rating	10 A
Voltage Rating	125 V

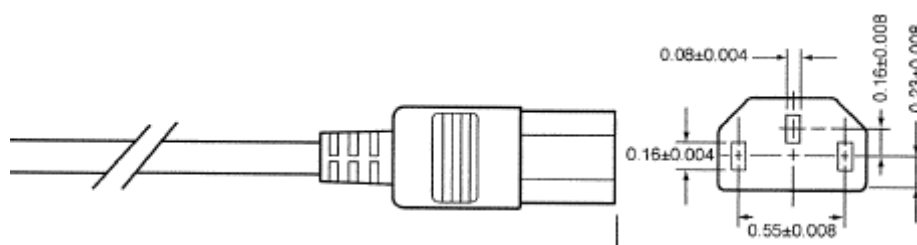

Figure 15. AC Power Cord

3.6.3 Efficiency

The following table provides the recommended efficiency level for the power supply module. Efficiency is tested at 230 V input voltage.

Table 13. Efficiency

Power Supply Version	20% of maximum	50% of maximum	100% of maximum
650 W	81%	85%	81%

3.6.4 AC Input Voltage Specification

The power supply must operate within all specified limits over the input voltage range shown in the following table:

Table 14. AC Input Rating

Parameter	Minimum	Rated	Maximum	Startup VAC	Power-off VAC	Maximum Input AC Current	Maximum Rated Input AC Current
Line Voltage (110)	90 V _{rms}	100-127 V _{rms}	140 V _{rms}	85 VAC ±4 VAC	75 VAC ± 5 VAC	8.5 A _{rms} ^{1,3}	7.6 A _{rms} ⁴
Line Voltage (220)	180 V _{rms}	200-240 V _{rms}	264 V _{rms}	-	-	4.2 A _{rms} ^{2,3}	3.8 A _{rms} ⁴
Frequency	47 Hz	50/60 Hz	63 Hz				

Notes:

1. Maximum input current at low input voltage range is measured at 90 VAC, at maximum load.
2. Maximum input current at high input voltage range is measured at 180 VAC, at maximum load.
3. This is not to be used for determining agency input current markings.
4. Maximum rated input current is measured at 100 VAC and 200 VAC.

Harmonic distortion of up to 10% of the rated AC input voltage must not cause the power supply to go out of specified limits. The power supply powers off on or after/below 75 VAC ± 5 VAC range. The power supply starts up on or before/above 85 VAC ± 4 VAC. Application of an input voltage below 85 VAC does not cause damage to the power supply or blow a fuse.

3.6.5 AC Line Dropout/Holdup

An AC line dropout is defined to be when the AC input drops to 0 VAC at any phase of the AC line for any length of time. During an AC dropout of one cycle or less, the power supply must meet dynamic voltage regulation requirements over the rated load. An AC line dropout of one cycle or less (20 ms minimum) does not cause any tripping of control signals or protection circuits (= 20 ms holdup time requirement). If the AC dropout lasts longer than one cycle, the power supply should recover and meet all turn-on requirements. The power supply must meet the AC dropout requirement over rated AC voltages, frequencies, and output loading conditions. Any dropout of the AC line does not cause damage to the power supply.

The minimum holdup time requirement is as follows:

- 20 ms minimum when tested under the following conditions: Maximum combined load = 360 W (55%)
- 12 ms minimum when tested under the following conditions: Maximum combined load = 600 W (92%)

3.6.6 AC Inrush

The peak AC inrush current is less than 40 A peak for one-quarter of the AC cycle and less than the ratings of power supply's critical AC input components, including input fuse, bulk caps, rectifiers, and surge limiting device.

The power supply must meet the AC inrush current requirements for any rated AC voltage, during turn-on at any phase of AC voltage, during a single cycle AC dropout condition as well as upon recovery after AC dropout of any duration, and over the specified temperature range T_{op} , (includes hot and cold inrush). It is acceptable that AC line inrush current may reach up to 60 A peak for up to 1 msec.

3.6.7 AC Line 5 VSB Holdup

The 5 VSB output voltage stays in regulation under its full load (static or dynamic) during an AC dropout of 70 ms minimum (=5 VSB holdup time) regardless of whether the power supply is in ON or OFF state (PSON asserted or de-asserted).

3.6.8 AC Line Leakage Current

The maximum leakage current to ground for each power supply is not more than 3.5 mA when tested at 240 VAC.

3.6.9 Power Factor Correction

The power supply incorporates a Power Factor Correction circuit.

The power supply is tested as described in *EN 61000-3-2: Electromagnetic Compatibility (EMC) Part 3: Limits - Section 2: Limits for harmonic current emissions*, and meets the harmonic current emissions limits specified for ITE equipment.

The power supply is tested as described in *JEIDA MITI Guideline for Suppression of High Harmonics in Appliances and General-Use Equipment* and meets the harmonic current emissions limits specified for ITE equipment.

3.7 DC Output Specification

3.7.1 Output Power/Currents

The following table defines the power requirements for the power supply module.

Table 15. Power Supply Module Load Ratings

Voltage	650 W		
	Minimum	Maximum	Peak
+12 V	0 A	54 A	61 A ⁴
+5 VSB ^{1,2}	0.1 A	3.0 A	3.5 A
Vbias ³	0 A	See note 3	---

Notes:

1. The two 40-mm fans are powered from 5 VSB when in standby mode.
2. +5 VSB provides power to the two 40-mm fans cooling the power supplies in standby mode. 1 A of 5 VSB is reserved for powering the fan in standby mode.
3. Vbias maximum load is based on PDB circuits. This output is optional depending on whether the PDB requires a higher voltage to power its 240 VA circuits.
4. Peak current time duration does not exceed 12 sec.

3.7.2 Voltage Regulation

The power supply output voltages must stay within the voltage limits defined in the following table when operating at steady state and dynamic loading conditions. These limits include the peak-peak ripple/noise. All outputs are measured with reference to the return remote sense signal (ReturnS). The +12 V and +5 VSB voltages are measured at the PDB output harness connector.

Table 16. Voltage Regulation Limits

Output	Tolerance	Minimum	Normal	Maximum	Units
+ 12 V	- 5%/+5%	+11.40	+12.00	+12.60	V _{DC}
+ 5 VSB	- 5%/+5%	+4.75	+5.00	+5.25	V _{DC}

3.8 Protection Circuits

Protection circuits inside the PDB and the power supply cause the power supply's main +12 V output to shut down, or cause a shutdown of any of the three outputs on the PDB. Any one of these shutdowns results in shutting down the entire power supply/PDB combination. If the power supply latches off due to a protection circuit tripping, an AC cycle OFF for 15 seconds minimum or a PSON[#] cycle HIGH for 1 second resets the power supply and the PDB.

3.8.1 Over-current Protection (OCP)

Each DC/DC converter output on the PDB has individual OCP protection circuits. The power supply and power distribution board combination (PS and PDB) shut down and latch off after an over-current condition occurs. This latch is cleared by toggling the PSON[#] signal or by an AC power interruption. The over-current limits are measured at the PDB harness connectors.

The DC/DC converters are not damaged from repeated power cycling in this condition. Also, the +12 V output from the power supply is divided on the PDB into four channels and each is limited to 240 VA of power. Current sensors and limit circuits shut down the entire PS and PDB if the limit is exceeded. The limits are listed in the following table. -12 V and 5 VSB are protected under over-current or shorted conditions so that no damage can occur to the power supply. Auto-recovery feature is a requirement on 5 VSB rail.

Table 17. Over-current Protection Limits/240 VA Protection

Output Voltage	Minimum OCP Trip Limits	Maximum OCP Trip Limits
+3.3 V	13.2 A	18 A
+5 V	26 A	30 A
-12 V	protected under over-current or shorted conditions	
+12 V1	18.2 A	20 A
+12 V2	18.2 A	20 A
+12 V3	18.2 A	20 A
+12 V4	18.2 A	20 A
+5 VSB	protected under over-current or shorted conditions with auto recovery	

3.8.2 Over-voltage Protection (OVP)

Each DC/DC converter output on the PDB has individual OVP protection circuits built in and they are locally sensed. The PS and PDB shut down and latch off after an over-voltage condition occurs. This latch is cleared by toggling the PSON[#] signal or by an AC power interruption. The over-voltage limits are measured at the PDB harness connectors and are listed in the following table. The voltage never exceeds the maximum levels when measured at the power pins of the output harness connector during any single point of fail. The voltage never trips any lower than the minimum levels when measured at the power pins of the PDB connector.

Table 18. Over-voltage Protection (OVP) Limits

Output Voltage	OVP Minimum (V)	OVP Maximum (V)
+3.3 V	3.9	4.5
+5 V	5.7	6.2
+12 V1,2, 3, 4	13.3	14.5
-12 V	-13.3	-14.5
+5 VSB	5.7	6.5

3.8.3 Over-temperature Protection (OTP)

The PS and PDB are protected against over-temperature conditions caused by loss of fan cooling, excessive ambient temperature, or excessive loading. Two sensing points are placed at hot spots: one near the exterior face and the other near the interior face of the module. In an OTP condition, the PSU shuts down. When the power supply temperature drops to within specified limits, the power supply restores the power automatically, while 5 VSB always remains on. The OTP circuit must have built in hysteresis such that the power supply does not oscillate on and off due to a temperature recovery condition. The OTP trip level has a minimum of 4°C of ambient temperature hysteresis.

3.9 Power Supply Status LED

Each power supply module has a single bi-color LED to indicate power supply status. The LED operation is defined in the following table:

Table 19. LED Indicators

Power Supply Condition	Bi-Color LED
No AC power to all power supplies	Off
No AC power to this PSU only (for 1+1 configuration) or Power supply critical event causing a shutdown: failure, fuse blown (1+1 only), OCP, OVP, Fan Failed	Amber
Power supply warning events where the power supply continues to operate: high temp, high power, high current, slow fan.	1 Hz Blink Amber
AC present/Only 5 VSB on (PS Off)	1 Hz Blink Green
Output ON and OK	Green

The LED is visible on the rear panel of each installed power supply module.

4. Cooling Subsystem

Several components and configuration requirements make up the cooling subsystem. These include the system fan module, the power supply fans, power supply air duct, CPU air duct, DIMM blanks, and drive bay population. All are necessary to provide and regulate the airflow and air pressure needed to maintain the system's thermals when operating at or below maximum specified thermal limits.

The system has a redundant system cooling configuration consisting of five 40x40x56-mm dual-rotor system fans. This configuration provides sufficient airflow to maintain internal system thermal requirements when a single fan rotor fails and when the external ambient temperature remains within specified limits. The fans are not hot-swappable and the system must be shut down in order to replace a failed fan.

In addition to the system fans, each installed power supply module provides an additional 56-mm dual-rotor fan, which pulls air from inside the system and blows it out the back.

The system utilizes an integrated platform control mechanism to manage a variable fan speed control engine to provide adequate cooling for the system. If a fan fails, the Integrated BMC boosts the remaining fans as a means to compensate for the lost airflow. If the cooling is not sufficient under a failed fan condition, the system eventually shuts down to protect itself from thermal damage. Additionally, this fan boost causes additional vibration in this system. Some hard drives are very susceptible to vibration. For additional details, see Section 4.5.

4.1 Fan Module

The system fan module houses five 40x40x56-mm dual-rotor system fans. The module has been designed for ease of use and has support for several management features that can be utilized by the Integrated Baseboard Management Controller. The system fan module and individual dual-rotor fans do not require tools for installation or removal.

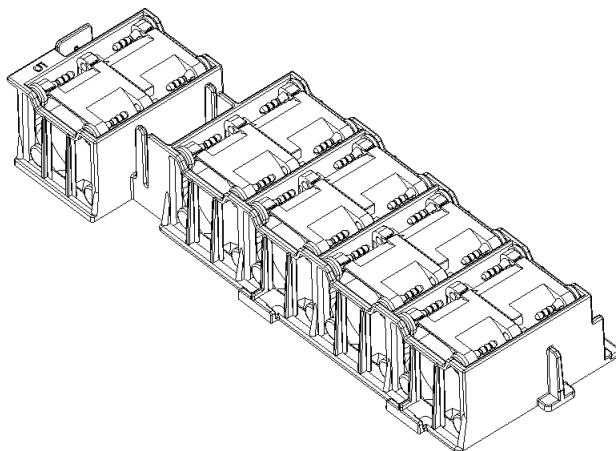

Figure 16. Fan Module

The individual system fans are not hot-swappable and require the system to be turned off before being replaced. The chassis is classified as a “Service Access Only” device and caution should be exercised when replacing a system fan, as they do not have finger guards. However, provisions are built into the fan bracket to prevent accidental contact with the fan rotors. Each fan within the module is capable of supporting multiple speeds. If the internal ambient temperature of the system exceeds the value programmed into the thermal sensor data record (SDR), the Integrated BMC firmware increases the speed for all the fans within the fan module.

Each fan connector within the module supplies two tachometer signals (one for each fan rotor) allowing the Integrated Baseboard Management Controller to monitor the status of each fan rotor. If a fan fails, the remaining fans increase their rotation and attempt to maintain the thermal requirements of the system.

Each system fan has an associated fan fault LED located next to its fan cable connector on the midplane board. The fan fault LED is controlled by the Integrated BMC. If a fan rotor within a system fan fails, it illuminates the fan fault LED and logs the failure into the System Event Log.

Table 20. Fan Connector Pin Assingment

Pin	Signal Name	Description
1	Tachometer B	Fan RPM sensor output
2	PWM	Fan speed control signal
3	12 V	Power for fan
4	12 V	Power for fan
5	Tachometer A	Fan RPM sensor output
6	Return	Return path to ground
7	Return	Return path to ground
8	Fan Presence	Detection if fan is installed in system
9	LED Cathode	Loopback signal to pin 10
10	LED Anode	Loopback signal to pin 9

The system fan cables plug into the connectors on the midplane board as shown in the following figure. Both passive and active midplanes have the same fan numbering and fan connector locations.

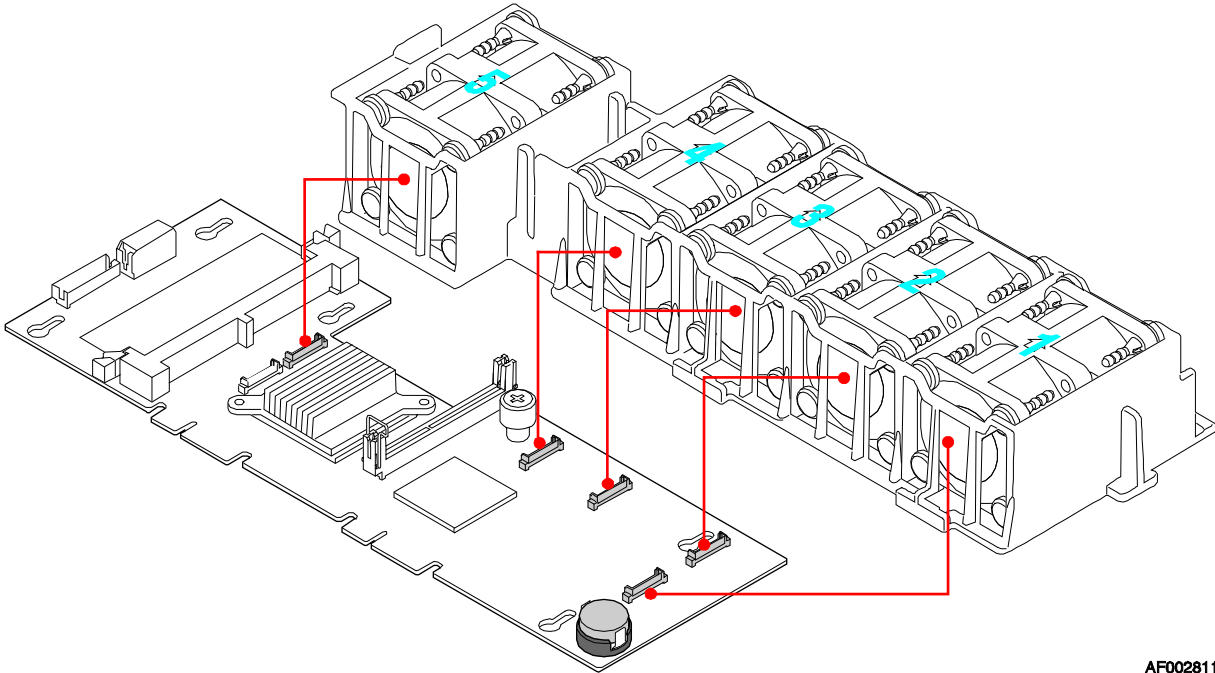

AF002811

Figure 17. Fan Header Assignments on Midplane

Table 21. Fan Header Assignment

Fan ID	Midplane Fan Header Name
Fan #1 – CPU2/System memory cooling	FAN_1
Fan #2 – CPU2/System memory cooling	FAN_2
Fan #3 – CPU1/System Memory cooling	FAN_3
Fan #4 – CPU1/System Memory cooling	FAN_4
Fan #5 - Full-height Riser Zone cooling	FAN_5

4.2 Airflow Support

To control airflow within the system, a power supply air duct and CPU air duct are used to isolate and direct airflow to three critical areas or zones: the power supply zone, the full-height PCI zone, and the CPU/memory/low-profile PCI zone.

4.2.1 Power Supply Zone

A molded plastic air duct/baffle is used to isolate the airflow of the main system board zones from the zone directly in front of the power supply modules. The power supply fans pull pre-heated air from the leftmost drive bays across the Power Distribution Board to cool its voltage regulators.

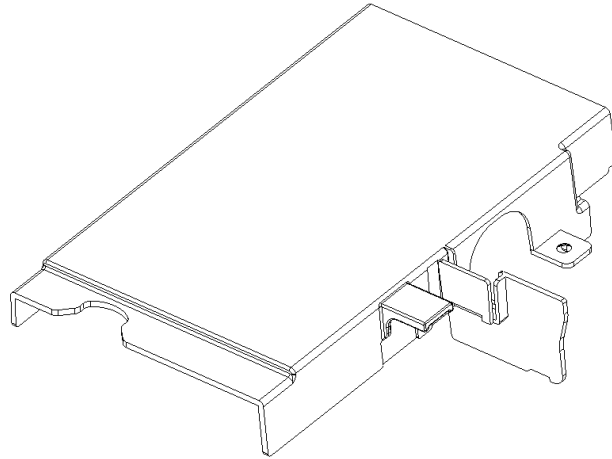

Figure 18. Power Supply Air Duct

4.2.2 PCI Riser Zone

The PCI riser zone is the area between the power supply assembly and the PCI riser card of the riser assembly. The airflow through this area is generated by Fan 5 of the fan module. Air is drawn from the drive bay area through the fan and pushed out of the system through ventilation holes at the back of the chassis.

4.2.3 CPU/Memory

The CPU/memory zone is the area between the PCI riser card of the riser assembly and the right chassis wall. The airflow for this zone is generated by system fans 1, 2, 3, and 4 of the fan module. Air is drawn from the drive bay area, through the fans, directed through the CPU air duct, and out through ventilation holes on both the back wall and rear side wall of the chassis.

An air duct is used to direct airflow through the processor heatsinks for both single and dual processor configurations.

Note: The air baffle should ONLY be removed when a second processor is installed. Operating a single processor configuration with the air baffle removed may overheat the processor and may cause the system to shut down.

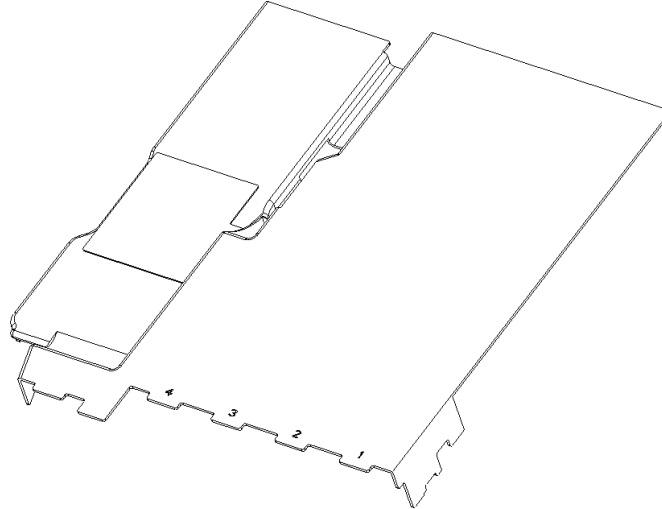
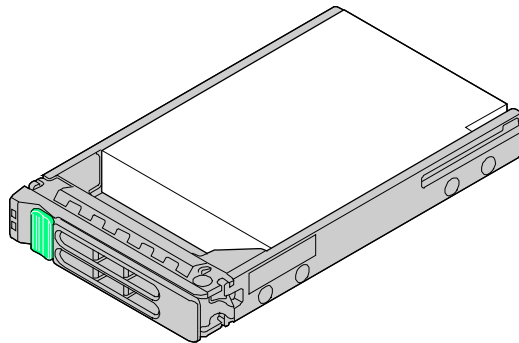

Figure 19. Air Duct

4.3 Drive Bay Population

To maintain the proper air pressure within the system, all hard drive bays must be populated with either a hard drive, or drive blank.



AF002779

Figure 20. 2.5 inch Drive Blank

4.4 Sata HDD Support

Due to the rotational velocity and vibration impacts that fans have on hard drives, fan redundancy is only supported when using SAS hard drives. Additionally the maximum supported temperatures when using SATA drives have been affected as follows:

- At 1500 m (5000 ft), the maximum ambient temperature is 30°C.
- At 900 m (3000 ft), the maximum ambient temperature is 35°C.

5. System Board Interconnects

System boards within the system include two types of midplanes, a bridge board, a hard drive backplane, a PCI riser board, and three types of control panels. This chapter describes the interconnect features of each and defines the pin-outs for each of their connectors. Functional details of each system board are described in later chapters.

5.1 Midplane

The midplane is designed and used, along with that of the bridge board and hot-swap backplane, to improve cable routing within the system. The midplane is the key system board of the system. It serves as the primary interface between the server board, hot-swap backplane, and control panel. Two midplanes are offered for this system: a passive SATA/SAS, and an active SAS/SAS RAID.

The passive midplane is a simple pass through from the backplane to the SATA connectors on the server board or SAS/SATA connectors on an add-in card.

The following diagram shows the location for each connector found on the passive midplane board:

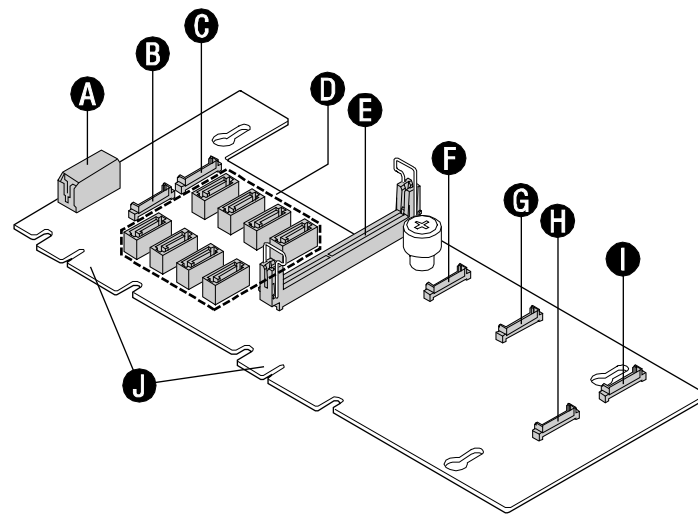

AF000047

A	Power Connector	F	Fan 4 Connector
B	Fan 6 Connector	G	Fan 3 Connector
C	Fan 5 Connector	H	Fan 1 Connector
D	SAS/SATA Connectors	I	Fan 2 Connector
E	Bridge Board Connector	J	Backplane Connector

Figure 21. Passive Midplane Board

The system also supports an active SAS/SAS RAID midplane. This system board incorporates an LSI LSISAS1078 SAS controller onto the board. For information about SAS/SAS RAID support, see Chapter 6. The following figure shows the location for each connector found on this board.

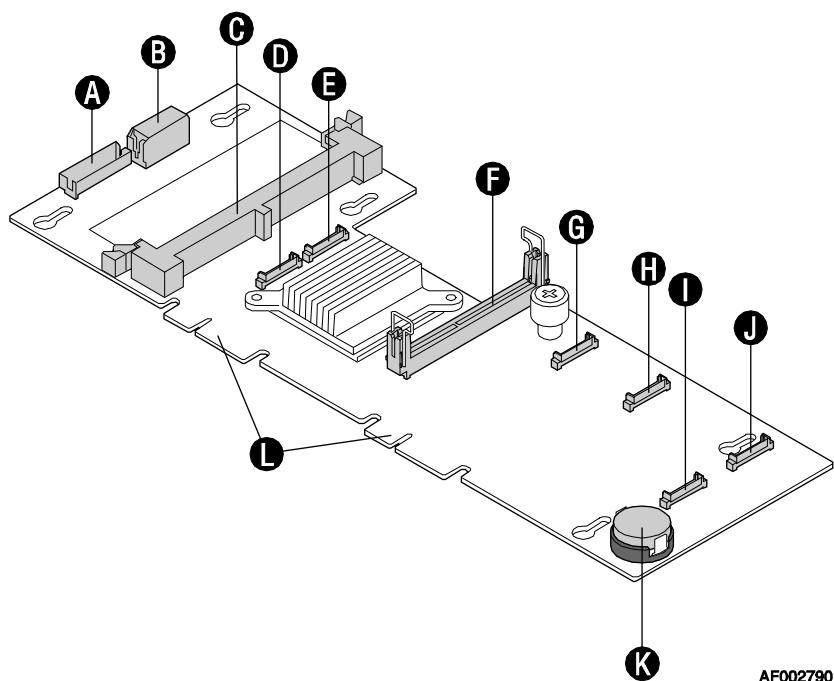

A	Optional RAID Cache Battery Backup Connection	G	Fan 4 Connector
B	Power Connector	H	Fan 3 Connector
C	Mini-DIMM Connector	I	Fan 1 Connector
D	Fan 6 Connector	J	Fan 2 Connector
E	Fan 5 Connector	K	RAID Activation Key Connector
F	Bridge Board Connector	L	Backplane Connector

Figure 22. SAS/SAS RAID Midplane Board

Note: A continuous beep sound may be experienced when the SAS controller is disabled in BIOS. As a workaround, enable the SAS controller in BIOS.

The following tables define the connector pin-outs for both midplane boards:

Table 22. 120-pin Server Board-to-Midplane Bridge Board Connector Pin-out

Pin	Signal Name	Pin	Signal Name
1	GND	61	SMB_SENSOR_3V3SB_CLK_BUF
2	PE1_ESB_TX_DN3	62	SMB_SENSOR_3V3SB_DAT_BUF
3	PE1_ESB_TX_DP3	63	FM_BRIDGE_PRSNT_N
4	GND	64	GND

Pin	Signal Name	Pin	Signal Name
5	PE_WAKE_N	65	PE1_ESB_RX_DN_C3
6	GND	66	PE1_ESB_RX_DP_C3
7	PE1_ESB_TX_DN2	67	GND
8	PE1_ESB_TX_DP2	68	FAN_PRSNT6_N
9	GND	69	GND
10	FAN_PRSNT5_N	70	PE1_ESB_RX_DN_C2
11	GND	71	PE1_ESB_RX_DP_C2
12	PE1_ESB_TX_DN1	72	GND
13	PE1_ESB_TX_DP1	73	FAN_PRSNT4_N
14	GND	74	GND
15	RST_PS_PWRGD	75	PE1_ESB_RX_DN_C1
16	GND	76	PE1_ESB_RX_DP_C1
17	PE1_ESB_TX_DN0	77	GND
18	PE1_ESB_TX_DP0	78	RAID_KEY_PRES
19	GND	79	GND
20	FM_RAID_MODE	80	PE1_ESB_RX_DN_C0
21	GND	81	PE1_ESB_RX_DP_C0
22	CLK_IOP_DN	82	GND
23	CLK_IOP_DP	83	FAN_PRSNT1_N
24	GND	84	FAN_PRSNT3_N
25	SGPIO_DATAOUT1	85	FAN_PRSNT2_N
26	SGPIO_DATAOUT0	86	GND
27	SGPIO_LOAD	87	USB1_ESB_DP
28	SGPIO_CLOCK	88	USB1_ESB_DN
29	GND	89	GND
30	USB2_ESB_DP	90	USB1_ESB_OC_N
31	USB2_ESB_DN	91	USB0_ESB_OC_N
32	GND	92	GND
33	USB2_ESB_OC_N	93	USB0_ESB_DP
34	NIC1_LINK_LED_N	94	USB0_ESB_DN
35	NIC1_ACT_LED_N	95	GND
36	LED_STATUS_AMBER_R1	96	FP_NMI_BTN_N
37	NIC2_LINK_LED_N	97	BMC_RST_BTN_N
38	NIC2_ACT_LED_N	98	FP_PWR_BTN_N
39	LED_STATUS_GREEN_BUF_R1	99	FP_ID_SW_L
40	GND	100	GND
41	SMB_PBI_5VSB_DAT	101	SMB_IPMB_5VSB_DAT
42	SMB_PBI_5VSB_CLK	102	SMB_IPMB_5VSB_CLK
43	GND	103	GND
44	V_IO_HSYNC2_BUF_FP	104	LED_HDD_ACTIVITY_N
45	V_IO_VSYNC2_BUF_FP	105	LED_HDD_5V_A
46	GND	106	FP_PWR_LED_R_N
47	V_IO_BLUE_CONN_FP	107	FP_PWR_LED_3VSB
48	V_IO_GREEN_CONN_FP	108	FP_ID_LED_R1_N
49	V_IO_RED_CONN_FP	109	FM_SIO_TEMP_SENSOR
50	GND	110	LED_FAN3_FAULT
51	LED_FAN6_FAULT	111	LED_FAN2_FAULT
52	LED_FAN5_FAULT	112	LED_FAN1_FAULT

Pin	Signal Name	Pin	Signal Name
53	LED_FAN4_FAULT	113	FAN_PWM_CPU1
54	FAN_PWM3	114	GND
55	GND	115	FAN_PWM_CPU2
56	PCI_FAN_TACH10	116	PCI_FAN_TACH9
57	FAN_TACH8	117	FAN_TACH7
58	FAN_TACH6	118	FAN_TACH5
59	FAN_TACH4_H7	119	FAN_TACH3_H7
60	FAN_TACH2_H7	120	FAN_TACH1_H7

Table 23. Midplane Fan Header Pin-outs

J2B1 - FAN_1		J2B3 - FAN_3		J7B1 - FAN_5	
Pin	Signal Name	Pin	Signal Name	Pin	Signal Name
1	FAN_TACH5	1	FAN_TACH7	1	FAN_TACH10
2	FAN_PWM_CPU1	2	FAN_PWM_CPU2	2	FAN_PWM3
3	P12V	3	P12V	3	P12V
4	P12V	4	P12V	4	P12V
5	FAN_TACH1_H7	5	FAN_TACH3_H7	5	FAN_TACH9
6	GND	6	GND	6	GND
7	GND	7	GND	7	GND
8	FAN_PRSNT1_N	8	FAN_PRSNT3_N	8	FAN_PRSNT5_N
9	LED_FAN1_FAULT	9	LED_FAN3_FAULT	9	LED_FAN5_FAULT
10	LED_FAN1	10	LED_FAN3	10	LED_FAN5

J2B2 - FAN_2		J3B1 - FAN_4		J7B2 - FAN_6	
Pin	Signal Name	PIN	Signal Name	Pin	Signal Name
1	FAN_TACH6	1	FAN_TACH8	1	UNUSED
2	FAN_PWM_CPU1	2	FAN_PWM_CPU2	2	FAN_PWM3
3	P12V	3	P12V	3	P12V
4	P12V	4	P12V	4	P12V
5	FAN_TACH2_H7	5	FAN_TACH4_H7	5	FAN_TACH10
6	GND	6	GND	6	GND
7	GND	7	GND	7	GND
8	FAN_PRSNT2_N	8	FAN_PRSNT4_N	8	FAN_PRSNT6_N
9	LED_FAN2_FAULT	9	LED_FAN4_FAULT	9	LED_FAN6_FAULT
10	LED_FAN2	10	LED_FAN4	10	LED_FAN6

Table 24. Midplane Power Connector Pin-out

Pin	Signal Description
1	GND
2	GND
3	P5V
4	P3V3
5	GND
6	P12V
7	P12V
8	P12V
9	P12V

Pin	Signal Description
10	P5V_STBY

Table 25. Midplane-to-Backplane Card Edge Connector #1 Pin-out

J7A1 - HSBP#1 I/F			
Pin	Signal Name	Pin	Signal Name
A1	RST_PS_PWRGD	B1	GND
A2	GND	B2	SATA0_RX_N
A3	GND	B3	SATA0_RX_P
A4	SATA1_RX_N	B4	GND
A5	SATA1_RX_P	B5	GND
A6	GND	B6	SATA0_TX_N
A7	GND	B7	SATA0_TX_P
A8	SATA1_TX_P	B8	GND
A9	SATA1_TX_N	B9	GND
A10	GND	B10	USB2_ESB_DN
A11	GND	B11	USB2_ESB_DP
A12	USB2_ESB_OC_N	B12	GND
A13	GND	B13	SATA2_RX_N
A14	GND	B14	SATA2_RX_P
A15	SATA3_RX_N	B15	GND
A16	SATA3_RX_P	B16	NC_RESERVEDB16
A17	GND	B17	SMB_SAS_EDGE_DAT
A18	GND	B18	NC_RESERVEDB18
A19	GND	B19	SMB_SAS_EDGE_CLK
A20	SATA3_TX_P	B20	NC_RESERVEDB20
A21	SATA3_TX_N	B21	GND
A22	GND	B22	SATA2_TX_P
A23	GND	B23	SATA2_TX_N
A24	SATA5_RX_N	B24	GND
A25	SATA5_RX_P	B25	GND
A26	GND	B26	SATA4_RX_N
A27	GND	B27	SATA4_RX_P
A28	SATA5_TX_P	B28	GND
A29	SATA5_TX_N	B29	GND
A30	GND	B30	SATA4_TX_P
A31	GND	B31	SATA4_TX_N
A32	P5V_STBY	B32	GND

Table 26. Midplane-to-Backplane Card Edge Connector #2 Pin-out

J4A1 - HSBP#2 I/F			
Pin	Signal Name	Pin	Signal Name
A1	SGPIO_DATAOUT0	B1	SGPIO_CLOCK
A2	SGPIO_DATAOUT1	B2	GND
A3	GND	B3	SATA_ADDIN1_RX_N

J4A1 - HSBP#2 I/F			
A4	GND	B4	SATA_ADDIN1_RX_P
A5	SATA_ADDIN2_RX_N	B5	GND
A6	SATA_ADDIN2_RX_P	B6	GND
A7	GND	B7	SATA_ADDIN1_TX_N
A8	GND	B8	SATA_ADDIN1_TX_P
A9	SATA_ADDIN2_TX_P	B9	GND
A10	SATA_ADDIN2_TX_N	B10	GND
A11	GND	B11	SGPIO_LOAD
A12	SMB_PBI_3VSB_DAT	B12	SMB_IPMB_5VSB_DAT
A13	SMB_PBI_3VSB_CLK	B13	SMB_IPMB_5VSB_CLK
A14	USB0_ESB_OC_N	B14	GND
A15	GND	B15	USB1_ESB_DP
A16	GND	B16	USB1_ESB_DN
A17	USB0_ESB_DP	B17	GND
A18	USB0_ESB_DN	B18	GND
A19	GND	B19	USB1_ESB_OC_N
A20	LED_NIC1_ACT_N	B20	LED_HDD_ACTIVITY_N
A21	LED_NIC1_LINK_N	B21	LED_HDD_5V_A
A22	FM_SIO_TEMP_SENSOR	B22	FP_ID_SW_L
A23	LED_NIC2_LINK_N	B23	BMC_RST_BTN_N
A24	LED_NIC2_ACT_N	B24	FP_PWR_BTN_N
A25	GND	B25	FP_NMI_BTN_N
A26	V_BLUE_CONN_FP	B26	FP_PWR_LED_3VSB
A27	V_GREEN_CONN_FP	B27	FP_PWR_LED_R_N
A28	V_RED_CONN_FP	B28	FP_ID_LED_R1_N
A29	GND	B29	GND
A30	V_HSYNC2_BUF_FP	B30	LED_STATUS_AMBER_R1
A31	V_VSYNC2_BUF_FP	B31	LED_STATUS_GREEN_BUF_R1
A32	GND	B32	FP_LED

Table 27. Active Midplane SAS RAID Battery Backup Connector Pin-out

Pin	Signal Description
1	P12V
2	GND
3	NC_P5V_MONITOR
4	GND
5	P1V8_VBAT_RAID
6	GND
7	PWRGD_P3V3_STBY
8	GND
9	P1V8_VBAT_RAID
10	GND
11	PX_RESET_N
12	GND
13	SMB_CLK_P3V3
14	GND
15	SMB_DAT_P3V3

Pin	Signal Description
16	BBU_PFAIL_N
17	BBU_DDR_SEL
18	BBU_BBE
19	BBU_BBSTROBE
20	BBU_BBSTATUS

Table 28. Passive Midplane SATA/SAS Connector Pin-outs

J5A2 - SAS_7		J6A1 - SAS_6		J5B1 - SAS_4		J6B1 - SAS_2	
Pin	Signal Name	Pin	Signal Name	Pin	Signal Name	Pin	Signal Name
1	GND	1	GND	1	GND	1	GND
2	SATA_ADDIN1_TX_P	2	SATA5_TX_P	2	SATA3_TX_P	2	SATA1_TX_P
3	SATA_ADDIN1_TX_N	3	SATA5_TX_N	3	SATA3_TX_N	3	SATA1_TX_N
4	GND	4	GND	4	GND	4	GND
5	SATA_ADDIN1_RX_N	5	SATA5_RX_N	5	SATA3_RX_N	5	SATA1_RX_N
6	SATA_ADDIN1_RX_P	6	SATA5_RX_P	6	SATA3_RX_P	6	SATA1_RX_P
7	GND	7	GND	7	GND	7	GND

J5A1 - SAS_8		J6A2 - SAS_5		J5B2 - SAS_3		J6B2 - SAS_1	
Pin	Signal Name	Pin	Signal Name	Pin	Signal Name	Pin	Signal Name
1	GND	1	GND	1	GND	1	GND
2	SATA_ADDIN2_TX_P	2	SATA4_TX_P	2	SATA2_TX_P	2	SATA0_TX_P
3	SATA_ADDIN2_TX_N	3	SATA4_TX_N	3	SATA2_TX_N	3	SATA0_TX_N
4	GND	4	GND	4	GND	4	GND
5	SATA_ADDIN2_RX_N	5	SATA4_RX_N	5	SATA2_RX_N	5	SATA0_RX_N
6	SATA_ADDIN2_RX_P	6	SATA4_RX_P	6	SATA2_RX_P	6	SATA0_RX_P
7	GND	7	GND	7	GND	7	GND

5.2 Bridge Board

The system utilizes a bridge board to route signals from the server board to the midplane board. The bridge board carries signals for three USB ports, SSI front panel control signals, video, various I²C buses, fan control signals, and a PCI Express* x4 bus for SAS controller function. For details, see Table 22.

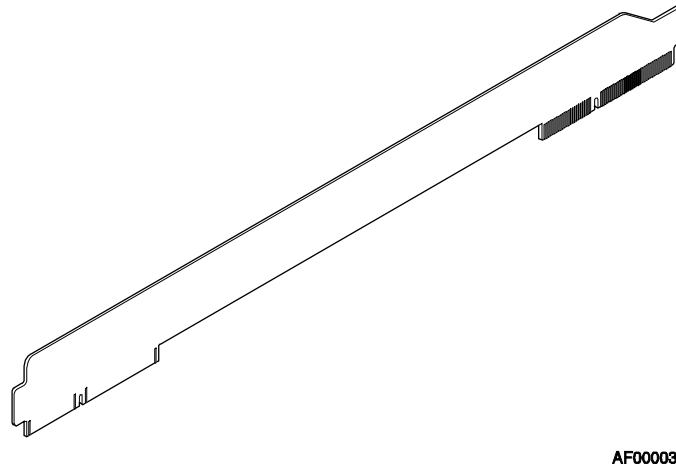
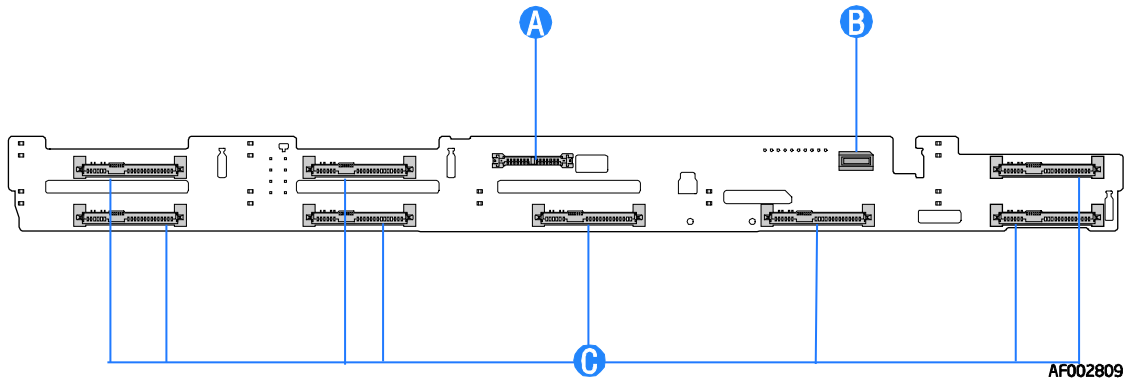

Figure 23. Bridge Board

5.3 Hot-Swap SATA/SAS Backplane

The hot-swap backplane provides support for both SAS and SATA hard drives. There are no hard drive cables that connect to the backplane. All hard drive control signals are routed from the midplane board, which plugs directly into the backplane.



A	Slimline Optical Device Connector	C	SAS/SATA hot-swap Connectors
B	Mini Control Panel Connector		

Figure 24. Hot-Swap SAS/SATA Backplane (Front Side View)

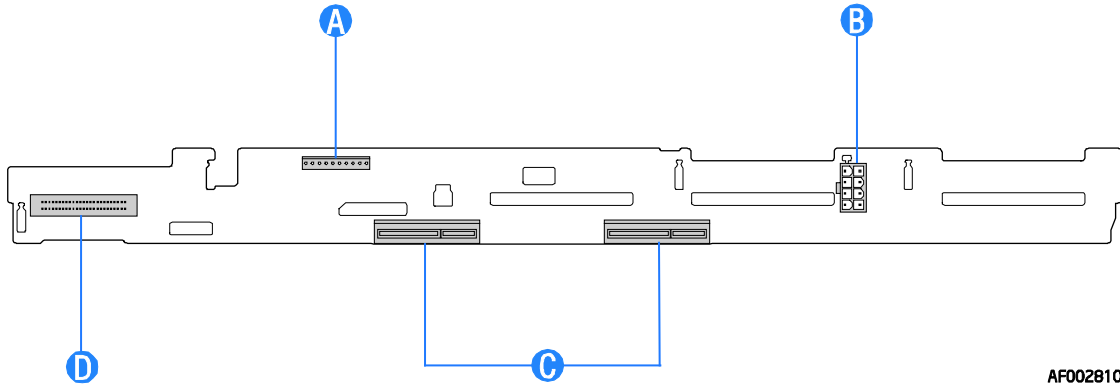

AF002810

A	USB Connector	C	Card Edge Connectors to Midplane
B	Power Connector	D	10-pin Control Panel Connector

Figure 25. Hot-Swap SAS/SATA Backplane (Back Side View)

Table 29. 2x4 SAS/SATA Backplane Power Connector Pin-out

Pin #	Signal Name
1	Ground
2	Ground
3	P5V
4	P5V
5	P12V
6	P12V
7	P5V_STBY
8	P3V3

Table 30. 1x7 Tape Drive Option Power Connector Pin-out (J2N2)

Pin #	Signal Name
1	P12V
2	Ground
3	Ground
4	P5V
5	SASS_PRSTNT_L
6	LED_SASS_ACT_L
7	P3V3

Table 31. Slimline Optical Drive Slot Connector (J6C1)

Pin #	Signal Name
S1	GND
S2	SATA_TXP
S3	SATA_TXN
S4	GND
S5	SATA_RXN
S6	SATA_RXP
S7	GND

KEY	
P1	N/C
P2	P5V
P3	P5V
P4	N/C
P5	GND
P6	GND

Table 32. I²C Connector

Pin #	Signal Description
1	SMB_VSC_12C_DAT0
2	GROUND
3	SMB_VSC_12C_CLK0
4	Not Used

Table 33. PCI Express* x4 Slot Connector from Midplane

Pin #	Signal Name	Pin #	Signal Name
A1	SGPIO_DATA0	B1	SGPIO_CLOCK
A2	SGPIO_DATA1	B2	Ground
A3	Ground	B3	SAS6_RX_DN
A4	Ground	B4	SAS6_RX_DP
A5	SAS7_RX_DN	B5	Ground
A6	SAS7_RX_DP	B6	Ground
A7	Ground	B7	SAS6_TX_DN
A8	Ground	B8	SAS6_TX_DP
A9	SAS7_TX_DP	B9	Ground
A10	SAS7_TX_DN	B10	Ground
A11	Ground	B11	SGPIO_LOAD
A12	SMB_PB1_5VSB_DAT	B12	SMB_IPMB_5VSB_DAT
A13	SMB_PB1_5VSB_CLK	B13	SMB_IPMB_5VSB_CLK
A14	USB_OC1_N	B14	Ground
A15	Ground	B15	USB_P2P
A16	Ground	B16	USB_P2N
A17	USB_P1P	B17	Ground
A18	USB_P1N	B18	Ground
A19	Ground	B19	USB_OC2_N
A20	LED_NIC1_ACT_L	B20	LED_HDD_ACT_R_L
A21	LED_NIC1_LINK_R_L	B21	PV_HDD_LED_3V_A
A22	FP_THERM_SENSOR	B22	FP_ID_SW_L
A23	LED_NIC2_LINK_R_L	B23	RST_FP_BTN_L
A24	LED_NIC2_ACT_L	B24	FP_PWR_BTN_L
A25	Ground	B25	FP_NMI_BTN_L
A26	V_IO_BLUE_CONN_FP	B26	FP_PWR_LED_5VSB
A27	V_IO_GREEN_CONN_FP	B27	LED_FP_PWR_R_L
A28	V_IO_RED_CONN_FP	B28	LED_FP_ID_R_L
A29	Ground	B29	Ground
A30	V_IO_HSYNC_BUFF_FP_L	B30	LED_FP_SYS_FLT1_R_L
A31	V_IO_VSYNC_BUFF_FP_L	B31	LED_FP_SYS_FLT2_R_L
A32	Ground	B32	FP_FLT_LED_5VSB

Table 34. PCI Express* x4 Slot Connector from Midplane

Pin #	Signal Name	Pin #	Signal Name
A1	RST_PWRGD_PS	B1	Ground

A2	Ground	B2	SAS0_RX_DN
A3	Ground	B3	SAS0_RX_DP
A4	SAS1_RX_DN	B4	Ground
A5	SAS1_RX_DP	B5	Ground
A6	Ground	B6	SAS0_TX_DN
A7	Ground	B7	SAS0_TX_DP
A8	SAS1_TX_DP	B8	Ground
A9	SAS1_TX_DN	B9	Ground
A10	Ground	B10	USB_P3N
A11	Ground	B11	USB_P3P
A12	USB_OC3_N	B12	Ground
A13	Ground	B13	SAS2_RX_DN
A14	Ground	B14	SAS2_RX_DP
A15	SAS3_RX_DN	B15	Ground
A16	SAS3_RX_DP	B16	Not Used
A17	Ground	B17	SMB_SAS_3V3_SDA
A18	Ground	B18	Not Used
A19	Ground	B19	SMB_SAS_3V3_SCL
A20	SAS3_TX_DP	B20	Not Used
A21	SAS3_RT_DN	B21	Ground
A22	Ground	B22	SAS2_TX_DP
A23	Ground	B23	SAS2_TX_DN
A24	SAS5_RX_DN	B24	Ground
A25	SAS5_RX_DP	B25	Ground
A26	Ground	B26	SAS4_RX_DN
A27	Ground	B27	SAS4_RX_DP
A28	SAS5_TX_DP	B28	Ground
A29	SAS5_TX_DN	B29	Ground
A30	Ground	B30	SAS4_TX_DP
A31	Ground	B31	SAS4_TX_DN
A32	P5V_STBY	B32	Ground

Table 35. Intel® Local Control Panel (LCP) Connector

Pin #	Signal Description
1	SMB_IPMB_5VSB_DAT
2	Ground
3	SMB_IPMB_5VSB_CLK
4	P5V_STBY_R

Table 36. Control Panel Signal Connector

Pin #	Signal Name	Pin #	Signal Name
1	V_IO_RED_CONN_FP	2	GND
3	V_IO_GREEN_CONN_FP	4	GND
5	V_IO_BLUE_CONN_FP	6	GND
7	V_IO_HSYNC_BUFF_FP_L	8	GND
9	V_IO_VSYNC_BUFF_FP_L	10	GND
11	V_VIDEO_IN_USE	12	FP_THERM_SENSOR
13	SP_DTR2_L	14	SP_DCD2_L
15	SP_RTS2_L	16	SP_CTS2_L
17	SP_SIN2	18	SP_SOUT2
19	SP_DSR2_L	20	SP_IN_USE
21	FP_NMI_BTN_L	22	GND
23	LED_NIC1_ACT_L	24	LED_NIC1_LINK_R_L
25	Not Used	26	FP_CHASSIS_INTRU
27	FP_ID_SW_L	28	SMB_PB1_5VSB_CLK
29	GND	30	SMB_PB1_5VSB_DAT
31	RST_FP_BTN_L	32	LED_NIC2_ACT_L
33	LED_HDD_FLT_R_L	34	LED_NIC2_LINK_R_L
35	FP_PWR_BTN_L	36	LED_FP_ID_R_L
37	SMB_IPMB_5VSB_CLK	38	GND
39	SMB_IPMB_5VSB_DAT	40	PV_HDD_LED_3V_A
41	LED_FP_PWR_R_L	42	FP_FLT_LED_5VSB
43	FP_PWR_LED_5VSB	44	LED_FP_SYS_FLT2_R_L
45	RST_PWRGD_PS	46	LED_FP_SYS_FLT1_R_L
47	LED_HDD_ACT_RR_L	48	P5V
49	P5V_STBY	50	P5V_STBY

Table 37. Control Panel USB Connector

Pin #	Signal Description
1	P5V_USB_P1
2	USB_P1N
3	USB_P1P
4	GND
5	GND
6	P5V_USB_P2
7	USB_P2N
8	USB_P2P
9	GND
10	GND

Table 38. SAS/SATA Hard Drive Connector Pin-outs

Pin#	Signal Description
S1	Ground
S2	SAS#_TX_DP (# = 0...7)
S3	SAS#_TX_DN (# = 0...7)
S4	Ground
S5	SAS#_RX_DN (# = 0...7)
S6	SAS#_RX_DP (# = 0...7)
S7	Ground
S8	Not Used
S9	Not Used
S10	Not Used
S11	Not Used
S12	Not Used
S13	Not Used
S14	Not Used
P1	Not Used
P2	Not Used
P3	Not Used
P4	Ground
P5	Ground
P6	P3V3
P7	P5V
P8	P5V
P9	P5V
P10	Ground
P11	LED_SAS#_ACT_L (# = 0...7)
P12	Ground
P13	P12V
P14	P12V
P15	P12V
PTH0	Ground
PTY1	Ground

6. Peripheral Drive Support

The system provides a slimline drive bay that can be populated with an SATA optical drive (CD-ROM, DVD, DVD/CDR). Drives are mounted on a tool-less tray which allows for easy installation into and removal from the system. The slim-line devices are not hot-swappable.

6.1 Optical Drive Support

The system provides a slimline drive bay that is designed to support a single slimline SATA optical drive. For a list of supported drives, use the Server Configurator Tool available at <http://serverconfigurator.intel.com/default.aspx>.

The optical drive type is mounted to a tool-less assembly latch that allows for easy installation and fixation in the system. Once it is inserted into the system, the assembly locks into place. It is not hot-swappable. For removal, the system must be powered down, the chassis top cover removed and the locking latch disengaged. For additional details, see the *Intel® Server System SR1625UR Service Guide*.

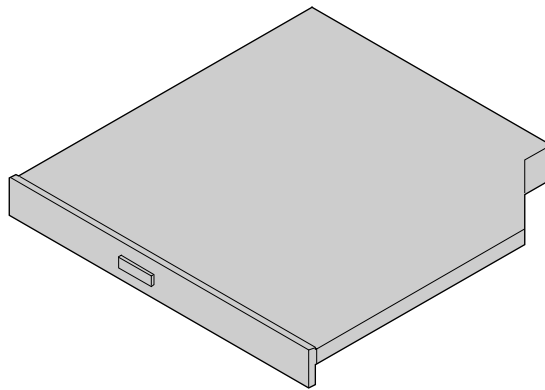

AF002777

Figure 26. Slimline Optical Drive Assembly

The SATA Optical drive plugs directly into the backplane, using industry standard 13-pin SATA connector. This SATA channel is routed from USB to SATA converter, located on the backplane. The optical drive is seen as a USB device in the system.

Table 39. Slimline Optical Drive Slot Connector (J6C1)

Pin #	Signal Name
S1	GND
S2	SATA_TXP
S3	SATA_TXN
S4	GND
S5	SATA_RXN
S6	SATA_RXP
S7	GND

Pin #	Signal Name
KEY	
P1	N/C
P2	P5V
P3	P5V
P4	N/C
P5	GND
P6	GND

7. Hard Disk Drive Support

The system can be configured to support several different hard drive and peripheral configurations. The peripheral/hard drive subsystem consists of a drive bay supporting a slimline optical drive, and hard drives; a midplane; and a hot-swap backplane. This chapter describes the details for each subsystem component.

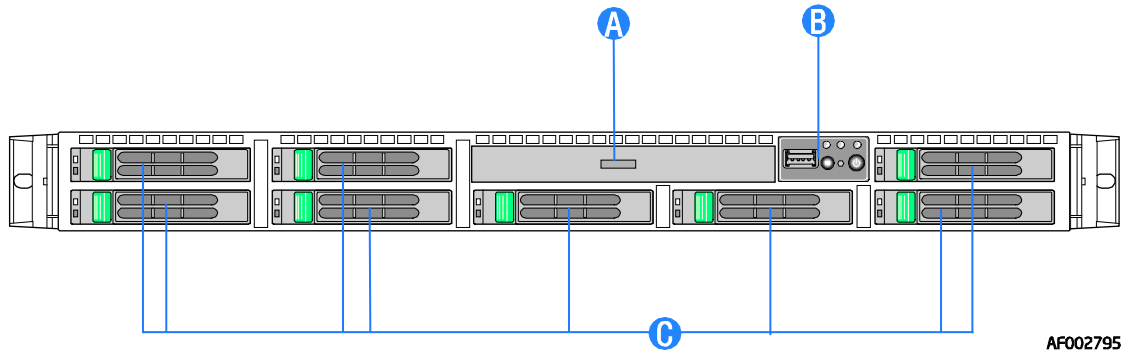

A	Slimline SATA Optical Drive Bay
B	Mini Control Panel
C	2.5 inch Hard Drive Bays (Up to eight possible with mini control panel)

Figure 27. Mini Control Panel with Eight Hard Drives (Front View)

7.1 Hard Drive Bays

The system can be configured to support up to eight hot-swap 2.5 inch SAS or SATA hard disk drives. The hard drives are mounted to hot-swap drive trays for easy insertion or extraction from the drive bay.

7.1.1 Hot-swap Drive Trays

Each hard drive must be mounted to a hot-swap drive tray, making insertion and extraction of the drive from the system very simple. Each drive tray has its own dual purpose latching mechanism that is used to insert and extract drives from the system, and lock the tray assembly in place. Each drive tray supports two light pipes viewable from the front of the system. The light pipes provide a green drive activity indicator and amber drive fault indicator. The drive activity and fault LEDs are located on the backplane next to each drive connector.

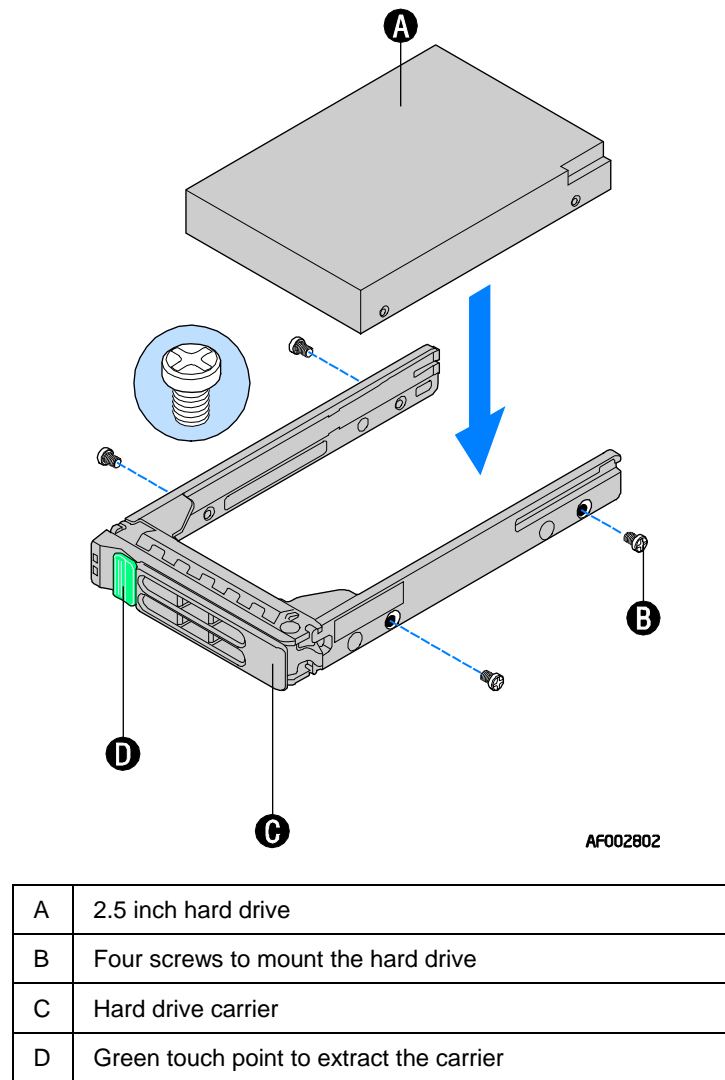

Figure 28. Hard Drive Tray Assembly

7.2 Midplane Options

The midplane is designed and used, along with that of the bridge board and hot-swap backplane, to improve cable routing within the system. The midplane is the key system board of the system. It serves as a primary interface between the server board, hot-swap backplane, and control panel. Two midplanes are offered for this system: a passive SATA/SAS, and an active SAS/SAS RAID.

7.2.1 Passive Midplane

The passive midplane is used as an interconnect, routing drive control signals from either the on-board SATA ports of the server board or SAS/SATA ports from an add-in card to the hot-swap backplane. The hard drive controller signals are cabled to the midplane, which then routes the signals to the hot-swap backplane through two edge connectors that plug directly into it.

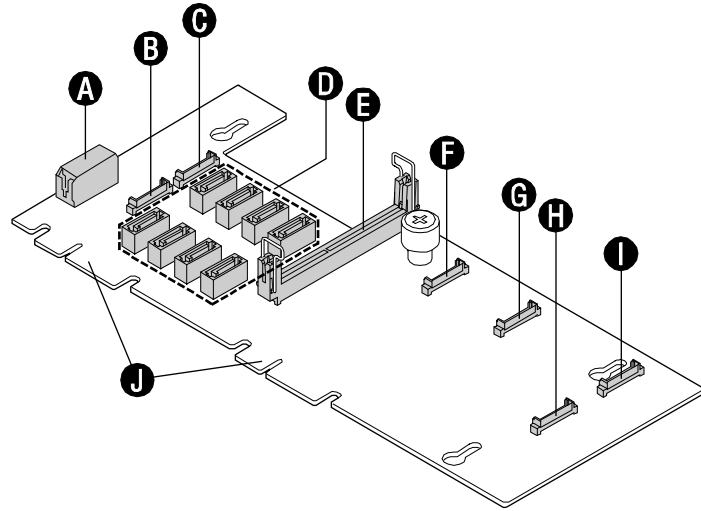

AF000047

A.	Power Connector	F.	Fan 4 Connector
B.	Fan 6 Connector	G.	Fan 3 Connector
C.	Fan 5 Connector	H.	Fan 1 Connector
D.	SAS/SATA Connectors	I.	Fan 2 Connector
E.	Bridge Board Connector	J.	Backplane Connector

Figure 29. Passive Midplane Board

7.2.2 Active Midplane with Intel® SAS /SAS RAID Support

The active midplane is used to provide SAS/SAS RAID support. It has an integrated LSI LSL SAS1078 3 Gb/s RAID On-a-Chip (ROC) device. It provides support for up to eight SAS drives in this system. By default, this midplane option provides software RAID levels 0, 1, and 10 and utilizes Intel® IT/IR RAID. With the installation of optional RAID enablement devices, the midplane can support hardware RAID levels 0, 1, 5, 10, 50, 6 and 60. The midplane attaches to the hot-swap backplane by two card edge connectors, which eliminates the need for any hard drive cables. The following sub-sections describe the board level SAS/SAS RAID functionality.

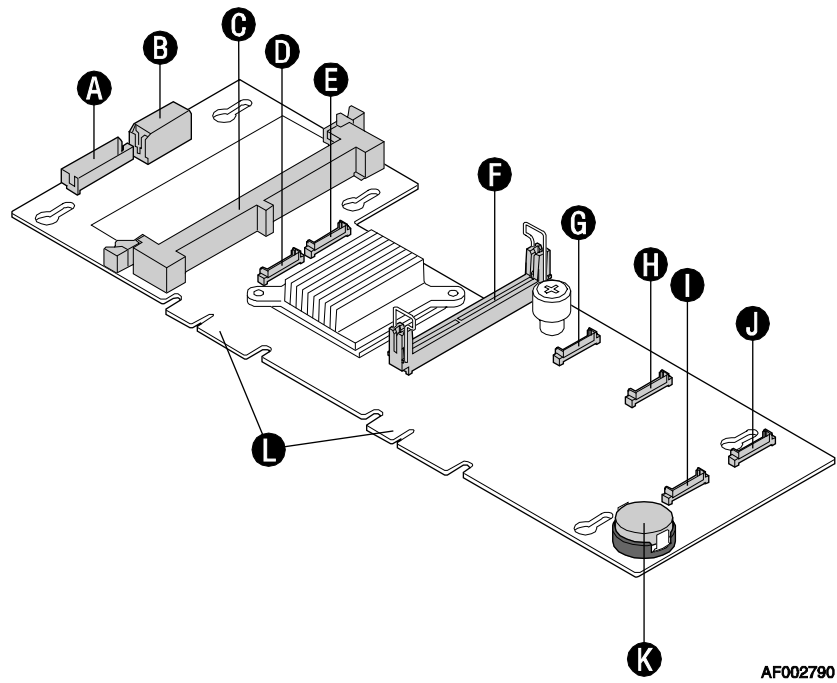

AF002790

A.	RAID Battery Backup Unit Connector	G.	Fan 4 Connector
B.	Power Connector	H.	Fan 3 Connector
C.	Mini-DIMM Connector	I.	Fan 1 Connector
D.	Fan 6 Connector	J.	Fan 2 Connector
E.	Fan 5 Connector	K.	RAID Activation Key Connector
F.	Bridge Board Connector	L.	Backplane Connector

Figure 30. Active Midplane with SAS/SAS RAID Support

7.2.2.1 Active Midplane Architectural Overview

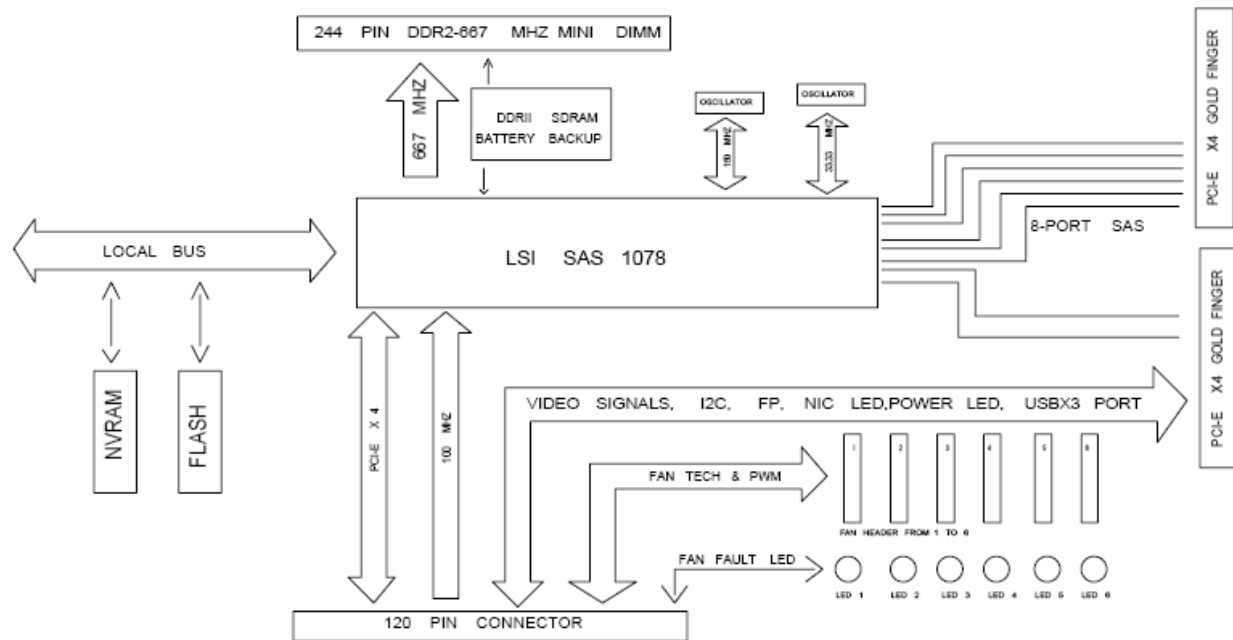

Figure 31. Active Midplane Architecture Diagram

7.2.2.2 x4 PCI Express* Card Edge Interfaces

Two x4 PCI Express* card edges are used to connect the active midplane to the hot-swap backplane. The use of card edge connectors to the backplane eliminates all hard drive cabling.

7.2.2.3 LSI LSISAS1078 SAS Controller

The LSI LSISAS1078 ROC supports transfer rates of up to 3 GB/s on each SAS port. It integrates a high-speed DDR/DDR2 SDRAM interface for Hardware RAID cache. It utilizes a PCI Express* interface to provide transmission and reception rates of up to 10 GB/s over an x4 link.

7.2.2.4 Optional Hardware RAID Support

The active midplane supports options to provide full hardware RAID support. Options required to enable hardware RAID support include an Intel® RAID Activation Key (Product Order Code – AXXRAKSAS2) and installation of a Mini-DIMM (Product Order Code – AXMINIDIMM512) for Intel® RAID Cache support. To protect from data loss during an unexpected power loss event, an Intel® RAID Smart Battery Backup module (AXXRSBBU3) is also supported. Hardware RAID levels supported include 0, 1, 5, 10, 50, 6, and 60.

7.2.2.4.1 Intel® RAID Activation Key

The Intel® RAID Activation Key enables the full intelligent SAS Hardware RAID solution. The activation key plugs directly into a connector (J1A10) on the midplane board. With no RAID activation key installed, only SAS Software RAID levels 0, 1, and 10 are supported.

7.2.2.4.2 Intel RAID Cache support

To further enable support for hardware RAID, the active midplane provides a 244-pin mini-DIMM connector (J8C1), supporting a single registered ECC non-parity DDR2-667 MHz Mini-DIMM to provide Intel RAID cache. Supported mini-DIMM capacities range from 128 MB to 1 GB.

Note: For a list of Intel validated mini-DIMMs, use the Server Configurator Tool available at <http://serverconfigurator.intel.com/default.aspx>.

7.2.2.4.3 Intel® RAID Smart Battery Backup Module

With an Intel® RAID Smart Battery Backup module installed, data loss is prevented when data is still present in the RAID Cache Module and power is unexpectedly lost. Depending on the cache module capacity used, the battery backup unit can provide 48 to 72 hours of battery backup power to allow data stored in the RAID cache to be processed. A 2x10 connector (J9A2) is used to attach the battery backup unit to the midplane.

7.3 Hot-Swap SAS/SATA Backplane

The system supports a multifunctional SAS/SATA backplane supporting the following features:

- Vitesse VSC410 enclosure management controller
 - External non-volatile Flash ROM
 - Four I²C interfaces
 - Compliance with SCSI Accessed Fault Tolerant Enclosures (SAF-TE) specification
 - Compliance with Intelligent Platform Management Interface (IPMI)
- Eight 2.5 inch compatible hot-swap hard drive connectors
- Power for an optional tape drive or two additional 2.5 inch SAS/SATA hard drives
- Hard Drive Status and Fault LEDs for each hard drive connector
- Card edge connectors for most interconnects, including:
 - Midplane
 - Control Panel
 - Slimline SATA Optical Drive
- Temperature Sensor
- FRU EEPROM
- One 2x4-pin Power Connector

7.3.1 SAS/SATA Backplane Layout

The hot-swap backplane installs on the back side of the hot-swap drive bay inside the system. Alignment features on the system and backplane assembly make for easy tool-less installation. For instructions on installing and removing the backplane, see the *Intel® Server System SR1625UR Service Guide*. The following diagram shows the layout of components and connectors found on the board.

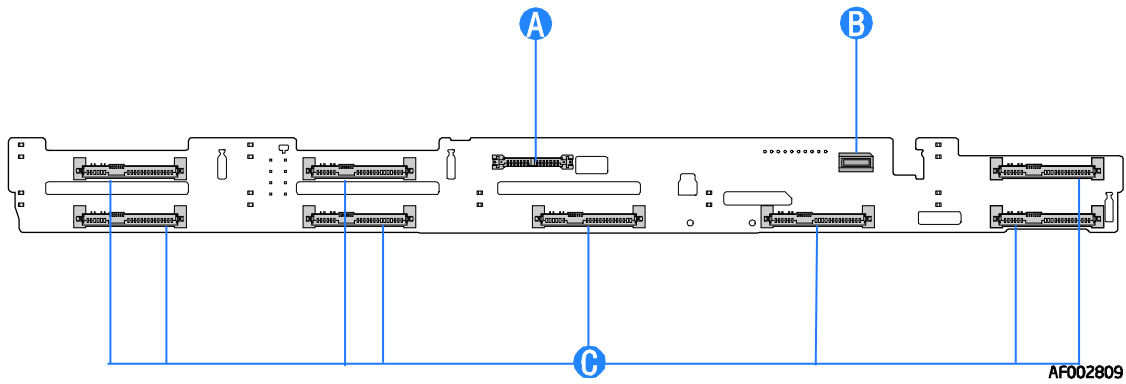

A	Slimline Optical Device Connector	C	SAS/SATA hot-swap Connectors
B	Mini Control Panel Connector		

Figure 32. Hot-Swap SAS/SATA Backplane (Front Side View)

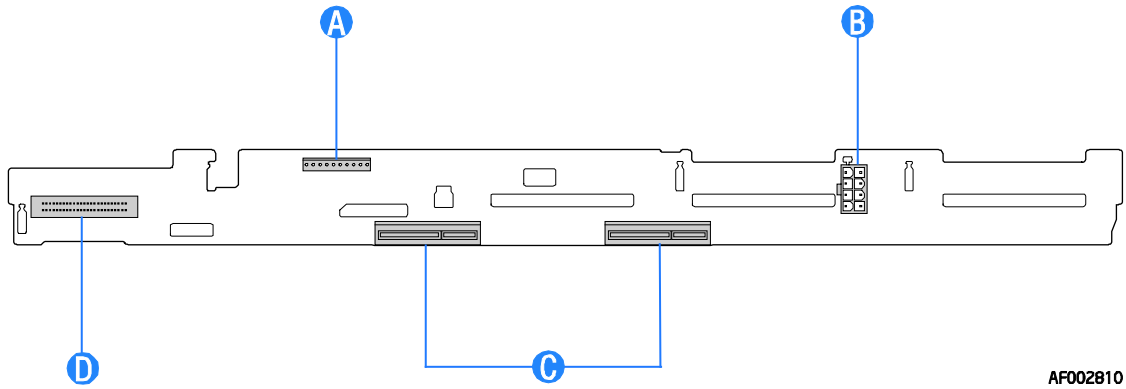

A	USB Connector	C	Card Edge Connectors to Midplane
B	Power Connector	D	10-pin Control Panel Connector

Figure 33. Hot-Swap SAS/SATA Backplane (Back Side View)

Note: Make sure all system boards, peripherals, and cables are detached from the backplane before removing the backplane from the system. Failure to detach components from the backplane before removal may result in component damage.

7.3.2 SAS/SATA Backplane Functional Architecture

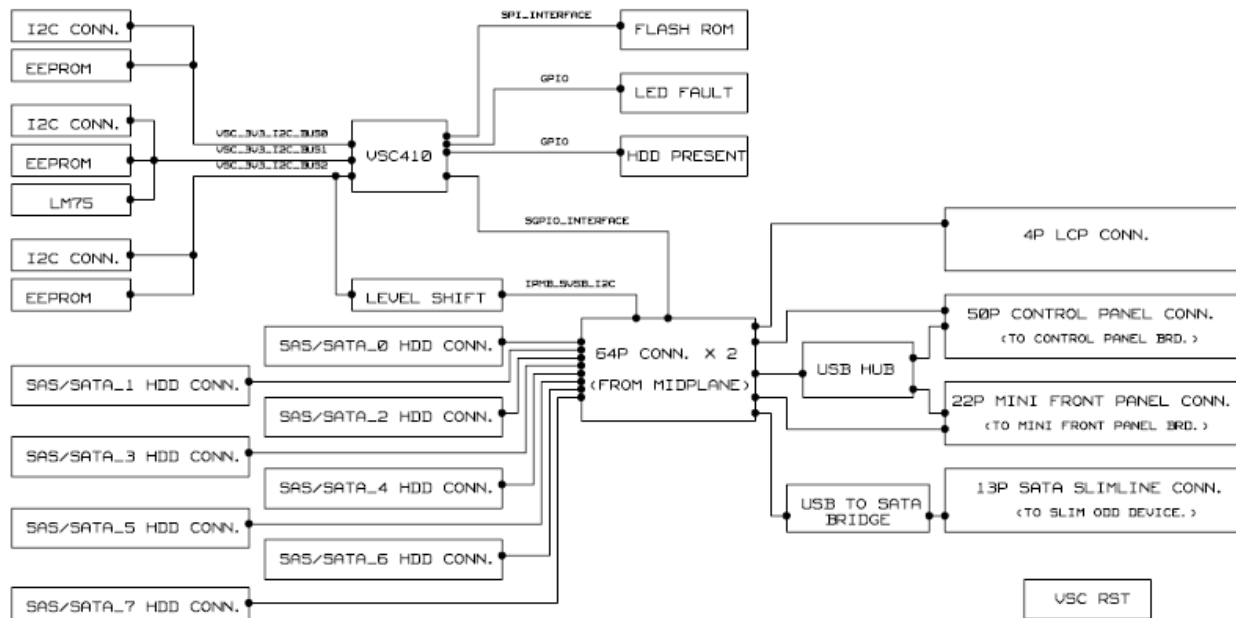

The following figure shows the functional blocks of the SAS/SATA backplane.

Figure 34. SAS/SATA Backplane Functional Block Diagram

7.3.2.1 Enclosure Management Controller

The backplane utilizes the features of the Vitesse VSC410 to implement several enclosure management functions. The chip provides in-band SAF-TE and SES management and utilizes the following four I²C interfaces:

1. I²C bus 0 is connected to an EEPROM, which stores configuration and FRU data.
2. I²C bus 1 is connected to an LM75 temperature sensor.
3. I²C bus 2 is connected to an IPMB bus from the server board.
4. I²C bus 3 is connected to the LSISAS1078 SAS controller.

7.3.2.2 Hard Drive Activity and Fault LEDs

The backplanes support an activity/fault LED for each of the hard drive connectors. The LED will illuminate green for activity or amber for a drive fault. The green activity LED is driven by the SAS/SATA hard disk drive directly. The amber fault LED is driven by the VSC410* management controller whenever a fault condition is detected. When the drive is used in a RAID configuration, the RAID controller has control over the fault LED and it may exhibit different behavior.

Table 40. Hard Drive LED Function Definitions

Status LED	Definition
------------	------------

Green On	HDD Activity
Amber On	HDD Fault

The activity LED functionality is controlled directly by the hard drives. This causes the LED to function differently between SAS and SATA drives. The expected operation is outlined in the following table.

Table 41. Hard Drive Activity LED Functionality

Condition	Drive Type	Behavior
Power on with no drive activity	SAS	Ready LED stays on
	SATA	Ready LED stays off
Power on with drive activity	SAS	Ready LED blinks off when processing a command
	SATA	Ready LED blinks on when processing a command
Power on and drive spun down	SAS	Ready LED stays off
	SATA	Ready LED stays off
Power on and drive spinning up	SAS	Ready LED blinks
	SATA	Ready LED stays off

8. Mini Control Panel Functionality

For system configurations that require eight 2.5 inch hard drives, a mini control panel is used in place of the standard control panel. The mini control panel is modular in design and supports several push buttons and status LEDs, along with one USB port within a very compact design.

The control panel assembly slides into a slot on the front of the system and is blind mated with a slot connector on the backplane.



Figure 35. Mini Control Panel Assembly Module

8.1 Mini Control Panel Buttons

The mini control panel assembly houses three system control buttons. The function of each control button is listed in the following table:

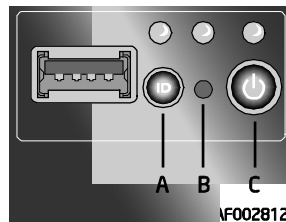

Figure 36. Mini Control Panel Buttons

Table 42. Mini Control Panel Button Functions

Reference	Feature	Function
A	ID Button	Toggles the front panel ID LED and the server board ID LED on/off. The server board ID LED is visible through the rear of the system and allows for server identification and location when working behind a rack of servers.
B	NMI Button	Pressing the recessed button with a paper clip or pin puts the server in a halt state for diagnostic purposes and allows the issuance of a non-maskable interrupt. After issuing the interrupt, a memory download can be performed to determine the cause of the problem.
C	Power/Sleep Button	Toggles the system power on/off. This button also functions as a sleep button if enabled by an ACPI-compliant operating system.

8.2 Mini Control Panel LED Indicators

The control panel houses three LEDs to display the system's operating state. The LEDs are visible with or without the front bezel.

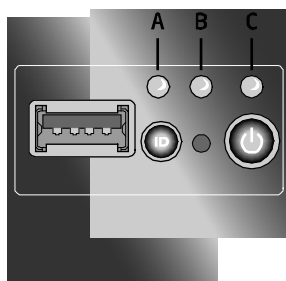
**Figure 37. Mini Control Panel LEDs**

The following table identifies each LED and describes their functionality:

Table 43. Mini Control Panel LED Functions

Reference	LED	Color	State	Description
A	System Identification	Blue	On	Identify active via command or button.
		Off	Off	No Identification.
B	System Status (on standby power)	Green	On	Running/normal operation
			Blink ^{1,2}	Degraded
		Amber	On	Critical or non-recoverable condition.
			Blink ^{1,2}	Non-critical condition.
Off	Off	POST/system stop.		
C	Power/Sleep (on standby power)	Green	On	Legacy power on/ACPI S0 state
			Blink ^{1,3}	Sleep/ACPI S1 state
		Off	Off	Power Off/ACPI S4 or S5 state

Notes:

1. Blink rate is ~1 Hz at 50% duty cycle.
2. The amber status takes precedence over the green status. When the amber LED is on or blinking, the green LED is off.
3. The power LED sleep indication is maintained on standby by the chipset. If the system is powered down without going through the BIOS, the LED state that is in effect at the time of power off is restored when the system is powered on until the BIOS clears it. If the system is not powered down normally, it is

possible that the power LED is blinking while the system status LED is off. This is due to a failure or configuration change that prevents the BIOS from running.

8.2.1 Power/Sleep LED

Table 44. SSI Power LED Operation

State	Power Mode	LED	Description
Power-off	Non-ACPI	Off	System power is off, and the BIOS has not initialized the chipset.
Power-on	Non-ACPI	On	System power is on, but the BIOS has not yet initialized the chipset.
S5	ACPI	Off	Mechanical is off, and the operating system has not saved any context to the hard disk.
S4	ACPI	Off	Mechanical is off. The operating system has saved context to the hard disk.
S3-S1	ACPI	Slow blink ¹	DC power is still on. The operating system has saved context and gone into a level of low-power state.
S0	ACPI	Steady on	System and the operating system are up and running.

Note:

1. Blink rate is ~ 1 Hz at 50% duty cycle.

8.2.2 System Status LED

Table 45. Control Panel LED Operation

Color	State	Criticality	Description
Off	N/A	Not ready	AC power off.
Green	Solid on	Ok	System booted and ready.
Green	Blink	Degraded	System degraded <ul style="list-style-type: none"> ▪ Unable to use all of the installed memory (more than one DIMM installed). ▪ Correctable errors over a threshold of ten and migrating to a spare DIMM (memory sparing). This indicates that the user no longer has spare DIMMs indicating a redundancy lost condition. The corresponding DIMM LED should light up. ▪ In a mirrored configuration, when memory mirroring takes place and system loses memory redundancy. This is not covered by the second bullet above. ▪ Redundancy loss such as power supply or fan. This does not apply to non-redundant subsystems. ▪ PCI Express* link errors. ▪ CPU failure/disabled – if there are two processors and one of them fails. ▪ Fan alarm – Fan failure. Number of operational fans should be more than the minimum number needed to cool the system. ▪ Non-critical threshold crossed – temperature and voltage.
Amber	Blink	Non-critical	Non-fatal alarm – system is likely to fail <ul style="list-style-type: none"> ▪ Critical voltage threshold crossed. ▪ VRD hot asserted. ▪ Minimum number of fans to cool the system are not present or have failed. ▪ In a non-sparing and non-mirroring mode, if the threshold of ten correctable errors is crossed within the window.
Amber	Solid on	Critical, non-recoverable	Fatal alarm – system has failed or shut down <ul style="list-style-type: none"> ▪ DIMM failure when there is one DIMM present and no good

Color	State	Criticality	Description
			memory is present <ul style="list-style-type: none"> ▪ Run-time memory uncorrectable error in non-redundant mode ▪ IERR signal asserted. ▪ Processor 1 missing. ▪ Temperature (e.g. CPU ThermTrip, memory TempHi, critical threshold crossed). ▪ No power good – power fault. ▪ Processor configuration error (e.g. processor stepping mismatch).

8.2.3 System Identification LED

The blue system identification LED is used to help identify a system for servicing. This is especially useful when the system is installed when in a high density rack or cabinet that is populated with several similar systems.

The blue System ID LED can be illuminated using one of the following mechanisms:

- By pressing the System ID Button on the system control panel, the ID LED displays a solid blue color, until the button is pressed again.
- By issuing the appropriate hex IPMI “Chassis Identify” value, the ID LED either blinks blue for 15 seconds and turns off or blinks indefinitely until the appropriate hex IPMI System Identify value is issued to turn it off.

8.3 External Mini Control Panel Connectors

The mini control panel has one external USB port.

Table 46. External USB Connectors

Pin #	Description
1	PWR_FP_USB2
2	USB_DN2_FP_R
3	USB_DP2_FP_R
4	GND
5	GND
6	GND
7	GND

8.4 Internal Mini Control Panel Interconnects

All mini control panel signals are directed through a single 20-pin card edge interconnect. When installed into the system, the mini control panel board blind mates to the hot-swap backplane.

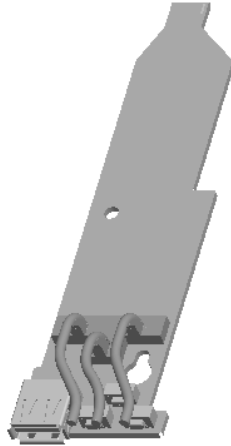

Figure 38. Mini Control Panel PCB

Table 47. 20-pin Mini Control Panel Interconnect

Pin #	Signal Name	Pin #	Signal Name
1	FP_PWR_LED_R_L	2	FP_PWR_BTN_L
3	FP_SYS_FLT_LED1_R_L	4	FAULT_LED_5VSB
5	FP_SYS_FLT_LED2_R_L	6	FP_NMI_BTN_L
7	P5V_STBY_PWRLED_ANODE	8	GND
9	BP_I2C_5V_SCL	10	1_WIRE_BUS
11	BP_I2C_5V_SDA	12	P5V_STBY
13	GND	14	P5V_STBY
15	USB_DP2_FP	16	FP_ID_SW_L
17	USB_DN2_FP	18	FP_ID_LED_R_L
19	GND	20	P5V_FP_USB2_PWR

9. Standard Control Panel Functionality

The standard control panel supports several push buttons and status LEDs, along with USB and video ports to centralize system control, monitoring, and accessibility within a compact design. Using the standard control panel allows up to six 2.5 inch hard drives to be installed in the system.

The standard control panel assembly comes pre-assembled and is modular in design. The control panel assembly module slides into a slot on the front of the system and is cabled to the hot-swap backplane.

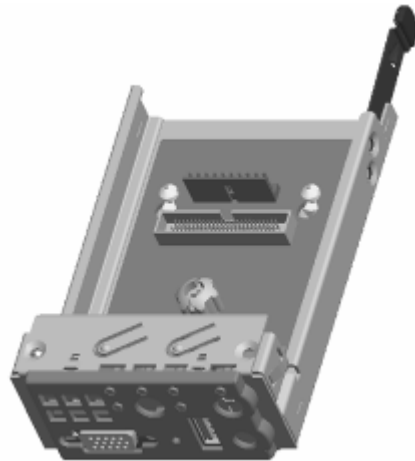
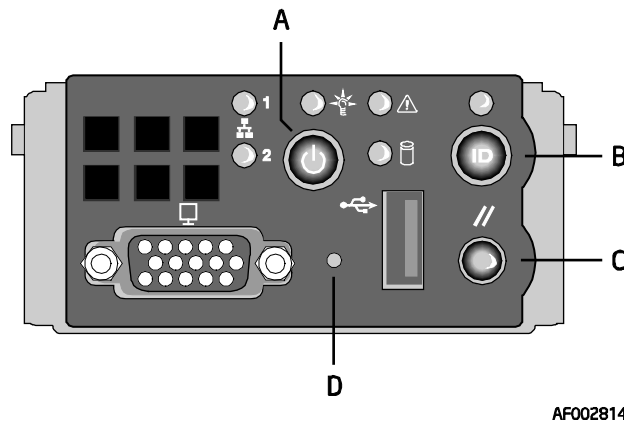

Figure 39. Standard Control Panel Assembly Module

9.1 Standard Control Panel Buttons

The standard control panel assembly houses several system control buttons. The function of each control button is listed in the following table.



AF002814

Figure 40. Standard Control Panel Buttons

Table 48. Standard Control Button and Intrusion Switch Functions

Reference	Feature	Function
A	Power/Sleep Button	Toggles the system power on/off. This button also functions as a Sleep button if enabled by an ACPI-compliant operating system.
B	ID Button	Toggles the front panel ID LED and the server board ID LED on/off. The server board ID LED is visible through the rear of the system and allows for easy identification and location when working from behind a rack of servers.
C	Reset Button	Reboots and initializes the system.
D	NMI Button	Pressing the recessed button with a paper clip or pin puts the server in a halt state for diagnostic purposes and allows the issuance of a non-maskable interrupt. After issuing the interrupt, a memory download can be performed to determine the cause of the problem.

9.2 Standard Control Panel LED Indicators

The control panel houses six LEDs to display the system's operating state. The LEDs are visible with or without the front bezel.

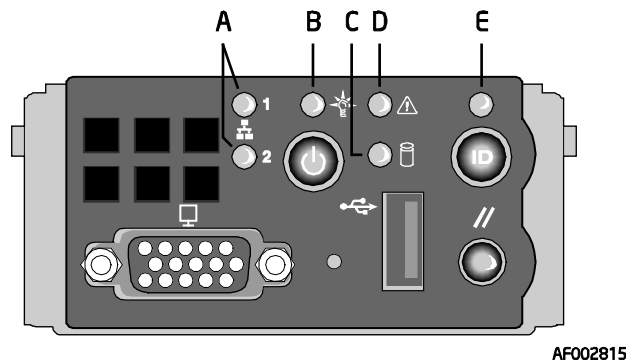
**Figure 41. Standard Control Panel LEDs**

The following table identifies each LED and describes their functionality:

Table 49. Standard Control Panel LED Functions

Reference	LED	Color	State	Description
A	NIC1/NIC2 Activity	Green	On	NIC Link.
		Green	Blink	NIC Activity.
B	Power/Sleep (on standby power)	Green	On	Legacy power on/ACPI S0 state.
			Blink ^{1,4}	Sleep/ACPI S1 state.
		Off	Off	Power Off/ACPI S4 or S5 state.
C	Disk Activity	Green	Random blink	Provides an indicator for disk activity.
		Off	Off ³	No hard disk activity.
D	System Status (on standby power)	Green	On	Running/normal operation.
			Blink ^{1,2}	Degraded
		Amber	On	Critical or non-recoverable condition.
			Blink ^{1,2}	Non-critical condition.
Off	Off	POST/system stop.		
E	System Identification	Blue	On	Identify active via command or button.
		Off	Off	No Identification.

Notes:

1. Blink rate is ~1 Hz at 50% duty cycle.
2. The amber status takes precedence over the green status. When the amber LED is on or blinking, the green LED is off.
3. Off when the system is powered off (S4/S5) or in a sleep state (S1).
4. The power LED sleep indication is maintained on standby by the chipset. If the system is powered down without going through the BIOS, the LED state that is in effect at the time of power off is restored when the system is powered on until the BIOS clears it. If the system is not powered down normally, it is possible that the power LED is blinking while the system status LED is off. This is due to a failure or configuration change that prevents the BIOS from running.

The current limiting resistors for the power LED, the system fault LED, and the NIC LEDs are located on the server board.

9.2.1 Power/Sleep LED

Table 50. SSI Power LED Operation

State	Power Mode	LED	Description
Power-off	Non-ACPI	Off	System power is off, and the BIOS has not initialized the chipset.
Power-on	Non-ACPI	On	System power is on, but the BIOS has not yet initialized the chipset.
S5	ACPI	Off	Mechanical is off, and the operating system has not saved any context to the hard disk.
S4	ACPI	Off	Mechanical is off. The operating system has saved context to the hard disk.
S3-S1	ACPI	Slow blink ¹	DC power is still on. The operating system has saved context and gone into a level of low-power state.
S0	ACPI	Steady on	System and the operating system are up and running.

Note:

1. Blink rate is ~ 1 Hz at 50% duty cycle.

9.2.2 System Status LED

Table 51. Control Panel LED Operation

Color	State	Criticality	Description
Off	N/A	Not ready	AC power off.
Green	Solid on	Ok	System booted and ready.
Green	Blink	Degraded	<p>System degraded</p> <ul style="list-style-type: none"> ▪ Unable to use all of the installed memory (more than one DIMM installed). ▪ Correctable errors over a threshold of ten and migrating to a spare DIMM (memory sparing). This indicates that the user no longer has spare DIMMs indicating a redundancy lost condition. The corresponding DIMM LED should light up. ▪ In a mirrored configuration, when memory mirroring takes place and system loses memory redundancy. This is not covered by the second bullet above. ▪ Redundancy loss such as power supply or fan. This does not apply to non-redundant subsystems. ▪ PCI Express* link errors. ▪ CPU failure/disabled – if there are two processors and one of them fails. ▪ Fan alarm – Fan failure. Number of operational fans should be more than the minimum number needed to cool the system. ▪ Non-critical threshold crossed – Temperature and voltage.
Amber	Blink	Non-critical	<p>Non-fatal alarm – system is likely to fail</p> <ul style="list-style-type: none"> ▪ Critical voltage threshold crossed. ▪ VRD hot asserted. ▪ Minimum number of fans to cool the system are not present or have failed. <p>In a non-sparing and non-mirroring mode, if the threshold of ten correctable errors is crossed within the window.</p>
Amber	Solid on	Critical, non-recoverable	<p>Fatal alarm – system has failed or shut down</p> <ul style="list-style-type: none"> ▪ DIMM failure when there is one DIMM present and no good memory is present ▪ Run-time memory uncorrectable error in non-redundant mode ▪ IERR signal asserted ▪ Processor 1 missing ▪ Temperature (e.g. CPU ThermTrip, memory TempHi, critical threshold crossed) ▪ No power good – power fault <p>Processor configuration error (e.g. processor stepping mismatch)</p>

9.2.3 Drive Activity LED

The drive activity LED on the front panel indicates drive activity from the on-board hard disk controllers. The Intel® Server Board S5520UR also provides a header giving access to this LED for add-in controllers.

9.2.4 System Identification LED

The blue system identification LED is used to help identify a system for servicing. This is especially useful when the system is installed in a high density rack or cabinet that is populated with several similar systems. The system ID LED blinks when the System ID button on the control panel is pressed or it can be illuminated remotely through the server management software.

9.3 External Standard Control Panel Connectors

The standard control panel has two external I/O connectors:

- One USB port
- One VGA video port

The following tables provide the pin-outs for each connector.

Table 52. External USB Connectors

Pin #	Description
1	PWR_FP_USB2
2	USB_DN2_FP_R
3	USB_DP2_FP_R
4	GND
5	GND
6	GND
7	GND

Table 53. Video Connector

Description	Pin #	Pin #	Description
VGA_RED	1	9	GND
VGA_GREEN	2	10	GND
VGA_BLUE	3	11	Unused
Unused	4	12	VGA_DDCDAT
GND	5	13	VGA_HSYNC_L
GND	6	14	VGA_VSYNC_L
VGA_INUSE_L	7	15	VGA_DDCCLK
GND	8	16	GND
		17	GND

If a monitor is connected to the control panel video connector, the rear video port on the server board is disabled and the control panel video is enabled. The video source is the same for both connectors and is switched between the two, with the rear video having priority over the control panel. This provides easy front accessibility to the server.

9.4 Internal Standard Control Panel Interconnect

All standard control panel signals are directed through a single 50-pin signal connector and 10-pin USB connector. The standard control panel board is cabled to the hot-swap backplane.

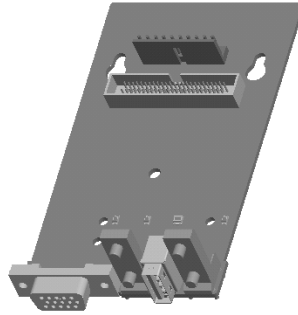

Figure 42. Standard Control Panel PCB

Table 54. 50-pin Standard Control Panel Signal Connector

Pin #	Signal Name	Pin #	Signal Name
1	V_IO_RED_CONN_FP	2	GND
3	V_IO_GREEN_CONN_FP	4	GND
5	V_IO_BLUE_CONN_FP	6	GND
7	V_IO_HSYNC_BUFF_FP_L	8	GND
9	V_IO_VSYNC_BUFF_FP_L	10	GND
11	V_VIDEO_IN_USE	12	FP_THERM_SENSOR
13	SP_DTR2_L	14	SP_DCD2_L
15	SP_RTS2_L	16	SP_CTS2_L
17	SP_SIN2	18	SP_SOUT2
19	SP_DSR2_L	20	SP_IN_USE
21	FP_NMI_BTN_L	22	GND
23	LED_NIC1_ACT_L	24	LED_NIC1_LINK_R_L
25	Not Used	26	FP_CHASSIS_INTRU
27	FP_ID_SW_L	28	SMB_PB1_5VSB_CLK
29	GND	30	SMB_PB1_5VSB_DAT
31	RST_FP_BTN_L	32	LED_NIC2_ACT_L
33	LED_HDD_FLT_R_L	34	LED_NIC2_LINK_R_L
35	FP_PWR_BTN_L	36	LED_FP_ID_R_L
37	SMB_IPMB_5VSB_CLK	38	GND
39	SMB_IPMB_5VSB_DAT	40	PV_HDD_LED_3V_A
41	LED_FP_PWR_R_L	42	FP_FLT_LED_5VSB
43	FP_PWR_LED_5VSB	44	LED_FP_SYS_FLT2_R_L
45	RST_PWRGD_PS	46	LED_FP_SYS_FLT1_R_L
47	LED_HDD_ACT_RR_L	48	P5V
49	P5V_STBY	50	P5V_STBY

Table 55. 10-pin Standard Control Panel USB Connector

Pin #	Signal Description
1	P5V_USB_P1
2	USB_P1N
3	USB_P1P
4	GND
5	GND
6	P5V_USB_P2
7	USB_P2N
8	USB_P2P
9	GND
10	GND

10. Intel® Local Control Panel Functionality

The Intel® Local Control Panel (LCP) utilizes a combination of control buttons, LEDs, and LCD display to provide system accessibility, monitoring, and control functions. The pre-assembled module slides into a slot on the front of the chassis where it is cabled to the backplane. The LCP module is designed so that it can be adjusted for use with or without an outer front bezel. Using the Intel® Local Control Panel allows up to six 2.5 inch hard drives to be installed in the system.

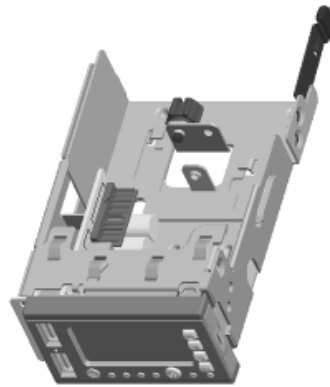
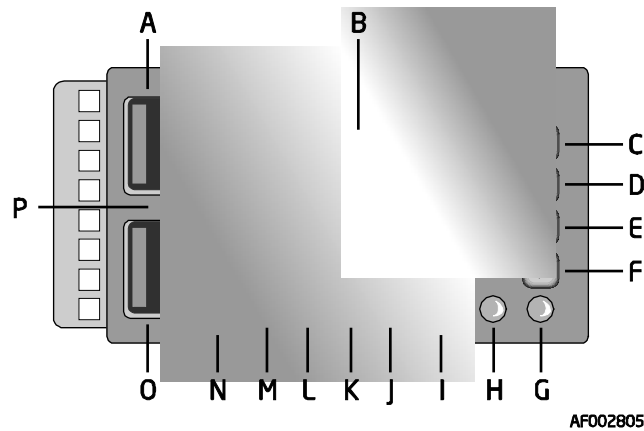

Figure 43. Intel® Local Control Panel Assembly Module

The following diagram provides an overview of the control panel features:



A	USB 1.1 Port	I	System Power Button
B	LCD Display	J	System Status LED
C	LCD Menu Control Button – Up	K	NIC 2 Activity LED
D	LCD Menu Control Button – Down	L	NIC 1 Activity LED
E	LCD Menu Control Button – Previous Option	M	Hard Drive Activity LED
F	LCD Menu Control Button – Previous Page	N	System Reset Button
G	ID LED	O	USB 1.1 Port
H	Power LED	P	NMI Button (Tool Required)

Figure 44. Intel® Local Control Panel Overview

10.1 LED Functionality

The following table identifies each LED and describes their functionality:

Table 56. LCP Control Panel LED Functions

LED	Color	State	Description
NIC1/NIC2 Activity	Green	On	NIC Link.
	Green	Blink	NIC Activity.
Power/Sleep (on standby power)	Green	On	Legacy power on/ACPI S0 state.
		Blink ^{1,4}	Sleep/ACPI S1 state.
	Off	Off	Power Off/ACPI S4 or S5 state.
System Status (on standby power)	Green	On	Running/normal operation.
		Blink ^{1,2}	Degraded
	Amber	On	Critical or non-recoverable condition.
		Blink ^{1,2}	Non-critical condition.
Off	Off	POST/system stop.	
Disk Activity	Green	Random blink	Provides an indicator for disk activity.
	Off	Off ³	No hard disk activity.
System Identification	Blue	On	Identify active via command or button.
	Off	Off	No Identification.

Notes:

1. Blink rate is ~1 Hz at 50% duty cycle.
2. The amber status takes precedence over the green status. When the amber LED is on or blinking, the green LED is off.
3. Off when the system is powered off (S4/S5) or in a sleep state (S1).
4. The power LED sleep indication is maintained on standby by the chipset. If the system is powered down without going through the BIOS, the LED state that is in effect at the time of power off is restored when the system is powered on until the BIOS clears it. If the system is not powered down normally, it is possible that the Power LED is blinking while the system status LED is off. This is due to a failure or configuration change that prevents the BIOS from running.

The current limiting resistors for the power LED, the system fault LED, and the NIC LEDs are located on the Intel® Server Board S5520UR.

10.1.1 Power/Sleep LED

Table 57. SSI Power LED Operation

State	Power Mode	LED	Description
Power Off	Non-ACPI	Off	System power is off, and the BIOS has not initialized the chipset.
Power On	Non-ACPI	On	System power is on, but the BIOS has not yet initialized the chipset.
S5	ACPI	Off	Mechanical is off, and the operating system has not saved any context to the hard disk.
S4	ACPI	Off	Mechanical is off. The operating system has saved context to the hard disk.
S3-S1	ACPI	Slow blink ¹	DC power is still on. The operating system has saved context and gone into a level of low-power state.
S0	ACPI	Steady on	System and the operating system are up and running.

Note:

1. Blink rate is ~ 1 Hz with at 50% duty cycle.

10.1.2 System Status LED

Table 58. Control Panel LED Operation

Color	State	Criticality	Description
Off	N/A	Not ready	AC power off
Green	Solid on	Ok	System booted and ready
Green	Blink	Degraded	<p>System degraded</p> <ul style="list-style-type: none"> ▪ Unable to use all of the installed memory (more than one DIMM installed). ▪ Correctable errors over a threshold of ten and migrating to a spare DIMM (memory sparing). This indicates that the user no longer has spare DIMMs indicating a redundancy lost condition. The corresponding DIMM LED should light up. ▪ In a mirrored configuration, when memory mirroring takes place and system loses memory redundancy. This is not covered by the second bullet above. ▪ Redundancy loss such as power supply or fan. This does not apply to non-redundant subsystems. ▪ PCI Express* link errors. ▪ CPU failure/disabled – if there are two processors and one of them fails. ▪ Fan alarm – Fan failure. Number of operational fans should be more than the minimum number needed to cool the system. ▪ Non-critical threshold crossed – temperature and voltage.
Amber	Blink	Non-critical	<p>Non-fatal alarm – system is likely to fail</p> <ul style="list-style-type: none"> ▪ Critical voltage threshold crossed. ▪ VRD hot asserted. ▪ Minimum number of fans to cool the system are not present or have failed. ▪ In a non-sparing and non-mirroring mode, if the threshold of ten correctable errors is crossed within the window.
Amber	Solid on	Critical, non-recoverable	<p>Fatal alarm – system has failed or shut down</p> <ul style="list-style-type: none"> ▪ DIMM failure when there is one DIMM present, no good memory present. ▪ Run-time memory uncorrectable error in non-redundant mode. ▪ IERR signal asserted. ▪ Processor 1 missing. ▪ Temperature (e.g. CPU ThermTrip, memory TempHi, critical threshold crossed). ▪ No power good – power fault. ▪ Processor configuration error (e.g. processor stepping mismatch).

10.1.3 System Identification LED

The blue system identification LED is used to help identify a system for servicing. This is especially useful when the system is installed in a high density rack or cabinet that is populated with several similar systems.

The blue System ID LED can be illuminated using one of the following mechanisms:

- By pressing the System ID button on the system control panel, the ID LED displays a solid blue color until the button is pressed again.
- By issuing the appropriate hex IPMI “Chassis Identify” value, the ID LED either blinks blue for 15 seconds and turns off or blinks indefinitely until the appropriate hex IPMI Chassis Identify value is issued to turn it off.

10.2 Intel® Local Control Panel Interconnects

The Intel® Local Control Panel module includes the Intel® Local Control Panel interface board and a USB interface board. Connectors on the Intel® Local Control Panel interface board and USB interface board are cabled to matching connectors on the hot-swap backplane. This section defines the pin-out for each connector and header found on both the Intel® Local Control Panel interface board and interposer board.

- Signals from the card edge connector are routed to the Intel® Local Control Panel interface board through matching 50-pin connectors on the interposer board and the Intel® Local Control Panel interface board. The 50-pin connectors are attached using a small 50-pin flat cable.
- USB signals from the card edge connector are routed to the Intel® Local Control Panel interface board through matching 10-pin connectors on the interposer board and the Intel® Local Control Panel interface board. The 10-pin connectors are attached using a small 10-pin round cable.
- A 4-pin NMI/Temp Sensor Header (cables between the Intel® Local Control Panel interface board and the USB interface board).

The following tables provide the pin-outs for each connector:

Table 59. 50-pin Intel® Local Control Panel Signal Connector

Pin #	Signal Name	Pin #	Signal Name
1	V_IO_RED_CONN_FP	2	GND
3	V_IO_GREEN_CONN_FP	4	GND
5	V_IO_BLUE_CONN_FP	6	GND
7	V_IO_HSYNC_BUFF_FP_L	8	GND
9	V_IO_VSYNC_BUFF_FP_L	10	GND
11	V_VIDEO_IN_USE	12	FP_THERM_SENSOR
13	SP_DTR2_L	14	SP_DCD2_L
15	SP_RTS2_L	16	SP_CTS2_L
17	SP_SIN2	18	SP_SOUT2
19	SP_DSR2_L	20	SP_IN_USE
21	FP_NMI_BTN_L	22	GND
23	LED_NIC1_ACT_L	24	LED_NIC1_LINK_R_L
25	Not Used	26	FP_CHASSIS_INTRU
27	FP_ID_SW_L	28	SMB_PB1_5VSB_CLK
29	GND	30	SMB_PB1_5VSB_DAT
31	RST_FP_BTN_L	32	LED_NIC2_ACT_L
33	LED_HDD_FLT_R_L	34	LED_NIC2_LINK_R_L
35	FP_PWR_BTN_L	36	LED_FP_ID_R_L
37	SMB_IPMB_5VSB_CLK	38	GND
39	SMB_IPMB_5VSB_DAT	40	PV_HDD_LED_3V_A
41	LED_FP_PWR_R_L	42	FP_FLT_LED_5VSB
43	FP_PWR_LED_5VSB	44	LED_FP_SYS_FLT2_R_L
45	RST_PWRGD_PS	46	LED_FP_SYS_FLT1_R_L
47	LED_HDD_ACT_RR_L	48	P5V
49	P5V_STBY	50	P5V_STBY

Table 60. 10-pin Control Panel USB Connector

Pin #	Signal Description
1	P5V_USB_P1
2	USB_P1N
3	USB_P1P
4	GND
5	GND
6	P5V_USB_P2
7	USB_P2N
8	USB_P2P
9	GND
10	GND

Table 61. Internal NMI/Temp Sensor Header

Pin #	Description
1	DGND
2	FP_NMI_BTN_L
3	+3_3VSB
4	1_WIRE_BUS

11. PCI Riser Cards and Assembly

The Intel® Server System SR1625UR provides one x16 PCI Express* Gen 2 PCI riser slot capable of supporting a full-length full-height PCI Express* add-in card.

When re-inserting the riser assembly into the system, tabs on the back of the assembly should be aligned with slots on the back edge of the system. The tabs fit into the slots securing the riser assembly to the system when the top cover is in place. For additional information, see the *Intel® Server System SR1625UR Service Guide*.

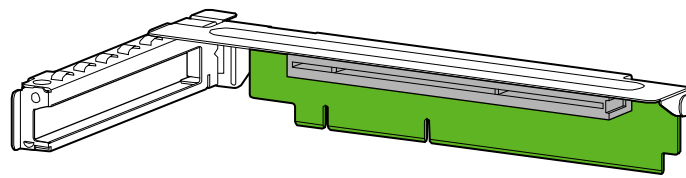

AF002207

Figure 45. PCI Riser Card Assembly

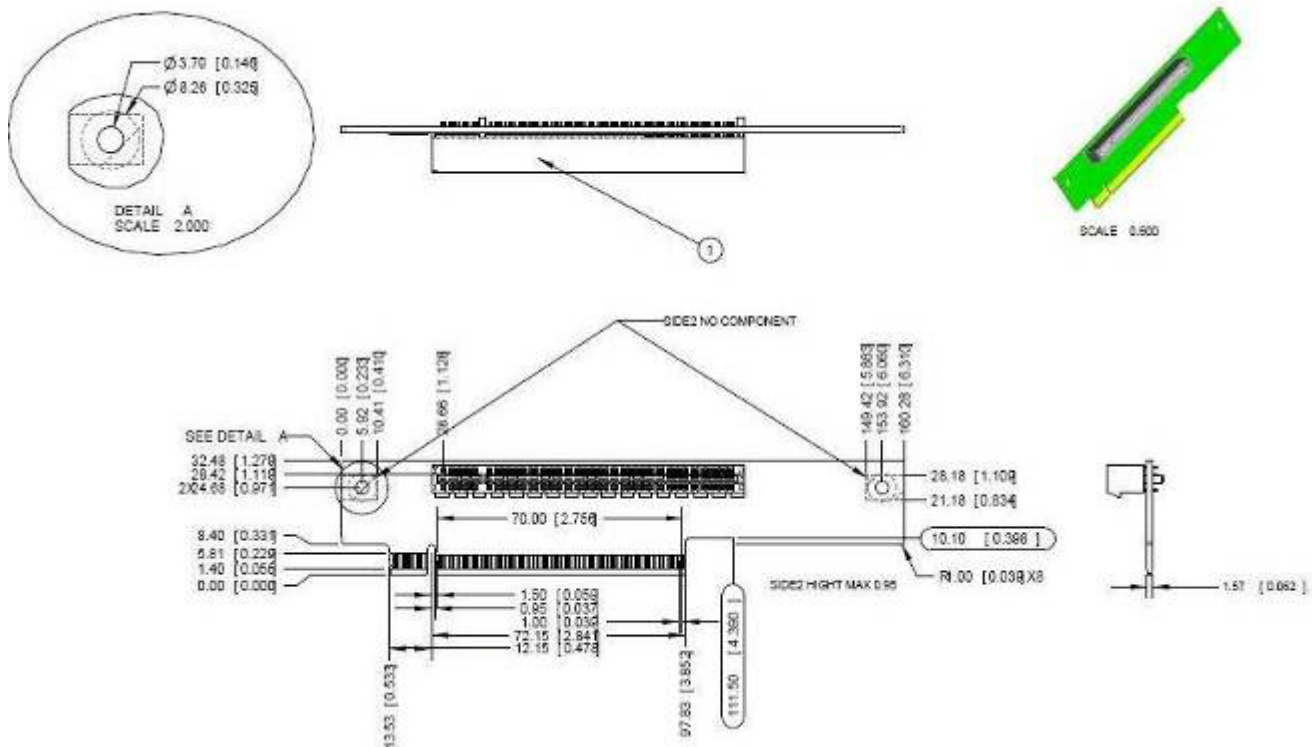

Figure 46. 1U Full-height PCI Express* Riser Card Mechanical Drawing

12. Environmental Specifications

12.1 System Level Environmental Limits

The following table defines the system level operating and non-operating environmental limits.

Table 62. System Environmental Limits Summary

Parameter	Limits
Operating Temperature	+10°C to +35°C with the maximum rate of change not to exceed 10°C per hour
Non-Operating Temperature	-40°C to +70°C
Non-Operating Humidity	90%, non-condensing at 35°C
Acoustic noise	Sound power: 7.0 BA in an idle state at typical office ambient temperature. (23 +/- 2 degrees C)
Shock, operating	Half sine, 2 g peak, 11 milliseconds
Shock, unpackaged	Trapezoidal, 25 g, velocity change 136 inches/second (≥ 40 lbs to < 80 lbs)
Shock, packaged	Non-palletized free fall in height 24 inches (≥ 40 lbs to < 80 lbs)
Vibration, unpackaged	5 Hz to 500 Hz, 2.20 g RMS random
Shock, operating	Half sine, 2 g peak, 11 milliseconds
ESD	+/-15 KV except I/O port +/- 8 KV per Intel® Environmental test specification
System Cooling Requirement in BTU/Hr	2550 BTU/hour
Operating Temperature	+10°C to +35°C with the maximum rate of change not to exceed 10°C per hour

12.2 Serviceability and Availability

The system is designed to be serviced by qualified technical personnel only.

The desired Mean Time To Repair (MTTR) of the system is 30 minutes, including diagnosis of the system problem. To meet this goal, the system enclosure and hardware have been designed to minimize the MTTR.

The following table defines the maximum time needed by a trained field service technician to perform the listed system maintenance procedures, after diagnosing the system and identifying the failed component.

Table 63. Time Estimate for System Maintenance Procedures

Activity	Time Estimate
Remove cover	1 min
Remove and replace hard disk drive	1 min
Remove and replace power supply module	1 min
Remove and replace system fan	3 min
Remove and replace backplane board	10 min
Remove and replace control panel module	2 min
Remove and replace server board	15 min

12.3 Replacing the Backup Battery

The lithium battery on the server board powers the real time clock (RTC) for up to 10 years in the absence of power. When the battery starts to weaken, it loses voltage, and the server settings stored in CMOS RAM in the RTC (e.g., the date and time) may be wrong. Contact your customer service representative or dealer for a list of approved devices.



WARNING

Danger of explosion if battery is incorrectly replaced. Replace only with the same or equivalent type recommended by the equipment manufacturer. Discard used batteries according to manufacturer's instructions.



ADVARSEL!

Lithiumbatteri - Eksplosjonsfare ved fejløgt håndtering. Udskiftning må kun ske med batteri af samme fabrikat og type. Levér det brugte batteri tilbage til leverandøren.



ADVARSEL

Lithiumbatteri - Eksplosjonsfare. Ved utskifting benyttes kun batteri som anbefalt av apparatfabrikanten. Brukt batteri returneres apparatleverandøren.



VARNING

Explosionsfara vid felaktigt batteribyte. Använd samma batterityp eller en ekvivalent typ som rekommenderas av apparattillverkaren. Kassera använt batteri enligt fabrikantens instruktion.



VAROITUS

Paristo voi räjähtää, jos se on virheellisesti asennettu. Vaihda paristo ainoastaan laitevalmistajan suosittelemaan tyyppiin. Hävitä käytetty paristo valmistajan ohjeiden mukaisesti.

13. Regulatory and Certification Information



WARNING

To ensure regulatory compliance, you must adhere to the assembly instructions in this document to ensure and maintain compliance with existing product certifications and approvals. Use only the described, regulated components specified in this document. Use of other products/components will void the UL listing and other regulatory approvals of the product and will most likely result in noncompliance with product regulations in the region(s) in which the product is sold.

To help ensure EMC compliance with your local regional rules and regulations, before computer integration, make sure that the chassis, power supply, and other modules have passed EMC testing using a server board with a microprocessor from the same family (or higher) and operating at the same (or higher) speed as the microprocessor used on this server board. The final configuration of your end system product may require additional EMC compliance testing. For more information please contact your local Intel Representative.

This is an FCC Class A device. Integration of it into a Class B chassis does not result in a Class B device.

13.1 Product Regulatory Compliance

The server chassis product, when correctly integrated per this document, complies with the following safety and electromagnetic compatibility (EMC) regulations.

Intended Application – This product was evaluated as Information Technology Equipment (ITE), which may be installed in offices, schools, computer rooms, and similar commercial type locations. The suitability of this product for other product categories and environments (such as medical, industrial, telecommunications, NEBS, residential, alarm systems, test equipment, etc.), other than an ITE application, may require further evaluation.

13.1.1 Product Safety Compliance

- UL60950 – CSA 60950(USA/Canada)
- EN60950 (Europe)
- IEC60950 (International)
- CB Certificate & Report, IEC60950 (report to include all country national deviations)
- GS Certification (Germany)
- GOST R 50377-92 - Certification (Russia)
- Belarus Certification (Belarus)
- Ukraine Certification (Ukraine)
- CE - Low Voltage Directive 73/23/EEE (Europe)
- IRAM Certification (Argentina)

13.1.2 Product EMC Compliance – Class A Compliance

- FCC /ICES-003 - Emissions (USA/Canada) Verification
- CISPR 22 – Emissions (International)
- EN55022 - Emissions (Europe)
- EN55024 - Immunity (Europe)
- EN61000-3-2 - Harmonics (Europe)
- EN61000-3-3 - Voltage Flicker (Europe)
- CE – EMC Directive 89/336/EEC (Europe)
- VCCI Emissions (Japan)
- AS/NZS 3548 Emissions (Australia/New Zealand)
- BSMI CNS13438 Emissions (Taiwan)
- GOST R 29216-91 Emissions (Russia)
- GOST R 50628-95 Immunity (Russia)
- Belarus Certification (Belarus)
- Ukraine Certification (Ukraine)
- KCC Certification (EMI) (Korea)

13.1.3 Product Ecology Compliance

Intel has a system in place to restrict the use of banned substances in accordance with world wide regulatory requirements. A Material Declaration Data Sheet is available for Intel products. For more reference on material restrictions and compliance you can view Intel's Environmental Product Content Specification at <http://supplier.intel.com/ehs/environmental.htm>.

- Europe - European Directive 2002/95/EC - Restriction of Hazardous Substances (RoHS) Threshold limits and banned substances are noted below.
Quantity limit of 0.1% by mass (1000 PPM) for:
Lead, Mercury, Hexavalent Chromium, Polybrominated Biphenyls Diphenyl Ethers (PBB/PBDE)
Quantity limit of 0.01% by mass (100 PPM) for:
Cadmium
- California Code of Regulations, Title 22, Division 4.5, Chapter 33: Best Management Practices for Perchlorate Materials
- China – Restriction of Hazardous Substances (China RoHS)
- WEEE Directive (Europe)
- Packaging Directive (Europe)

13.1.4 Certifications/Registrations/Declarations









- NRTL Certification (US/Canada)
- CE Declaration of Conformity (CENELEC Europe)
- FCC/ICES-003 Class A Attestation (USA/Canada)
- VCCI Certification (Japan)
- C-Tick Declaration of Conformity (Australia)
- MED Declaration of Conformity (New Zealand)

- BSMI Certification (Taiwan)
- GOST R Certification/Certification (Russia)
- Belarus Certification/Certification (Belarus)
- KCC Certification (Korea)
- IRAM Certification (Argentina)
- Ecology Declaration (International)
- China RoHS Environmental Friendly Use Period
- Packaging & Product Recycling Marks

13.2 Product Regulatory Compliance Markings

This Intel Server Chassis product is provided with the following regulatory and safety markings. In the event there is no room for a marking(s) on the chassis, the information is provided here in this document.

Regulatory Compliance	Country	Marking
cULus Listing Marks	USA/Canada	
GS Mark	Germany	
CE Mark	Europe	
FCC Marking (Class A)	USA	This device complies with Part 15 of the FCC Rules. Operation of this device is subject to the following two conditions: (1) This device may not cause harmful interference, and (2) This device must accept any interference received, including interference that may cause undesired operation. Manufactured by Intel Corporation
EMC Marking (Class A)	Canada	CANADA ICES-003 CLASS A CANADA NMB-003 CLASSE A
VCCI Marking (Class A)	Japan	この装置は、クラス A 情報技術装置です。この装置を家庭環境で使用すると電波妨害を引き起こすことがあります。この場合には使用者が適切な対策を講ずるよう要求されることがあります。VCCI-A
BSMI Certification Number & Class A Warning	Taiwan	

Regulatory Compliance	Country	Marking	
		<p>警告使用者： 這是甲類的資訊產品，在居住的環境中使用時，可能會造成射頻干擾，在這種情況下，使用者會被要求採取某些適當的對策</p>	
GOST R Marking	Russia		
KCC Mark (Korean Communications Commission)	Korea		
Belarus Safety Compliance Mark	Belarus		
Waste of Electronic and Electrical Equipment Recycling Mark	Europe		
China Restriction of Hazardous Substance Environmental Friendly Use Period Mark	China		
China Recycling Mark	China		
Recycling Marks	International		 <p>Corrugated Recycles</p>
Battery Perchlorate Warning Information	California	<p>Perchlorate Material – Special handling may apply. See www.dtsc.ca.gov/hazardouswaste/perchlorate This notice is required by California Code of Regulations, Title 22, Division 4.5, and Chapter 33: Best Management Practices for Perchlorate Materials. This product may include a battery which contains Perchlorate material.</p>	
Safety	Multiple Power Cord Marking	 <p>This unit has more than one power supply cord. To reduce the risk of electrical shock, disconnect (2) two power supply cords before servicing. Simplified Chinese: 注意：</p>	

Regulatory Compliance	Country	Marking
		<p>本设备包括多条电源系统电缆。为避免遭受电击，在进行维修之前应断开两（2）条电源系统电缆。</p> <p>Traditional Chinese: 注意： 本設備包括多條電源系統電纜。為避免遭受電擊，在進行維修之前應斷開兩（2）條電源系統電纜。</p> <p>German: Dieses Geräte hat mehr als ein Stromkabel. Um eine Gefahr des elektrischen Schlages zu verringern trennen sie beide (2) Stromkabeln bevor Instandhaltung.</p>
Nordic Countries	Connection to Proper Ground Outlet	<p>“WARNING:” “Apparaten skall anslutas till jordat uttag, när den ansluts till ett nätverk.” “Laite on liitettävä suojamaadoituskoskettimilla varustettuun pistorasiaan.” “Connect only to a properly earth grounded outlet.”</p>
Safety	Stand-by power	

13.3 Rack Mount Installation Guidelines

Anchor the equipment rack: The equipment rack must be anchored to an unmovable support to prevent it from falling over when one or more servers are extended in front of the rack on slides. You must also consider the weight of any other device installed in the rack. A crush hazard exists should the rack tilt forward which could cause serious injury.

Temperature: The temperature, in which the server operates when installed in an equipment rack, must not go below 5 °C (41 °F) or rise above 40 °C (104 °F). Extreme fluctuations in temperature can cause a variety of problems in your server.

Ventilation: The equipment rack must provide sufficient airflow to the front of the server to maintain proper cooling. The rack must also include ventilation sufficient to exhaust a maximum of 1023 BTU's (British Thermal Units) per hour for the server. The rack selected and the ventilation provided must be suitable to the environment in which the server will be used.

If AC power supplies are installed:

Mains AC power disconnection: The AC power cord(s) is considered the mains disconnect for the server and must be readily accessible when installed. If the individual server power cord(s) will not be readily accessible for disconnection then you are responsible for installing an AC power disconnect for the entire rack unit. This main disconnect must be readily accessible, and it must be labeled as controlling power to the entire rack, not just to the server(s).

Grounding the rack installation: To avoid the potential for an electrical shock hazard, you must include a third wire safety ground conductor with the rack installation. If the server power cord is plugged into an AC outlet that is part of the rack, then you must provide proper grounding for the rack itself. If the server power cord is plugged into a wall AC outlet, the safety ground conductor in the power cord provides proper grounding only for the server. You must provide additional, proper grounding for the rack and other devices installed in it.

Over-current protection: The server is designed for an AC line voltage source with up to 20 amperes of over-current protection per cord feed. If the power system for the equipment rack is installed on a branch circuit with more than 20 amperes of protection, you must provide supplemental protection for the server.

If DC power supplies are installed:

Connection with a DC (Direct Current) source should only be performed by trained service personnel. The server with DC input is to be installed in a Restricted Access Location in accordance with articles 110-16, 110-17, and 110-18 of the National Electric Code, ANSI/NFPA 70. The DC source must be electrically isolated by double or reinforced insulation from any hazardous AC source.

Main DC power disconnect: You are responsible for installing a properly rated DC power disconnect for the server system. This mains disconnect must be readily accessible, and it must be labeled as controlling power to the server. The circuit breaker of a centralized DC power system may be used as a disconnect device when easily accessible and should be rated no more than 10 amps.

Grounding the server: To avoid the potential for an electrical shock hazard, you must reliably connect an earth grounding conductor to the server. The earth grounding conductor must be a minimum 18AWG connected to the earth ground stud(s) on the rear of the server. The safety ground conductor should be connected to the chassis stud with a Listed closed two-hole crimp terminal having 5/8 inch pitch. The nuts on the chassis earth ground studs should be installed with a 10 in/lbs torque. The safety ground conductor provides proper grounding only for the server. You must provide additional, proper grounding for the rack and other devices installed in it.

Over-current protection: Over-current protection circuit breakers must be provided as part of each host equipment rack and must be incorporated in the field wiring between the DC source and the server. The branch circuit protection shall be rated minimum 75Vdc, 10 A maximum per feed pair. If the DC power system for the equipment rack is installed with more than 10 amperes of protection, you must provide supplemental protection for the server.

13.4 Power Cord Usage Guidelines



WARNING

Do not attempt to modify or use an AC power cord set that is not the exact type required. You must use a power cord set that meets the following criteria:

- **Rating:** In the U.S. and Canada, cords must be UL (Underwriters Laboratories, Inc.) Listed/CSA (Canadian Standards Organization) Certified type SJT, 18-3 AWG (American Wire Gauge). Outside of the U.S. and Canada, cords must be flexible harmonized (<HAR>) or VDE (Verband Deutscher Elektrotechniker, German Institute of Electrical Engineers) certified cord with 3 x 0.75 mm conductors rated 250 VAC (Volts Alternating Current).
- **Connector, wall outlet end:** Cords must be terminated in grounding-type male plug designed for use in your region. The connector must have certification marks showing

certification by an agency acceptable in your region and for U.S. must be Listed and rated 125% of overall current rating of the server.

- Connector, server end: The connectors that plug into the AC receptacle on the server must be an approved IEC (International Electrotechnical Commission) 320, sheet C13, type female connector.
- Cord length and flexibility: Cords must be less than 4.5 meters (14.76 feet) long.

13.5 Electromagnetic Compatibility Notices

13.5.1 FCC Verification Statement (USA)

This device complies with Part 15 of the FCC Rules. Operation is subject to the following two conditions: (1) This device may not cause harmful interference, and (2) this device must accept any interference received, including interference that may cause undesired operation.

*Intel Corporation
5200 N.E. Elam Young Parkway
Hillsboro, OR 97124-6497
1-800-628-8686*

This equipment has been tested and found to comply with the limits for a Class A digital device, pursuant to Part 15 of the FCC Rules. These limits are designed to provide reasonable protection against harmful interference in a residential installation. This equipment generates, uses, and can radiate radio frequency energy and, if not installed and used in accordance with the instructions, may cause harmful interference to radio communications. However, there is no guarantee that interference will not occur in a particular installation. If this equipment does cause harmful interference to radio or television reception, which can be determined by turning the equipment off and on, the user is encouraged to try to correct the interference by one or more of the following measures:

- Reorient or relocate the receiving antenna.
- Increase the separation between the equipment and the receiver.
- Connect the equipment into an outlet on a circuit different from that to which the receiver is connected.
- Consult the dealer or an experienced radio/TV technician for help.

Any changes or modifications not expressly approved by the grantee of this device could void the user's authority to operate the equipment. The customer is responsible for ensuring compliance of the modified product.

Only peripherals (computer input/output devices, terminals, printers, etc.) that comply with FCC Class A or B limits may be attached to this computer product. Operation with noncompliant peripherals is likely to result in interference to radio and TV reception.

All cables used to connect to peripherals must be shielded and grounded. Operation with cables, connected to peripherals that are not shielded and grounded may result in interference to radio and TV reception.

13.5.2 ICES-003 (Canada)

Cet appareil numérique respecte les limites bruits radioélectriques applicables aux appareils numériques de Classe Aprescrites dans la norme sur le matériel brouilleur: "Appareils Numériques", NMB-003 édictée par le Ministre Canadian des Communications.

English translation of the notice above:

This digital apparatus does not exceed the Class A limits for radio noise emissions from digital apparatus set out in the interference-causing equipment standard entitled "Digital Apparatus," ICES-003 of the Canadian Department of Communications.

13.5.3 Europe (CE Declaration of Conformity)

This product has been tested in accordance too, and complies with the Low Voltage Directive (73/23/EEC) and EMC Directive (89/336/EEC). The product has been marked with the CE Mark to illustrate its compliance.

13.5.4 VCCI (Japan)

この装置は、情報処理装置等電波障害自主規制協議会（VCCI）の基準に基づくクラス A 情報技術装置です。この装置を家庭環境で使用すると電波妨害を引き起こすことがあります。この場合には使用者が適切な対策を講ずるよう要求されることがあります。

English translation of the notice above:

This is a Class A product based on the standard of the Voluntary Control Council for Interference (VCCI) from Information Technology Equipment. If this is used near a radio or television receiver in a domestic environment, it may cause radio interference. Install and use the equipment according to the instruction manual.

13.5.5 BSMI (Taiwan)

The BSMI Certification Marking and EMC warning is located on the outside rear area of the product.

警告使用者：
這是甲類的資訊產品，在居住的環境中使用時，可能會造成射頻干擾，在這種情況下，使用者會被要求採取某些適當的對策

13.5.6 KCC (Korea)

Following is the KCC certification information for Korea:



1. 기기의 명칭(모델명) :
2. 인증번호 :
3. 인증받은 자의 상호 :
4. 제조년월일:
5. 제조자/제조국가 :

English translation of the notice above:

1. Type of Equipment (Model Name): On Certification and Product
2. Certification No.: On KCC certificate. Obtain certificate from local Intel representative
3. Name of Certification Recipient: Intel Corporation
4. Date of Manufacturer: Refer to date code on product
5. Manufacturer/Nation: Intel Corporation/Refer to country of origin marked on product

13.6 Regulated Specified Components

To maintain the UL listing and compliance to other regulatory certifications and/or declarations, the following regulated components must be used and conditions adhered to. Interchanging or use of other component will void the UL listing and other product certifications and approvals.

Updated product information for configurations can be found on the Intel Server Builder Web site at the following URL:

<http://channel.intel.com/go/serverbuilder>

If you do not have access to Intel's Web address, please contact your local Intel representative.

- **Server chassis** (base chassis is provided with power supply and fans) — UL listed.
- **Server board** — you must use an Intel server board — UL recognized.
- **Add-in boards** — must have a printed wiring board flammability rating of minimum UL94V-1. Add-in boards containing external power connectors and/or lithium batteries must be UL recognized or UL listed. Any add-in board containing modem telecommunication circuitry must be UL listed. In addition, the modem must have the appropriate telecommunications, safety, and EMC approvals for the region in which it is sold.
- **Peripheral Storage Devices** — must be UL recognized or UL listed accessory and TUV or VDE licensed. Maximum power rating of any one device or combination of devices cannot exceed manufacturer's specifications. Total server configuration is not to exceed the maximum loading conditions of the power supply.

Appendix A: Integration and Usage Tips

This section provides a list of useful information that is unique to the Intel® Server System SR1625UR and should be kept in mind while integrating and configuring your Intel® Server Board S5520UR.

- Only low-profile (1.2 in or 30.48 mm) DIMMs can be used in the server system.
- Processor fans are not supported and are not needed in the server system. The system fan module and power supply fans provide the necessary cooling needed for the system. Using a processor fan in this system may cause Intel® System Management Software to incorrectly monitor the system fans.
- The CPU air duct, air baffle, and DIMM Blanks must be used to maintain system thermals.
- To maintain system thermals, all hard drive bays must be populated with either a hard drive or drive blank.
- System fans are not hot-swappable.
- Use of the screw found on the front edge of the top cover is required when the unit is installed in a user accessible environment.
- The FRUSDR utility must be run to load the proper Sensor Data Records for the server system onto the server board.
- Make sure the latest system software is loaded on the server. This includes system BIOS, FRUSDR, Integrated BMC firmware, and hot-swap controller firmware. The latest system software can be downloaded from <http://support.intel.com/support/motherboards/server/S5520UR/>.

Appendix B: POST Code Diagnostic LED Decoder

During the system boot process, the BIOS executes a number of platform configuration processes, each of which is assigned a specific hex POST code number. As each configuration routine is started, the BIOS displays the POST code to the POST Code Diagnostic LEDs on the back edge of the server board. To assist in troubleshooting a system hang during the POST process, the Diagnostic LEDs can be used to identify the last POST process that was executed.

Each POST code is represented by eight amber Diagnostic LEDs. The POST codes are divided into two nibbles, an upper nibble and a lower nibble. The upper nibble bits are represented by Diagnostic LEDs #4, #5, #6, #7. The lower nibble bits are represented by Diagnostics LEDs #0, #1, #2 and #3. If the bit is set in the upper and lower nibbles, the corresponding LED is lit. If the bit is clear, the corresponding LED is off.

The Diagnostic LED #7 is labeled as “MSB”, and the Diagnostic LED #0 is labeled as “LSB”.

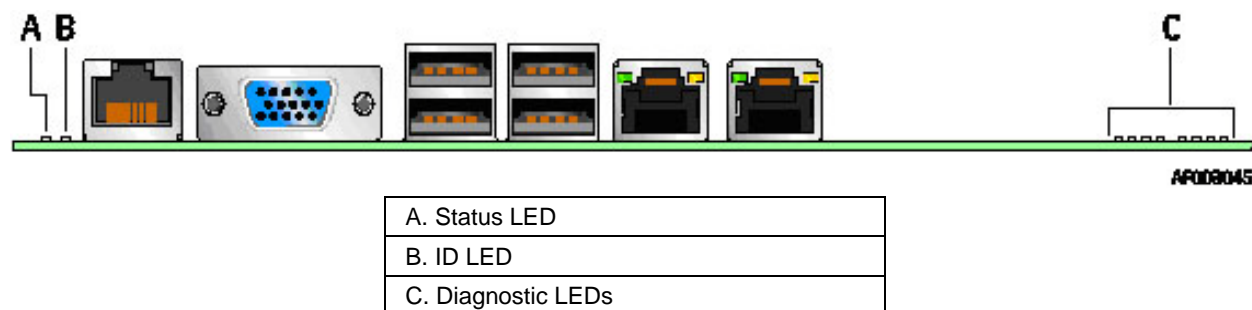

Figure 47. Diagnostic LED Placement Diagram

In the following example, the BIOS sends a value of ACh to the diagnostic LED decoder. The LEDs are decoded as follows:

Table 64. POST Progress Code LED Example

LEDs	Upper Nibble LEDs				Lower Nibble LEDs			
	MSB LED #7	LED #6	LED #5	LED #4	LED #3	LED #2	LED #1	LSB LED #0
	8h	4h	2h	1h	8h	4h	2h	1h
Status	ON	OFF	ON	OFF	ON	ON	OFF	OFF
Results	1	0	1	0	1	1	0	0
	Ah				Ch			

- Upper nibble bits = 1010b = Ah; Lower nibble bits = 1100b = Ch; the two are concatenated as ACh.

Table 65. Diagnostic LED POST Code Decoder

Checkpoint	Diagnostic LED Decoder								Description
	O = On, X=Off								
	Upper Nibble				Lower Nibble				
	MSB							LSB	
LED	8h	4h	2h	1h	8h	4h	2h	1h	
	#7	#6	#5	#4	#3	#2	#1	#0	
Multi-use code (This POST Code is used in different contexts)									
0xF2h	O	O	O	O	X	X	O	X	Seen at the start of Memory Reference Code (MRC) Start of the very early platform initialization code Very late in POST, it is the signal that the OS has switched to virtual memory mode
Memory Error Codes (Accompanied by a beep code)									
0xE8h	O	O	O	X	O	X	X	X	No Usable Memory Error: No memory in the system, or SPD bad so no memory could be detected
0xEAh	O	O	O	X	O	X	O	X	Channel Training Error: DQ/DQS training failed on a channel during memory channel initialization.
0xEBh	O	O	O	X	O	X	O	O	Memory Test Error: memory failed Hardware BIST.
0xEDh	O	O	O	X	O	O	X	O	Population Error: RDIMMs and UDIMMs cannot be mixed in the system
0xEEh	O	O	O	X	O	O	O	X	Mismatch Error: more than 2 Quad Ranked DIMMS in a channel.
Memory Reference Code Progress Codes (Not accompanied by a beep code)									
0xB0h	O	X	O	O	X	X	X	X	Chipset Initialization Phase
0xB1h	O	X	O	O	X	X	X	O	Reset Phase
0xB2h	O	X	O	O	X	X	O	X	DIMM Detection Phase
0xB3h	O	X	O	O	X	X	O	O	Clock Initialization Phase
0xB4h	O	X	O	O	X	O	X	X	SPD Data Collection Phase
0xB6h	O	X	O	O	X	O	O	X	Rank Formation Phase
0xB8h	O	X	O	O	O	X	X	X	Channel Training Phase
0xB9h	O	X	O	O	O	X	X	O	Memory Test Phase
0xBAh	O	X	O	O	O	X	O	X	Memory Map Creation Phase
0xBBh	O	X	O	O	O	X	O	O	RAS Initialization Phase
0xBFh	O	X	O	O	O	O	O	O	MRC Complete
Host Processor									
0x04h	X	X	X	X	X	O	X	X	Early processor initialization where system BSP is selected
0x10h	X	X	X	O	X	X	X	X	Power-on initialization of the host processor (bootstrap processor)
0x11h	X	X	X	O	X	X	X	O	Host processor cache initialization (including AP)
0x12h	X	X	X	O	X	X	O	X	Starting application processor initialization
0x13h	X	X	X	O	X	X	O	O	SMM initialization
Chipset									
0x21h	X	X	O	X	X	X	X	O	Initializing a chipset component
Memory									
0x22h	X	X	O	X	X	X	O	X	Reading configuration data from memory (SPD on DIMM)
0x23h	X	X	O	X	X	X	O	O	Detecting presence of memory
0x24h	X	X	O	X	X	O	X	X	Programming timing parameters in the memory controller
0x25h	X	X	O	X	X	O	X	O	Configuring memory parameters in the memory controller
0x26h	X	X	O	X	X	O	O	X	Optimizing memory controller settings
0x27h	X	X	O	X	X	O	O	O	Initializing memory, such as ECC init
0x28h	X	X	O	X	O	X	X	X	Testing memory
PCI Bus									
0x50h	X	O	X	O	X	X	X	X	Enumerating PCI busses

Checkpoint	Diagnostic LED Decoder								Description	
	0 = On, X=Off									
	Upper Nibble				Lower Nibble					
	MSB							LSB		
LED	8h	4h	2h	1h	8h	4h	2h	1h	#0	
0x51h	X	O	X	O	X	X	X	O	O	Allocating resources to PCI busses
0x52h	X	O	X	O	X	X	O	X	O	Hot Plug PCI controller initialization
0x53h	X	O	X	O	X	X	O	O	O	Reserved for PCI bus
0x54h	X	O	X	O	X	O	X	X	O	Reserved for PCI bus
0x55h	X	O	X	O	X	O	X	O	O	Reserved for PCI bus
0x56h	X	O	X	O	X	O	O	X	O	Reserved for PCI bus
0x57h	X	O	X	O	X	O	O	O	O	Reserved for PCI bus
USB										
0x58h	X	O	X	O	O	X	X	X	O	Resetting USB bus
0x59h	X	O	X	O	O	X	X	O	O	Reserved for USB devices
ATA/ATAPI/SATA										
0x5Ah	X	O	X	O	O	X	O	X	O	Resetting SATA bus and all devices
0x5Bh	X	O	X	O	O	X	O	O	O	Reserved for ATA
SMBUS										
0x5Ch	X	O	X	O	O	O	X	X	O	Resetting SMBUS
0x5Dh	X	O	X	O	O	O	X	O	O	Reserved for SMBUS
Local Console										
0x70h	X	O	O	O	X	X	X	X	O	Resetting the video controller (VGA)
0x71h	X	O	O	O	X	X	X	O	O	Disabling the video controller (VGA)
0x72h	X	O	O	O	X	X	O	X	O	Enabling the video controller (VGA)
Remote Console										
0x78h	X	O	O	O	O	X	X	X	O	Resetting the console controller
0x79h	X	O	O	O	O	X	X	O	O	Disabling the console controller
0x7Ah	X	O	O	O	O	X	O	X	O	Enabling the console controller
Keyboard (only USB)										
0x90h	O	X	X	O	X	X	X	X	O	Resetting the keyboard
0x91h	O	X	X	O	X	X	X	O	O	Disabling the keyboard
0x92h	O	X	X	O	X	X	O	X	O	Detecting the presence of the keyboard
0x93h	O	X	X	O	X	X	O	O	O	Enabling the keyboard
0x94h	O	X	X	O	X	O	X	X	O	Clearing keyboard input buffer
0x95h	O	X	X	O	X	O	X	O	O	Instructing keyboard controller to run Self Test (PS2 only)
Mouse (only USB)										
0x98h	O	X	X	O	O	X	X	X	O	Resetting the mouse
0x99h	O	X	X	O	O	X	X	O	O	Detecting the mouse
0x9Ah	O	X	X	O	O	X	O	X	O	Detecting the presence of mouse
0x9Bh	O	X	X	O	O	X	O	O	O	Enabling the mouse
Fixed Media										
0xB0h	O	X	O	O	X	X	X	X	O	Resetting fixed media device
0xB1h	O	X	O	O	X	X	X	O	O	Disabling fixed media device
0xB2h	O	X	O	O	X	X	O	X	O	Detecting presence of a fixed media device (hard drive detection, etc.)
0xB3h	O	X	O	O	X	X	O	O	O	Enabling/configuring a fixed media device
Removable Media										
0xB8h	O	X	O	O	O	X	X	X	O	Resetting removable media device
0xB9h	O	X	O	O	O	X	X	O	O	Disabling removable media device

Checkpoint	Diagnostic LED Decoder								Description
	O = On, X=Off								
	Upper Nibble				Lower Nibble				
	MSB							LSB	
LED	8h	4h	2h	1h	8h	4h	2h	1h	
	#7	#6	#5	#4	#3	#2	#1	#0	
0xBAh	O	X	O	O	O	X	O	X	Detecting presence of a removable media device (CDROM detection, etc.)
0xBCh	O	X	O	O	O	O	X	X	Enabling/configuring a removable media device
Boot Device Selection (BDS)									
0xD0	O	O	X	O	X	X	X	X	Trying to boot device selection 0
0xD1	O	O	X	O	X	X	X	O	Trying to boot device selection 1
0xD2	O	O	X	O	X	X	O	X	Trying to boot device selection 2
0xD3	O	O	X	O	X	X	O	O	Trying to boot device selection 3
0xD4	O	O	X	O	X	O	X	X	Trying to boot device selection 4
0xD5	O	O	X	O	X	O	X	O	Trying to boot device selection 5
0xD6	O	O	X	O	X	O	O	X	Trying to boot device selection 6
0xD7	O	O	X	O	X	O	O	O	Trying to boot device selection 7
0xD8	O	O	X	O	O	X	X	X	Trying to boot device selection 8
0xD9	O	O	X	O	O	X	X	O	Trying to boot device selection 9
0xDA	O	O	X	O	O	X	O	X	Trying to boot device selection A
0xDB	O	O	X	O	O	X	O	O	Trying to boot device selection B
0xDC	O	O	X	O	O	O	X	X	Trying to boot device selection C
0xDD	O	O	X	O	O	O	X	O	Trying to boot device selection D
0xDE	O	O	X	O	O	O	O	X	Trying to boot device selection E
0xDF	O	O	X	O	O	O	O	O	Trying to boot device selection F
Pre-EFI Initialization (PEI) Core									
0xE0h	O	O	O	X	X	X	X	X	Started dispatching early initialization modules (PEIM)
0xE1h	O	O	O	X	X	X	X	O	Reserved for initialization module use (PEIM)
0xE2h	O	O	O	X	X	X	O	X	Initial memory found, configured, and installed correctly
0xE3h	O	O	O	X	X	X	O	O	Reserved for initialization module use (PEIM)
Driver eXecution Environment (DXE) Core (not accompanied by a beep code)									
0xE4h	O	O	O	X	X	O	X	X	Entered EFI driver execution phase (DXE)
0xE5h	O	O	O	X	X	O	X	O	Started dispatching drivers
0xE6h	O	O	O	X	X	O	O	X	Started connecting drivers
DXE Drivers									
0xE7h	O	O	O	X	O	O	X	O	Waiting for user input
0xE8h	O	O	O	X	O	X	X	X	Checking password
0xE9h	O	O	O	X	O	X	X	O	Entering BIOS setup
0xEAh	O	O	O	X	O	X	O	X	Flash Update
0xEEh	O	O	O	X	O	O	O	X	Calling Int 19. One beep unless silent boot is enabled.
0xEFh	O	O	O	X	O	O	O	O	Unrecoverable boot failure
Runtime Phase/EFI Operating System Boot									
0xF2h	O	O	O	O	X	X	O	X	Signal that the OS has switched to virtual memory mode
0xF4h	O	O	O	O	X	O	X	X	Entering Sleep state
0xF5h	O	O	O	O	X	O	X	O	Exiting Sleep state
0xF8h	O	O	O	O	O	X	X	X	OS has requested EFI to close boot services (ExitBootServices () Has been called)

Checkpoint	Diagnostic LED Decoder								Description
	O = On, X=Off								
	Upper Nibble				Lower Nibble				
	MSB							LSB	
	8h	4h	2h	1h	8h	4h	2h	1h	
LED	#7	#6	#5	#4	#3	#2	#1	#0	
0xF9h	O	O	O	O	O	X	X	O	OS has switched to virtual address mode (SetVirtualAddressMap () Has been called)
0xFAh	O	O	O	O	O	X	O	X	OS has requested the system to reset (ResetSystem () has been called)
Pre-EFI Initialization Module (PEIM)/Recovery									
0x30h	X	X	O	O	X	X	X	X	Crisis recovery has been initiated because of a user request
0x31h	X	X	O	O	X	X	X	O	Crisis recovery has been initiated by software (corrupt flash)
0x34h	X	X	O	O	X	O	X	X	Loading crisis recovery capsule
0x35h	X	X	O	O	X	O	X	O	Handing off control to the crisis recovery capsule
0x3Fh	X	X	O	O	O	O	O	O	Unable to complete crisis recovery capsule

Appendix C: POST Code Errors

Whenever possible, the BIOS outputs the current boot progress codes on the video screen. Progress codes are 32-bit quantities plus optional data. The 32-bit numbers include class, subclass, and operation information. The class and subclass fields point to the type of hardware that is being initialized. The operation field represents the specific initialization activity. Based on the data bit availability to display progress codes, a progress code can be customized to fit the data width. The higher the data bit, the higher the granularity of information that can be sent on the progress port. The progress codes may be reported by the system BIOS or option ROMs.

The Response section in the following table is divided into three types:

- **No Pause:** The message is displayed on the screen during POST or on the Error Manager screen. The system continues booting with a degraded state. The user may want to replace the erroneous unit. The setup POST error Pause setting does not have any effect with this error.
- **Pause:** The message is displayed on the Error Manager screen, and an error is logged to the SEL. The setup POST error Pause setting determines whether the system pauses to the Error Manager for this type of error, where the user can take immediate corrective action or choose to continue booting.
- **Halt:** The message is displayed on the Error Manager screen, an error is logged to the SEL, and the system cannot boot unless the error is resolved. The user needs to replace the faulty part and restart the system. The setup POST error Pause setting does not have any effect with this error.

Table 66. POST Error Messages and Handling

Error Code	Error Message	Response
0012	CMOS date/time not set.	Pause
0048	Password check failed.	Halt
0108	Keyboard component encountered a locked error.	No Pause
0109	Keyboard component encountered a stuck key error.	No Pause
0113	Fixed Media The SAS RAID firmware cannot run properly. The user should attempt to re-flash the firmware.	Pause
0140	PCI component encountered a PERR error.	Pause
0141	PCI resource conflict.	Pause
0146	PCI out of resources error.	Pause
0192	L3 cache size mismatch.	Halt
0194	CPUID, processor family are different.	Halt
0195	Front side bus mismatch.	Pause
0196	Processor Model mismatch.	Pause
0197	Processor speeds mismatched.	Pause
0198	Processor family is unsupported.	Pause
019F	Processor and chipset stepping configuration is unsupported.	Pause
5220	CMOS/NVRAM Configuration Cleared.	Pause
5221	Passwords cleared by jumper.	Pause
5224	Password clear Jumper is Set.	Pause
8110	Processor 01 internal error (IERR) on last boot.	Pause
8111	Processor 02 internal error (IERR) on last boot.	Pause
8120	Processor 01 thermal trip error on last boot.	Pause
8121	Processor 02 thermal trip error on last boot.	Pause
8130	Processor 01 disabled.	Pause

Error Code	Error Message	Response
8131	Processor 02 disabled.	Pause
8140	Processor 01 Failed FRB-3 Timer.	No Pause
8141	Processor 02 Failed FRB-3 Timer.	No Pause
8160	Processor 01 unable to apply BIOS update.	Pause
8161	Processor 02 unable to apply BIOS update.	Pause
8170	Processor 01 failed Self Test (BIST).	Pause
8171	Processor 02 failed Self Test (BIST).	Pause
8180	Processor 01 BIOS does not support the current stepping for processor.	No Pause
8181	Processor 02 BIOS does not support the current stepping for processor.	No Pause
8190	Watchdog timer failed on last boot.	Pause
8198	Operating system boot watchdog timer expired on last boot.	Pause
8300	Integrated Baseboard Management Controller failed self-test.	Pause
84F2	Integrated Baseboard Management Controller failed to respond.	Pause
84F3	Integrated Baseboard Management Controller in update mode.	Pause
84F4	Sensor data record empty.	Pause
84FF	System event log full.	No Pause
8500	Memory component could not be configured in the selected RAS mode.	Pause
8520	DIMM_A1 failed Self Test (BIST).	Pause
8521	DIMM_A2 failed Self Test (BIST).	Pause
8522	DIMM_A3 failed Self Test (BIST).	Pause
8523	DIMM_A4 failed Self Test (BIST).	Pause
8524	DIMM_B1 failed Self Test (BIST).	Pause
8525	DIMM_B2 failed Self Test (BIST).	Pause
8526	DIMM_B3 failed Self Test (BIST).	Pause
8527	DIMM_B4 failed Self Test (BIST).	Pause
8528	DIMM_C1 failed Self Test (BIST).	Pause
8529	DIMM_C2 failed Self Test (BIST).	Pause
852A	DIMM_C3 failed Self Test (BIST).	Pause
852B	DIMM_C4 failed Self Test (BIST).	Pause
852C	DIMM_D1 failed Self Test (BIST).	Pause
852D	DIMM_D2 failed Self Test (BIST).	Pause
852E	DIMM_D3 failed Self Test (BIST).	Pause
852F	DIMM_D4 failed Self Test (BIST).	Pause
8540	DIMM_A1 Disabled.	Pause
8541	DIMM_A2 Disabled.	Pause
8542	DIMM_A3 Disabled.	Pause
8543	DIMM_A4 Disabled.	Pause
8544	DIMM_B1 Disabled.	Pause
8545	DIMM_B2 Disabled.	Pause
8546	DIMM_B3 Disabled.	Pause
8547	DIMM_B4 Disabled.	Pause
8548	DIMM_C1 Disabled.	Pause
8549	DIMM_C2 Disabled.	Pause
854A	DIMM_C3 Disabled.	Pause
854B	DIMM_C4 Disabled.	Pause
854C	DIMM_D1 Disabled.	Pause
854D	DIMM_D2 Disabled.	Pause
854E	DIMM_D3 Disabled.	Pause
854F	DIMM_D4 Disabled.	Pause
8560	DIMM_A1 Component encountered a Serial Presence Detection (SPD) fail error.	Pause
8561	DIMM_A2 Component encountered a Serial Presence Detection (SPD) fail error.	Pause
8562	DIMM_A3 Component encountered a Serial Presence Detection (SPD) fail error.	Pause
8563	DIMM_A4 Component encountered a Serial Presence Detection (SPD) fail error.	Pause
8564	DIMM_B1 Component encountered a Serial Presence Detection (SPD) fail error.	Pause
8565	DIMM_B2 Component encountered a Serial Presence Detection (SPD) fail error.	Pause
8566	DIMM_B3 Component encountered a Serial Presence Detection (SPD) fail error.	Pause

Error Code	Error Message	Response
8567	DIMM_B4 Component encountered a Serial Presence Detection (SPD) fail error.	Pause
8568	DIMM_C1 Component encountered a Serial Presence Detection (SPD) fail error.	Pause
8569	DIMM_C2 Component encountered a Serial Presence Detection (SPD) fail error.	Pause
856A	DIMM_C3 Component encountered a Serial Presence Detection (SPD) fail error.	Pause
856B	DIMM_C4 Component encountered a Serial Presence Detection (SPD) fail error.	Pause
856C	DIMM_D1 Component encountered a Serial Presence Detection (SPD) fail error.	Pause
856D	DIMM_D2 Component encountered a Serial Presence Detection (SPD) fail error.	Pause
856E	DIMM_D3 Component encountered a Serial Presence Detection (SPD) fail error.	Pause
856F	DIMM_D4 Component encountered a Serial Presence Detection (SPD) fail error.	Pause
8580	DIMM_A1 Correctable ECC error encountered.	Pause after 10 Occurrence
8581	DIMM_A2 Correctable ECC error encountered.	Pause after 10 Occurrence
8582	DIMM_A3 Correctable ECC error encountered.	Pause after 10 Occurrence
8583	DIMM_A4 Correctable ECC error encountered.	Pause after 10 Occurrence
8584	DIMM_B1 Correctable ECC error encountered.	Pause after 10 Occurrence
8585	DIMM_B2 Correctable ECC error encountered.	Pause after 10 Occurrence
8586	DIMM_B3 Correctable ECC error encountered.	Pause after 10 Occurrence
8587	DIMM_B4 Correctable ECC error encountered.	Pause after 10 Occurrence
8588	DIMM_C1 Correctable ECC error encountered.	Pause after 10 Occurrence
8589	DIMM_C2 Correctable ECC error encountered.	Pause after 10 Occurrence
858A	DIMM_C3 Correctable ECC error encountered.	Pause after 10 Occurrence
858B	DIMM_C4 Correctable ECC error encountered.	Pause after 10 Occurrence
858C	DIMM_D1 Correctable ECC error encountered.	Pause after 10 Occurrence
858D	DIMM_D2 Correctable ECC error encountered.	Pause after 10 Occurrence
858E	DIMM_D3 Correctable ECC error encountered.	Pause after 10 Occurrence
858F	DIMM_D4 Correctable ECC error encountered.	Pause after 10 Occurrence
85A0	DIMM_A1 Uncorrectable ECC error encountered.	Pause
85A1	DIMM_A2 Uncorrectable ECC error encountered.	Pause
85A2	DIMM_A3 Uncorrectable ECC error encountered.	Pause
85A3	DIMM_A4 Uncorrectable ECC error encountered.	Pause
85A4	DIMM_B1 Uncorrectable ECC error encountered.	Pause
85A5	DIMM_B2 Uncorrectable ECC error encountered.	Pause
85A6	DIMM_B3 Uncorrectable ECC error encountered.	Pause
85A7	DIMM_B4 Uncorrectable ECC error encountered.	Pause
85A8	DIMM_C1 Uncorrectable ECC error encountered.	Pause
85A9	DIMM_C2 Uncorrectable ECC error encountered.	Pause
85AA	DIMM_C3 Uncorrectable ECC error encountered.	Pause
85AB	DIMM_C4 Uncorrectable ECC error encountered.	Pause
85AC	DIMM_D1 Uncorrectable ECC error encountered.	Pause
85AD	DIMM_D2 Uncorrectable ECC error encountered.	Pause
85AE	DIMM_D3 Uncorrectable ECC error encountered.	Pause
85AF	DIMM_D4 Uncorrectable ECC error encountered.	Pause
8601	Override jumper is set to force boot from lower alternate BIOS bank of flash ROM.	No Pause
8602	WatchDog timer expired (secondary BIOS may be bad!).	No Pause
8603	Secondary BIOS checksum fail.	No Pause
8604	Chipset Reclaim of non critical variables complete.	No Pause
9000	Unspecified processor component has encountered a non specific error.	Pause
9223	Keyboard component was not detected.	No Pause
9226	Keyboard component encountered a controller error.	No Pause
9243	Mouse component was not detected.	No Pause
9246	Mouse component encountered a controller error.	No Pause
9266	Local Console component encountered a controller error.	No Pause
9268	Local Console component encountered an output error.	No Pause
9269	Local Console component encountered a resource conflict error.	No Pause
9286	Remote Console component encountered a controller error.	No Pause
9287	Remote Console component encountered an input error.	No Pause
9288	Remote Console component encountered an output error.	No Pause

Error Code	Error Message	Response
92A3	Serial port component was not detected	Pause
92A9	Serial port component encountered a resource conflict error	Pause
92C6	Serial Port controller error	No Pause
92C7	Serial Port component encountered an input error.	No Pause
92C8	Serial Port component encountered an output error.	No Pause
94C6	LPC component encountered a controller error.	No Pause
94C9	LPC component encountered a resource conflict error.	Pause
9506	ATA/ATPI component encountered a controller error.	No Pause
95A6	PCI component encountered a controller error.	No Pause
95A7	PCI component encountered a read error.	No Pause
95A8	PCI component encountered a write error.	No Pause
9609	Unspecified software component encountered a start error.	No Pause
9641	PEI Core component encountered a load error.	No Pause
9667	PEI module component encountered an illegal software state error.	Halt
9687	DXE core component encountered an illegal software state error.	Halt
96A7	DXE boot services driver component encountered an illegal software state error.	Halt
96AB	DXE boot services driver component encountered invalid configuration.	No Pause
96E7	SMM driver component encountered an illegal software state error.	Halt
0xA022	Processor component encountered a mismatch error.	Pause
0xA027	Processor component encountered a low voltage error.	No Pause
0xA028	Processor component encountered a high voltage error.	No Pause
0xA421	PCI component encountered a SERR error.	Halt
0xA500	ATA/ATPI ATA bus SMART not supported.	No Pause
0xA501	ATA/ATPI ATA SMART is disabled.	No Pause
0xA5A0	PCI Express* component encountered a PERR error.	No Pause
0xA5A1	PCI Express* component encountered a SERR error.	Halt
0xA5A4	PCI Express* IBIST error.	Pause
0xA6A0	DXE boot services driver Not enough memory available to shadow a legacy option ROM.	No Pause

POST Error Beep Codes

The following table lists POST error beep codes. Prior to system video initialization, the BIOS uses these beep codes to inform users on error conditions. The beep code is followed by a user-visible code on POST progress LEDs. For complete details, refer to the *Intel® S5500/S5520 Server Board Family BIOS External Product Specification*.

Table 67. POST Error Beep Codes

Beeps	Error Message	POST Progress Code	Description
3	Memory error	0xE8, 0xEB, 0xED, 0xEE	System halted because a fatal error related to the memory was detected.

The Integrated BMC may generate beep codes upon detection of failure conditions. Beep codes are sounded each time the problem is discovered, such as on each power-up attempt, but are not sounded continuously. Codes that are common across all Intel® Server Boards and Systems that use same generation chipset are listed in the following table. Each digit in the code is represented by a sequence of beeps whose count is equal to the digit. For complete details, refer to the *Intel® Server System Integrated Baseboard Management Controller Core External Product Specification*.

Table 68. Integrated BMC Beep Codes

Code	Reason for Beep	Associated Sensors	Supported?
1-5-2-1	CPU: Empty slot/population error – Processor slot 1 is not populated.	CPU Population Error	Yes
1-5-4-2	Power fault: DC power unexpectedly lost (power good dropout).	Power Unit – power unit failure offset	Yes
1-5-4-4	Power control fault.	Power Unit – soft power control failure offset	Yes

Glossary

Word/Acronym	Definition
ACA	Australian Communication Authority
ANSI	American National Standards Institute
BMC	Baseboard Management Controller
BIOS	Basic Input/Output System
CMOS	Complementary Metal-oxide-semiconductor
D2D	DC-to-DC
EMP	Emergency Management Port
FP	Front Panel
FRB	Fault Resilient Boot
FRU	Field Replaceable Unit
I ² C	Inter-integrated Circuit bus
LCD	Liquid Crystal Display
LPC	Low-pin Count
LSB	Least Significant Bit
MSB	Most Significant Bit
MTBF	Mean Time Between Failure
MTTR	Mean Time to Repair
NIC	Network Interface Card
NMI	Non-maskable Interrupt
OTP	Over-temperature Protection
OVP	Over-voltage Protection
PCI	Peripheral Component Interconnect
PCB	Printed Circuit Board
PCIe*	Peripheral Component Interconnect Express*
PCI-X	Peripheral Component Interconnect Extended
PFC	Power Factor Correction
POST	Power-on Self Test
PSU	Power Supply Unit
RAM	Random Access Memory
RI	Ring Indicate
SCA	Single Connector Attachment
SDR	Sensor Data Record
SE	Single-Ended
THD	Total Harmonic Distortion
UART	Universal Asynchronous Receiver Transmitter
USB	Universal Serial Bus
VCCI	Voluntary Control Council for Interference
VS	Voltage Standby

Reference Documents

See the following documents for additional information:

- *Intel® Server Board S5520UR Technical Product Specification*
- *Intel® Server System SR1625UR AC Power Supply Module Specification*
- *Intel® Server Board S5520UR/Intel® Server System SR1625UR Spares/Parts List and Configuration Guide*
- *Intel® Server System SR1625UR Service Guide*
- *Intel® S5500/S5520 Server Board Family BIOS External Product Specification*
- *Intel® Server System Integrated Baseboard Management Controller Core External Product Specification*