

# Intel® Server System H2000WP Family

## *Technical Product Specification*

*Intel order number: G52418-001*



**Revision 1.0**

**January, 2012**

**Enterprise Platforms and Services Division**

## ***Revision History***

Date	Revision Number	Modifications
January, 2012	1.0	Initial release.

## ***Disclaimers***

Information in this document is provided in connection with Intel® products. No license, express or implied, by estoppel or otherwise, to any intellectual property rights is granted by this document. Except as provided in Intel's Terms and Conditions of Sale for such products, Intel® assumes no liability whatsoever, and Intel® disclaims any express or implied warranty, relating to sale and/or use of Intel® products including liability or warranties relating to fitness for a particular purpose, merchantability, or infringement of any patent, copyright or other intellectual property right. Intel® products are not intended for use in medical, lifesaving, or life sustaining applications. Intel® may make changes to specifications and product descriptions at any time, without notice.

Designers must not rely on the absence or characteristics of any features or instructions marked "reserved" or "undefined". Intel® reserves these for future definition and shall have no responsibility whatsoever for conflicts or incompatibilities arising from future changes to them.

The Intel® Server System H2000WP Family may contain design defects or errors known as errata which may cause the product to deviate from published specifications. Current characterized errata are available on request.

This document and the software described in it is furnished under license and may only be used or copied in accordance with the terms of the license. The information in this manual is furnished for informational use only, is subject to change without notice, and should not be construed as a commitment by Intel Corporation. Intel Corporation assumes no responsibility or liability for any errors or inaccuracies that may appear in this document or any software that may be provided in association with this document.

Except as permitted by such license, no part of this document may be reproduced, stored in a retrieval system, or transmitted in any form or by any means without the express written consent of Intel Corporation.

Intel, Pentium and Xeon are trademarks or registered trademarks of Intel Corporation.

\*Other brands and names may be claimed as the property of others.

Copyright © Intel Corporation 2012. Portions Copyright © 2012 by LSI\* Corporation and Mellanox\* Corporation.

# ***Table of Contents***

<b>1. Introduction .....</b>	<b>1</b>
1.1 Chapter Outline.....	1
1.2 Server Board Use Disclaimer .....	2
<b>2. Product Overview.....</b>	<b>3</b>
2.1 System Views .....	5
2.2 System Dimensions .....	5
2.3 Hard Drive and Peripheral Bays .....	6
2.4 Server Board Overview.....	6
2.5 Front Bezel Support.....	9
2.6 Rack and Cabinet Mounting Options .....	9
<b>3. Power Sub-System.....</b>	<b>10</b>
3.1 Mechanical Overview.....	10
3.1.1 AC Power Supply Unit Dimension Overview .....	10
3.1.2 AC input connector .....	10
3.1.3 AC Power Cord Specification Requirements .....	11
3.1.4 Power Supply Unit DC Output Connector.....	11
3.1.5 Handle Retention .....	12
3.1.6 LED Marking and Identification.....	12
3.1.7 Power Cage with Power Distribution Board.....	12
3.1.8 Power Cage Output Pin Assignment .....	13
3.2 AC Input Specification .....	15
3.2.1 Input Voltage And Frequency .....	15
3.2.2 AC input Power Factor.....	15
3.2.3 Efficiency .....	15
3.2.4 AC Line Fuse .....	16
3.2.5 AC Line Inrush .....	16
3.2.6 AC Line Dropout/Holdup.....	16
3.2.7 AC Line Fast Transient (EFT) Specification .....	17
3.2.8 Hot Plug.....	17
3.2.9 Susceptability Requirements .....	17
3.2.10 Electrostatic Discharge Susceptibility .....	17
3.2.11 Fast Transient/Burst .....	17
3.2.12 Radiated Immunity.....	17
3.2.13 Surge Immunity.....	17
3.2.14 AC Line Transient Specification.....	18
3.2.15 Power recovery.....	18
3.2.16 Voltage Interruptions.....	18
3.2.17 AC Line Isolation.....	18
3.2.18 AC Power Inlet.....	19

3.3	DC Output Specification .....	19
3.3.1	Output Power/Currents .....	19
3.3.2	Standby Output.....	19
3.3.3	Voltage Regulation .....	20
3.3.4	Dynamic Loading .....	20
3.3.5	Capacitive Loading .....	20
3.3.6	Ripple/Noise .....	20
3.3.7	Grounding .....	21
3.3.8	Closed Loop Stability .....	21
3.3.9	Residual Voltage Immunity in Standby Mode .....	21
3.3.10	Common Mode Noise .....	21
3.3.11	Soft Starting .....	21
3.3.12	Zero Load Stability Requirement .....	21
3.3.13	Hot Swap Requirement.....	22
3.3.14	Forced Load Sharing .....	22
3.3.15	Timing Requirement .....	22
3.4	Power Supply Cold Redundancy Support .....	23
3.4.1	1200W CRPS Cold Redundancy.....	24
3.4.2	1600W CRPS Cold Redundancy.....	24
3.5	Control And Indicator Functions .....	24
3.5.1	PSON# Input Signal.....	24
3.5.2	PWOK(power good) Output Signal.....	25
3.5.3	SMBAlert# Signal.....	25
3.6	Protection circuits .....	26
3.6.1	Current Limit (OCP) .....	26
3.6.2	Over Voltage Protection (OVP).....	26
3.6.3	Over Thermal protection .....	26
3.7	PMBus* .....	27
3.7.1	PSU Address Lines A0 .....	27
3.7.2	Accuracy .....	28
<b>4.</b>	<b>Cooling Sub-System .....</b>	<b>29</b>
4.1	Processor Heatsink.....	29
4.2	Node cooling Fans .....	30
4.3	Power Supply Fan .....	32
4.4	Air Duct Module .....	32
4.5	Drive Bay Population Requirement.....	32
<b>5.</b>	<b>System Boards in the Node Tray .....</b>	<b>33</b>
5.1	Node Docking Board.....	33
5.1.1	Overview of Node Docking Board.....	33
5.1.2	Pinout definition on Node Docking Board .....	34
5.2	Bridge Board .....	35

5.2.1	Overview of Bridge Board .....	35
5.2.2	Pinout definition on Bridge Board .....	36
<b>6.</b>	<b>Hard Disk Drive Support.....</b>	<b>39</b>
6.1	Hard Disk Drive Bays Scheme .....	39
6.2	Hard Drive Carrier.....	39
6.3	Hot-Swap Hard Drive Support .....	40
6.3.1	Backplane Feature set:.....	41
6.3.2	Backplane Block Diagram.....	42
6.3.3	3.5" Hot Swap Backplane Connector scheme .....	42
6.3.4	2.5" Hot Swap Backplane Connector scheme .....	43
6.3.5	Backplane LED Support .....	44
6.3.6	Backplane Connector Definition .....	45
<b>7.</b>	<b>Front Panel Control and Indicators .....</b>	<b>49</b>
7.1	Control Panel Button.....	50
7.2	Control Panel LED Indicators .....	50
7.2.1	Power/Sleep LED .....	51
7.2.2	System Status LED.....	51
7.2.3	System Status LED – BMC Initialization .....	52
<b>8.</b>	<b>Configuration Jumpers.....</b>	<b>53</b>
8.1	Force Integrated BMC Update (J6B1) .....	54
8.2	Force ME Update (J1E2).....	55
8.3	Password Clear (J1E3).....	56
8.4	BIOS Recovery Mode (J1E1) .....	56
8.5	Reset BIOS Settings (J1D5).....	57
<b>9.</b>	<b>PCI Express Riser Card and Assembly.....</b>	<b>59</b>
9.1	PCI Express Riser for Slot 1 .....	59
9.1.1	Overview of PCI-Express Riser .....	59
9.1.2	Pinout definition on Slot 1 Riser.....	59
9.2	PCI Express Riser with IOM Carrier for Slot 2 (Optional) .....	64
9.2.1	Overview of PCI-E Riser with IOM Carrier.....	64
9.2.2	Pinout definition on Slot 2 Riser and IOM Carrier.....	65
<b>Appendix A: Integration and Usage Tips.....</b>		<b>71</b>
<b>Appendix B: POST Code LED Decoder .....</b>		<b>72</b>
<b>Appendix C: Video POST Code Errors .....</b>		<b>76</b>
<b>Glossary.....</b>		<b>81</b>
<b>Reference Documents .....</b>		<b>84</b>

## **List of Figures**

Figure 1. System Overview (Air Duct is removed) .....	5
Figure 2. Compute Node Scheme (Rear View) .....	5
Figure 3. Intel® Server System H2312WP Drive Bay Overview .....	6
Figure 4. Intel® Server System H2216WP Drive Bay Overview .....	6
Figure 5. Intel® Server Board S2600WPQ .....	7
Figure 6. Intel® Server Board S2600WP Components.....	8
Figure 7. Back Panel Feature Overview .....	8
Figure 8. Light-Guided Diagnostic LED Locations .....	9
Figure 9. System Bezel Front View.....	9
Figure 10. AC Power Supply Unit Dimension Overview .....	10
Figure 11. Power Cage Overview .....	13
Figure 12. Power distribution board .....	14
Figure 13. AC Power Cord Specification .....	19
Figure 14. Turn On/Off Timing (Power Supply Signals).....	23
Figure 15. Power Supply Device Address .....	27
Figure 16. PMBus Monitoring Accuracy.....	28
Figure 17. Processor Heatsink Overview.....	30
Figure 18. Node Fan Set and power/control Connection.....	31
Figure 19. Compute Node Air Duct.....	32
Figure 20. Compute Node Tray Overview .....	33
Figure 21. Node Docking Board.....	33
Figure 22. Bridge Board Overview .....	35
Figure 23. Connectors on Bridge Board .....	36
Figure 24. HDD Scheme for H2312WPGR.....	39
Figure 25. HDD Scheme for H2216WPGR.....	39
Figure 26. 3.5-inch HDD Assembly Overview.....	40
Figure 27. 2.5-inch HDD Assembly Overview.....	40
Figure 28. Passive Backplane Block Diagram (for one node) .....	42
Figure 29. 3.5" Backplane Component and Connectors (Front View) .....	42
Figure 30. 3.5" Backplane Component and Connectors (Back View).....	43
Figure 31. 2.5" Backplane Component and Connectors (Front View) .....	44
Figure 32. 2.5" Backplane Component and Connectors (Back View).....	44
Figure 33. Hard Drive Carrier LED.....	45
Figure 34. Front Control Panel.....	49
Figure 35. Jumper Locations and Functions .....	53
Figure 36. PCI Express Riser for Riser Slot 1.....	59
Figure 37. PCI Express Riser with bracket for Riser Slot 2 .....	64
Figure 38. IOM Carrier .....	64
Figure 39. Diagnostic LED location.....	72

## **List of Tables**

Table 1. System Feature Set .....	3
Table 2. System SKU matrix.....	4
Table 3. Chassis Dimension (SKU: H2312WPGR).....	5
Table 4. Chassis Dimension (SKU: H2216WPGR).....	6
Table 5. AC power cord specification .....	11
Table 6. DC Output Power Connector .....	11
Table 7. Power Supply Status LED.....	12
Table 8. Pin assignment of power output connector.....	14
Table 9. Pin assignment of control signal connector .....	14
Table 10. AC input rating.....	15
Table 11. Typical power factor.....	15
Table 12. Platinum Efficiency Requirement .....	16
Table 13. AC Power Holdup Requirement.....	16
Table 14. Performance Criteria.....	17
Table 15. AC Line Sag Transient Performance .....	18
Table 16. AC Line Surge Transient Performance .....	18
Table 17. Load Ratings for single power supply unit .....	19
Table 18. Voltage Regulation Limits .....	20
Table 19. Transient Load Requirements.....	20
Table 20. Capacitive Loading Conditions .....	20
Table 21. Ripple and Noise.....	20
Table 22. Timing Requirement.....	22
Table 23. 1200W CRPS Cold Redundancy Threshold.....	24
Table 24. 1600W CRPS Cold Redundancy Threshold.....	24
Table 25. PSON# Signal Characteristics.....	24
Table 26. PWOK Signal Characteristics .....	25
Table 27. SMBAlert# Signal Characteristics .....	25
Table 28. Over Current Protection .....	26
Table 29. Over Voltage Protection (OVP) Limits .....	26
Table 30. PSU addressing .....	27
Table 31. PMBus Accuracy.....	28
Table 32. 8-pin Connector Pin-Out for Node Dual Rotor Fans .....	31
Table 33. Main Power Input Connector .....	34
Table 34. Fan Control Signal Connector.....	34
Table 35. Node Fan Connector.....	34
Table 36. Main Power Output Connector.....	35
Table 37. Card Edge Connector Pinout .....	37
Table 38. AHCI SATA0 DOM Connector Pinout.....	38
Table 39. USB 2.0 Type-A Connector Pinout .....	38



Table 40. 5V_AUX Power Connector Pinout .....	38
Table 41. Hard Drive Carrier Status LED Functions .....	45
Table 42. Hard Drive Carrier Activity LED Functions .....	45
Table 43. Backplane Input Power Connector Pin-out .....	45
Table 44. 2-Blade Compute Node Power Connector Pin-out .....	46
Table 45. 2x40 Pin Connector Pin-out for Node Bridge Board .....	46
Table 46. Front Panel Connector Pin-out .....	47
Table 47. Power Supply Control Connector Pin-out .....	48
Table 48. Front Control Button Function .....	50
Table 49. Front LED Indicator Functions .....	50
Table 50. Power LED Operation .....	51
Table 51. System Status LED Operation .....	51
Table 52. Force Integrated BMC Update Jumper .....	54
Table 53. Force Integrated BMC Update Jumper .....	54
Table 54. Force ME Update Jumper .....	55
Table 55. BIOS Password Clear Jumper .....	56
Table 56. BIOS Recovery Mode Jumper .....	56
Table 57. Reset BIOS Jumper .....	57
Table 58. Riser Card Edge Pinout .....	59
Table 59. PCI Express Slot Pinout on Riser Card .....	62
Table 60. Dedicated NIC Port LED Functionality .....	65
Table 61. Riser Card Edge Pinout .....	65
Table 62. PCI Express Slot Pinout on Riser Card .....	67
Table 63. IO Module Slot on Carrier .....	69
Table 64. POST Code Diagnostic LED Location .....	72
Table 65. POST Progress Code LED Example .....	73
Table 66. Diagnostic LED POST Code Decoder .....	73
Table 67. POST Error Message and Handling .....	76
Table 68. POST Error Beep Codes .....	79

**<This page is intentionally left blank.>**

# 1. Introduction

---

This Technical Product Specification (TPS) provides system specific information detailing the features, functionality, and high-level architecture of the Intel® Server System H2000WP family. You should also reference the *Intel® Server Board S2600WP Family Technical Product Specification* to obtain greater detail of functionality and architecture of the server board integrated in this server system.

In addition, you can obtain design-level information for specific sub-systems by ordering the *External Product Specifications (EPS)* or *External Design Specifications (EDS)* for a given sub-system. EPS and EDS documents are not publicly available. They are only made available under NDA with Intel and must be ordered through your local Intel representative. For a complete list of available documents, refer to the *Reference Documents* section at the end of this document.

The Intel® Server System H2000WP may contain design defects or errors known as errata which may cause the product to deviate from published specifications. Refer to the *Intel® Server Board S2600WP/Intel® Server System H2000WP Specification Update* for published errata.

## 1.1 Chapter Outline

This document is divided into the following chapters:

- Chapter 1 – Introduction
- Chapter 2 – Product Overview
- Chapter 3 – Power Sub-System
- Chapter 4 – Cooling Sub-System
- Chapter 5 – System Boards in the Node Tray
- Chapter 6 – Hard Disk Drive Support
- Chapter 7 – Front Panel Control and Indicators
- Chapter 8 – Configuration Jumpers
- Chapter 9 – PCI Express Riser Card and Assembly
- Appendix A – Integration and Usage Tips
- Appendix B – POST code LED Decoder
- Appendix C – Video POST Code Errors
- Glossary
- Reference Documents

## 1.2 Server Board Use Disclaimer

Intel Corporation server boards support add-in peripherals and contain a number of high-density VLSI and power delivery components that need adequate airflow to cool. Intel ensures through its own chassis development and testing that when Intel server building blocks are used together, the fully integrated system will meet the intended thermal requirements of these components. It is the responsibility of the system integrator who chooses not to use Intel developed server building blocks to consult vendor datasheets and operating parameters to determine the amount of air flow required for their specific application and environmental conditions. Intel Corporation cannot be held responsible if components fail or the server board does not operate correctly when used outside any of their published operating or non-operating limits.

## 2. Product Overview

The Intel® Server System H2000WP family includes two major SKUs: H2312WP and H2216WP, which are rack mount 2U 4-node server systems, purpose-built for high-density and lowest total cost of ownership in dense computing applications, such as HPC and IPDC. The system is integrated with four units of Intel® Server Board S2600WP, supports up to twelve 3.5" or sixteen 2.5" hot-swap SAS or SATA hard drives, with Common Redundant Power Supply (CRPS) capability .

This chapter provides a high-level overview of the system features. The following chapters provide greater detail for each major system component or feature.

**Table 1. System Feature Set**

Feature	Description
Processor	Support Intel® Xeon® Processor E5-2600 series processors. <ul style="list-style-type: none"> <li>Up to 8 GT/s Intel® QuickPath Interconnect (Intel® QPI).</li> <li>LGA 2011 Socket R</li> <li>Thermal Design Power (TDP) up to 130 Watt (6-core or 8-core), or 80W(4-core) and below.</li> </ul>
Memory	<ul style="list-style-type: none"> <li>Unbuffered DDR3 and registered DDR3 with ECC DIMMs.</li> <li>Memory DDR3 data transfer rates of 800/1066/1333/1600 MT/s.</li> <li>Load Reduced DDR3 DIMM.</li> <li>DDR3 standard I/O voltage of 1.5V(all speed) and DDR3 Low Voltage of 1.35V(1333MT/s or below)</li> </ul>
Chipset	Intel® C600 Platform Controller Hub(PCH) with support for optional Storage Upgrade Key
System Connectors /Headers	<p>External I/O connectors:</p> <ul style="list-style-type: none"> <li>DB-15 Video connectors.</li> <li>Two RJ-45 Network Interface for 10/100/1000 LAN.</li> <li>One stacked two port USB 2.0 (Port 0/1) connectors.</li> <li>One dedicated 1GbE management port on rIOM carrier (Optional).</li> <li>One InfiniBand* QDR QSFP port (Board SKU: <b>S2600WPQ</b>)</li> </ul> <p>Internal connectors/headers:</p> <ul style="list-style-type: none"> <li>Bridge Slot to extend board I/O <ul style="list-style-type: none"> <li>SCU0 (Four SAS 3Gb/s ports) to backplane</li> <li>Front control panel signals</li> <li>One SATA(Port 0) 6Gb/s port for DOM</li> </ul> </li> <li>One Type-A USB 2.0 connector (USB port 2)</li> <li>One 2x7pin header for system FAN module</li> <li>One DH-10 serial Port A connector</li> <li>One SATA 6Gb/s (Port 1)</li> <li>One 2x4 pin header for Intel® RMM4 Lite</li> <li>One 1x4 pin header for Storage Upgrade Key</li> </ul>
System Fan Support	Three sets of dual rotor fan for each node.
Add-in Adapter Support	<p>Four PCIe Gen III x16 riser slots:</p> <ul style="list-style-type: none"> <li>Riser slot 1 support PCIe Gen III x16 Riser with LP PCIe add-in card</li> <li>Riser slot 2 supports PCIe Gen III x8 Riser (Intel® rIOM)</li> <li>Riser slot 3 and slot 4 cannot be used with bridge board covered</li> </ul> <p>One Bridge Slot for board I/O expansion.</p>
On-board Video	<p>On-board Server Engines* LLC Pilot III Controller</p> <ul style="list-style-type: none"> <li>Integrated 2D Video Controller</li> </ul>

Feature	Description
	<ul style="list-style-type: none"> <li>128 MB DDR3 Memory</li> </ul>
Hard Disk Drive Supported	12x 3.5-inch SATA/SAS HDD bays (SKU: <b>H2312WP</b> ) 16x 2.5-inch SATA/SAS HDD bays (SKU: <b>H2216WP</b> )
RAID Support	<ul style="list-style-type: none"> <li>Intel RSTe SW RAID 0/1/10/5 for SATA mode</li> <li>LSI SW RAID 0/1/10/5 for SAS/SATA mode</li> </ul>
LAN	For each node <ul style="list-style-type: none"> <li>One Gigabit Ethernet device i350 connect to PCI-E x4 interfaces on the PCH, providing 2 GbE ports for each node.</li> <li>One QSFP port from Mellanox* ConnectX3 to support QDR Infiniband* based on board SKU.</li> <li>One dedicated 1GbE management port with RMM4 Lite and rIOM carrier installed</li> </ul>
System Power	1200w AC Common Redundant Power Supply (CRPS), 80 plus Platinum with PFC, supporting CRPS configuration. Chassis SKU: <b>H2312WPJR, H2216WPJR</b> 1600w AC Common Redundant Power Supply (CRPS), 80 plus Platinum with PFC, supporting CRPS configuration. Chassis SKU: <b>H2312WPKR, H2216WPKR</b>
Server Management	<ul style="list-style-type: none"> <li>Onboard ServerEngines* LLC Pilot III* Controller</li> <li>Support for Intel® Remote Management Module 4 Lite solutions.</li> <li>Intel® Light-Guided Diagnostics on field replaceable units.</li> <li>Support for Intel® System Management Software.</li> <li>Support for Intel® Intelligent Power Node Manager (Need PMBus-compliant power supply).</li> </ul>

**Table 2. System SKU matrix**

Board SKU vs Chassis	3.5" HDD with 1200W CRPS	2.5" HDD with 1200W CRPS	3.5" HDD with 1600W CRPS	2.5" HDD with 1600W CRPS
S2600WP	H2312WPJR	H2216WPJR	H2312WPKR	H2216WPKR
S2600WPQ	H2312WPQJR	H2216WPQJR	H2312WPQKR	H2216WPQKR

The Intel® Server System H2000WP family are supporting all Intel® Xeon® processor E5-2600 series with TDP 130W (8-core, 6-core), or 80W (4-core) and below. You can find a full list of supported processors at the Intel Support Website:

[http://www.intel.com/p/en\\_US/support/highlights/server/H2000WP](http://www.intel.com/p/en_US/support/highlights/server/H2000WP).

## 2.1 System Views

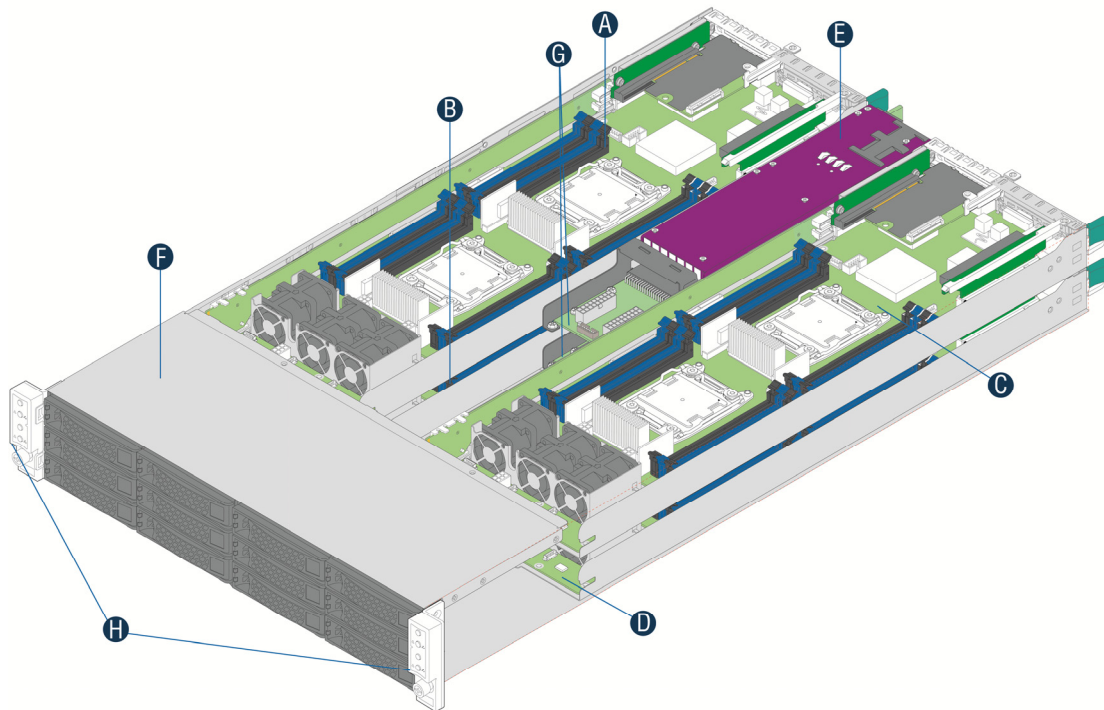

AF004861

<b>A</b>	Compute Node 3 Tray (upper left)	<b>E</b>	Common Redundant Power Supply
<b>B</b>	Compute Node 1 Tray (lower left)	<b>F</b>	HDD bays with Hot Swap Backplane
<b>C</b>	Compute Node 4 Tray (upper right)	<b>G</b>	Upper and Lower Power Distribution Boards
<b>D</b>	Compute Node 2 Tray (lower right)	<b>H</b>	Front Control Panel

**Figure 1. System Overview (Air Duct is removed)**

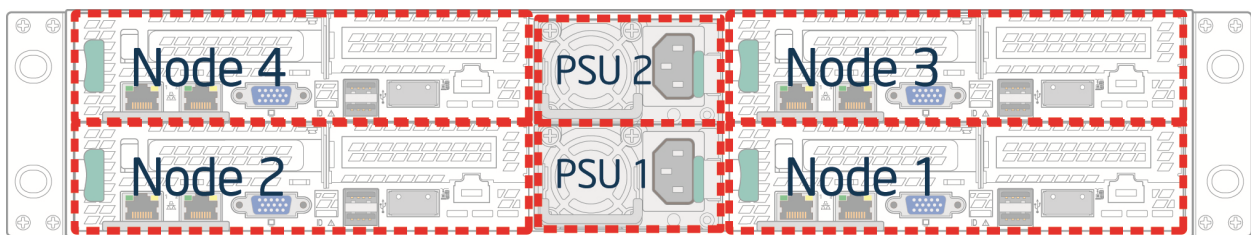

AF004513

**Figure 2. Compute Node Scheme (Rear View)**

## 2.2 System Dimensions

**Table 3. Chassis Dimension (SKU: H2312WPGR)**

Height	87.9mm	3.46"
Width	438mm	17.24"
Depth	771mm	30.35"

Weight		<b>Kg.</b>	<b>Lbs.</b>
	Chassis – basic configured (Two PSU, Zero drives)	30	66.14
	Chassis – fully configured (Two PSU, 12 drives)	38	83.78

**Table 4. Chassis Dimension (SKU: H2216WPGR)**

Height	87.9mm	3.46"
Width	438mm	17.24"
Depth	733mm	28.86"
Weight		<b>Kg.</b>
	Chassis – basic configured (2 PSU, 0 drives)	29
	Chassis – fully configured (2 PSU, 16 drives)	32
		<b>Lbs.</b>
		63.93
		70.55

### 2.3 Hard Drive and Peripheral Bays

	Intel® Server System H2312WP	Intel® Server System H2216WP
Slim-line SATA Optical Drive	Not Supported	Not Supported
Internal USB Floppy Drive	Not Supported	Not Supported
SATA/SAS Hard Disk Drives (3.5")	Up to Twelve	Not Supported
SATA/SAS Hard Disk Drives (2.5")	Not Supported	Up to Sixteen
SATA DOM	Support	Support

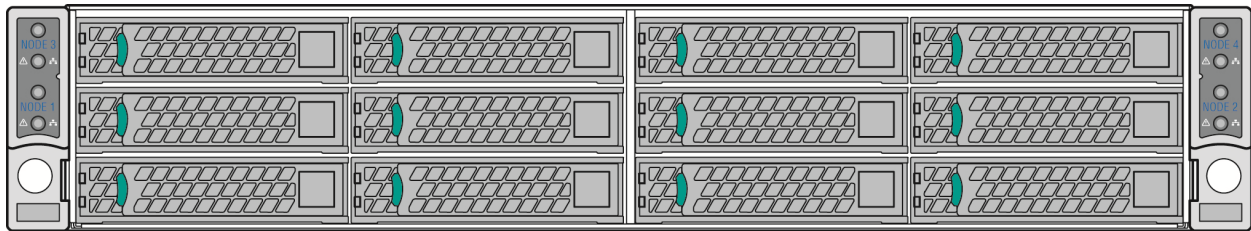

AF004635

**Figure 3. Intel® Server System H2312WP Drive Bay Overview**

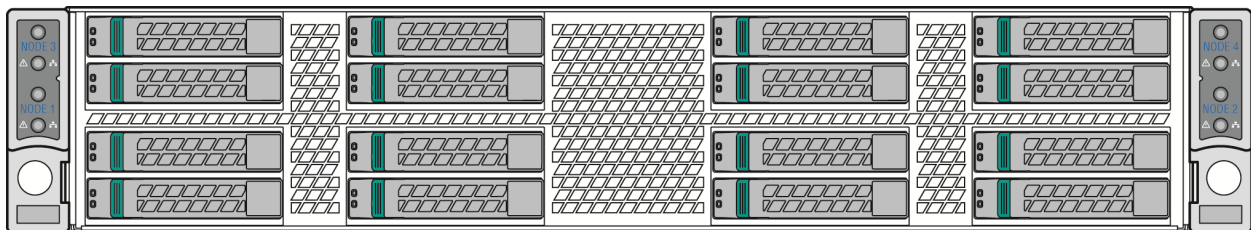

AF004637

**Figure 4. Intel® Server System H2216WP Drive Bay Overview**

### 2.4 Server Board Overview

The chassis is mechanically and functionally designed to support half-width server board, including Intel® Server Board S2600WP. The following sections provide an overview of the server board feature sets.



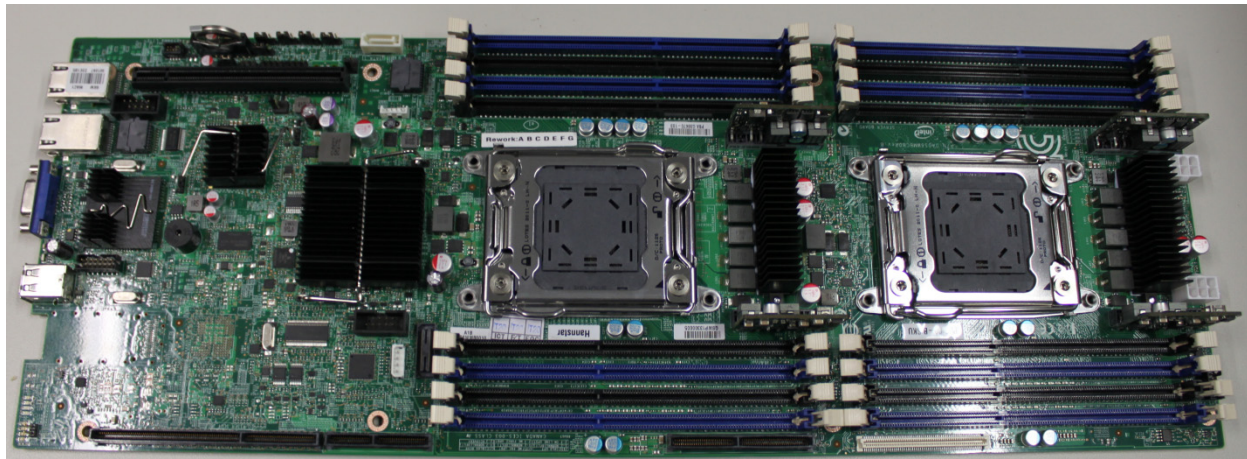

**Figure 5. Intel® Server Board S2600WPQ**

The following figure shows the layout of the server board. Each connector and major component is identified by a number or letter, and a description is given below the figure.

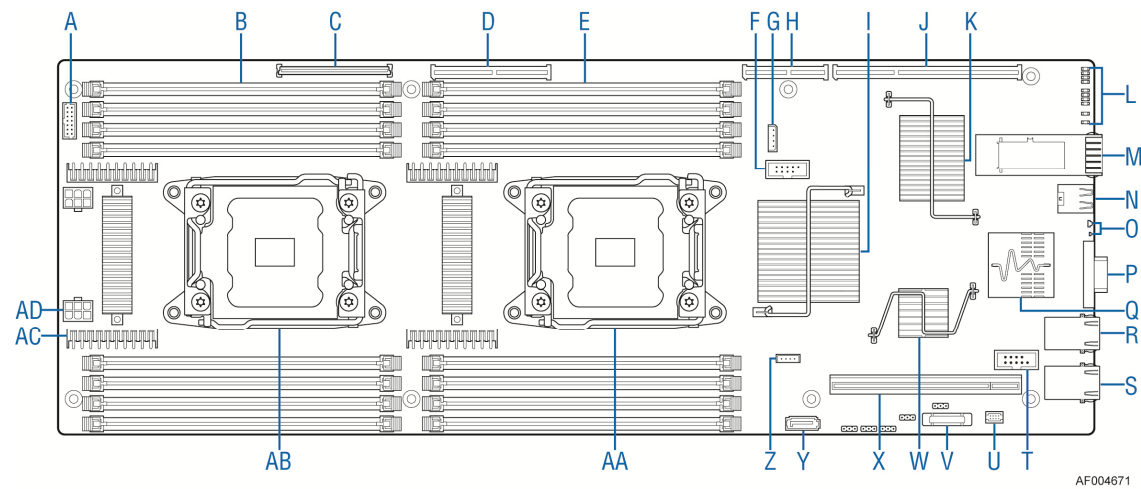

AF004671

	Description		Description		Description		Description
<b>A</b>	2x7 fan control connector	<b>I</b>	PCH C600-A	<b>Q</b>	Dual port 1GbE NIC chip	<b>Y</b>	SATA port 1
<b>B</b>	CPU2 DIMM slots (8 total)	<b>J</b>	Riser Slot 2 (PCIe Gen3x16)	<b>R</b>	NIC port 2	<b>Z</b>	Storage Upgrade key
<b>C</b>	Riser Slot 4 (PCIe Gen3x16)	<b>K</b>	Infiniband QDR	<b>S</b>	NIC Port 1	<b>AA</b>	CPU 1
<b>D</b>	Riser Slot 3 (PCIe Gen3x16)	<b>L</b>	InfiniBand status and Diagnostic LED	<b>T</b>	Serial Port A	<b>AB</b>	CPU 2
<b>E</b>	CPU1 DIMM slots (8 total)	<b>M</b>	QSFP	<b>U</b>	RMM4 lite	<b>AC</b>	VRS (4 total)
<b>F</b>	2x5 USB	<b>N</b>	USB x2	<b>V</b>	CMOS battery	<b>AD</b>	2x3 PWR connector (2 total)
<b>G</b>	IPMB connector	<b>O</b>	Status and ID LED	<b>W</b>	Integrated BMC		

	Description		Description		Description		Description
<b>H</b>	Bridge board connector	<b>P</b>	VGA out	<b>X</b>	Riser Slot 1 (PCIe Gen3x16)		

**Figure 6. Intel® Server Board S2600WP Components**

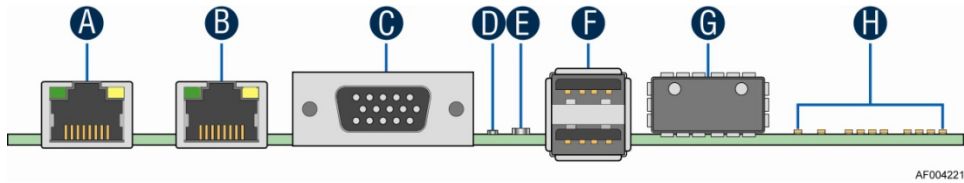

	Description		Description
<b>A</b>	NIC port 1 (RJ45)	<b>E</b>	Status LED
<b>B</b>	NIC port 2 (RJ45)	<b>F</b>	Dual port USB connector
<b>C</b>	DB15 video out	<b>G</b>	QSFP Connector
<b>D</b>	ID LED	<b>H</b>	QSFP status and Diagnostic LED

**Figure 7. Back Panel Feature Overview**

**Note:** The Intel® Server System H2312WP and H2216WP requires the use of shielded LAN cable to comply with Emission/Immunity regulatory requirements. Use of non shield cables **may result in product non-compliance**.

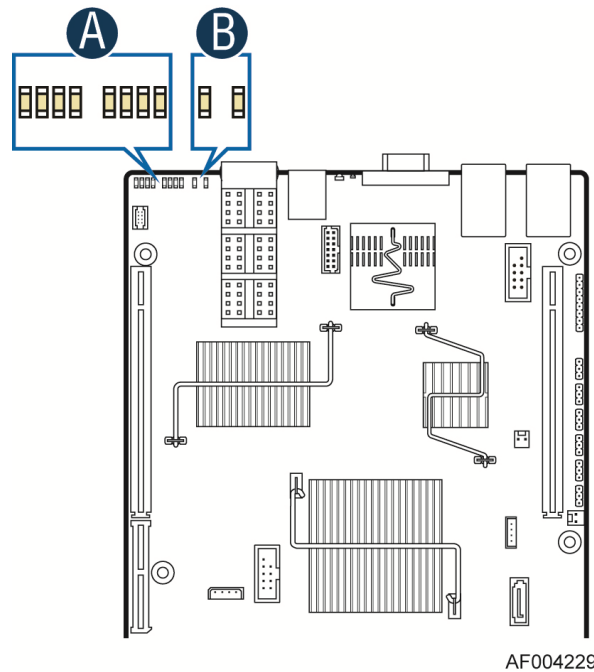

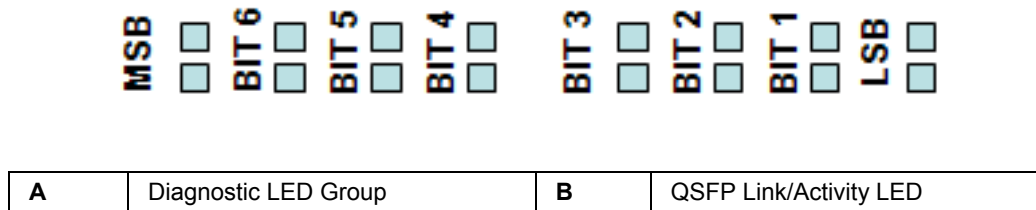

Figure 8. Light-Guided Diagnostic LED Locations

## 2.5 Front Bezel Support

Intel® Server System H2000WP family provides front panel bezel. The bezel provides protection to system HDD bays with a lock to chassis. The front view of the bezel is as below.

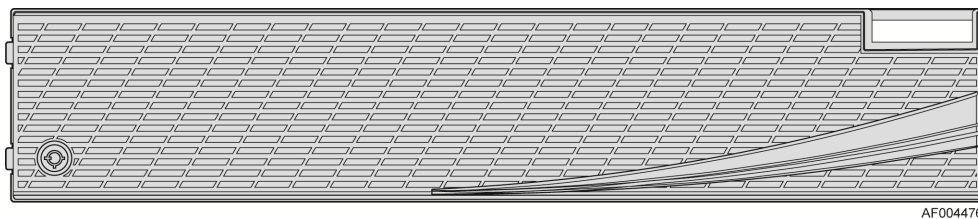

Figure 9. System Bezel Front View

## 2.6 Rack and Cabinet Mounting Options

The chassis was designed to support 19 inches wide by up to 30 inches deep server cabinets. The system bundles with the following Intel rack mount option.

A basic slide rail kit (Product order code – **AXXELVRAIL**) is designed to mount the chassis into a standard (19 inches by up to 30 inches deep) EIA-310D compatible server cabinet.

## 3. Power Sub-System

The system supports AC 1+1 hot swap power supply module and two power distribution board which can support 2U rack high density server system. Two different power supply units are supported: 1200W and 1600W. The single power supply module has Platinum level energy efficiency, demonstrating climate saver with silver rating.

### 3.1 Mechanical Overview

The power supply module has a simple retention mechanism to retain the module self once it is inserted. This mechanism shall withstand the specified mechanical shock and vibration requirements. The power distribution board will be fixed in the chassis with screws. This specification defines a 1+1 hot swap redundancy power supply that supports 2U server system. Using existing power supply module provided by vendor with updated PMBus\* and custom-made power connector board to support four nodes of Intel® server board S2600WP. The power supply shall have two outputs: 12V and 12VSB. The input shall be auto ranging and power factor corrected. The PMBus\* features included in this specification are requirements for AC silver rated box power supply for use in server systems based on Intel® Server System H2000WP Family. This specification is based on the *PMBus\* Specifications* part I and II, revision 1.1.

#### 3.1.1 AC Power Supply Unit Dimension Overview

The casing dimension is W 73.5mm x L 265.0mm x H 39/40mm. The power supply contains a single 40mm fan. The power supply has a card edge output that interfaces with a 2x25 card edge connector in the system. The AC plugs directly into the external face of the power supply.

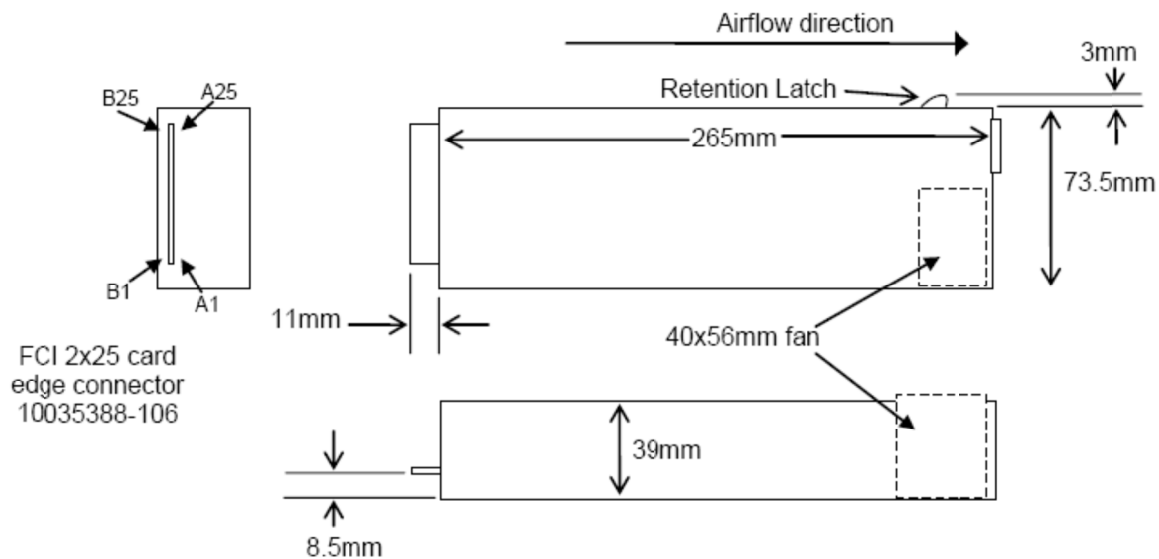

Figure 10. AC Power Supply Unit Dimension Overview

#### 3.1.2 AC input connector

The power supply has an internal IEC320 C14 power inlet. The inlet is rated for a minimum of 10A at 250VAC.

### 3.1.3 AC Power Cord Specification Requirements

The AC power cord used must meet the following specification requirements:

**Table 5. AC power cord specification**

Cable Type	SJT
Wire Size	16 AWG
Temperature Rating	105° C
Amperage Rating	13A
Cable Type	SJT

### 3.1.4 Power Supply Unit DC Output Connector

The DC output connector pin-out is defined as follows:

**Table 6. DC Output Power Connector**

PSU Output Connector			
A1	GND	B1	GND
A2	GND	B2	GND
A3	GND	B3	GND
A4	GND	B4	GND
A5	GND	B5	GND
A6	GND	B6	GND
A7	GND	B7	GND
A8	GND	B8	GND
A9	GND	B9	GND
A10	+12V	B10	+12V
A11	+12V	B11	+12V
A12	+12V	B12	+12V
A13	+12V	B13	+12V
A14	+12V	B14	+12V
A15	+12V	B15	+12V
A16	+12V	B16	+12V
A17	+12V	B17	+12V
A18	+12V	B18	+12V
A19	PMBus SDA*	B19	A0* (SMBus address)
A20	PMBus SCL*	B20	A1* (SMBus address)
A21	PSON	B21	12V STBY
A22	SMBAAlert#	B22	Cold Redundancy Bus*
A23	Return Sense	B23	12V load share bus
A24	+12V Remote Sense	B24	No Connect
A25	PWOK	B25	CRPS Compatibility Check pin*

\*: Refer to the spec of CRPS Common Requirements specification.

### 3.1.5 Handle Retention

The power supply has a handle to assist extraction. The module is able to be inserted and extracted without the assistance of tools. The power supply also has a latch which retains the power supply into the system and prevents the power supply from being inserted or extracted from the system when the AC power cord is pulled into the power supply.

The handle protects the operator from any burn hazard through the use of industrial designed plastic handle or equivalent material.

### 3.1.6 LED Marking and Identification

The power supply is using a bi-color LED: Amber and Green for status indication. Below are table showing the LED states for each power supply operating state.

**Table 7. Power Supply Status LED**

Power Supply Condition	LED State
Output ON and OK	Solid GREEN
No AC power to all power supplies	OFF
AC present/Only 12VSB on (PS off) or PS in Cold redundant state	1Hz Blink GREEN
AC cord unplugged or AC power lost; with a second power supply in parallel still with AC input power.	Solid AMBER
Power supply warning events where the power supply continues to operate; high temp, high power, high current, slow fan.	1Hz Blink Amber
Power supply critical event causing a shutdown; failure, OCP, OVP, Fan Fail	Solid AMBER
Power supply FW updating	2Hz Blink GREEN

### 3.1.7 Power Cage with Power Distribution Board

The power cage is at the middle of the chassis, consists of two Power Distribution Boards (PDB) to support Common Redundant Power Supplies (CRPS).

Below is the power system overview:

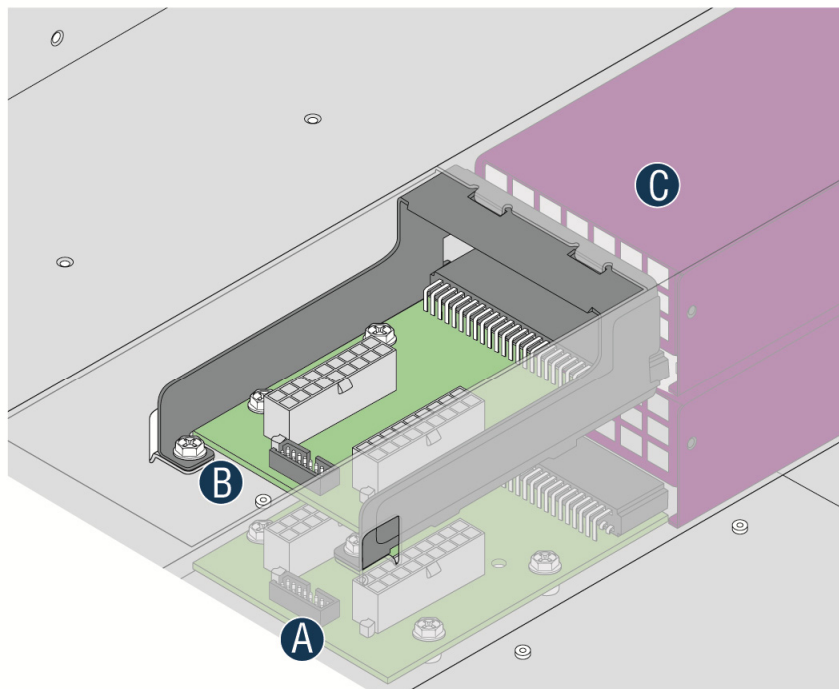

AF004696

<b>A</b>	Power Distribution Board 1
<b>B</b>	Power Distribution Board 2
<b>C</b>	Power Supply Unit #2(upper) and #1(lower)

**Figure 11. Power Cage Overview**

### 3.1.8 Power Cage Output Pin Assignment

The power cage provides +12V and +12V<sub>STB</sub> output to the system. Each PDB has two 2x9 power output cable to system backplane, together with one 2x8 signal control cable for power management. Refer to below table for PDB pin assignment.

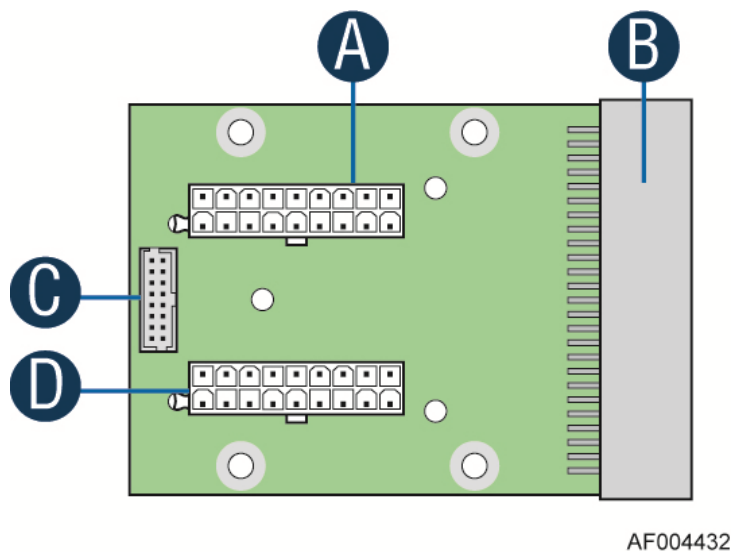

<b>A</b>	Main Power Output Connector P1
<b>B</b>	Power Supply Unit Connector
<b>C</b>	Control Signal Connector
<b>D</b>	Main Power Output Connector P2

**Figure 12. Power distribution board**

**Table 8. Pin assignment of power output connector**

Pin	Description	Pin	Description
1	GND	2	+12V
3	GND	4	+12V
5	GND	6	+12V
7	GND	8	+12V
9	GND	10	+12V
11	GND	12	+12V
13	GND	14	+12V
15	GND	16	+12V
17	GND	18	+12V

**Table 9. Pin assignment of control signal connector**

Pin	Description	Pin	Description
1	PMBus SDA	2	A0 (SMBus Address)



Pin	Description	Pin	Description
3	PMBus SCL	4	A1 (SMBus Address)
5	PSO#	6	12V Load Share Bus
7	SMBAlert#	8	Cold Redundancy Bus
9	Return Sense	10	PWOK
11	+12V Remote Sense	12	Compatibility Bus
13	Reserved	14	+12VSB
15	+12VSB	16	Key Pin (removed)

## 3.2 AC Input Specification

### 3.2.1 Input Voltage And Frequency

The power supply must operate within all specified limits over the following input voltage range. Harmonic distortion of up to 10% THD must not cause the power supply to go out of specific limits. The power supply shall be capable of start-up (power-on) with full rated power load, at line voltage as low as 90VAC.

**Table 10. AC input rating.**

Parameter	Min	Rated	Max	Start up VAC	Power Off VAC
110V <sub>AC</sub>	90 V <sub>rms</sub>	100-127 V <sub>rms</sub>	140 V <sub>rms</sub>	85 V <sub>AC</sub> ± 4V <sub>AC</sub>	70V <sub>AC</sub> ±5V <sub>AC</sub>
220V <sub>AC</sub>	180 V <sub>rms</sub>	200-240 V <sub>rms</sub>	264 V <sub>rms</sub>		
Frequency	47 Hz	50/60 Hz	63 Hz		

**Note:**

1. Maximum input current at low input voltage range shall be measured at 90VAC, at max load.
2. Maximum input current at high input voltage range shall be measured at 180VAC, at max load.
3. This requirement is not to be used for determining agency input current markings.

### 3.2.2 AC Input Power Factor

The power supply must meet the power factor requirements stated in the Energy Star® Program Requirements for Computer Servers. These requirements are stated below.

**Table 11. Typical power factor**

Output power	10% load	20% load	50% load	100% load
Power factor	> 0.80	> 0.90	> 0.90	> 0.95

**Note:** Tested at 230Vac, 50Hz and 60Hz and 115VAC, 60Hz. Tested according to Generalized Internal Power Supply Efficiency Testing Protocol Rev 6.4.3. This is posted at <http://efficientpowersupplies.epri.com/methods.asp>.

### 3.2.3 Efficiency

The following table provides the required minimum efficiency level at various loading conditions. These are provided at three different load levels; 100%, 50%, 20%, and 10%. Output shall be

load according to the proportional loading method defined by 80 Plus in Generalized Internal Power Supply Efficiency Testing Protocol Rev 6.4.3. This is posted at:  
<http://efficientpowersupplies.epri.com/methods.asp>.

**Table 12. Platinum Efficiency Requirement**

Loading	100% of maximum	50% of maximum	20% of maximum	10% of maximum
Minimum Efficiency	91%	94%	90%	82%

The power supply must pass with enough margin to make sure in production all power supplies meet these efficiency requirements.

### 3.2.4 AC Line Fuse

The power supply shall have one line fused in the single line fuse on the line (Hot) wire of the AC input. The line fusing shall be acceptable for all safety agency requirements. The input fuse shall be a slow blow type. AC inrush current shall not cause the AC line fuse to blow under any conditions. All protection circuits in the power supply shall not cause the AC fuse to blow unless a component in the power supply has failed. This includes DC output load short conditions.

### 3.2.5 AC Line Inrush

AC line inrush current shall not exceed **65A peak**, for up to one-quarter of the AC cycle, after which, the input current should be no more than the specified maximum input current. The peak inrush current shall be less than the ratings of its critical components (including input fuse, bulk rectifiers, and surge limiting device).

The power supply must meet the inrush requirements for any rated AC voltage, during turn on at any phase of AC voltage, during a single cycle AC dropout condition as well as upon recovery after AC dropout of any duration, and over the specified temperature range ( $T_{op}$ ).

### 3.2.6 AC Line Dropout/Holdup

An AC line dropout is defined to be when the AC input drops to 0VAC at any phase of the AC line for any length of time. During an AC dropout the power supply must meet dynamic voltage regulation requirements. An AC line dropout of any duration shall not cause tripping of control signals or protection circuits. If the AC dropout lasts longer than the holdup time the power supply should recover and meet all turn on requirements. The power supply shall meet the AC dropout requirement over rated AC voltages and frequencies. A dropout of the AC line for any duration shall not cause damage to the power supply.

**Table 13. AC Power Holdup Requirement**

Loading	Holdup time
70%	10.6msec

The  $12V_{STB}$  output voltage should stay in regulation under its full load (static or dynamic) during an AC dropout of **70ms min** (=12VSB holdup time) whether the power supply is in ON or OFF state (PSON asserted or de-asserted).

### 3.2.7 AC Line Fast Transient (EFT) Specification

The power supply shall meet the *EN61000-4-5* directive and any additional requirements in *IEC1000-4-5: 1995* and the Level 3 requirements for surge-withstand capability, with the following conditions and exceptions:

- These input transients must not cause any out-of-regulation conditions, such as overshoot and undershoot, nor must it cause any nuisance trips of any of the power supply protection circuits.
- The surge-withstand test must not produce damage to the power supply.

The supply must meet surge-withstand test conditions under maximum and minimum DC-output load conditions.

### 3.2.8 Hot Plug

Power supply shall be designed to allow connection into and removal from the system without removing power to the system. During any phase of insertion, start-up, shutdown, or removal, the power supply shall not cause any other like modules in the system to deviate outside of their specifications. When AC power is applied, the auxiliary supply shall turn on providing bias power internal to the supply and the 5VSB standby output.

### 3.2.9 Susceptibility Requirements

The power supply shall meet the following electrical immunity requirements when connected to a cage with an external EMI filter, which meets the criteria, defined in the SSI document EPS Power Supply Specification. For further information on customer standards please request a copy of the customer Environmental Standards Handbook.

**Table 14. Performance Criteria**

Level	Description
A	The apparatus shall continue to operate as intended. No degradation of performance.
B	The apparatus shall continue to operate as intended. No degradation of performance beyond spec limits.
C	Temporary loss of function is allowed provided the function is self-recoverable or can be restored by the operation of the controls.

### 3.2.10 Electrostatic Discharge Susceptibility

The power supply shall comply with the limits defined in EN 55024: 1998 using the IEC 61000-4-2:1995 test standard and performance criteria B defined in Annex B of CISPR 24.

### 3.2.11 Fast Transient/Burst

The power supply shall comply with the limits defined in EN55024: 1998 using the IEC 61000-4-4:1995 test standard and performance criteria B defined in Annex B of CISPR 24.

### 3.2.12 Radiated Immunity

The power supply shall comply with the limits defined in EN55024: 1998 using the IEC 61000-4-3:1995 test standard and performance criteria A defined in Annex B of CISPR 24.

### 3.2.13 Surge Immunity

The power supply shall be tested with the system for immunity to AC Ring wave and AC Unidirectional wave, both up to 2kV, per EN 55024:1998, EN 61000-4-5:1995 and ANSI C62.45: 1992.

The pass criteria include: No unsafe operation is allowed under any condition; All power supply output voltage levels to stay within proper spec levels; No change in operating state or loss of data during and after the test profile; No component damage under any condition.

The power supply shall comply with the limits defined in EN55024: 1998 using the IEC 61000-4-5:1995 test standard and performance criteria B defined in Annex B of CISPR 24.

### 3.2.14 AC Line Transient Specification

AC line transient conditions shall be defined as “sag” and “surge” conditions. “Sag” conditions are also commonly referred to as “brownout”, these conditions will be defined as the AC line voltage dropping below nominal voltage conditions. “Surge” will be defined to refer to conditions when the AC line voltage rises above nominal voltage.

The power supply shall meet the requirements under the following AC line sag and surge conditions.

**Table 15. AC Line Sag Transient Performance**

AC Line Sag (10 sec interval between each sagging)				
Duration	Sag	Operating AC Voltage	Line Frequency	Performance Criteria.
0 to ½ AC cycle	95%	Nominal AC Voltage ranges	50/60Hz	No loss of function or performance.
> 1 AC cycle	>30%	Nominal AC Voltage ranges	50/60Hz	Loss of function acceptable, self-recoverable.

**Table 16. AC Line Surge Transient Performance**

AC Line Surge				
Duration	Surge	Operating AC Voltage	Line Frequency	Performance Criteria
Continuous	10%	Nominal AC Voltages	50/60Hz	No loss of function or performance
0 to ½ AC cycle	30%	Mid-point of nominal AC Voltages	50/60Hz	No loss of function or performance

### 3.2.15 Power recovery

The power supply shall recover automatically after an AC power failure. AC power failure is defined to be any loss of AC power that exceeds the dropout criteria.

### 3.2.16 Voltage Interruptions

The power supply shall comply with the limits defined in EN55024: 1998/A1: 2001/A2: 2003 using the IEC 61000-4-11: Second Edition: 2004-03 test standard and performance criteria C defined in Annex B of CISPR 24.

### 3.2.17 AC Line Isolation

The power supply shall meet all safety agency requirements for dielectric strength. Transformers' isolation between primary and secondary windings must comply with the 3000Vac (4242Vdc) dielectric strength criteria. If the working voltage between primary and secondary dictates a higher dielectric strength test voltage the highest test voltage should be used. In addition the insulation system must comply with reinforced insulation per safety standard IEC 950. Separation between the primary and secondary circuits, and primary to ground circuits, must comply with the IEC 950 spacing requirements.

### 3.2.18 AC Power Inlet

The AC input connector should be an *IEC 320 C-14* power inlet. This inlet is rated for 10A/250 VAC.

The AC power cord must meet the following specification requirements:

Cable Type	SJT
Wire Size	16 AWG
Temperature Rating	105° C
Amperage Rating	13 A
Voltage Rating	125 V

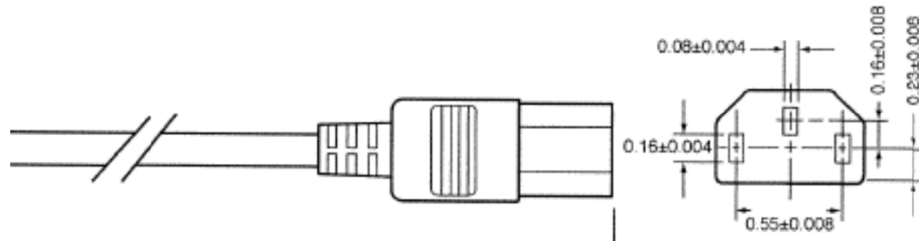

Figure 13. AC Power Cord Specification

## 3.3 DC Output Specification

### 3.3.1 Output Power/Currents

The following table defines the minimum power and current ratings. The power supply must meet both static and dynamic voltage regulation requirements for all conditions.

Table 17. Load Ratings for single power supply unit

Parameter	Min	Max		Peak <sup>2,3</sup>		Unit
		1200W	1600W	1200W	1600W	
PSU SKU		1200W	1600W	1200W	1600W	
+12V main (200-240VAC)	0.0	100	133	133	175	A
+12V main (100-127VAC)	0.0	83	83	110	110	A
+12V <sub>STB</sub>	0.0	3.0	3.5	3.5	2.4	A

**Notes:**

1. 12V<sub>STB</sub> must provide 4.0A with two power supplies in parallel. The power supply fan is allowed to run in standby mode for loads > 1.5A.
2. Peak combined power for all outputs shall not exceed 1600W (for 1200W PSU) and 2100W (for 1600W PSU)
3. Length of time peak power can be supported is based on thermal sensor and assertion of the SMBAlert# signal. Minimum peak power duration shall be 20 seconds without asserting the SMBAlert# signal.

### 3.3.2 Standby Output

The 12VSB output shall be present when an AC input greater than the power supply turn on voltage is applied.

### 3.3.3 Voltage Regulation

The power supply output voltages must stay within the following voltage limits when operating at steady state and dynamic loading conditions. These limits include the peak-peak ripple/noise. These shall be measured at the output connectors.

**Table 18. Voltage Regulation Limits**

Parameter	Min	Nom	Max	Unit	Tolerance
+12V <sub>STB</sub>	+11.40V	+12.000V	+12.60V	Vrms	±5%
+12V	+11.40V	+12.000V	+12.60V	Vrms	±5%

The combined output continuous power of all outputs shall not exceed 3200W (1600W from each power supply unit). Each output has a maximum and minimum current rating shown in below table. The power supply shall meet both static and dynamic voltage regulation requirements for the minimum dynamic loading conditions. The power supply shall meet only the static load voltage regulation requirements for the minimum static load conditions.

### 3.3.4 Dynamic Loading

The output voltages shall remain within limits specified for the step loading and capacitive loading specified in the table below. The load transient repetition rate shall be tested between 50Hz and 5kHz at duty cycles ranging from 10%-90%. The load transient repetition rate is only a test specification. The  $\Delta$  step load may occur anywhere within the MIN load to the MAX load conditions.

**Table 19 Transient Load Requirements**

Output	$\Delta$ Step Load Size	Load Slew Rate	Test capacitive Load
+12V <sub>STB</sub>	1.0A	0.25 A/ $\mu$ sec	20 $\mu$ F
+12V	60% of max load	0.25 A/ $\mu$ sec	2000 $\mu$ F

**Note:** For dynamic condition +12V min loading is 1A.

### 3.3.5 Capacitive Loading

The power supply must be stable and meet all requirements, with the following capacitive loading conditions.

**Table 20. Capacitive Loading Conditions**

Output	Min	Max	Units
+12V	500	25,000	$\mu$ F
+12V <sub>STB</sub>	20	3100	$\mu$ F

### 3.3.6 Ripple/Noise

The maximum allowed ripple/noise output of the power supply is defined in below table. This is measured over a bandwidth of 10Hz to 20MHz at the power supply output connectors. A 10 $\mu$ F tantalum capacitor in parallel with a 0.1 $\mu$ F ceramic capacitor is placed at the point of measurement.

**Table 21. Ripple and Noise**

+12V	+12V <sub>STB</sub>

120mVp-p
----------

120mVp-p
----------

### 3.3.7 Grounding

The output ground of the pins of the power supply provides the output power return path. The output connector ground pins shall be connected to the safety ground (power supply enclosure). This grounding should be well designed to ensure passing the max allowed Common Mode Noise levels.

The power supply shall be provided with a reliable protective earth ground. All secondary circuits shall be connected to protective earth ground. Resistance of the ground returns to chassis shall not exceed 1.0 mΩ. This path may be used to carry DC current.

### 3.3.8 Closed Loop Stability

The power supply shall be unconditionally stable under all line/load/transient load conditions including capacitive load ranges specified in Section 4.6. A minimum of: **45 degrees phase margin** and **-10dB-gain margin** is required. The power supply manufacturer shall provide proof of the unit's closed-loop stability with local sensing through the submission of Bode plots. Closed-loop stability must be ensured at the maximum and minimum loads as applicable.

### 3.3.9 Residual Voltage Immunity in Standby Mode

The power supply should be immune to any residual voltage placed on its outputs (Typically a leakage voltage through the system from standby output) up to 500mV. There shall be no additional heat generated, nor stressing of any internal components with this voltage applied to any individual or all outputs simultaneously. It also should not trip the protection circuits during turn on.

The residual voltage at the power supply outputs for no load condition shall not exceed 100mV when AC voltage is applied and the PSON# signal is de-asserted.

### 3.3.10 Common Mode Noise

The Common Mode noise on any output shall not exceed **350mVp-p** over the frequency band of 10Hz to 20MHz.

1. The measurement shall be made across a 100Ω resistor between each of DC outputs, including ground at the DC power connector and chassis ground (power subsystem enclosure).
2. The test set-up shall use a FET probe such as Tektronix model P6046 or equivalent.

### 3.3.11 Soft Starting

The Power Supply shall contain control circuit which provides monotonic soft start for its outputs without overstress of the AC line or any power supply components at any specified AC line or load conditions.

### 3.3.12 Zero Load Stability Requirement

When the power subsystem operates in a no load condition, it does not need to meet the output regulation specification, but it must operate without any tripping of over-voltage or other fault circuitry. When the power subsystem is subsequently loaded, it must begin to regulate and source current without fault.

### 3.3.13 Hot Swap Requirement

Hot swapping a power supply is the process of inserting and extracting a power supply from an operating power system. During this process the output voltages shall remain within the limits with the capacitive load specified. The hot swap test must be conducted when the system is operating under static, dynamic, and zero loading conditions. The power supply shall use a latching mechanism to prevent insertion and extraction of the power supply when the AC power cord is inserted into the power supply.

### 3.3.14 Forced Load Sharing

The +12V output will have active load sharing. The output will share within 10% at full load. The failure of a power supply should not affect the load sharing or output voltages of the other supplies still operating. The supplies must be able to load share in parallel and operate in a hot-swap/redundant **1+1** configurations. The 12VSB output is not required to actively share current between power supplies (passive sharing). The 12VSB output of the power supplies are connected together in the system so that a failure or hot swap of a redundant power supply does not cause these outputs to go out of regulation in the system.

### 3.3.15 Timing Requirement

These are the timing requirements for the power supply operation. The output voltages must rise from 10% to within regulation limits ( $T_{\text{vout\_rise}}$ ) within 5 to 70ms. For 12VSB, it is allowed to rise from 1.0 to 25ms. **All outputs must rise monotonically.** Table below shows the timing requirements for the power supply being turned on and off via the AC input, with PSON held low and the PSON signal, with the AC input applied.

**Table 22. Timing Requirement**

Item	Description	MIN	MAX	UNITS
$T_{\text{vout\_rise}}$	Output voltage rise time	5.0 *	70 *	ms
$T_{\text{sb\_on\_delay}}$	Delay from AC being applied to 12VSB being within regulation.		1500	ms
$T_{\text{ac\_on\_delay}}$	Delay from AC being applied to all output voltages being within regulation.		3000	ms
$T_{\text{vout\_holdup}}$	Time 12VI output voltage stay within regulation after loss of AC.	13		ms
$T_{\text{pwok\_holdup}}$	Delay from loss of AC to de-assertion of PWOK	10.6		ms
$T_{\text{pson\_on\_delay}}$	Delay from PSON# active to output voltages within regulation limits.	5	400	ms
$T_{\text{pson\_pwok}}$	Delay from PSON# deactivate to PWOK being de-asserted.		<b>5</b>	ms
$T_{\text{pwok\_on}}$	Delay from output voltages within regulation limits to PWOK asserted at turn on.	100	500	ms
$T_{\text{pwok\_off}}$	Delay from PWOK de-asserted to output voltages dropping out of regulation limits.	1		ms
$T_{\text{pwok\_low}}$	Duration of PWOK being in the de-asserted state during an off/on cycle using AC or the PSON signal.	100		ms
$T_{\text{sb\_vout}}$	Delay from 12VSB being in regulation to O/Ps being in regulation at AC turn on.	50	1000	ms
$T_{\text{12VSB\_holdup}}$	Time the 12VSB output voltage stays within regulation after loss of AC.	70		ms

**Note:** \* The 12V<sub>STB</sub> output voltage rise time shall be from 1.0ms to 25ms.



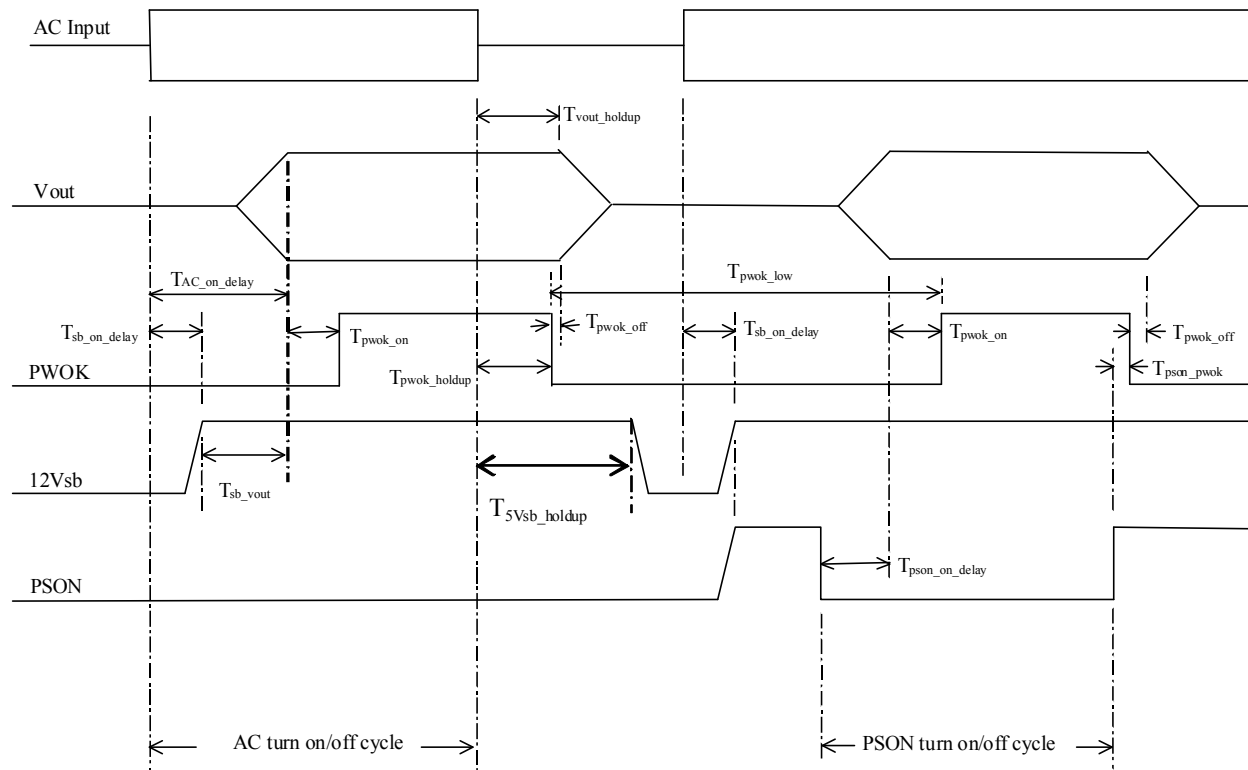

**Figure 14. Turn On/Off Timing (Power Supply Signals)**

### 3.4 Power Supply Cold Redundancy Support

Power supplies that support cold redundancy can be enabled to go into a low-power state (that is, cold redundant state) in order to provide increased power usage efficiency when system loads are such that both power supplies are not needed. When the power subsystem is in Cold Redundant mode, only the needed power supply to support the best power delivery efficiency is ON. Any additional power supplies; including the redundant power supply, is in Cold Standby state.

Each power supply has an additional signal that is dedicated to supporting Cold Redundancy; CR\_BUS. This signal is a common bus between all power supplies in the system. CR\_BUS is asserted when there is a fault in any power supply OR the power supplies output voltage falls below the  $V_{fault}$  threshold. Asserting the CR\_BUS signal causes all power supplies in Cold Standby state to power ON.

Enabling power supplies to maintain best efficiency is achieved by looking at the Load Share bus voltage and comparing it to a programmed voltage level via a PMBus command.

Whenever there is no active power supply on the Cold Redundancy bus driving a HIGH level on the bus all power supplies are ON no matter their defined Cold Redundant roll (active or Cold Standby). This guarantees that incorrect programming of the Cold Redundancy states of the power supply will never cause the power subsystem to shut down or become over loaded. The default state of the power subsystem is all power supplies ON. There needs to be at least one power supply in Cold Redundant Active state or Standard Redundant state to allow the Cold Standby state power supplies to go into Cold Standby state.

### 3.4.1 1200W CRPS Cold Redundancy

If the output power is less than 480W (40%), the Cold redundant function will be enable. Thus you will see one PSU working normal. The second PSU will be CR mode. The Power Supply LED is green blinking.

**Table 23. 1200W CRPS Cold Redundancy Threshold.**

	Enable (V)	percent	power (W)	Disable (V)	percent	power (W)
Cold Standby 1 (02h)	3.2	40.00%	480(±5%)	1.44	18.00%	432(±5%)

### 3.4.2 1600W CRPS Cold Redundancy

If the output power is less than 640W (40%), the Cold redundant function will be enable. Thus you will see one PSU working normal. The second PSU will be CR mode. The Power Supply LED is green blinking.

**Table 24. 1600W CRPS Cold Redundancy Threshold.**

	Enable (V)	percent	power (W)	Disable (V)	percent	power (W)
Cold Standby 1 (02h)	3.2	40.00%	640(±5%)	1.44	18.00%	576(±5%)

## 3.5 Control And Indicator Functions

The following sections define the input and output signals from the power supply.

Signals that can be defined as low true use the following convention: **Signal<sup>#</sup> = low true**

### 3.5.1 PSON# Input Signal

The PSON<sup>#</sup> signal is required to remotely turn on/off the power supply. PSON<sup>#</sup> is an active low signal that turns on the +12V power rail. When this signal is not pulled low by the system, or left open, the outputs (except the +12VSB) turn off. This signal is pulled to a standby voltage by a pull-up resistor internal to the power supply. Refer to *below table* for the timing diagram.

**Table 25. PSON# Signal Characteristics.**

Signal Type	Accepts an open collector/drain input from the system. Pull-up to VSB located in power supply.	
PSON <sup>#</sup> = Low	ON	
PSON <sup>#</sup> = High or Open	OFF	
	MIN	MAX
Logic level low (power supply ON)	0V	1.0V
Logic level high (power supply OFF)	2.0V	3.46V
Source current, Vpson = low		4mA
Power up delay: T <sub>pson_on_delay</sub>	5msec	400msec
PWOK delay: T <sub>pson_pwok</sub>		50msec

### 3.5.2 PWOK(power good) Output Signal

PWOK is a power OK signal and will be pulled HIGH by the power supply to indicate that all the outputs are within the regulation limits of the power supply. When any output voltage falls below regulation limits or when AC power has been removed for a time sufficiently long so that power supply operation is no longer guaranteed, PWOK will be de-asserted to a LOW state. See the table below for a representation of the timing characteristics of PWOK. The start of the PWOK delay time shall be inhibited as long as any power supply output is in current limit.

**Table 26. PWOK Signal Characteristics**

Signal Type		
PWOK = High	Power OK	
PWOK = Low	Power Not OK	
	MIN	MAX
Logic level low voltage, Isink=400uA	0V	0.4V
Logic level high voltage, Isource=200uA	2.4V	3.46V
Sink current, PWOK = low		400uA
Source current, PWOK = high		2mA
PWOK delay: Tpwok_on	100ms	1000ms
PWOK rise and fall time		100µsec
Power down delay: T pwok_off	1ms	200msec

### 3.5.3 SMBAlert# Signal

This signal indicates that the power supply is experiencing a problem that the user should investigate. This shall be asserted due to Critical events or Warning events. The signal shall activate in the case of critical component temperature reached a warning threshold, general failure, over-current, over-voltage, under-voltage, failed fan. This signal may also indicate the power supply is reaching its end of life or is operating in an environment exceeding the specified limits.

This signal is to be asserted in parallel with LED turning solid Amber or blink Amber.

**Table 27. SMBAlert# Signal Characteristics**

Signal Type (Active Low)	Open collector/drain output from power supply. Pull-up to VSB located in system.	
Alert# = High	OK	
Alert# = Low	Power Alert to system	
	MIN	MAX
Logic level low voltage, Isink=4 mA	0 V	0.4 V
Logic level high voltage, Isink=50 µA		3.46 V
Sink current, Alert# = low		4 mA
Sink current, Alert# = high		50 µA
Alert# rise and fall time		100 µs

## 3.6 Protection circuits

Protection circuits inside the power supply shall cause only the power supply's main outputs to shut down. If the power supply latches off due to a protection circuit tripping, an AC cycle OFF for 15sec and a PSON<sup>#</sup> cycle HIGH for 1sec shall be able to reset the power supply.

### 3.6.1 Current Limit (OCP)

The power supply shall have current limit to prevent the outputs from exceeding the values shown in table below. If the current limits are exceeded the power supply shall shutdown and latch off. The latch will be cleared by toggling the PSON<sup>#</sup> signal or by an AC power interruption. The power supply shall not be damaged from repeated power cycling in this condition. 12VSB will be auto-recovered after removing OCP limit.

**Table 28. Over Current Protection**

Output VOLTAGE PSU SKU	Input voltage range	OVER CURRENT LIMITS	
		1200W	1600W
+12V	90 – 264VAC	140A min; 170A max	180A min; 200A max
+12V <sub>STB</sub>	90 – 264VAC	2.5A min; 3A max	2.5A min; 3A max

### 3.6.2 Over Voltage Protection (OVP)

The power supply over voltage protection shall be locally sensed. The power supply shall shutdown and latch off after an over voltage condition occurs. This latch shall be cleared by toggling the PSON<sup>#</sup> signal or by an AC power interruption. The values are measured at the output of the power supply's connectors. The voltage shall never exceed the maximum levels when measured at the power connectors of the power supply connector during any single point of fail. The voltage shall never trip any lower than the minimum levels when measured at the power connector. 12VSB will be auto-recovered after removing OVP limit.

**Table 29. Over Voltage Protection (OVP) Limits**

Output Voltage	MIN (V)	MAX (V)
+12V	13.3	14.5
+12VSB	13.3	14.5

### 3.6.3 Over Thermal protection

The power supply will be protected against over temperature conditions caused by loss of fan cooling or excessive ambient temperature. In an OTP condition the PSU will shut down. When the power supply temperature drops to within specified limits, the power supply shall restore power automatically, while the 12VSB remains always on. The OTP circuit must have built in margin such that the power supply will not oscillate on and off due to temperature recovering condition. The OTP trip level shall have a minimum of 4°C of ambient temperature margin.

### 3.7 PMBus\*

The PMBus\* features are requirements for power supply unit for use in server systems. This specification is based on the PMBus\* specifications part I and II, revision 1.1. The power supply device address locations are shown below:

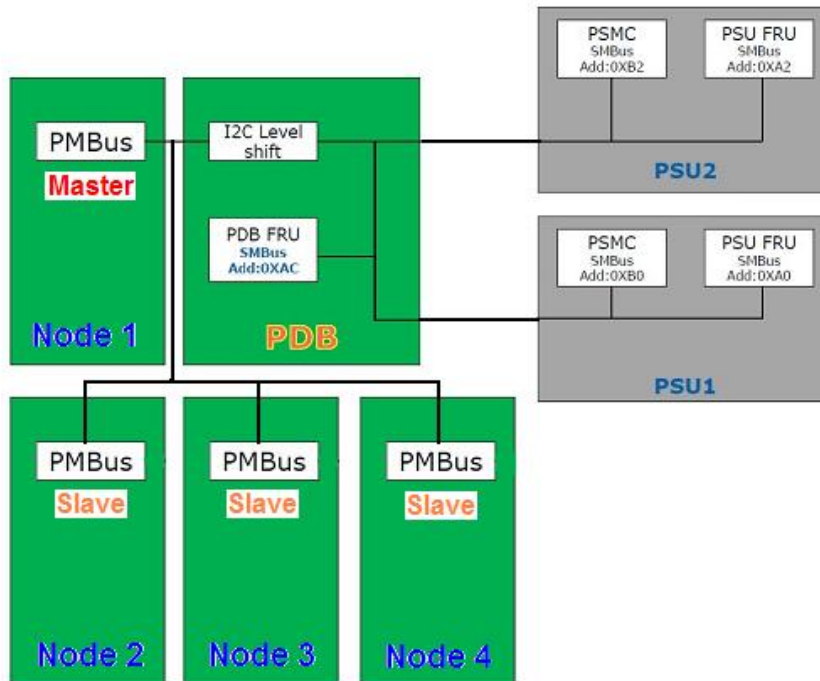

**Figure 15. Power Supply Device Address**

The PMBus from PDB is connected to BMC of all four nodes. Only one board BMC is assigned to be the master BMC and communicate with PSU as single point. Other board BMCs are getting PSU data from the master BMC. In case the master BMC is down, one of the slave board BMC will be promoted automatically as master BMC and maintain the communication.

#### 3.7.1 PSU Address Lines A0

Address pins A0 is used by end use system to allocate unit address to a power supply in particular slot position.

For redundant systems there are two signals to set the address location of the power supply once it is installed in the system; Address0 and Address1. For non-redundant systems the power supply device address locations should align with the Address0/Address1 location of 0/0.

**Table 30. PSU addressing**

PDB addressing Address0	0	1
Power supply PMBus™ device	B0h	B2h

### 3.7.2 Accuracy

The sensor commands shall meet the following accuracy requirements. The accuracies shall be met over the specified ambient temperature and the full range of rated input voltage.

**Table 31. PMBus Accuracy**

Output Loading	10% - 20%	> 20% - 50%	> 50% - 100%
READ_PIN and READ_EIN	See graphs below		
READ_FAN	+/-500 RPM		
READ_IOUT	+/-5%	+/-2%	+/-2%
READ_TEMPERATURE	+/- 3°C		

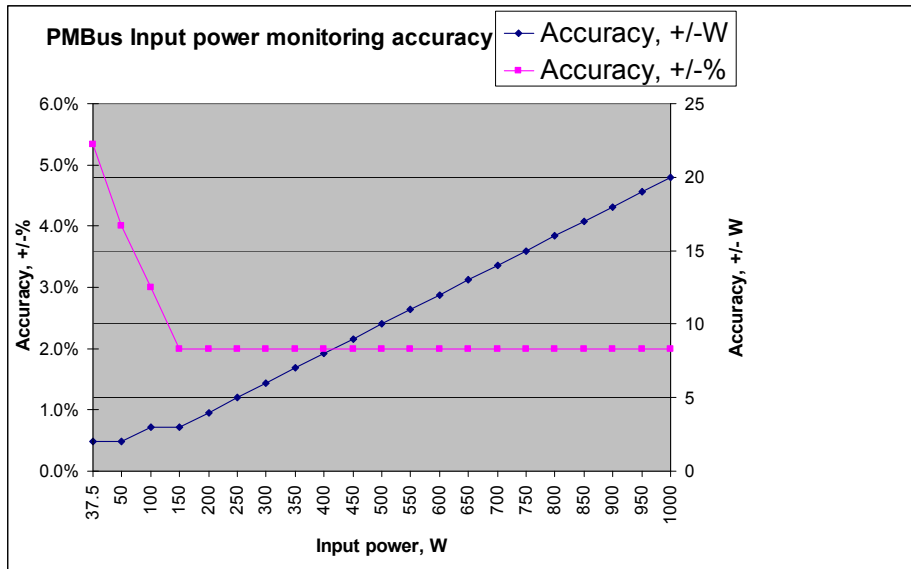

**Figure 16. PMBus Monitoring Accuracy**

## 4. Cooling Sub-System

---

The chassis cooling system contains the fan cooling sub-system of each node and common fan cooling in the power supply units. Both node fans and PSU fans work together as thermal solution to the chassis.

For each node, several components and configuration requirements make up the cooling sub-system. These include processors, chipsets, VR heatsinks, system fan module, CPU air duct, and drive bay population. All are necessary to provide and regulate the air flow and air pressure needed to maintain the system's thermals when operating at or below the maximum specified thermal limits.

In order to maintain the necessary airflow within the system, you must properly install the air duct, HDD dummy carrier, PSU dummy filler and the top cover.

Each node uses a variable fan speed control engine to provide adequate cooling for the node and whole system at various ambient temperature conditions, under various server workloads, and with the least amount of acoustic noise possible. The fans operate at the lowest speed for any given condition to minimize acoustics.

---

**Note:** The server system does not support redundant cooling fans. If any of the node fans fail, you must power down the respective node as soon as possible to replace the fan.

---

### 4.1 Processor Heatsink

A heatsink is included in the system package. This heatsink is designed for optimal cooling and performance. To achieve better cooling performance, you must properly attach the heatsink bottom base with TIM (thermal interface material). ShinEtsu\* G-751 or 7783D or Honeywell\* PCM45F TIM is recommended. The mechanical performance of the heatsink must satisfy mechanical requirement of Intel® Xeon® E5-2600 series processors. To keep chipsets and VR temperature at or below maximum temperature limit, the heatsink is required if necessary.

---

**Note:** The processor heatsink for CPU1 and CPU2 are different. FXXCA84X106HS (Cu base-Al fin Heatsink ) is for CPU1, while FXXE84X106HS (Al-extruded Heatsink) is for CPU2. Mislocating the heatsink will cause serious thermal damage!

---

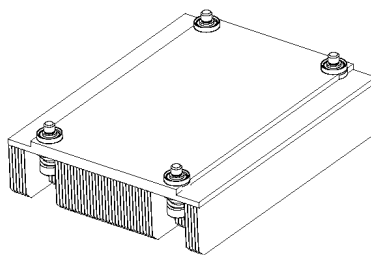
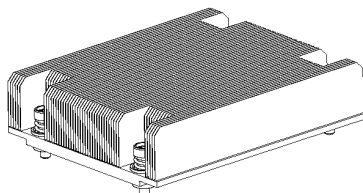
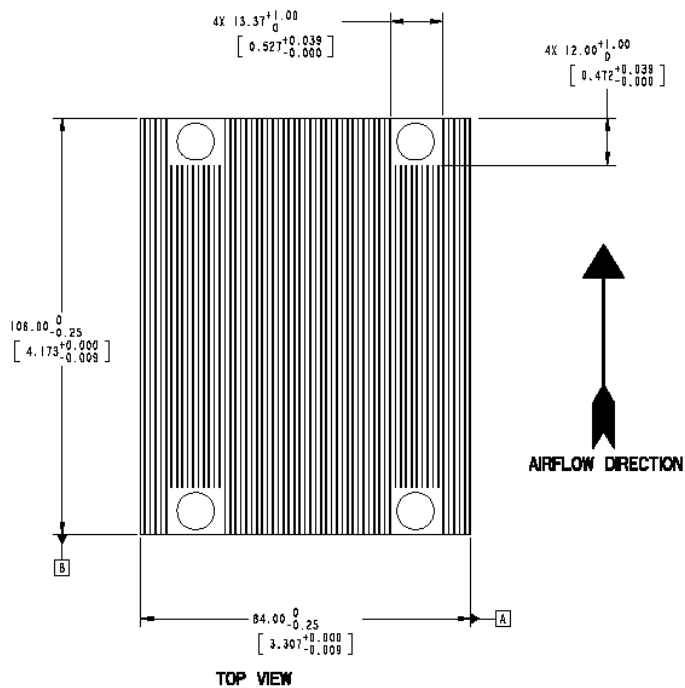

**Figure 17. Processor Heatsink Overview**

---

**Note:** The passive heatsink is Intel® standard thermal solution for 1U/2U rack chassis.

---

## 4.2 Node cooling Fans

The cooling subsystem for each node consists of three 40 x 40 x 56 dual rotor fan, and CPU air duct. These components provide the necessary cooling and airflow to the system node.

To maintain the necessary airflow within the system, the air duct and the top cover must be properly installed.



**Note:** The Intel® Server System H2000WP Family does not support redundant cooling. If one of the node fan fails, the respective node should be powered down as soon as possible to replace the failed fan.

Each fan within the node is capable of supporting multiple speeds. Fan speed changes automatically when internal ambient temperature of the system or processor temperature changes. The fan speed control algorithm is programmed into the server board's BIOS.

Each fan connector within the module supplies a tachometer signal that allows the BMC to monitor the status of each fan. If one of the fans should fail, the system fault LED on front panel will light.

The fan control signal is from BMC on mother board to Node Docking Board and then distribute to three sets of dual rotor fans. See below for detail.

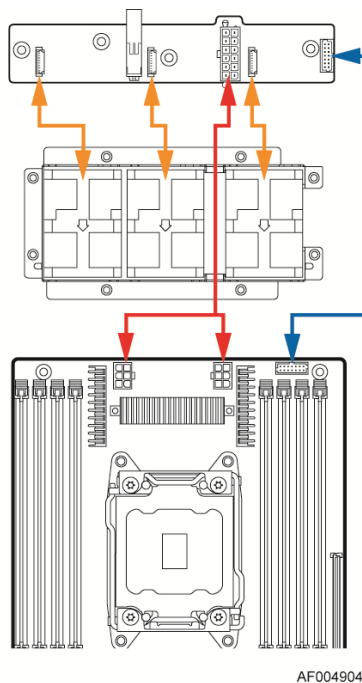

AF004904

<b>Yellow Lines:</b> fan cable connection
<b>Red line:</b> base board power cable connection
<b>Blue line:</b> fan control signal cable connection

**Figure 18. Node Fan Set and power/control Connection**

The fan connector pin-out definition is as follows:

**Table 32. 8-pin Connector Pin-Out for Node Dual Rotor Fans**

Pin	Signal Name	Description
1	GND	Ground

Pin	Signal Name	Description
2	P12V	Power Supply +12 V
3	Tach1 Out	FAN_TACH1 signal output
4	PWM1 In	PWM1 signal input
5	GND	Ground
6	P12V	Power Supply +12 V
7	Tach2 Out	FAN_TACH2 signal output
8	PWM1 In	PWM1 signal input

### 4.3 Power Supply Fan

Each power supply module supports one non-redundant dual rotor 40 mm fan. The fans control the cooling of the power supply and some drive bays. These fans are not replaceable. Therefore, if a power supply fan fails, you must replace the power supply module.

### 4.4 Air Duct Module

Each node requires the use of an air duct module to direct airflow over critical areas within the node. Before slide the node tray into chassis, make sure the air duct is installed properly.

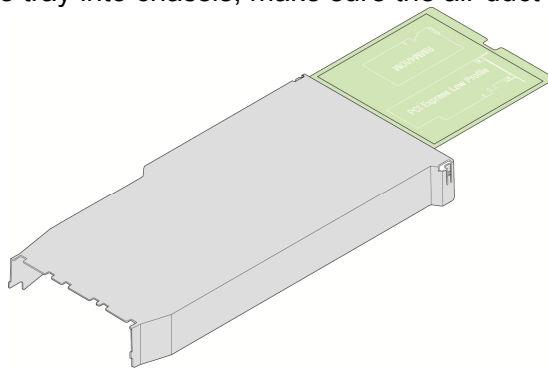

AF005993-1

Figure 19. Compute Node Air Duct

### 4.5 Drive Bay Population Requirement

In order to maintain system thermal requirements, you must fully populate all hard drive bays. Hard drive trays used for hot-swap drives must either have a hard drive installed or not have a hard drive installed.

If only one power supply unit is used, a PSU dummy filler must be used to match the airflow requirement.

---

**IMPORTANT:** If the drive bay is missing or not fully populated, the system will not meet the thermal cooling requirements of the processor, which will most likely result in degraded performance as a result of throttling or thermal shutdown of the system. It is recommended to keep/apply the dummy plastic blocker(as shipped with HDD carrier) on any blank HDD carrier.

---

## 5. System Boards in the Node Tray

The Node tray includes mother board, node docking board, bridge board and node fan set.

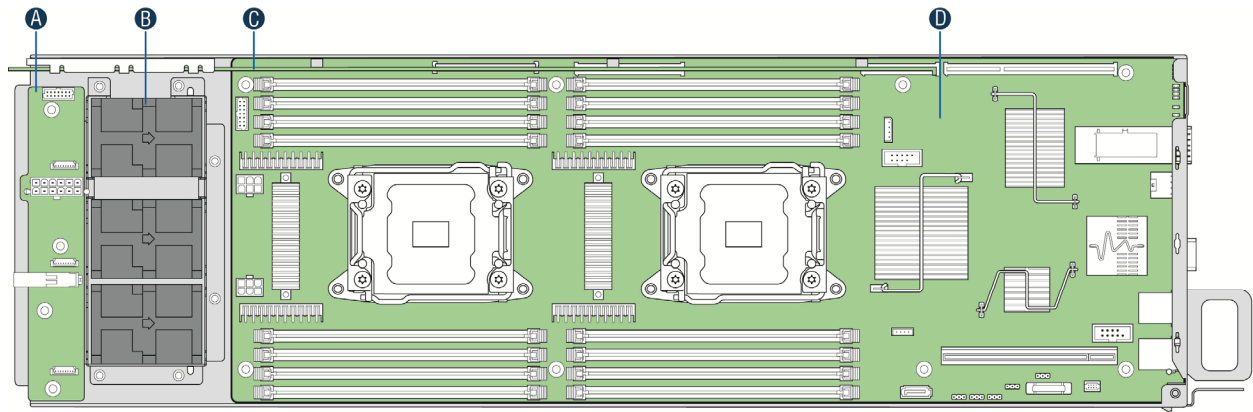

AF005079

<b>A</b>	Node Docking Board
<b>B</b>	Node Fan Set
<b>C</b>	Baseboard
<b>D</b>	Bridge Board

Figure 20. Compute Node Tray Overview

### 5.1 Node Docking Board

#### 5.1.1 Overview of Node Docking Board

The Node Docking Board provides hot swap docking of 12V main power between the compute node and the server. It supports three dual rotor fan connections, 12V main power hot swap controller and current sensing. The HW Power Docking Board is intended to support the usage of compute node of Intel® Server Board S2600WP family.

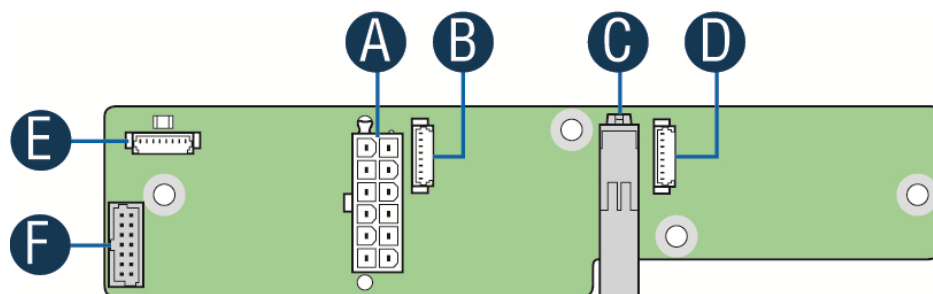

AF004430

<b>A</b>	2x6 pin Minifit Jr main power output connector
<b>B</b>	8 pin connector for node fan 2
<b>C</b>	12 pin connector for main power input
<b>D</b>	8 pin connector for node fan 3
<b>E</b>	8 pin connector for node fan 1
<b>F</b>	2x7 pin fan control connector

Figure 21. Node Docking Board

The Node Docking Board implements the below features:

- Main 12V hot swap connectivity between compute node and chassis power.
- Current sensing of 12V main power for use with node manager.
- One 2x6pin mini-fit jr high current connectors for cabling to either the HW baseboard or a GPGPU card. Different cable lengths will be needed for the different depth HW baseboards.
- 2x7pin fan single connector, discrete cabled to the HW baseboard.
- Three 8pin dual rotor fan connectors.
- Four loose screws used to secure board to the compute node.

### 5.1.2 Pinout definition on Node Docking Board

Below is a list of connector type and pin definition on Node Docking Board.

**Table 33. Main Power Input Connector**

Pin	Signal Description	Pin	Signal Description
Lower Blade (Circuit 1)			
1	GND	2	GND
3	GND	4	GND
5	GND	6	GND
Upper Blade (Circuit 2)			
7	P12V	8	P12V
9	P12V	10	P12V
11	P12V	12	P12V

**Table 34. Fan Control Signal Connector**

Pin	Signal Description	Pin	Signal Description
1	PWM1	2	Reserved
3	Tach0	4	Tach1
5	Tach2	6	Tach3
7	Tach4	8	Tach5
9	NODE_ON	10	GND
11	SMBUS_R4 CLK	12	SMBUS_R4 DAT
13	NODE_ADR0	14	NODE_PWRGD

**Table 35. Node Fan Connector**

Pin	Signal Description
1	GND
2	P12V
3	TACH1
4	PWM1
5	GND
6	P12V
7	TACH2
8	PWM1

**Table 36. Main Power Output Connector**

Pin	Signal Description	Pin	Signal Description
1	GND	7	P12V_HS
2	GND	8	P12V_HS
3	GND	9	P12V_HS
4	GND	10	P12V_HS
5	GND	11	P12V_HS
6	GND	12	P12V_HS

## 5.2 Bridge Board

### 5.2.1 Overview of Bridge Board

The Bridge Board is a common board across all baseboards going into the H2000WP serials server chassis. The Bridge Board provides hot swap interconnect of all electrical signals to the backplane of the server chassis (except for main 12V power). It supports up to 4x lanes of SAS/SATA, a 7-pin SATA connector for SATA DOM devices, and type-A USB connector for USB flash device. One Bridge Board is used per one compute node. The Bridge Board is secured with three loose screws to the compute node tray.

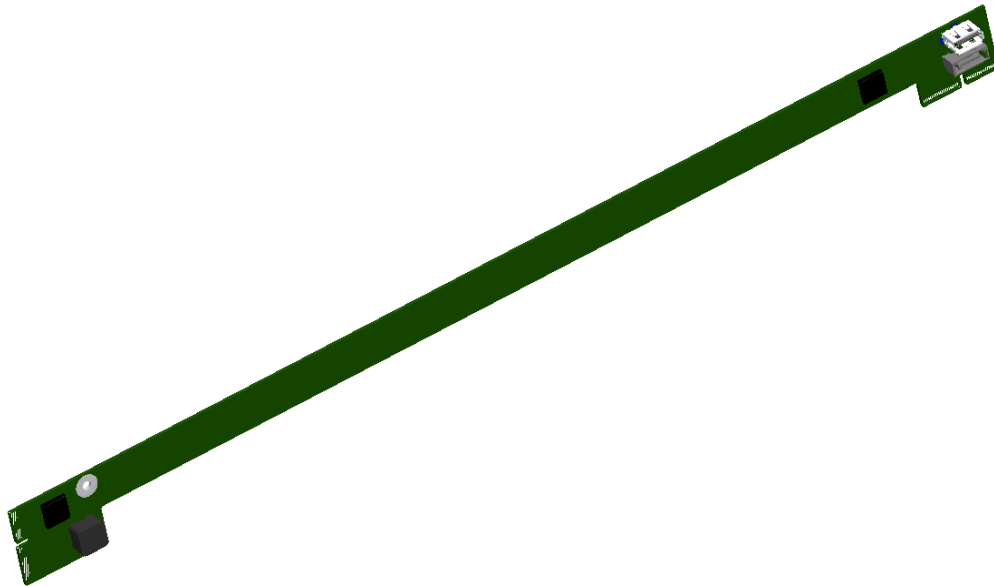
**Figure 22. Bridge Board Overview**

Bridge board passes all electrical connectivity through a 2x40pin card edge hot swap interconnect between compute node and chassis backplane. The bridge board passes the follow features (per compute node) to the backplane of the server:

- 4x 6Gb SAS/SATA ports for HSBP drives.
- Two x4 lane 6Gb SAS/SATA re-drivers.
- Four chassis ID signals to determine the physical location of the compute node.
- One SGPIO SFF-8485 interface to the HSBP microcontroller.

- 5V\_AUX power generated on HSBP and provided to the compute node.
- 3.3V power generated on HSBP and provided to bridge board to run SAS/SATA re-drivers.
- Global PMBus alert signal for CLST support.
- Four SMB bus interfaces:
  - SMBUS R1 - For chassis temp sensor and chassis FRU EEPROM device
  - SMBUS R5 - Connectivity to up to two HSBP controllers and one shared .12V current monitoring device.
  - SMBUS R7 - Connectivity to up to two common redundant power supply (CRPS) module PMBus
  - IPMB - For OEM requirement, not used on EPSD HW servers.
  - Front panel button signals: Power, reset, NMI, ID.
  - Front panel LEDs signals: Power, fault, status, fabric activity, ID, HDD activity
- One 7-pin 6Gb SATA port connector for DOM device docking to the bridge board.
- USB2.0 interface to a 4-pin type-A connector for flash device docking to bridge board.
- 2-Pin 5V\_AUX power for the SATA DOM in need of cabling power.
- Power connector for SATA DOM.

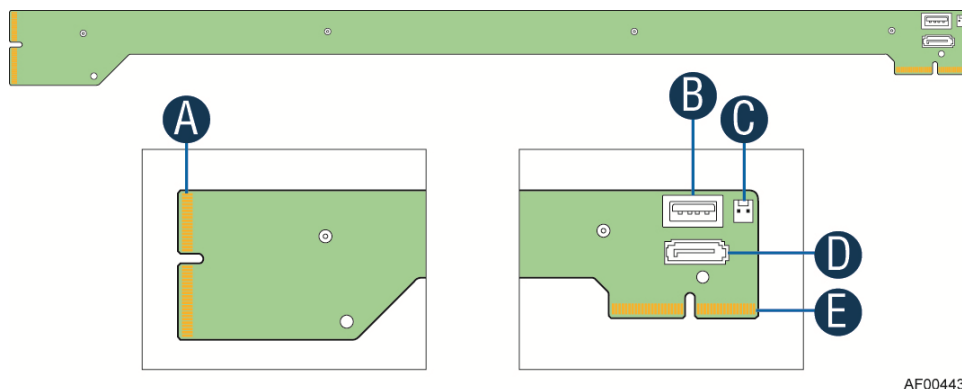

AF004431

<b>A</b>	2x40 pin card edge connector (to backplane)
<b>B</b>	USB 2.0 Type-A connector
<b>C</b>	2-pin 5V_AUX power
<b>D</b>	AHCI SATA0 DOM port connector
<b>E</b>	2x40 pin card edge connector (to baseboard slot))

**Figure 23. Connectors on Bridge Board**

## 5.2.2 Pinout definition on Bridge Board

The table below lists the connector type and pin definition for a Bridge Board.

**Table 37. Card Edge Connector Pinout**

Pin	Signal Description	Pin	Signal Description
1	5V Aux	2	5V Aux
3	SATA0_TXN	4	USB2_OC
5	SATA0_TXP	6	GND
7	GND	8	SATA0_RXN
9	NODE_PRESENT_N (GND)	10	SATA0_RXP
11	ALL_NODE_OFF	12	GND
13	spare	14	USB2_P0P
15	GND	16	USB2_P0N
17	IPMB-Data	18	GND
19	IPMB-Clk	20	FP HDD_ACT_LED_N
21	GND	22	FP Activity LED_N
23	SMBUS_R1 DATA	24	FP Health LEDA_N
25	SMBUS_R1 CLK	26	FP Health LEDG_N
27	GND	28	FP PWR LED_N
29	SMBUS_R5 DATA	30	FP ID LED_N
31	SMBUS_R5 CLK	32	FP ID BTN_N
33	GND	34	FP RST BTN_N
35	SMBUS_R7 DATA	36	FP PWR BTN_N
37	SMBUS_R7 CLK	38	FP NMI BTN_N
39	GND	40	SPA_SOUT_N
41	PMBUS Alert_N	42	SPA_SIN_N
43	NODEx_ON_N	44	ID3
45	SGPIO DATA IN	46	ID2
47	SGPIO Data Out	48	ID1
49	SGPIO LD	50	ID0
51	SPKR	52	SGPIO CLK
53	GND	54	GND
55	SAS3_RX	56	SAS3_TX
57	SAS3_RX	58	SAS3_TX
59	GND	60	GND
61	SAS2_TX	62	SAS2_RX
63	SAS2_TX	64	SAS2_RX
65	GND	66	GND
67	SAS1_RX	68	SAS1_TX
69	SAS1_RX	70	SAS1_TX
71	GND	72	GND
73	SAS0_TX	74	SAS0_RX
75	SAS0_TX	76	SAS0_RX
77	GND	78	GND
79	P3V3 (HSBP Side) and GND (HW Baseboard Side)	80	P3V3 (HSBP Side) and SATA_SAS_N (HW Baseboard Side)

The SATA DOM used on SATA0 port can be either powered by the SATA port, or using external power from 5V-AUX connector.

**Table 38. AHCI SATA0 DOM Connector Pinout**

Pin	Signal Description
1	GND
2	SATA0_TXP
3	SATA0_TXN
4	GND
5	SATA0_RXN
6	SATA0_RXP
7	P5V_SATA/GND

**Table 39. USB 2.0 Type-A Connector Pinout**

Pin	Signal Description
1	P5V_USB
2	USB2_P0N
3	USB2_P0P
4	GND

**Table 40. 5V\_AUX Power Connector Pinout**

Pin	Signal Description
1	GND
2	P5V



## 6. Hard Disk Drive Support

The server system provides two SKUs to support different types of Hard Disk Drives (HDD):

- H2312WP : Supports 12x 3.5" HDD
- H2216WP : Supports 16x 2.5" HDD

### 6.1 Hard Disk Drive Bays Scheme

The server system H2000 chassis can support up to twelve carrier-mounted SATA/SAS 3.5-inch hard disk drives, or sixteen carrier-mounted SATA/SAS 2.5-inch hard disk drives. The drives may be “electrically” hot-swapped while the system power is applied, but you must take caution before hot-swapping while the system is functioning under operating system/application control or data may be lost.

Below are hard disk drive distribution schemes on different SKUs of H2000 chassis family.

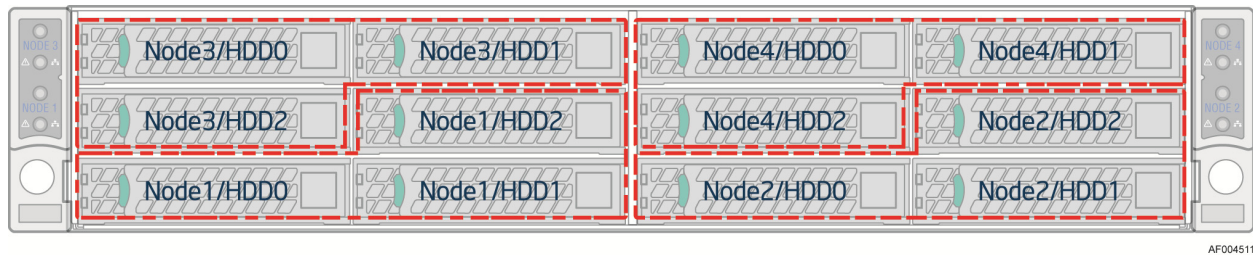

AF004511

Figure 24. HDD Scheme for H2312WPGR

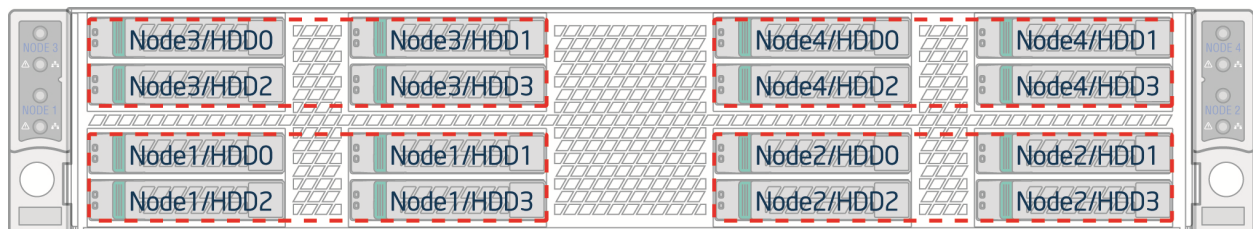

AF004512

Figure 25. HDD Scheme for H2216WPGR

**Note:** If a failed drive needs replacing, it is recommended you replace it with the same manufacturer, model, and capacity.

### 6.2 Hard Drive Carrier

There are two types of HDD carriers for two chassis SKUs respectively:

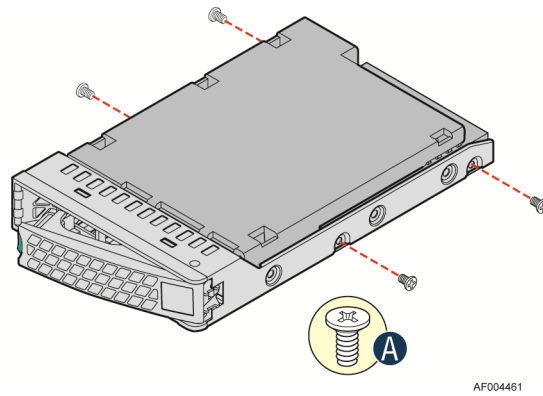

**Figure 26. 3.5-inch HDD Assembly Overview**

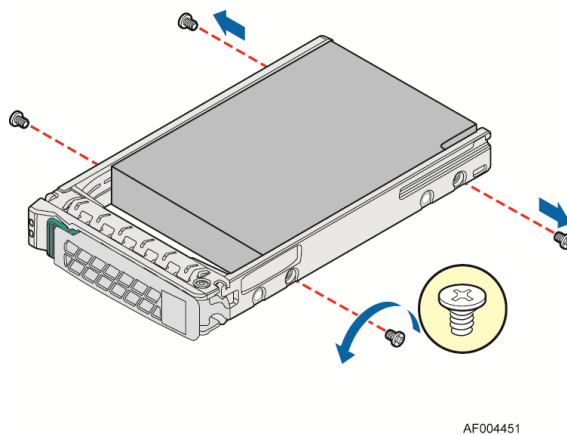

**Figure 27. 2.5-inch HDD Assembly Overview**

Hot-swap drive carriers make insertion and extraction of the drive from the system very simple. Each type of drive carrier has its own latching mechanism, which is used to both insert and extract drives from the chassis and lock the carrier in place. Each type of drive carrier supports two light pipes to direct light from the drive status LEDs on the backplane to the carrier's face allowing it to be viewable from the front of the system.

### 6.3 Hot-Swap Hard Drive Support

Both the Intel® Server System H2312WPGR and H2216WPGR can support hot-swap SATA/SAS hard drives. Hard drives interface with the passive backplane through a blind mate connection when drives are installed into a hard drive bay using hot-swap drive carriers.

The passive backplane acts as an intermediate pass-through interface board where SATA/SAS ports of SCU0 from server board are hard wired to the backplane. The on board Intel® C600 Chipset (PCH) provides the necessary drive interface.

Each compute node in the system has dedicated Hot Swap Controller (HSC) to manage three or four HDDs. There are totally four sets of independent Programmable System On Chip (PSOC) on the backplane, to function as HSC respectively to four compute nodes.

The following sections describe the feature and connections between the backplane and server board.

### 6.3.1 Backplane Feature set:

- Common HSBP Microcontroller Cypress\* PSoC 1 part
- **H2312WPGR:** 12x SAS/SATA 3.5" HDDs at 6Gb/s SAS/SATA or slower speeds, divided into 4 groups of three hot swap hard drives. Each HDD group is associated with one of the four compute nodes respectively in the 2U chassis.
- **H2216WPGR:** 16x SAS/SATA 2.5" HDDs at 6Gb/s SAS/SATA or slower speeds, divided into 4 groups of four hot swap hard drives. Each HDD group is associated with one of the four compute nodes respectively in the 2U chassis.
- One SGPIO SFF-8485 interface per compute node, total of four SGPIO on the backplane.
- Three SMB interfaces supported on the HSBP:
  - SMBUS R1 - For chassis temp sensor and chassis FRU EEPROM device.
  - SMBUS R5 - Connectivity to up to two HSBP controllers and one shared 12V current monitoring device.
  - SMBUS R7 - Connectivity to up to two common redundant power supply (CRPS) module PMBus.
- Integrated front panel control connectors
- Status LED and Activity LED for each hard disk drive.
- 5V\_AUX switcher regulator (from 12V and 12VSB) for HDD power and for compute nodes.
- Each grouping of HDD slots has switches for 5V and 12V power, only when corresponding compute node is plugged in and operating will power be provided to the HDDs.
- 3.3V switcher regulator (from 12V) to power microcontroller, SAS/SATA re-drivers on the bridge board and various other components.
- 3.3V\_AUX linear regulator (from 5V\_AUX) for temp sensor, and chassis FRU EEPROM located on the HSBP.
- Four 80-pin bridge board connectors, one per compute node.
- Four compute node main power connectors, one per compute node.
- Four 2x9pin power cable connections and one 2x9pin power control cable connections. These cables are routing to two power distribution boards (PDB).
- Shared speaker for all compute nodes.

### 6.3.2 Backplane Block Diagram

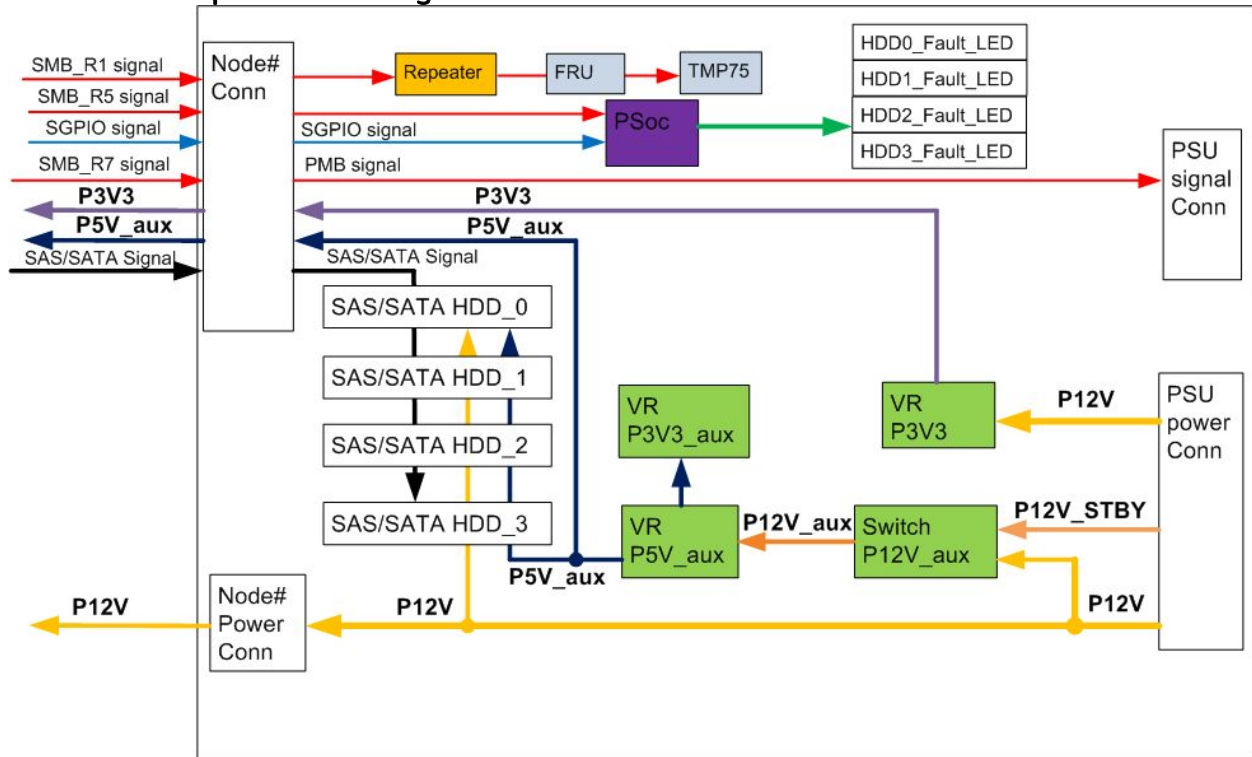
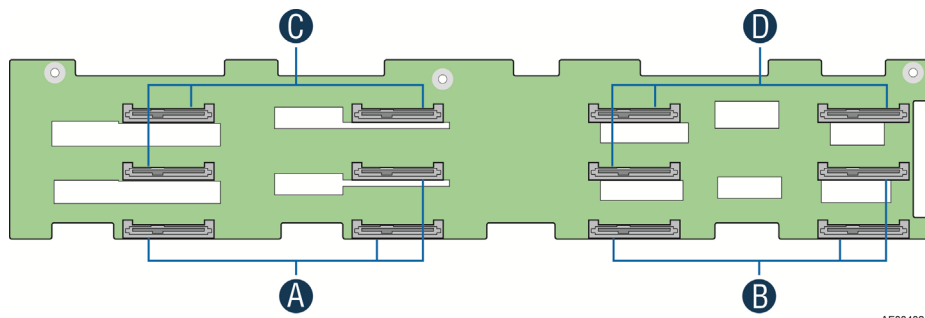

Figure 28. Passive Backplane Block Diagram (for one node)

### 6.3.3 3.5" Hot Swap Backplane Connector scheme

The following diagrams show the layout of major components and connectors for 3.5" Hot Swap backplane.



AF004321

<b>A</b>	SATA/SAS connectors for Node 1
<b>B</b>	SATA/SAS connectors for Node 2
<b>C</b>	SATA/SAS connectors for Node 3
<b>D</b>	SATA/SAS connectors for Node 4

Figure 29. 3.5" Backplane Component and Connectors (Front View)

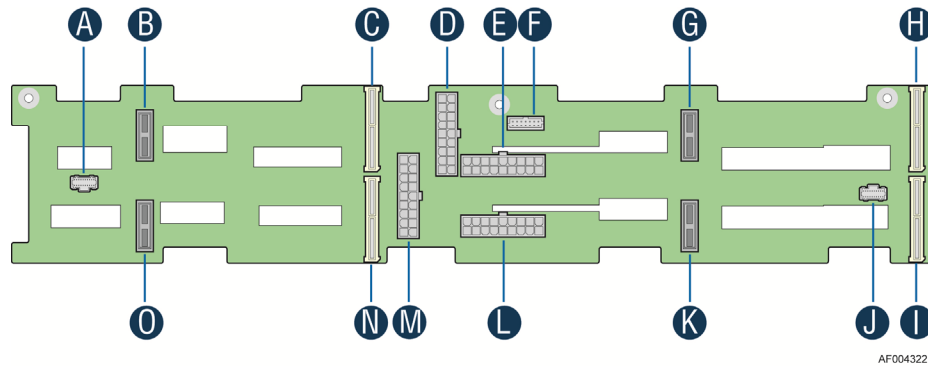

AF004322

<b>A</b>	20-pin Front Panel cable connector for Node 2, 4
<b>B</b>	2Blade Compute Node Power connector for Node 4
<b>C</b>	2x40 pin Bridge Board connector for Node 4
<b>D</b>	2x9 pin Power supply input connector
<b>E</b>	2x9 pin Power supply input connector
<b>F</b>	2x7 pin Power Control cable connector
<b>G</b>	2Blade Compute Node Power connector for Node 3
<b>H</b>	2x40 pin Bridge Board connector for Node 3
<b>I</b>	2x40 pin Bridge Board connector for Node 1
<b>J</b>	20-pin Front Panel cable connector for Node 1, 3
<b>K</b>	2Blade Compute Node Power connector for Node 1
<b>L</b>	2x9 pin Power supply input connector
<b>M</b>	2x9 pin Power supply input connector
<b>N</b>	2x40 pin Bridge Board connector for Node 2
<b>O</b>	2Blade Compute Node Power connector for Node 2

**Figure 30. 3.5" Backplane Component and Connectors (Back View)**

### 6.3.4 2.5" Hot Swap Backplane Connector scheme

The following diagrams show the layout of major components and connectors for 2.5" Hot Swap backplane.

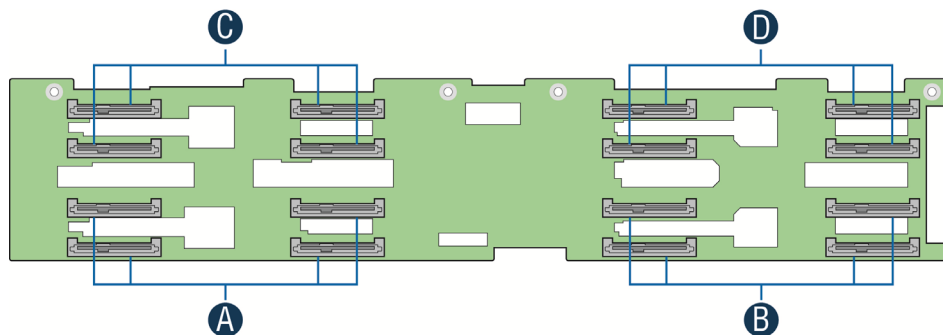

AF004314

<b>A</b>	SATA/SAS connectors for Node 1
<b>B</b>	SATA/SAS connectors for Node 2
<b>C</b>	SATA/SAS connectors for Node 3
<b>D</b>	SATA/SAS connectors for Node 4

**Figure 31. 2.5" Backplane Component and Connectors (Front View)**

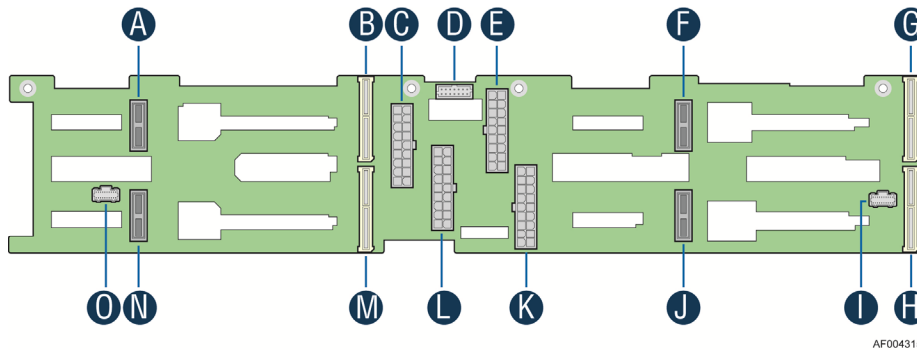

<b>A</b>	2Blade Compute Node Power connector for Node 4
<b>B</b>	2x40 pin Bridge Board connector for Node 4
<b>C</b>	2x9 pin Power supply input connector
<b>D</b>	2x7 pin Power Control cable connector
<b>E</b>	2x9 pin Power supply input connector
<b>F</b>	2Blade Compute Node Power connector for Node 3
<b>G</b>	2x40 pin Bridge Board connector for Node 3
<b>H</b>	2x40 pin Bridge Board connector for Node 1
<b>I</b>	20-pin Front Panel cable connector for Node 1, 3
<b>J</b>	2Blade Compute Node Power connector for Node 1
<b>K</b>	2x9 pin Power supply input connector
<b>L</b>	2x9 pin Power supply input connector
<b>M</b>	2x40 pin Bridge Board connector for Node 2
<b>N</b>	2Blade Compute Node Power connector for Node 2
<b>O</b>	20-pin Front Panel cable connector for Node 2, 4

**Figure 32. 2.5" Backplane Component and Connectors (Back View)**

### 6.3.5 Backplane LED Support

The backplanes support both HDD online and activity/fault LEDs for each of the hard drive connectors. A light duct in HDD tray is used to conduct LED light to front panel. The following lists LED functionality.

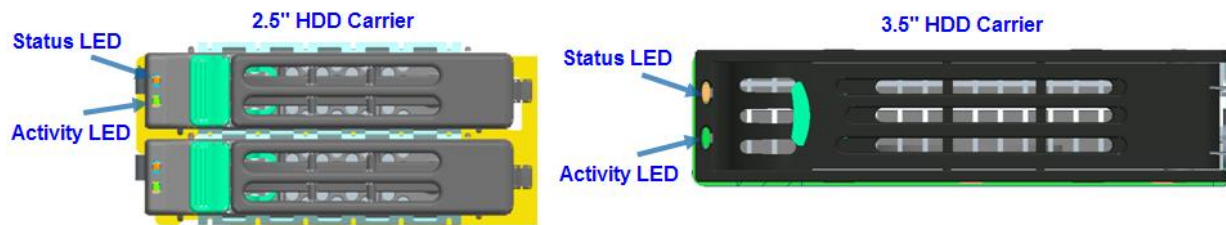

**Figure 33. Hard Drive Carrier LED**

General HDD LED functionality is displayed below:

**Table 41. Hard Drive Carrier Status LED Functions**

<b>Amber</b>	Off	No access and no fault
	Solid On	Hard Drive Fault has occurred
	Blink	Raid rebuild in progress (1hz) Identify (2hz)

**Table 42. Hard Drive Carrier Activity LED Functions**

	Condition	Drive Type	Behavior
<b>Green</b>	Power on with no drive activity.	SAS	LED stays on
		SATA	LED stays off
	Power on with drive activity.	SAS	LED blinks off when processing a command
		SATA	LED blinks off when processing a command
	Power on and drive spun down.	SAS	LED stays off
		SATA	LED stays off
	Power on and drive spinning up.	SAS	LED blinks
		SATA	LED stays off

### 6.3.6 Backplane Connector Definition

The backplanes include several different connectors. This section defines the purpose and pin out associated with each.

#### 1. 2x9 Pin Power Input Connector

The backplane is powered by +12V and +12V<sub>STB</sub> from PDB of CRPS. The input power is distributed by backplane to all four nodes.

**Table 43. Backplane Input Power Connector Pin-out**

Pin	Signal Description	Pin	Signal Description
2	P12V	1	GND
4	P12V	3	GND
6	P12V	5	GND
8	P12V	7	GND
10	P12V	9	GND
12	P12V	11	GND

Pin	Signal Description	Pin	Signal Description
14	P12V	13	GND
16	P12V	15	GND
18	P12V	17	GND

## 2. 2-Blade Compute Node Power Connector

The backplane provides main power to compute node through 2Blade power connector.

**Table 44. 2-Blade Compute Node Power Connector Pin-out**

Pin	Signal Description	Pin	Signal Description
Lower Blade (Circuit 1)			
1	GND	2	GND
3	GND	4	GND
5	GND	6	GND
7	GND	8	GND
Upper Blade (Circuit 2)			
9	P12V	10	P12V
11	P12V	12	P12V
13	P12V	14	P12V
15	P12V	16	P12V

## 3. 2x40 Pin Bridge Board Connector

The Compute Node provides four SATA/SAS ports (in SCU0) to backplane, together with front panel control signals and SMBus.

**Table 45. 2x40 Pin Connector Pin-out for Node Bridge Board**

Pin	Signal Description	Pin	Signal Description
1	5V_AUX	2	5V_AUX
3	SATA0_TXN	4	USB2_OC
5	SATA0_TXP	6	GND
7	GND	8	SATA0_RXN
9	NODE_Present_N (GND)	10	SATA0_RXP
11	ALL_NODE_OFF	12	GND
13	spare	14	USB2_P0P
15	GND	16	USB2_P0N
17	IPMB-Data	18	GND
19	IPMB-Clk	20	FP HDD_ACT_LED_N
21	GND	22	FP Activity LED_N
23	SMBUS_R1 DATA	24	FP Health LEDA_N
25	SMBUS_R1 CLK	26	FP Health LEDG_N
27	GND	28	FP PWR LED_N
29	SMBUS_R5 DATA	30	FP ID LED_N
31	SMBUS_R5 CLK	32	FP ID BTN_N
33	GND	34	FP RST BTN_N



Pin	Signal Description	Pin	Signal Description
35	SMBUS_R7 DATA	36	FP PWR BTN_N
37	SMBUS_R7 CLK	38	FP NMI BTN_N
39	GND	40	SPA_SOUT_N
41	PMBUS Alert_N	42	SPA_SIN_N
43	NODEx_ON_N	44	ID3
45	SGPIO DATA IN	46	ID2
47	SGPIO Data Out	48	ID1
49	SGPIO LD	50	ID0
51	SPKR	52	SGPIO CLK
53	GND	54	GND
55	SAS3_RX	56	SAS3_TX
57	SAS3_RX	58	SAS3_TX
59	GND	60	GND
61	SAS2_TX	62	SAS2_RX
63	SAS2_TX	64	SAS2_RX
65	GND	66	GND
67	SAS1_RX	68	SAS1_TX
69	SAS1_RX	70	SAS1_TX
71	GND	72	GND
73	SAS0_TX	74	SAS0_RX
75	SAS0_TX	76	SAS0_RX
77	GND	78	GND
79	3.3V	80	3.3V

#### 4. 20-Pin Front Panel Connector

The backplanes provide connectors for front panel control signals. Each connector integrates the control signals of two compute nodes.

**Table 46. Front Panel Connector Pin-out**

Pin	Signal Description
1	GND
2	FP1_PWR_BTN_N
3	FP1_RST_BTN_N
4	FP1_ID_BTN_N
5	P5VSB
6	FP1_PWR_LED_N
7	FP1_HEALTH_LEDG_N
8	FP1_HEALTH_LED_A_N
9	FP1_ACTIVITY_LED_N
10	FP1_ID_LED_N
11	GND
12	FP2_PWR_BTN_N
13	FP2_RST_BTN_N
14	FP2_ID_BTN_N
15	P3V3SB

Pin	Signal Description
16	FP2_PWR_LED_N
17	FP2_HEALTH_LEDG_N
18	FP2_HEALTH_LED_A_N
19	FP2_ACTIVITY_LED_N
20	FP2_ID_LED_N

## 5. 2x7 Pin Power Supply Control Signal Connector

The backplanes provide power supply control signals, together with PMBus functionality integrated.

**Table 47. Power Supply Control Connector Pin-out**

Pin	Signal Description	Pin	Signal Description
1	SMBUS_R7_DATA	2	A0
3	SMBUS_R7_CLK	4	PSON_N
5	PMBUS_ALERT_N	6	12V_RS_RTN
7	PWROK	8	12V_RS
9	Reserved	10	PDU1-12VSB
11	PDU1-12VSB	12	PDU2-12VSB
13	PDU2-12VSB	14	Reserved

## 7. Front Panel Control and Indicators

The Intel® Server System H2000WP family Front Control Panel is integrated with rack handles at the both sides of the chassis. Each control panel contains two sets of node control buttons and status LEDs. The control panel assembly is pre-assembled and fixed with the rack handles.

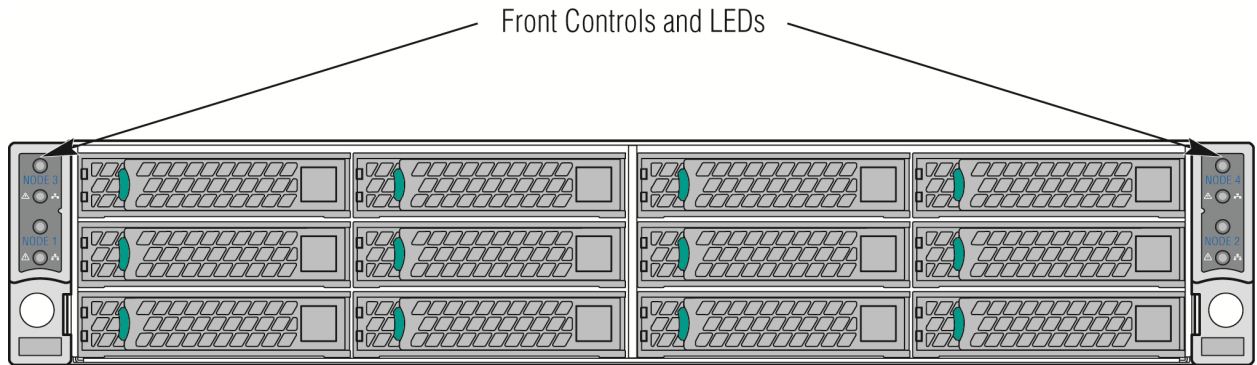

AF004636

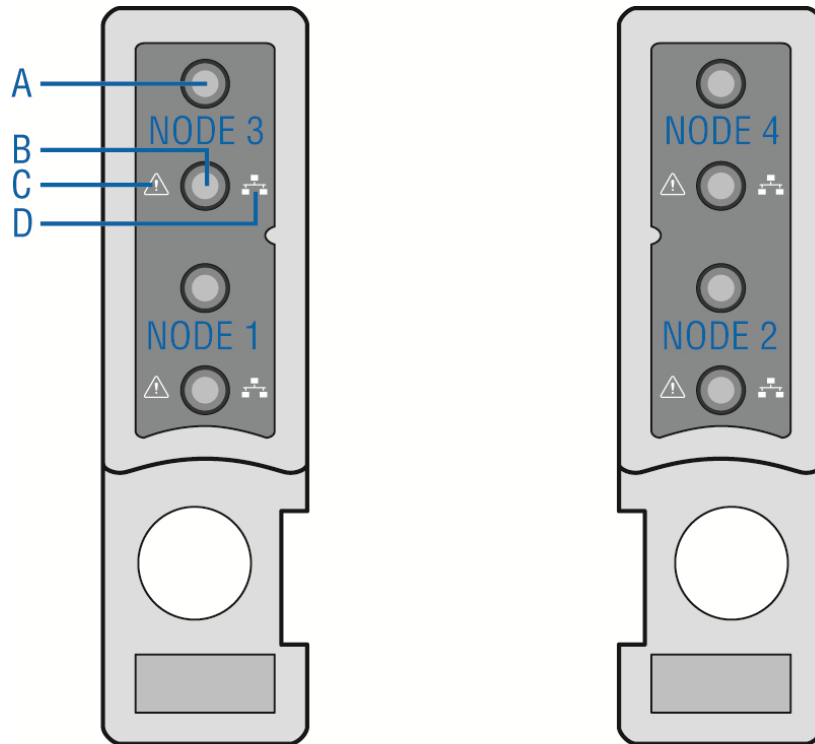

AF004634

<b>A</b>	System Power Button with LED
<b>B</b>	System ID LED Button
<b>C</b>	System Status LED
<b>D</b>	Network Link/Activity LED

**Figure 34. Front Control Panel**

## 7.1 Control Panel Button

The following table lists the control panel features and functions. The control panels features a system power button.

**Table 48. Front Control Button Function**

Feature	Function
Power Button with Power LED	Toggles the system power on/off. This button also integrates the power LED.
System ID Button with ID LED	Toggles between ID LED on and off

## 7.2 Control Panel LED Indicators

The control panel houses independent two LEDs and two button integrated LEDs for each node, which are viewable to display the system's operating status. The following table identifies each LED and describes their functionality.

**Table 49. Front LED Indicator Functions**

LED Indicator	Color	Condition	What it describes
Power	Green	On	Power On/ACPI S0 state
	Green	Blink	Sleep /ACPI S1 state
	-	Off	Power Off /ACPI S5 state
LAN (i350 Dual NIC)	Green	On	LAN Link no Access
	Green	Blink	LAN Activity
	-	Off	No Link
System Status	Green	On	System Ready/No Alarm
	Green	Blink	System ready, but degraded: redundancy lost such as the power supply or fan failure; non-critical temp/voltage threshold; battery failure; or predictive power supply failure.
	Amber	On	Critical Alarm: Critical power modules failure, critical fans failure, voltage (power supply), critical temperature and voltage
	Amber	Blink	Non-Critical Alarm: Redundant fan failure, redundant power module failure, non-critical temperature and voltage
	-	Off	Power off: System unplugged Power on: System powered off and in standby, no prior degraded\non-critical\critical state

**Notes:**

1. Blink rate is ~1 Hz at 50% duty cycle.
2. It is also off when the system is powered off (S5) or in a sleep state (S1).
3. The power LED sleep indication is maintained on standby by the chipset. If the system is powered down without going through the BIOS, the LED state in effect at the time of power off is restored when the system is powered on until the BIOS clear it.
4. If the system is not powered down normally, it is possible the Power LED will blink at the same time the system status LED is off due to a failure or configuration change that prevents the BIOS from running.

## 7.2.1 Power/Sleep LED

**Table 50. Power LED Operation**

State	Power Mode	LED	Description
Power Off	Non-ACPI	Off	System power is off and the BIOS has not initialized the chipset.
Power On	Non-ACPI	Solid On	System power is on but the BIOS has not yet initialized the chipset.
S5	ACPI	Off	Mechanical is off and the operating system has not saved any context to the hard disk.
S1 Sleep	ACPI	Blink	DC power is still on. The operating system has saved context and gone into a level of low-power state.
S0	ACPI	Solid On	System and the operating system are up and running.

**Note:** Blink rate is ~ 1Hz at 50% duty cycle.

## 7.2.2 System Status LED

**Table 51. System Status LED Operation**

Color	State	Criticality	Description
Off	N/A	Not ready	Power off or BMC initialization completes if no degraded, non-critical, critical, or non-recoverable conditions exist after power cable plug in
Green/ Amber	Both Solid On	Not ready	Pre DC Power On – 15-20 second BMC Initialization when AC is applied to the server. The system will not POST until BMC initialization completes.
Green	Solid on	Ok	System ready
Green	Blink	Degraded	<p>BIOS detected</p> <ol style="list-style-type: none"> <li>Unable to use all of the installed memory (more than one DIMM installed).<sup>1</sup></li> <li>In a mirrored configuration, when memory mirroring takes place and system loses memory redundancy. This is not covered by (2).<sup>1</sup></li> <li>PCI Express* correctable link errors.</li> </ol> <p>Integrated BMC detected</p> <ol style="list-style-type: none"> <li>One of redundant power supplies not present.</li> <li>CPU disabled – if there are two CPUs and one CPU is disabled.</li> <li>Fan alarm – Fan failure. Number of operational fans should be more than minimum number needed to cool the system.</li> <li>Non-critical threshold crossed – Temperature, voltage, power nozzle, power gauge, and PROCHOT2 (Therm Ctrl) sensors.</li> <li>Battery failure.</li> <li>Predictive failure when the system has redundant power supplies.</li> </ol>
Amber	Blink	Non-critical	<p>Non-fatal alarm – system is likely to fail</p> <p><b>BIOS Detected</b></p> <ol style="list-style-type: none"> <li>In non-mirroring mode, if the threshold of ten correctable errors is crossed within the window.<sup>1</sup></li> <li>PCI Express* uncorrectable link errors.</li> </ol> <p><b>Integrated BMC Detected</b></p> <ol style="list-style-type: none"> <li>Critical threshold crossed – Voltage, temperature, power nozzle, power gauge, and PROCHOT (Therm Ctrl) sensors.</li> </ol>

Color	State	Criticality	Description
			2. VRD Hot asserted. 3. One of the redundant power supplies failed. 4. Minimum number of fans to cool the system are not present or have failed.
Amber	Solid on	Critical, non-recoverable	Fatal alarm – system has failed or shutdown <b>BIOS Detected</b> 1. DIMM failure when there is one DIMM present and no good memory is present. <sup>1</sup> 2. Run-time memory uncorrectable error in non-redundant mode. <sup>1</sup> 3. CPU configuration error (for instance, processor stepping mismatch). <b>Integrated BMC Detected</b> 1. CPU CATERR signal asserted. 2. CPU 1 is missing. 3. CPU THERMTRIP. 4. System cooling fan failure. 5. No power good – redundant power fault. <ul style="list-style-type: none"> <li>– Power Unit Redundancy sensor – Insufficient resources offset (indicates not enough power supplies are present).</li> </ul>

**Notes:**

1. The BIOS detects these conditions and sends a *Set Fault Indication* command to the Integrated BMC to provide the contribution to the system status LED.
2. Blink rate is ~ 1Hz at 50% duty cycle.

### 7.2.3 System Status LED – BMC Initialization

When power is first applied to the system and 5V-STBY is present, the BMC controller on the server board requires 15-20 seconds to initialize. During this time, the system status LED will be solid on, both amber and green. Once BMC initialization has completed, the status LED will stay green solid on. If power button is pressed before BMC initialization completes, the system will not boot to POST.

## 8. Configuration Jumpers

The following table provides a summary and description of configuration, test, and debug jumpers on the Intel® Server Board S2600WP, which is used in Intel® Server System H2000WP Family as Compute Node.

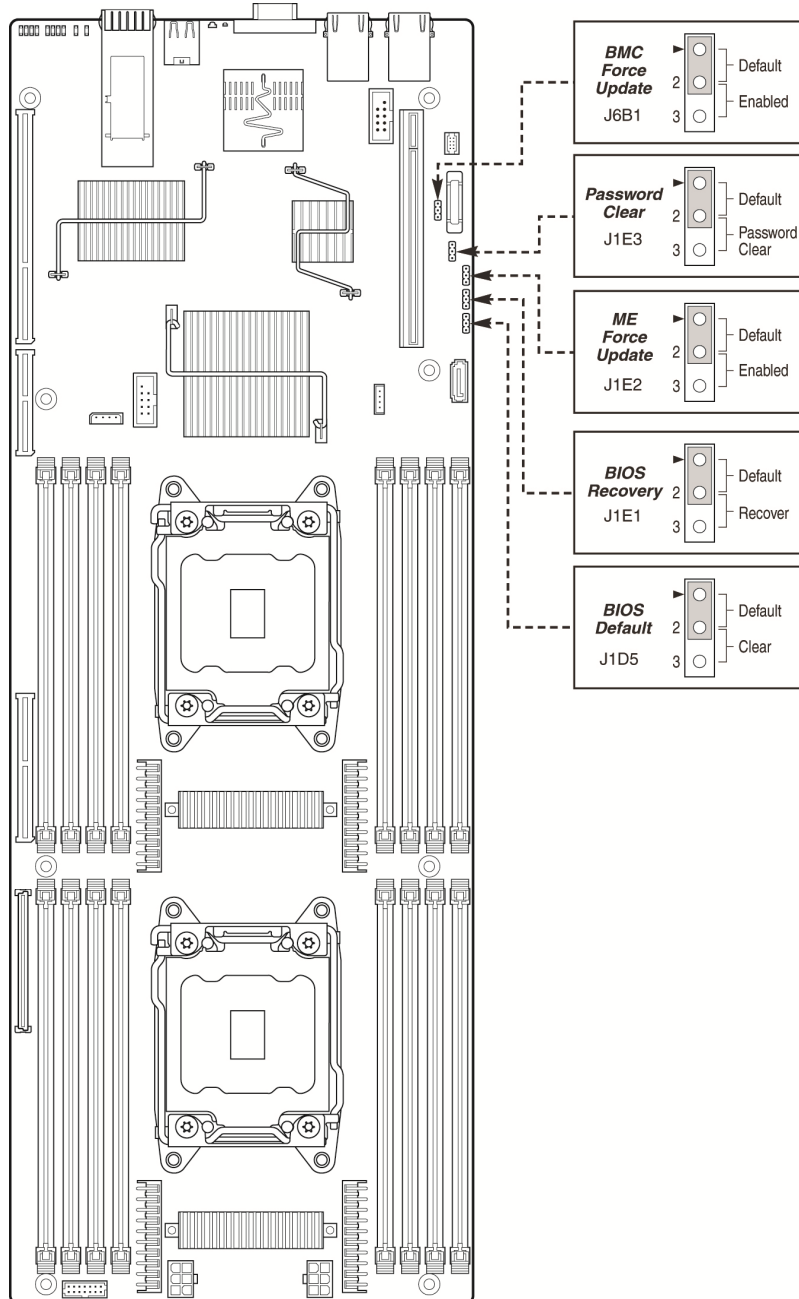

AF004672

Figure 35. Jumper Locations and Functions

**Table 52. Force Integrated BMC Update Jumper**

Jumper Name	Jumper Position	Mode of Operation	Note
J6B1: BMC Force Update jumper	1-2	Normal	Normal mode
	2-3	Update	BMC in force update mode
J1E2: ME Force Update	1-2	Normal	Normal mode
	2-3	Update	ME in force update mode
J1E3: Password Clear	1-2	Normal	Normal mode, password in protection
	2-3	Clear Password	BIOS password is cleared
J1E1: BIOS Recovery Mode	1-2	Normal	Normal mode
	2-3	Recovery	BIOS in recovery mode
J1D5: BIOS Default	1-2	Normal	Normal mode
	2-3	Clear BIOS Settings	BIOS settings are reset to factory default

## 8.1 Force Integrated BMC Update (J6B1)

When performing a standard BMC firmware update procedure, the update utility places the BMC into an update mode, allowing the firmware to load safely onto the flash device. In the unlikely event the BMC firmware update process fails due to the BMC not being in the proper update state, the server board provides a BMC Force Update jumper (J6B1) which will force the BMC into the proper update state. The following procedure should be followed in the event the standard BMC firmware update process fails.

**Table 53. Force Integrated BMC Update Jumper**

Jumper Position	Mode of Operation	Note
1-2	Normal	Normal Operation
2-3	Update	BMC in force update mode

Steps to perform the Force Integrated BMC Update:

1. Power down and remove the AC power cord.
2. Open the server chassis. See your server chassis documentation for instructions.
3. Move jumper from the default operating position, covering pins 1 and 2, to the enabled position, covering pins 2 and 3.
4. Close the server chassis.
5. Reconnect the AC cord and power up the server.
6. Perform the BMC firmware update procedure as documented in the ReleaseNote.TXT file included in the given BMC firmware update package. After successful completion of the firmware update process, the firmware update utility may generate an error stating the BMC is still in update mode.
7. Power down and remove the AC power cord.
8. Open the server chassis.
9. Move the jumper from the enabled position, covering pins 2 and 3 to the disabled position, covering pins 1 and 2.
10. Close the server chassis.



11. Reconnect the AC cord and power up the server.

---

**Note:** Normal BMC functionality is disabled with the Force BMC Update jumper is set to the enabled position. You should never run the server with the BMC Force Update jumper set in this position. You should only use this jumper setting when the standard firmware update process fails. This jumper should remain in the default/disabled position when the server is running normally.

---

The server board has several 3-pin jumper blocks that can be used to configure, protect, or recover specific features of the server board.

## 8.2 Force ME Update (J1E2)

When this 3-pin jumper is set, it manually puts the ME firmware in update mode, which enables the user to update ME firmware code when necessary.

**Table 54. Force ME Update Jumper**

Jumper Position	Mode of Operation	Note
1-2	Normal	Normal operation
2-3	Update	ME in force update mode

---

**Note:** Normal ME functionality is disabled with the Force ME Update jumper is set to the enabled position. You should never run the server with the ME Force Update jumper set in this position. You should only use this jumper setting when the standard firmware update process fails. This jumper should remain in the default/disabled position when the server is running normally.

---

Steps to perform the Force ME Update:

1. Power down and remove the AC power cord.
2. Open the server chassis. For instructions, see your server chassis documentation.
3. Move jumper from the default operating position (covering pins 1 and 2) to the enabled position (covering pins 2 and 3).
4. Close the server chassis.
5. Reconnect the AC cord and power up the server.
6. Perform the ME firmware update procedure as documented in the README.TXT file that is included in the given ME firmware update package (same package as BIOS).
7. Power down and remove the AC power cord.
8. Open the server chassis.
9. Move jumper from the enabled position (covering pins 2 and 3) to the disabled position (covering pins 1 and 2).
10. Close the server chassis.

### 8.3 Password Clear (J1E3)

This 3-pin jumper is used to clear the BIOS password.

**Table 55. BIOS Password Clear Jumper**

Jumper Position	Mode of Operation	Note
1-2	Normal	Normal mode. Password in protection
2-3	Clear Password	BIOS password is cleared

Steps to perform the password clear:

1. Power down server. Do not unplug the power cord.
2. Open the chassis. For instructions, refer to your server chassis documentation.
3. Move the jumper (J1F2) from the default operating position, covering pins 1 and 2, to the password clear position, covering pins 2 and 3.
4. Close the server chassis.
5. Power up the server, wait 10 seconds or until POST completes.
6. Power down the server.
7. Open the chassis and move the jumper back to default position, covering pins 1 and 2.
8. Close the server chassis.
9. Power up the server. The password is now cleared and you can reset it by going into the BIOS setup. The BIOS password is now cleared.

### 8.4 BIOS Recovery Mode (J1E1)

The Intel® Server Board S2600WP uses BIOS recovery to repair the system BIOS from flash corruption in the main BIOS and Boot Block. This 3-pin jumper is used to reload the BIOS when the image is suspected to be corrupted. For directions on how to recover the BIOS, refer to the specific BIOS release notes.

**Table 56. BIOS Recovery Mode Jumper**

Jumper Position	Mode of Operation	Note
1-2	Normal	Normal mode
2-3	Recovery	BIOS in recovery mode

You can accomplish a BIOS recovery from the SATA CD and USB Mass Storage device. Please note that this platform does not support recovery from a USB floppy.

The recovery media must contain the following files under the root directory:

1. RML.ROM
2. UEFI iFlash32 11.0 Build 2 (including iFlash32.efi and ipmi.efi)
3. \*Rec.CAP

#### 4. Startup.nsh (update accordingly to use proper \*Rec.CAP file)

The BIOS starts the recovery process by first loading and booting to the recovery image file (RML.ROM) on the root directory of the recovery media (USB disk). This process takes place before any video or console is available. Once the system boots to this recovery image file (FVMAIN.FV), it boots automatically into the EFI Shell to invoke the Startup.nsh script and start the flash update application (IFlash32.efi). IFlash32.efi requires the supporting BIOS Capsule image file (\*Rec.CAP).

After the update is complete, a message displays, stating the “BIOS has been updated successfully”. This indicates the recovery process is finished.

The user should then switch the recovery jumper back to normal operation and restart the system by performing a power cycle.

The following steps demonstrate this recovery process:

1. Power OFF the system.
2. Insert recovery media.
3. Switch the recovery jumper. Details regarding the jumper ID and location can be obtained from the Board EPS for that Platform.
4. Power ON the system.
5. The BIOS POST screen will appear displaying the progress, and the system automatically boots to the EFI SHELL.
6. The Startup.nsh file executes, and initiates the flash update (IFlash32.efi) with a new capsule file (\*Rec.CAP). The regular iFlash message displays at the end of the process—once the flash update succeeds.
7. Power OFF the system, and revert the recovery jumper position to "normal operation".
8. Power ON the system.
9. Do NOT interrupt the BIOS POST during the first boot.

## 8.5 Reset BIOS Settings (J1D5)

This jumper used to be the CMOS Clear jumper. The BIOS has moved CMOS data to the NVRAM region of the BIOS flash since the previous generation. The BIOS checks during boot to determine if the data in the NVRAM must be set to default.

**Table 57. Reset BIOS Jumper**

Jumper Position	Mode of Operation	Note
1-2	Normal	These pins should have a jumper in place for normal system operation. (Default)
2-3	Reset BIOS Configuration	If these pins 2-3 are connected with AC power plugged, the CMOS settings are cleared within five seconds. These pins should not be connected for normal operation.

Steps to reset the BIOS settings to default:

1. Power down server. Do not unplug the power cord.
2. Open the server chassis. For instructions, see your server chassis documentation.
3. Move jumper (J1D5) from the default operating position, covering pins 1 and 2, to the reset/clear position, covering pins 2 and 3.
4. Wait five seconds.
5. Remove AC power.
6. Move the jumper back to default position, covering pins 1 and 2.
7. Close the server chassis.
8. Power up the server.

The BIOS settings are now cleared and you can reset it by going into the BIOS setup.

---

**Note:** Removing AC Power before performing the BIOS settings Clear operation causes the system to automatically power up and immediately power down, after the procedure is followed and AC power is re-applied. If this happens, remove the AC power cord again, wait 30 seconds, and re-install the AC power cord. Power-up the system and proceed to the <F2> BIOS Setup Utility to reset the desired settings.

---

## 9. PCI Express Riser Card and Assembly

Each compute node in Intel® Server System H2000WP Family includes three PCI Express\* riser slots that accepts dedicated PCI Express\* x16 Gen3 Risers to support low profile add-in card and Intel® IO module. Only Riser Slot 1 and Riser Slot 2 are available for risers. Riser Slot 3 is hidden by bridge board. The PCI Express slot on riser also accommodates PCI Express x8, x4, and x1 adapters.

### 9.1 PCI Express Riser for Slot 1

#### 9.1.1 Overview of PCI-Express Riser

Riser slot 1 on baseboard provides standard PCI Express x16 Gen3 signals, together with specific power pins to support high-power Graphic/GPGPU add-in card.

**Note:** Riser Slot 1 on baseboard only supports Intel® 1U/2U Risers. It will cause damage to any PCI-E based add-in card, which is directly plugged into the Riser Slot 1 on baseboard.

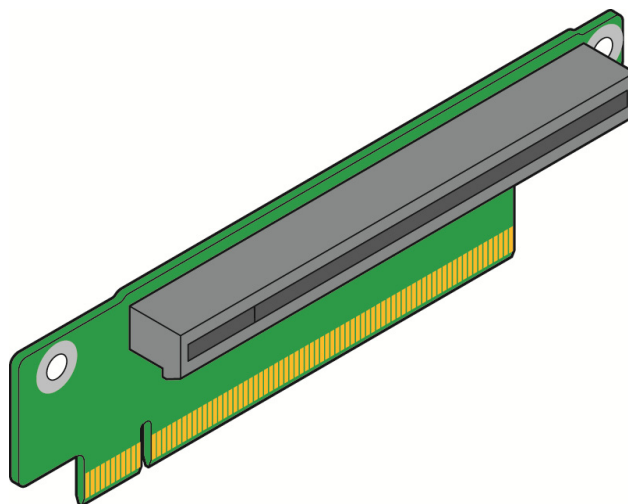

AF004224

Figure 36. PCI Express Riser for Riser Slot 1

#### 9.1.2 Pinout definition on Slot 1 Riser

Below is a list of pin definition on Slot 1 Riser.

Table 58. Riser Card Edge Pinout

Pin	Pin Name	Description	Pin	Pin Name	Description
B1	12V	20W 3.3V generated on riser	A1	12V	20W 3.3V generated on riser
B2	12V	66W for GPU	A2	12V	66W for GPU
B3	12V	66W for GPU	A3	12V	66W for GPU
B4	12V	66W for GPU	A4	SMDATA	

Pin	Pin Name	Description	Pin	Pin Name	Description
B5	SMCLK		A5	3.3VAUX	For wake on LAN
B6	3.3VAUX	For wake on LAN	A6	GPU_NODE_ON	can turn of 2U GPU power
B7	GND		A7	GPU_PWRGD	
B8	Tach9		A8	Tach11	
B9	Tach8		A9	Tach10	
B10	Tach7		A10	Tach6	
B11	Spare		A11	Spare	
<b>KEY</b>					
B12	Spare		A12	PWM2	GPU Fan speed control
B13	Spare		A13	GND	
B14	GND		A14	PERST#	
B15	SMBUS_R4 CLK		A15	WAKE#	
B16	SMBUS_R4 DAT		A16	GND	
B17	GND		A17	REFCLK+	Clock pair 1
B18	PETxP0	Tx Lane 0+	A18	REFCLK-	Clock pair 1
B19	PETxN0	Tx Lane 0-	A19	GND	
B20	GND		A20	PERxP0	Rx Lane 0+
B21	GND		A21	PERxN0	Rx Lane 0-
B22	PETxP1	Tx Lane 1+	A22	GND	
B23	PETxN1	Tx Lane 1-	A23	GND	
B24	GND		A24	PERxP1	Rx Lane 1+
B25	GND		A25	PERxN1	Rx Lane 1-
B26	PETxP2	Tx Lane 2+	A26	GND	
B27	PETxN2	Tx Lane 2-	A27	GND	
B28	GND		A28	PERxP2	Rx Lane 2+
B29	GND		A29	PERxN2	Rx Lane 2-
B30	PETxP3	Tx Lane 3+	A30	GND	
B31	PETxN3	Tx Lane 3-	A31	GND	
B32	GND		A32	PERxP3	Rx Lane 3+
B33	GND		A33	PERxN3	Rx Lane 3-
B34	PETxP4	Tx Lane 4+	A34	GND	
B35	PETxN4	Tx Lane 4-	A35	GND	
B36	GND		A36	PERxP4	Rx Lane 4+
B37	GND		A37	PERxN4	Rx Lane 4-
B38	PETxP5	Tx Lane 5+	A38	GND	
B39	PETxN5	Tx Lane 5-	A39	GND	
B40	GND		A40	PERxP5	Rx Lane 5+
B41	GND		A41	PERxN5	Rx Lane 5-
B42	PETxP6	Tx Lane 6+	A42	GND	
B43	PETxN6	Tx Lane 6-	A43	GND	
B44	GND		A44	PERxP6	Rx Lane 6+

Pin	Pin Name	Description	Pin	Pin Name	Description
B45	GND		A45	PERxN6	Rx Lane 6-
B46	PETxP7	Tx Lane 7+	A46	GND	
B47	PETxN7	Tx Lane 7-	A47	GND	
B48	GND		A48	PERxP7	Rx Lane 7+
B49	GND		A49	PERxN7	Rx Lane 7-
B50	PETxP8	Tx Lane 8+	A50	GND	
B51	PETxN8	Tx Lane 8-	A51	GND	
B52	GND		A52	PERxP8	Rx Lane 8+
B53	GND		A53	PERxN8	Rx Lane 8-
B54	PETxP9	Tx Lane 9+	A54	GND	
B55	PETxN9	Tx Lane 9-	A55	GND	
B56	GND		A56	PERxP9	Rx Lane 9+
B57	GND		A57	PERxN9	Rx Lane 9-
B58	PETxP10	Tx Lane 10+	A58	GND	
B59	PETxN10	Tx Lane 10-	A59	GND	
B60	GND		A60	PERxP10	Rx Lane 10+
B61	GND		A61	PERxN10	Rx Lane 10-
B62	PETxP11	Tx Lane 11+	A62	GND	
B63	PETxN11	Tx Lane 11-	A63	GND	
B64	GND		A64	PERxP11	Rx Lane 11+
B65	GND		A65	PERxN11	Rx Lane 11-
B66	PETxP12	Tx Lane 12+	A66	GND	
B67	PETxN12	Tx Lane 12-	A67	GND	
B68	GND		A68	PERxP12	Rx Lane 12+
B69	GND		A69	PERxN12	Rx Lane 12-
B70	PETxP13	Tx Lane 13+	A70	GND	
B71	PETxN13	Tx Lane 13-	A71	GND	
B72	GND		A72	PERxP13	Rx Lane 13+
B73	GND		A73	PERxN13	Rx Lane 13-
B74	PETxP14	Tx Lane 14+	A74	GND	
B75	PETxN14	Tx Lane 14-	A75	GND	
B76	GND		A76	PERxP14	Rx Lane 14+
B77	REFCLK+	Clock pair 2	A77	PERxN14	Rx Lane 14-
B78	REFCLK-	Clock pair 2	A78	GND	
B79	GND		A79	PERxP15	Rx Lane 15+
B80	PETxP15	Tx Lane 15+	A80	PERxN15	Rx Lane 15-
B81	PETxN15	Tx Lane 15-	A81	GND	
B82	GND		A82	Riser ID	Fix to High: PCIe x16

There is a standard PCI Express Gen3 x16 slot on riser card for PCIe based add-in card. The pin definitions for the slot are as below:

**Table 59. PCI Express Slot Pinout on Riser Card**

Pin-Side B	PCI Spec Signal	Pin-Side A	PCI Spec Signal
82	RSVD	82	GND
81	PRSNT2#	81	HSIN15
80	GND	80	HSIP15
79	HSO15	79	GND
78	HSOP15	78	GND
77	GND	77	HSIN14
76	GND	76	HSIP14
75	HSO14	75	GND
74	HSOP14	74	GND
73	GND	73	HSIN13
72	GND	72	HSIP13
71	HSO13	71	GND
70	HSOP13	70	GND
69	GND	69	HSIN12
68	GND	68	HSIP12
67	HSO12	67	GND
66	HSOP12	66	GND
65	GND	65	HSIN11
64	GND	64	HSIP11
63	HSO11	63	GND
62	HSOP11	62	GND
61	GND	61	HSIN10
60	GND	60	HSIP10
59	HSO10	59	GND
58	HSOP10	58	GND
57	GND	57	HSIN9
56	GND	56	HSIP9
55	HSO9	55	GND
54	HSOP9	54	GND
53	GND	53	HSIN8
52	GND	52	HSIP8
51	HSO8	51	GND
50	HSOP8	50	RSVD
49	GND	49	GND
48	PRSNT2#	48	HSIN7
47	GND	47	HSIP7
46	HSO7	46	GND
45	HSOP7	45	GND
44	GND	44	HSIN6
43	GND	43	HSIP6



Pin-Side B	PCI Spec Signal	Pin-Side A	PCI Spec Signal
42	HSO6	42	GND
41	HSOP6	41	GND
40	GND	40	HSIN5
39	GND	39	HSIP5
38	HSO5	38	GND
37	HSOP5	37	GND
36	GND	36	HSIN4
35	GND	35	HSIP4
34	HSO4	34	GND
33	HSOP4	33	RSVD
32	GND	32	RSVD
31	PRSNT2#	31	GND
30	RSVD	30	HSIN3
29	GND	29	HSIP3
28	HSO3	28	GND
27	HSOP3	27	GND
26	GND	26	HSIN2
25	GND	25	HSIP2
24	HSO2	24	GND
23	HSOP2	23	GND
22	GND	22	HSIN1
21	GND	21	HSIP1
20	HSO1	20	GND
19	HSOP1	19	RSVD
18	GND	18	GND
17	PRSNT2#	17	HSIN0
16	GND	16	HSIP0
15	HSO0	15	GND
14	HSOP0	14	REFCLK-
13	GND	13	REFCLK+
12	RSVD	12	GND
KEY		KEY	
KEY		KEY	
11	WAKE#	11	PWRGD
10	3.3V AUX	10	3.3V
9	JTAG1	9	3.3V
8	3.3V	8	JTAG5
7	GND	7	JTAG4
6	SMDAT	6	JTAG3
5	SMCLK	5	JTAG2
4	GND	4	GND
3	RSVD	3	12V
2	12V	2	12V
1	12V	1	PRSNT1#

## 9.2 PCI Express Riser with IOM Carrier for Slot 2 (Optional)

### 9.2.1 Overview of PCI-E Riser with IOM Carrier

The Riser with IOM carrier is provided as accessory to the server system. It is combined with below functions:

- Provide PCI Express x8 Gen 3 signals from riser
- Integrated 1GbE management port for Intel® Remote Management Module 4
- Support PCI-E x4 based Intel® IO Module

Riser slot 2 on baseboard provides standard PCI Express x16 Gen3 signals, together with specific power pins to support high-power Graphic/GPGPU add-in card.

---

**Note:** Riser Slot 2 on baseboard only supports Intel® 1U/2U Risers. It will cause damage to any PCI-E based add-in card, which is directly plugged into the Riser Slot 1.

---

The PCI-E slot on Riser is x16 mechanically with x8 electrically. The IOM carrier is using PCI-E x8 card edge with PCI-E x4 IO module slot.

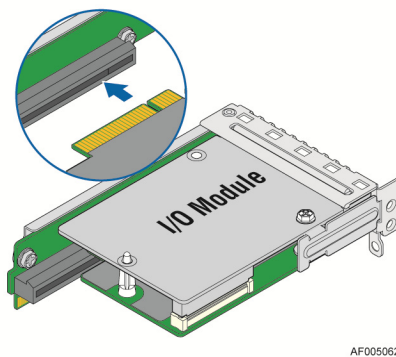

Figure 37. PCI Express Riser with bracket for Riser Slot 2

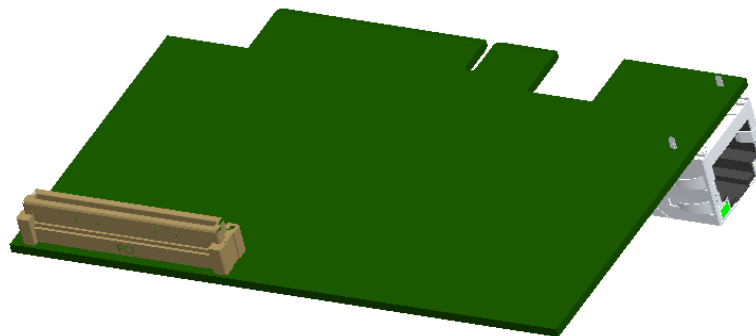

Figure 38. IOM Carrier

The 1GbE port is dedicated NIC port for RMM4 Lite module. It only works once the RMM4 Lite module is installed in the system. The LED of dedicated NIC port is following the below definition:

**Table 60. Dedicated NIC Port LED Functionality**

LED	Color	Condition	Functionality
Dedicated NIC Speed	Green	On	1Gbps mode
	Amber	On	100Mbps mode
		Off	10Mbps mode
Dedicated NIC Activity	Green	On	LAN link and no access
	Green	Blink	LAN access
		Off	Idle

### 9.2.2 Pinout definition on Slot 2 Riser and IOM Carrier

Below is a list of pin definition for Slot 2 Riser and IOM Carrier.

**Table 61. Riser Card Edge Pinout**

Side Even	Signal		Side Odd	Signal	
200	12V	20W 3.3V generated on riser	199	12V	For IOM
198	12V	66W for GPU	197	12V	66W for GPU
196	12V	66W for GPU	195	spare	
194	spare		193	spare	
192	spare		191	GND	
190	spare		189	SMDATA	For rIOM temp sensor
188	GND		187	5VAUX	For DNM and IOM wake on LAN
186	SMCLK	For rIOM temp sensor	185	PRESENT#	rIOM function present
184	3.3V Aux	For DNM and IOM wake on LAN	183	RIOM_ACT#	
182	GND		181	RXD_3	RGMII receive data
180	TXD_0	RGMII txmit data	179	RXD_2	RGMII receive data
178	TXD_1	RGMII txmit data	177	RXD_1	RGMII receive data
176	TXD_2	RGMII txmit data	175	RXD_0	RGMII receive data
174	TXD_3	RGMII txmit data	173	GND	
172	GND		171	RX_CTL	RGMII receive Cntrl
170	TX_CLK	RGMII txmit Clock	169	GND	
168	TX_CTL	RGMII txmit Cntrl	167	RX_CLK	RGMII receive Clock
166	MDIO		165	MDC	
164	spare		163	GND	
162	GND		161	IB_CLK3+	
160	PERST#		159	IB_CLK3-	
158	WAKE#		157	GND	
156	GND		155	CLK1+	
154	CLK2+		153	CLK1-	
152	CLK2-		151	GND	
150	GND		149	R00+	

Side Even	Signal		Side Odd	Signal	
148	T00+		147	R00-	
146	T00-		145	GND	
144	GND		143	R01+	
142	T01+		141	R01-	
140	T01-		139	GND	
138	GND		137	R02+	
136	T02+		135	R02-	
134	T02-		133	GND	
132	GND		131	R03+	
130	T03+		129	R03-	
128	T03-		127	GND	
126	GND		125	R04+	
124	T04+		123	R04-	
122	T04-		121	GND	
120	GND		119	R05+	
118	T05+		117	R05-	
116	T05-		115	GND	
114	GND		113	R06+	
112	T06+		111	R06-	
110	T06-		109	GND	
108	GND		107	R07+	
106	T07+		105	R07-	
104	T07-		103	GND	
102	GND		101	IB_R00+	
100	IB_T00+		99	IB_R00-	
98	IB_T00-		97	GND	
96	GND		95	IB_R01+	
94	IB_T01+		93	IB_R01-	
92	IB_T01-		91	GND	
90	GND		89	IB_R02+	
88	IB_T02+		87	IB_R02-	
86	IB_T02-		85	GND	
84	GND		83	IB_R03+	
82	IB_T03+		81	IB_R03-	
80	IB_T03-		79	GND	
78	GND		77	IB_R04+	
76	IB_T04+		75	IB_R04-	
74	IB_T04-		73	GND	
72	GND		71	IB_R05+	
70	IB_T05+		69	IB_R05-	
68	IB_T05-		67	GND	
66	GND		65	GND	
64	GND		63	GND	
62	GND		61	IB_R06+	
60	IB_T06+		59	IB_R06-	
58	IB_T06-		57	GND	

Side Even	Signal		Side Odd	Signal	
56	GND		55	IB_R07+	
54	IB_T07+		53	IB_R07-	
52	IB_T07-		51	GND	
50	GND		49	R08+	
48	T08+		47	R08-	
46	T08-		45	GND	
44	GND		43	R09+	
42	T09+		41	R09-	
40	T09-		39	GND	
38	GND		37	R10+	
36	T10+		35	R10-	
34	T10-		33	GND	
32	GND		31	R11+	
30	T11+		29	R11-	
28	T11-		27	GND	
26	GND		25	R12+	
24	T12+		23	R12-	
22	T12-		21	GND	
20	GND		19	R13+	
18	T13+		17	R13-	
16	T13-		15	GND	
14	GND		13	R14+	
12	T14+		11	R14-	
10	T14-		9	GND	
8	GND		7	R15+	
6	T15+		5	R15-	
4	T15-		3	GND	
2	GND		1	Riser ID	Riser ID

**Table 62 PCI Express Slot Pinout on Riser Card**

Pin-Side B	PCI Spec Signal	Pin-Side A	PCI Spec Signal
82	RSVD	82	GND
81	PRSNT2#	81	HSIN15
80	GND	80	HSIP15
79	HSO15	79	GND
78	HSOP15	78	GND
77	GND	77	HSIN14
76	GND	76	HSIP14
75	HSO14	75	GND
74	HSOP14	74	GND
73	GND	73	HSIN13
72	GND	72	HSIP13
71	HSO13	71	GND
70	HSOP13	70	GND
69	GND	69	HSIN12

Pin-Side B	PCI Spec Signal	Pin-Side A	PCI Spec Signal
68	GND	68	HSIP12
67	HSO12	67	GND
66	HSOP12	66	GND
65	GND	65	HSIN11
64	GND	64	HSIP11
63	HSO11	63	GND
62	HSOP11	62	GND
61	GND	61	HSIN10
60	GND	60	HSIP10
59	HSO10	59	GND
58	HSOP10	58	GND
57	GND	57	HSIN9
56	GND	56	HSIP9
55	HSO9	55	GND
54	HSOP9	54	GND
53	GND	53	HSIN8
52	GND	52	HSIP8
51	HSO8	51	GND
50	HSOP8	50	RSVD
49	GND	49	GND
48	PRSNT2#	48	HSIN7
47	GND	47	HSIP7
46	HSO7	46	GND
45	HSOP7	45	GND
44	GND	44	HSIN6
43	GND	43	HSIP6
42	HSO6	42	GND
41	HSOP6	41	GND
40	GND	40	HSIN5
39	GND	39	HSIP5
38	HSO5	38	GND
37	HSOP5	37	GND
36	GND	36	HSIN4
35	GND	35	HSIP4
34	HSO4	34	GND
33	HSOP4	33	RSVD
32	GND	32	RSVD
31	PRSNT2#	31	GND
30	RSVD	30	HSIN3
29	GND	29	HSIP3
28	HSO3	28	GND
27	HSOP3	27	GND
26	GND	26	HSIN2
25	GND	25	HSIP2
24	HSO2	24	GND

Pin-Side B	PCI Spec Signal	Pin-Side A	PCI Spec Signal
23	HSOP2	23	GND
22	GND	22	HSIN1
21	GND	21	HSIP1
20	HSO1	20	GND
19	HSOP1	19	RSVD
18	GND	18	GND
17	PRSNT2#	17	HSIN0
16	GND	16	HSIP0
15	HSO0	15	GND
14	HSOP0	14	REFCLK-
13	GND	13	REFCLK+
12	RSVD	12	GND
KEY		KEY	
KEY		KEY	
11	WAKE#	11	PWRGD
10	3.3V AUX	10	3.3V
9	JTAG1	9	3.3V
8	3.3V	8	JTAG5
7	GND	7	JTAG4
6	SMDAT	6	JTAG3
5	SMCLK	5	JTAG2
4	GND	4	GND
3	RSVD	3	12V
2	12V	2	12V
1	12V	1	PRSNT1#

**Table 63. IO Module Slot on Carrier**

Pin	Signal	Pin	Signal
1	3.3V	2	12V
3	3.3V	4	12V
5	3.3V	6	12V
7	3.3V	8	12V
9	RSVD	10	FRU/TEMP ADDR [I]
11	GND	12	5VSB
13	RSVD+	14	FM_IO_MODULE_EN
15	RSVD-	16	3.3VSTBY
17	GND	18	LED_GLOBAL ACT#
19	RSVD	20	FM_IOM_PRESENT_N
21	RSVD	22	WAKE#
23	GND	24	PERST#
25	SMB CLK	26	GND
27	SMB DAT	28	rIOM REFCLK+ [0]

Pin	Signal	Pin	Signal
29	GND	30	rIOM REFCLK- [0]
31	PCIe Gen3 Tn [7]	32	GND
33	PCIe Gen3 Tp [7]	34	PCIe Gen3 Rn [7]
35	GND	36	PCIe Gen3 Rp [7]
37	PCIe Gen3 Tn [6]	38	GND
39	PCIe Gen3 Tp [6]	40	PCIe Gen3 Rn [6]
41	GND	42	PCIe Gen3 Rp [6]
43	PCIe Gen3 Tn [5]	44	GND
45	PCIe Gen3 Tp [5]	46	PCIe Gen3 Rn [5]
47	GND	48	PCIe Gen3 Rp [5]
49	PCIe Gen3 Tn [4]	50	GND
51	PCIe Gen3 Tp [4]	52	PCIe Gen3 Rn [4]
53	GND	54	PCIe Gen3 Rp [4]
55	PCIe Gen3 Tn [3]	56	GND
57	PCIe Gen3 Tp [3]	58	PCIe Gen3 Rn [3]
59	GND	60	PCIe Gen3 Rp [3]
61	PCIe Gen3 Tn [2]	62	GND
63	PCIe Gen3 Tp [2]	64	PCIe Gen3 Rn [2]
65	GND	66	PCIe Gen3 Rp [2]
67	PCIe Gen3 Tn [1]	68	GND
69	PCIe Gen3 Tp [1]	70	PCIe Gen3 Rn [1]
71	GND	72	PCIe Gen3 Rp [1]
73	PCIe Gen3 Tn [0]	74	GND
75	PCIe Gen3 Tp [0]	76	PCIe Gen3 Rn [0]
77	GND	78	PCIe Gen3 Rp [0]
79	RSVD	80	GND



## Appendix A: Integration and Usage Tips

Before attempting to integrate and configure your system, you should reference this section, which provides a list of useful information.

- After the system is integrated with processors, memory, and peripheral devices, the FRUSDR utility **must** be run to load the proper Sensor Data Record data to the integrated Server Management subsystem. Failure to run this utility may prevent Server Management from accurately monitoring system health and may affect system performance. The FRUSDR utility for this server system can either be run from the Intel Deployment CDROM that came with your system, or can be downloaded from the Intel website referenced at the bottom of this page.
- To ensure the highest system reliability, make sure the latest system software is loaded on the server before deploying the system onto a live networking environment. This includes system BIOS, FRUSDR, BMC firmware, and hot-swap controller firmware. The system software can be updated using the Intel Deployment CDROM that came with your system or can be downloaded from the Intel website referenced at the bottom of this page.
- System fans are not hot-swappable.
- Only supported memory validated by Intel should be used in this server system. A list of supported memory can be found in the Intel® Server Board S2600WP Tested Memory List which can be downloaded from the Intel website referenced at the bottom of this page.
- This system supports the Intel® Xeon® processor E5-2600 sequence. You cannot use Intel® Xeon® processors not referenced on the supported processor list in this server system.
- You must use the CPU/memory air duct to maintain system thermals.
- To maintain system thermals, you must populate all hard drive bays with either a hard drive or drive blank.
- You must remove AC power from the system prior to opening the chassis for service

You can download the latest system documentation, drivers, and system software from the Intel Support website at

[http://www.intel.com/p/en\\_US/support/highlights/server/H2000WP](http://www.intel.com/p/en_US/support/highlights/server/H2000WP)

## Appendix B: POST Code LED Decoder

During the system boot process, the BIOS executes a number of platform configuration processes, each of which is assigned a specific hex POST code number. As each configuration routine is started, the BIOS displays the POST code to the POST Code Diagnostic LEDs on the back edge of the server board. To assist in troubleshooting a system hang during the POST process, you can use the diagnostic LEDs to identify the last POST process executed.

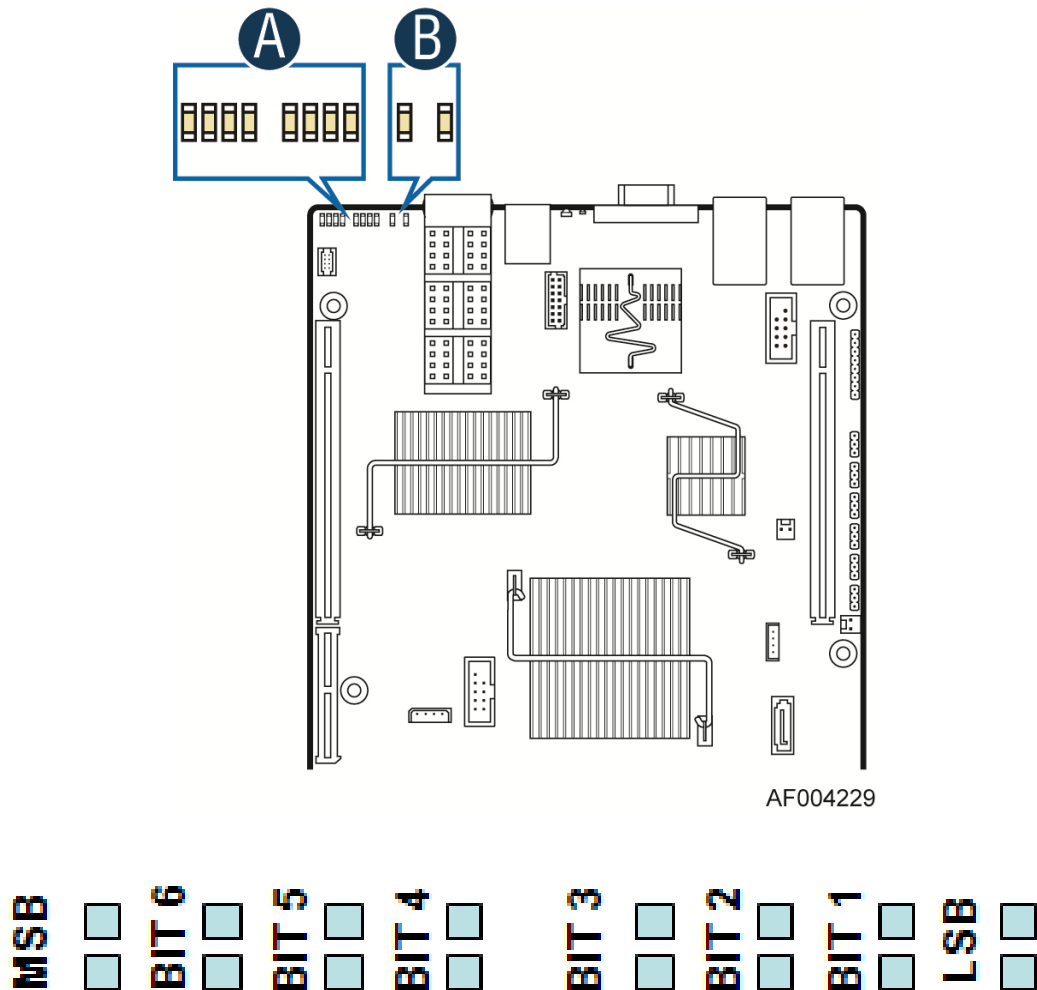

**Figure 39. Diagnostic LED location**

**Table 64. POST Code Diagnostic LED Location**

<b>A</b>	ID LED	<b>B</b>	Status LED
<b>C</b>	Diagnostic LED #7 MSB	<b>G</b>	Diagnostic LED #3
<b>D</b>	Diagnostic LED #6	<b>H</b>	Diagnostic LED #2
<b>E</b>	Diagnostic LED #5	<b>I</b>	Diagnostic LED #1
<b>F</b>	Diagnostic LED #4	<b>J</b>	Diagnostic LED #0 LSB

Each POST code is represented by the eight amber diagnostic LEDs. The POST codes are divided into two nibbles, an upper nibble and a lower nibble. The upper nibble bits are represented by diagnostic LEDs #4, #5, #6, and #7. The lower nibble bits are represented by diagnostics LEDs #0, #1, #2, and #3. If the bit is set in the upper and lower nibbles, then the corresponding LED is lit. If the bit is clear, then the corresponding LED is off.

The diagnostic LED #7 is labeled as “MSB” (Most Significant Bit), and the diagnostic LED #0 is labeled as “LSB” (Least Significant Bit).

In the following example, the BIOS sends a value of ACh to the diagnostic LED decoder. The LEDs are decoded as follows:

**Table 65. POST Progress Code LED Example**

LEDs	Upper Nibble LEDs				Lower Nibble LEDs			
	MSB							LSB
	LED #7	LED #6	LED #5	LED #4	LED #3	LED #2	LED #1	LED #0
	8h	4h	2h	1h	8h	4h	2h	1h
<b>Status</b>	ON	OFF	ON	OFF	ON	ON	OFF	OFF
<b>Results</b>	1	0	1	0	1	1	0	0
	<b>Ah</b>				<b>Ch</b>			

Upper nibble bits = 1010b = Ah; Lower nibble bits = 1100b = Ch; the two are concatenated as ACh.

**Table 66. Diagnostic LED POST Code Decoder**

Checkpoint	Diagnostic LED Decoder								Description
	O = On, X=Off								
	Upper Nibble				Lower Nibble				
	MSB							LSB	
LED	#7	#6	#5	#4	#3	#2	#1	#0	
<b>Host Processor</b>									
0x04h	X	X	X	X	X	O	X	X	Early processor initialization (flat32.asm) where system BSP is selected
0x10h	X	X	X	O	X	X	X	X	Power-on initialization of the host processor (Boot Strap Processor)
0x11h	X	X	X	O	X	X	X	O	Host processor cache initialization (including AP)
0x12h	X	X	X	O	X	X	O	X	Starting application processor initialization
0x13h	X	X	X	O	X	X	O	O	SMM initialization
<b>Chipset</b>									
0x21h	X	X	O	X	X	X	X	O	Initializing a chipset component
<b>Memory</b>									
0x22h	X	X	O	X	X	X	O	X	Reading configuration data from memory (SPD on FBDIMM)
0x23h	X	X	O	X	X	X	O	O	Detecting presence of memory
0x24h	X	X	O	X	X	O	X	X	Programming timing parameters in the memory controller
0x25h	X	X	O	X	X	O	X	O	Configuring memory parameters in the memory controller
0x26h	X	X	O	X	X	O	O	X	Optimizing memory controller settings
0x27h	X	X	O	X	X	O	O	O	Initializing memory, such as ECC in it
0x28h	X	X	O	X	O	X	X	X	Testing memory
<b>PCI Bus</b>									
0x50h	X	O	X	O	X	X	X	X	Enumerating PCI buses
0x51h	X	O	X	O	X	X	X	O	Allocating resources to PCI buses
0x52h	X	O	X	O	X	X	O	X	Hot Plug PCI controller initialization

Checkpoint	Diagnostic LED Decoder								Description
	O = On, X=Off								
	Upper Nibble				Lower Nibble				
	MSB							LSB	
LED	8h	4h	2h	1h	8h	4h	2h	1h	#0
0x53h	X	O	X	O	X	X	O	O	Reserved for PCI bus
0x54h	X	O	X	O	X	O	X	X	Reserved for PCI bus
0x55h	X	O	X	O	X	O	X	O	Reserved for PCI bus
0x56h	X	O	X	O	X	O	O	X	Reserved for PCI bus
0x57h	X	O	X	O	X	O	O	O	Reserved for PCI bus
USB									
0x58h	X	O	X	O	O	X	X	X	Resetting USB bus
0x59h	X	O	X	O	O	X	X	O	Reserved for USB devices
ATA/ATAPI/SATA									
0x5Ah	X	O	X	O	O	X	O	X	Resetting SATA bus and all devices
0x5Bh	X	O	X	O	O	X	O	O	Detecting the presence of ATA device
0x5Ch	X	O	X	O	O	O	X	X	Enable SMART if supported by ATA device
0x5Dh	X	O	X	O	O	O	X	O	Reserved for ATA
SMBUS									
0x5Eh	X	O	X	O	O	O	O	X	Resetting SMBUS
0x5Fh	X	O	X	O	O	O	O	O	Reserved for SMBUS
Local Console									
0x70h	X	O	O	O	X	X	X	X	Resetting the video controller (VGA)
0x71h	X	O	O	O	X	X	X	O	Disabling the video controller (VGA)
0x72h	X	O	O	O	X	X	O	X	Enabling the video controller (VGA)
Remote Console									
0x78h	X	O	O	O	O	X	X	X	Resetting the console controller
0x79h	X	O	O	O	O	X	X	O	Disabling the console controller
0x7Ah	X	O	O	O	O	X	O	X	Enabling the console controller
Keyboard (only USB)									
0x90h	O	X	X	O	X	X	X	X	Resetting the keyboard
0x91h	O	X	X	O	X	X	X	O	Disabling the keyboard
0x92h	O	X	X	O	X	X	O	X	Detecting the presence of the keyboard
0x93h	O	X	X	O	X	X	O	O	Enabling the keyboard
0x94h	O	X	X	O	X	O	X	X	Clearing keyboard input buffer
0x95h	O	X	X	O	X	O	X	O	Reserved for keyboard
Mouse (only USB)									
0x98h	O	X	X	O	X	X	O	X	Resetting the mouse
0x99h	O	X	X	O	X	X	O	O	Detecting the mouse
0x9Ah	O	X	X	O	X	O	O	X	Detecting the presence of mouse
0x9Bh	O	X	X	O	X	O	O	O	Enabling the mouse
Fixed Media									
0xB0h	O	X	O	O	X	X	X	X	Resetting fixed media device
0xB1h	O	X	O	O	X	X	X	O	Disabling fixed media device
0xB2h	O	X	O	O	X	X	O	X	Detecting presence of a fixed media device (SATA hard drive detection, etc.)
0xB3h	O	X	O	O	X	X	O	O	Enabling/configuring a fixed media device
Removable Media									
0xB8h	O	X	O	O	O	X	X	X	Resetting removable media device
0xB9h	O	X	O	O	O	X	X	O	Disabling removable media device

Checkpoint	Diagnostic LED Decoder								Description
	O = On, X=Off								
	Upper Nibble				Lower Nibble				
	MSB							LSB	
LED	8h	4h	2h	1h	8h	4h	2h	1h	#0
0xBAh	O	X	O	O	O	X	O	X	Detecting presence of a removable media device (SATA CDROM detection, etc.)
0xBCh	O	X	O	O	O	O	X	X	Enabling/configuring a removable media device
Boot Device Selection (BDS)									
0xD0	O	O	X	O	X	X	X	X	Entered the Boot Device Selection phase (BDS)
0xD1	O	O	X	O	X	X	X	O	Return to last good boot device
0xD2	O	O	X	O	X	X	O	X	Setup boot device selection policy
0xD3	O	O	X	O	X	X	O	O	Connect boot device controller
0xD4	O	O	X	O	X	O	X	X	Attempt flash update boot mode
0xD5	O	O	X	O	X	O	X	O	Transfer control to EFI boot
0xD6	O	O	X	O	X	O	O	X	Trying to boot device selection
0xDF	O	O	X	O	O	O	O	O	Reserved for boot device selection
Pre-EFI Initialization (PEI) Core									
0xE0h	O	O	O	X	X	X	X	X	Entered Pre-EFI Initialization phase (PEI)
0xE1h	O	O	O	X	X	X	X	O	Started dispatching early initialization modules (PEIM)
0xE2h	O	O	O	X	X	X	O	X	Initial memory found, configured, and installed correctly
0xE3h	O	O	O	X	X	X	O	O	Transfer control to the DXE Core
Driver eXecution Environment (DXE) Core									
0xE4h	O	O	O	X	X	O	X	X	Entered EFI driver execution phase (DXE)
0xE5h	O	O	O	X	X	O	X	O	Started dispatching drivers
0xE6h	O	O	O	X	X	O	O	X	Started connecting drivers
DXE Drivers									
0xE7h	O	O	O	X	O	O	X	O	Waiting for user input
0xE8h	O	O	O	X	O	X	X	X	Checking password
0xE9h	O	O	O	X	O	X	X	O	Entering BIOS setup
0xEAh	O	O	O	X	O	O	X	X	Flash Update
0xEEh	O	O	O	X	O	O	X	X	Calling Int 19. One beep unless silent boot is enabled.
0xEFh	O	O	O	X	O	O	X	O	Unrecoverable boot failure
Pre-EFI Initialization Module (PEIM)/Recovery									
0x30h	X	X	O	O	X	X	X	X	Crisis recovery has been initiated because of a user request
0x31h	X	X	O	O	X	X	X	O	Crisis recovery has been initiated by software (corrupt flash)
0x34h	X	X	O	O	X	O	X	X	Loading crisis recovery capsule
0x35h	X	X	O	O	X	O	X	O	Handing off control to the crisis recovery capsule
0x3Fh	X	X	O	O	O	O	O	O	Crisis recovery capsule failed integrity check of capsule descriptors
Runtime Phase/EFI Operating System Boot									
0XF2h	O	O	O	O	X	X	O	X	Signal that the OS has switched to virtual memory mode
0XF4h	O	O	O	O	X	O	X	X	Entering the sleep state
0XF5h	O	O	O	O	X	O	X	O	Exiting the sleep state
0XF8h	O	O	O	O	O	X	X	X	Operating system has requested EFI to close boot services has been cancelled.
Progress Code									
0XF9h	O	X	X	O	X	X	X	X	Resetting the keyboard
0xFAh	O	X	X	O	X	X	X	O	Disabling the keyboard

## Appendix C: Video POST Code Errors

Whenever possible, the BIOS outputs the current boot progress codes on the video screen. Progress codes are 32-bit quantities plus optional data. The 32-bit numbers include class, subclass, and operation information. The class and subclass fields point to the type of hardware being initialized. The operation field represents the specific initialization activity. Based on the data bit availability to display progress codes, a progress code can be customized to fit the data width. The higher the data bit, the higher the granularity of information that can be sent on the progress port. The progress codes may be reported by the system BIOS or option ROMs.

The Response section in the following table is divided into three types:

- **No Pause:** The message is displayed on the local Video screen during POST or in the Error Manager. The system continues booting with a degraded state. The user may want to replace the erroneous unit. The setup POST error Pause setting does not have any effect with this error.
- **Pause:** The message is displayed on the Error Manager screen, and an error is logged to the SEL. The setup POST error Pause setting determines whether the system pauses to the Error Manager for this type of error, where the user can take immediate corrective action or choose to continue booting.
- **Halt:** The message is displayed on the Error Manager screen, an error is logged to the SEL, and the system cannot boot unless the error is resolved. The user needs to replace the faulty part and restart the system. The setup POST error Pause setting does not have any effect with this error.

**Table 67. POST Error Message and Handling**

Error Code	Error Message	Response
0012	CMOS date/time not set.	Pause
0048	Password check failed.	Halt
0108	Keyboard component encountered a locked error.	No Pause
0109	Keyboard component encountered a stuck key error.	No Pause
0113	Fixed Media The SAS RAID firmware cannot run properly. The user should attempt to re-flash the firmware.	Pause
0140	PCI component encountered a PERR error.	Pause
0141	PCI resource conflict.	Pause
0146	PCI out of resources error.	Pause
0192	L3 cache size mismatch.	Halt
0194	CPUID, processor families are different.	Halt
0195	Front side bus mismatch.	Pause
0196	Processor model mismatch.	Pause
0197	Processor speed mismatch.	Pause
0198	Processor family is unsupported.	Pause
019F	Processor and chipset stepping configuration is unsupported.	Pause
5220	CMOS/NVRAM configuration cleared.	Pause
5221	Password cleared by jumper.	Pause
5224	Password clear jumper is set.	Pause
8110	Processor 01 internal error (IERR) on last boot.	Pause
8111	Processor 02 internal error (IERR) on last boot.	Pause
8120	Processor 01 thermal trip error on last boot.	Pause
8121	Processor 02 thermal trip error on last boot.	Pause
8130	Processor 01 disabled.	Pause
8131	Processor 02 disabled.	Pause

Error Code	Error Message	Response
8140	Processor 01 Failed FRB-3 Timer.	No Pause
8141	Processor 02 Failed FRB-3 Timer..	No Pause
8160	Processor 01 unable to apply BIOS update.	Pause
8161	Processor 02 unable to apply BIOS update.	Pause
8170	Processor 01 failed Self Test (BIST).	Pause
8171	Processor 02 failed Self Test (BIST).	Pause
8180	Processor 01 BIOS does not support the current stepping for processor.	No Pause
8181	Processor 02 BIOS does not support the current stepping for processor.	No Pause
8190	Watchdog timer failed on last boot.	Pause
8198	Operating system boot watchdog timer expired on last boot.	Pause
8300	Integrated Baseboard Management Controller failed Self Test.	Pause
84F2	Integrated Baseboard Management Controller failed to respond.	Pause
84F3	Integrated Baseboard Management Controller in update mode.	Pause
84F4	Sensor data record empty.	Pause
84FF	System event log full.	No Pause
8500	Memory component could not be configured in the selected RAS mode.	Pause
8520	DIMM_A1 failed Self Test (BIST).	Pause
8521	DIMM_A2 failed Self Test (BIST).	Pause
8522	DIMM_A3 failed Self Test (BIST).	Pause
8523	DIMM_A4 failed Self Test (BIST).	Pause
8524	DIMM_B1 failed Self Test (BIST).	Pause
8525	DIMM_B2 failed Self Test (BIST).	Pause
8526	DIMM_B3 failed Self Test (BIST).	Pause
8527	DIMM_B4 failed Self Test (BIST).	Pause
8528	DIMM_C1 failed Self Test (BIST).	Pause
8529	DIMM_C2 failed Self Test (BIST).	Pause
852A	DIMM_C3 failed Self Test (BIST).	Pause
852B	DIMM_C4 failed Self Test (BIST).	Pause
852C	DIMM_D1 failed Self Test (BIST).	Pause
852D	DIMM_D2 failed Self Test (BIST).	Pause
852E	DIMM_D3 failed Self Test (BIST).	Pause
852F	DIMM_D4 failed Self Test (BIST).	Pause
8540	DIMM_A1 Disabled.	Pause
8541	DIMM_A2 Disabled.	Pause
8542	DIMM_A3 Disabled.	Pause
8543	DIMM_A4 Disabled.	Pause
8544	DIMM_B1 Disabled.	Pause
8545	DIMM_B2 Disabled.	Pause
8546	DIMM_B3 Disabled.	Pause
8547	DIMM_B4 Disabled.	Pause
8548	DIMM_C1 Disabled.	Pause
8549	DIMM_C2 Disabled.	Pause
854A	DIMM_C3 Disabled.	Pause
854B	DIMM_C4 Disabled.	Pause
854C	DIMM_D1 Disabled.	Pause
854D	DIMM_D2 Disabled.	Pause
854E	DIMM_D3 Disabled.	Pause
854F	DIMM_D4 Disabled.	Pause
8560	DIMM_A1 Component encountered a Serial Presence Detection (SPD) fail error.	Pause
8561	DIMM_A2 Component encountered a Serial Presence Detection (SPD) fail error.	Pause
8562	DIMM_A3 Component encountered a Serial Presence Detection (SPD) fail error.	Pause
8563	DIMM_A4 Component encountered a Serial Presence Detection (SPD) fail error.	Pause
8564	DIMM_B1 Component encountered a Serial Presence Detection (SPD) fail error.	Pause
8565	DIMM_B2 Component encountered a Serial Presence Detection (SPD) fail error.	Pause
8566	DIMM_B3 Component encountered a Serial Presence Detection (SPD) fail error.	Pause
8567	DIMM_B4 Component encountered a Serial Presence Detection (SPD) fail error.	Pause
8568	DIMM_C1 Component encountered a Serial Presence Detection (SPD) fail error.	Pause

Error Code	Error Message	Response
8569	DIMM_C2 Component encountered a Serial Presence Detection (SPD) fail error.	Pause
856A	DIMM_C3 Component encountered a Serial Presence Detection (SPD) fail error.	Pause
856B	DIMM_C4 Component encountered a Serial Presence Detection (SPD) fail error.	Pause
856C	DIMM_D1 Component encountered a Serial Presence Detection (SPD) fail error.	Pause
856D	DIMM_D2 Component encountered a Serial Presence Detection (SPD) fail error.	Pause
856E	DIMM_D3 Component encountered a Serial Presence Detection (SPD) fail error.	Pause
856F	DIMM_D4 Component encountered a Serial Presence Detection (SPD) fail error.	Pause
8580	DIMM_A1 Correctable ECC error encountered.	Pause after 10 Occurrence
8581	DIMM_A2 Correctable ECC error encountered.	Pause after 10 Occurrence
8582	DIMM_A3 Correctable ECC error encountered.	Pause after 10 Occurrence
8583	DIMM_A4 Correctable ECC error encountered.	Pause after 10 Occurrence
8584	DIMM_B1 Correctable ECC error encountered.	Pause after 10 Occurrence
8585	DIMM_B2 Correctable ECC error encountered.	Pause after 10 Occurrence
8586	DIMM_B3 Correctable ECC error encountered.	Pause after 10 Occurrence
8587	DIMM_B4 Correctable ECC error encountered.	Pause after 10 Occurrence
8588	DIMM_C1 Correctable ECC error encountered.	Pause after 10 Occurrence
8589	DIMM_C2 Correctable ECC error encountered.	Pause after 10 Occurrence
858A	DIMM_C3 Correctable ECC error encountered.	Pause after 10 Occurrence
858B	DIMM_C4 Correctable ECC error encountered.	Pause after 10 Occurrence
858C	DIMM_D1 Correctable ECC error encountered.	Pause after 10 Occurrence
858D	DIMM_D2 Correctable ECC error encountered.	Pause after 10 Occurrence
858E	DIMM_D3 Correctable ECC error encountered.	Pause after 10 Occurrence
858F	DIMM_D4 Correctable ECC error encountered.	Pause after 10 Occurrence
85A0	DIMM_A1 Uncorrectable ECC error encountered.	Pause
85A1	DIMM_A2 Uncorrectable ECC error encountered.	Pause
85A2	DIMM_A3 Uncorrectable ECC error encountered.	Pause
85A3	DIMM_A4 Uncorrectable ECC error encountered.	Pause
85A4	DIMM_B1 Uncorrectable ECC error encountered.	Pause
85A5	DIMM_B2 Uncorrectable ECC error encountered.	Pause
85A6	DIMM_B3 Uncorrectable ECC error encountered.	Pause
85A7	DIMM_B4 Uncorrectable ECC error encountered.	Pause
85A8	DIMM_C1 Uncorrectable ECC error encountered.	Pause
85A9	DIMM_C2 Uncorrectable ECC error encountered.	Pause
85AA	DIMM_C3 Uncorrectable ECC error encountered.	Pause
85AB	DIMM_C4 Uncorrectable ECC error encountered.	Pause
85AC	DIMM_D1 Uncorrectable ECC error encountered.	Pause
85AD	DIMM_D2 Uncorrectable ECC error encountered.	Pause
85AE	DIMM_D3 Uncorrectable ECC error encountered.	Pause
85AF	DIMM_D4 Uncorrectable ECC error encountered.	Pause
8601	Override jumper is set to force boot from lower alternate BIOS bank of flash ROM.	No Pause
8602	WatchDog timer expired (secondary BIOS may be bad!).	No Pause
8603	Secondary BIOS checksum fail.	No Pause



Error Code	Error Message	Response
8604	Chipset Reclaim of non-critical variables complete.	No Pause
9000	Unspecified processor component has encountered a non-specific error.	Pause
9223	Keyboard component was not detected.	No Pause
9226	Keyboard component encountered a controller error.	No Pause
9243	Mouse component was not detected.	No Pause
9246	Mouse component encountered a controller error.	No Pause
9266	Local Console component encountered a controller error.	No Pause
9268	Local Console component encountered an output error.	No Pause
9269	Local Console component encountered a resource conflict error.	No Pause
9286	Remote Console component encountered a controller error.	No Pause
9287	Remote Console component encountered an input error.	No Pause
9288	Remote Console component encountered an output error.	No Pause
92A3	Serial port component was not detected	Pause
92A9	Serial port component encountered a resource conflict error.	Pause
92C6	Serial Port controller error	No Pause
92C7	Serial Port component encountered an input error.	No Pause
92C8	Serial Port component encountered an output error.	No Pause
94C6	LPC component encountered a controller error.	No Pause
94C9	LPC component encountered a resource conflict error.	Pause
9506	ATA/ATPI component encountered a controller error.	No Pause
95A6	PCI component encountered a controller error.	No Pause
95A7	PCI component encountered a read error.	No Pause
95A8	PCI component encountered a write error.	No Pause
9609	Unspecified software component encountered a start error.	No Pause
9641	PEI Core component encountered a load error.	No Pause
9667	PEI module component encountered an illegal software state error.	Halt
9687	DXE core component encountered an illegal software state error.	Halt
96A7	DXE boot services driver component encountered an illegal software state error.	Halt
96AB	DXE boot services driver component encountered invalid configuration.	No Pause
96E7	SMM driver component encountered an illegal software state error.	Halt
0xA022	Processor component encountered a mismatch error.	Pause
0xA027	Processor component encountered a low voltage error.	No Pause
0xA028	Processor component encountered a high voltage error.	No Pause
0xA421	PCI component encountered a SERR error.	Halt
0xA500	ATA/ATPI ATA bus SMART not supported.	No Pause
0xA501	ATA/ATPI ATA SMART is disabled.	No Pause
0xA5A0	PCI Express* component encountered a PERR error.	No Pause
0xA5A1	PCI Express* component encountered a SERR error.	Halt
0xA5A4	PCI Express* IBIST error.	Pause
0xA6A0	DXE boot services driver Not enough memory available to shadow a legacy option ROM.	No Pause

## POST Error Beep Codes

The following table lists POST error beep codes. Prior to system video initialization, the BIOS uses these beep codes to inform users on error conditions. The beep code is followed by a user-visible code on POST Progress LEDs.

**Table 68. POST Error Beep Codes**

Beeps	Error Message	POST Progress Code	Description
3	Memory error	Multiple	System halted because a fatal error related to the memory was detected.

## USB Device Beeps When POST

Intel® Server Boards of the H2600 family are designed to indicate USB readiness by a series of beep codes early during POST, just before video becomes available. These four to five beeps mean that the USB is powered and initialized, in order for USB devices such as keyboard and mouse to become operational.

If a USB device such as a pen drive or USB CD/DVD ROM drive is attached to any external USB port, a beep code means that the device is recognized, powered and initialized. Each USB port will issue a beep once an external device is ready for use.

These beep codes do not signal any errors. They are designed to advise the user of USB readiness during POST and while attaching external devices.

This USB Beep is OS Independent.

## Glossary

Term	Definition
ACPI	Advanced Configuration and Power Interface
AP	Application Processor
APIC	Advanced Programmable Interrupt Control
ASIC	Application Specific Integrated Circuit
ASMI	Advanced Server Management Interface
BIOS	Basic Input/Output System
BIST	Built-In Self Test
BMC	Baseboard Management Controller
Bridge	Circuitry connecting one computer bus to another, allowing an agent on one to access the other
BSP	Bootstrap Processor
Byte	8-bit quantity.
CBC	Chassis Bridge Controller (A microcontroller connected to one or more other CBCs, together they bridge the IPMB buses of multiple chassis.)
CEK	Common Enabling Kit
CHAP	Challenge Handshake Authentication Protocol
CMOS	In terms of this specification, this describes the PC-AT compatible region of battery-backed 128 bytes of memory, which normally resides on the server board
DPC	Direct Platform Control
EEPROM	Electrically Erasable Programmable Read-Only Memory
EHCI	Enhanced Host Controller Interface
EMP	Emergency Management Port
EPS	External Product Specification
ESB2-E	Enterprise South Bridge 2
FBD	Fully Buffered DIMM
FMB	Flexible Mother Board
FRB	Fault Resilient Booting
FRU	Field Replaceable Unit
FSB	Front Side Bus
GB	1024MB
GPIO	General Purpose I/O
GTL	Gunning Transceiver Logic
HSC	Hot-Swap Controller
Hz	Hertz (1 cycle/second)
I <sup>2</sup> C	Inter-Integrated Circuit Bus
IA	Intel® Architecture
IBF	Input Buffer
ICH	I/O Controller Hub
ICMB	Intelligent Chassis Management Bus
IERR	Internal Error
IFB	I/O and Firmware Bridge
INTR	Interrupt

Term	Definition
IP	Internet Protocol
IPMB	Intelligent Platform Management Bus
IPMI	Intelligent Platform Management Interface
IR	Infrared
ITP	In-Target Probe
KB	1024 bytes
KCS	Keyboard Controller Style
LAN	Local Area Network
LCD	Liquid Crystal Display
LED	Light Emitting Diode
LPC	Low Pin Count
LUN	Logical Unit Number
MAC	Media Access Control
MB	1024KB
MCH	Memory Controller Hub
MD2	Message Digest 2 – Hashing Algorithm
MD5	Message Digest 5 – Hashing Algorithm – Higher Security
ms	milliseconds
MTTR	Memory Type Range Register
Mux	Multiplexor
NIC	Network Interface Controller
NMI	Nonmaskable Interrupt
OBF	Output Buffer
OEM	Original Equipment Manufacturer
Ohm	Unit of electrical resistance
PEF	Platform Event Filtering
PEP	Platform Event Paging
PIA	Platform Information Area (This feature configures the firmware for the platform hardware.)
PLD	Programmable Logic Device
PMI	Platform Management Interrupt
POST	Power-On Self Test
PSMI	Power Supply Management Interface
PWM	Pulse-Width Modulation
RAM	Random Access Memory
RASUM	Reliability, Availability, Serviceability, Usability, and Manageability
RISC	Reduced Instruction Set Computing
RMM3	Remote Management Module – Third generation
RMM3 NIC	Remote Management Module – Third generation dedicated management NIC
ROM	Read Only Memory
RTC	Real-Time Clock (Component of ICH peripheral chip on the server board.)
SDR	Sensor Data Record
SECC	Single Edge Connector Cartridge
SEEPRAM	Serial Electrically Erasable Programmable Read-Only Memory

Term	Definition
SEL	System Event Log
SIO	Server Input/Output
SMI	Server Management Interrupt (SMI is the highest priority nonmaskable interrupt.)
SMM	Server Management Mode
SMS	Server Management Software
SNMP	Simple Network Management Protocol
SSI	Server System Infrastructure
TBD	To Be Determined
TIM	Thermal Interface Material
UART	Universal Asynchronous Receiver/Transmitter
UDP	User Datagram Protocol
UHCI	Universal Host Controller Interface
UTC	Universal time coordinate
VID	Voltage Identification
VRD	Voltage Regulator Down
Word	16-bit quantity
ZIF	Zero Insertion Force

## Reference Documents

Refer to the following documents for additional information:

- *Intel® Server Board S2600WP Technical Product Specification (Intel Order Code: G31608)*
- ACPI 3.0: <http://www.acpi.info/spec.htm>
- IPMI 2.0
- *Data Center Management Interface Specification v1.0*, May 1, 2008: [www.intel.com/go/dcmi](http://www.intel.com/go/dcmi)
- *PCI Bus Power Management Interface Specification 1.1*: <http://www.pcisig.com/>
- *PCI Express\* Base Specification Rev 2.0 Dec 06*: <http://www.pcisig.com/>
- *PCI Express\* Card Electromechanical Specification Rev 2.0*: <http://www.pcisig.com/>
- PMBus\*: <http://pmbus.org>
- SATA 2.6: <http://www.sata-io.org/>
- SMBIOS 2.4
- SSI-EEB 3.0: <http://www.ssiforum.org>
- USB 1.1: <http://www.usb.org>
- USB 2.0: <http://www.usb.org>
- Windows Logo/SDG 3.0
- *Intel® Dynamic Power Technology Node Manager 1.5 External Interface Specification using IPMI, 2007*. Intel Corporation.
- *Node Power and Thermal Management Architecture Specification v1.5, rev.0.79. 2007*, Intel Corporation.
- *Intel® Server System Integrated Baseboard Management Controller Core External Product Specification, 2007* Intel Corporation.
- *Intel® Thurley Server Platform Services IPMI Commands Specification, 2007*. Intel Corporation.
- *Intel® Server Safety and Regulatory, 2011*. Intel Corporation. (Intel Order Code: G23122)
- *Intelligent Platform Management Bus Communications Protocol Specification, Version 1.0, 1998*. Intel Corporation, Hewlett-Packard Company, NEC Corporation, Dell Computer Corporation.
- *Platform Environmental Control Interface (PECI) Specification, Version 2.0*. Intel Corporation.
- *Platform Management FRU Information Storage Definition, Version 1.0, Revision 1.2, 2002*. Intel Corporation, Hewlett-Packard Company, NEC Corporation, Dell Computer Corporation: <http://developer.intel.com/design/servers/ipmi/spec.htm>.