



Intel® Entry Server Board SE7230NH1-E Quick Start User's Guide

Thank you for buying the Intel® Entry Server Board SE7230NH1-E. The following information will help you integrate your new server board into a server chassis. The Intel® Entry Server Board SE7230NH1-E is designed for use with the Intel® Entry Server Chassis SC5295-E (Product Code SC5295UP only).

For details on this chassis or to select a third party chassis, please see <http://www.intel.com/go/serverbuilder> and <http://support.intel.com/support/motherboards/server>.

When installing the server board into a reference chassis, refer to the reference chassis instructions.

User Guides are also available on the CD that accompanied your Intel® Entry Server Board SE7230NH1-E.

If you are not familiar with ESD (Electrostatic Discharge) procedures used during system integration, please see the Intel® Entry Server Board SE7230NH1-E User's Guide, available on the CD or at <http://support.intel.com/support/motherboards/server/se7230nh1-e/manual.htm>.

Warning

Read all caution and safety statements in this document before performing any of the instructions. Also see the *Intel® Server Board and Server Chassis Safety Information* document at: <http://support.intel.com/support/motherboards/server/sb/cs-010770.htm> for complete safety information.

Warning

Installation and service of this product to be performed only by qualified service personnel to avoid risk of injury from electrical shock or energy hazard.

Caution

Observe normal ESD (Electrostatic Discharge) procedures during system integration to avoid possible damage to server board and/or other components.

Tools Required

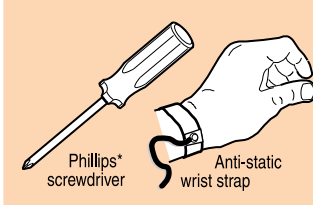

Fastener Identification Guide

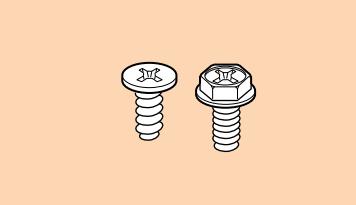

4 Install the Processor

Notes and Cautions:

- When unpacking a processor, hold by the edges only to avoid touching the pins.
- This server board has a "zero-insertion force" socket. If processor does not drop easily into socket, make sure lever is in the full-open position.

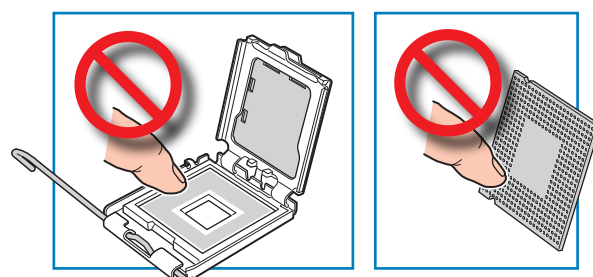

A. Open the Socket Lever

- Push the lever handle down and away from the socket to release it.
- Pull the lever and open all the way.

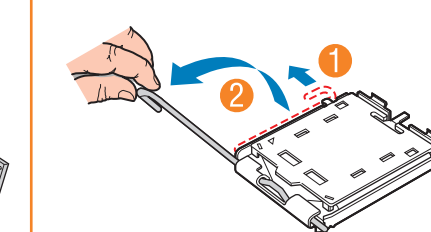

B. Open the Load Plate

- Push the rear tab with your finger tip to bring the front end of the load plate up slightly.
- Open the load plate as shown.

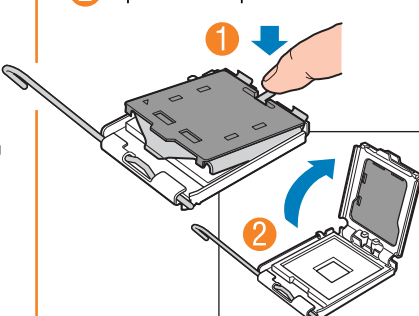

C. Remove the Processor Protective Cover

- Take the processor out of the box and remove the protective shipping cover.

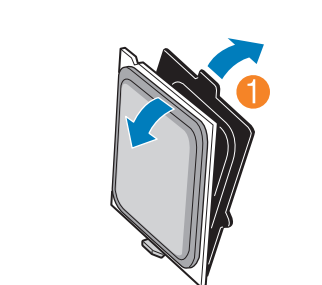

D. Install the Processor

- Orient the processor with the socket so that the processor cutout matches the socket notch.
- Install the processor as shown.

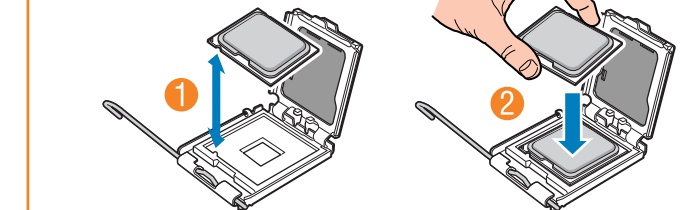

E. Remove Socket Protective Cover

- Grasp the socket protective cover tab and pull away from the load plate as shown.
- Remove the socket protective cover and store for future use.

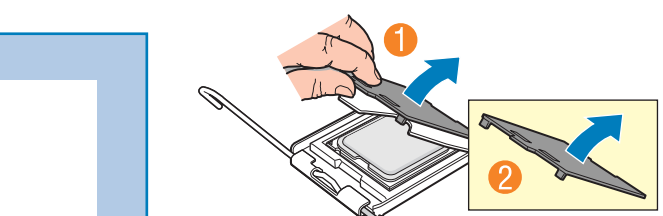

F. Close Load Plate and Socket Lever

- Close the load plate all the way as shown.
- With your finger, push down on the load plate as shown.
- Close the socket lever and ensure that the load plate tab engages under the socket lever when fully closed.

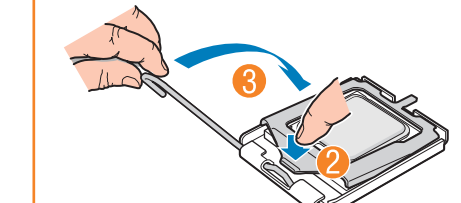

D23182-003



Minimum Hardware Requirements

To avoid integration difficulties and possible board damage, your system must meet the following minimum requirements:

- Processor: Intel® Pentium® D or Intel® Pentium® 4 Processor, minimum 2.8 GHz with chassis compatible fan/heat sink.
- Memory Type: Minimum of one 256MB, DDR2 400/533/667 MHz compliant unbuffered, ECC or non-ECC, SPD SDRAM 240-pin gold DIMM.
- Power: Minimum of 350W with 2A of standby current, which meets the SSI EPS 12V specification.

1 Preparing the Chassis

When using an Intel® Server Chassis, begin with the Quick Start User's Guide that came with your chassis. Return to this document when directed by the server chassis Quick Start User's Guide. If using a non-Intel server chassis, refer to the documentation that came with your chassis for preparatory steps.

3 Install the Server Board

A. Insert the Server Board

Place the board into the chassis, making sure that back panel I/O ports and chassis or I/O shield openings align correctly. Verify that server board mounting holds align correctly with the chassis standoffs.

When using the Intel® Server Chassis SC5295-E, insert the I/O connector side (back) of the board first.

When using the Intel® Server Chassis SR1475, place the board into the chassis as shown.

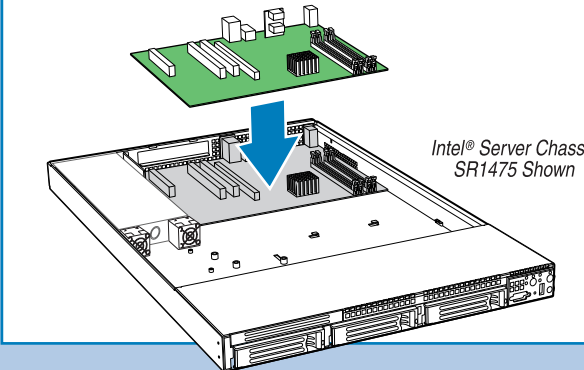

B. Attach the Server Board

Note: The Intel® Server Chassis SC5295-E, Intel® Server Chassis SR1475 and a non-Intel chassis may use different fasteners to attach the server board to the chassis. Use the fasteners that came with your chassis.

Intel® Server Chassis SC5295-E and SR1475

Use screws to attach the board to the chassis at the 9 locations indicated by the solid RED arrows in the figure.

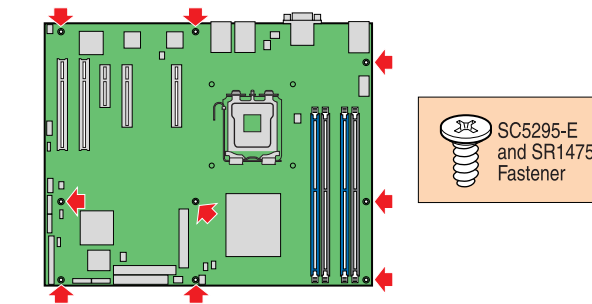

2 Installing the I/O Shield and Gasket

If you are integrating the Intel® Server Chassis SR1475, disregard this step.

- Attach the Gasket to the I/O Shield
- Attach the Labels to the I/O Shield
- Install the I/O shield

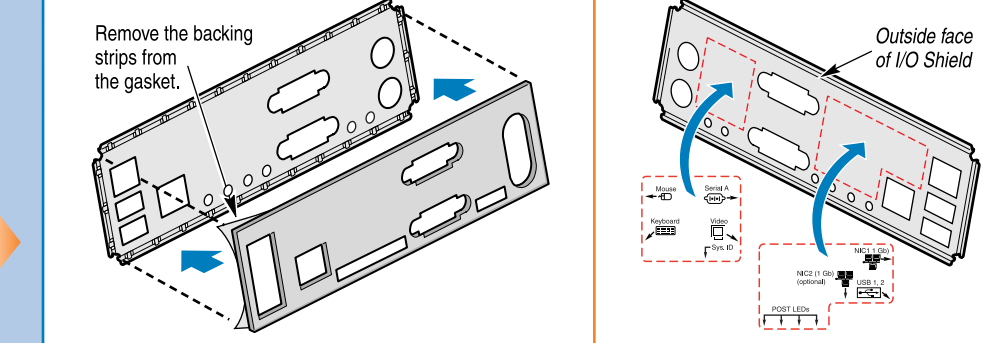

Remove the backing strips from the gasket. Press the gasket onto the inside face of the I/O shield as shown.

Remove the backing from the labels included with your server board. Press the labels onto the outside face of the I/O shield as shown.

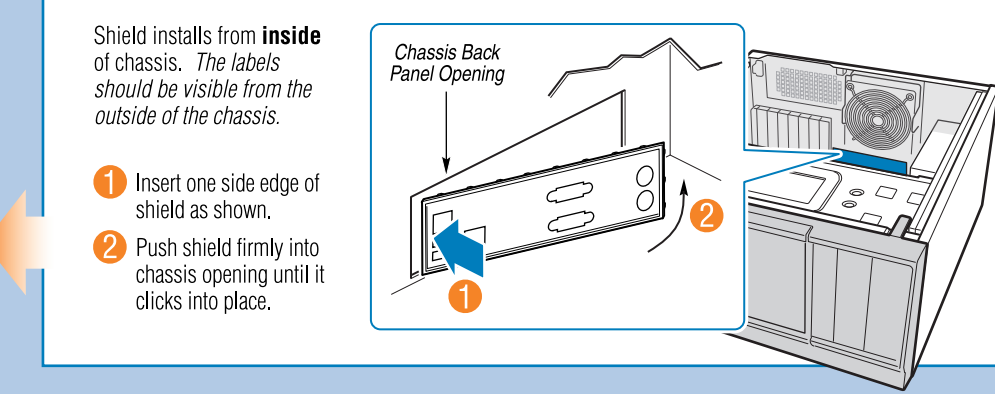

Shield installs from inside of chassis. The labels should be visible from the outside of the chassis.

- Insert one side edge of shield as shown.
- Push shield firmly into chassis opening until it clicks into place.

5 Install Passive Heat Sink

Important Note: Install the heat sink indicated for your server chassis in Step 5 or Step 6.

This heat sink is required for the Intel® Server Chassis SR1475.

CAUTION: The heat sink has thermal interface material (TIM) on the underside of it. Use caution so that you do not damage the thermal interface material. Use gloves to avoid sharp edges.

- Remove the protective film on the TIM.
- Align heat sink fins to the front and back of the chassis for correct airflow.
- Lightly tighten each fastener diagonally, according to the numbers shown.
- Securely re-tighten each fastener again in the same order as performed in step B.

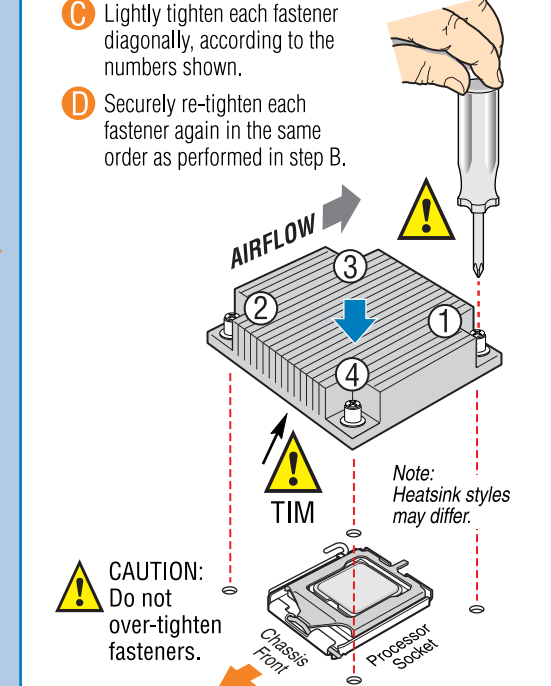

CAUTION: Do not over-tighten fasteners.

6 Install Active Heat Sink

An active heat sink is required for the Intel® Server Chassis SC5295-E. A typical active heat sink is shown below.

CAUTION: The heat sink has thermal interface material (TIM) on the underside of it. Use caution so that you do not damage the thermal interface material. Use gloves to avoid sharp edges.

Use the following procedure to install an active heat sink to your server board:

- Make sure the screwdriver slot at the top of each fastener is rotated perpendicular to the blades of the heat sink as shown.
- Align heat sink with holes in board and lower assembly to board. Snaps go through holes in server board.
- Press downward on top of cap.
- Fastener snaps into final position.

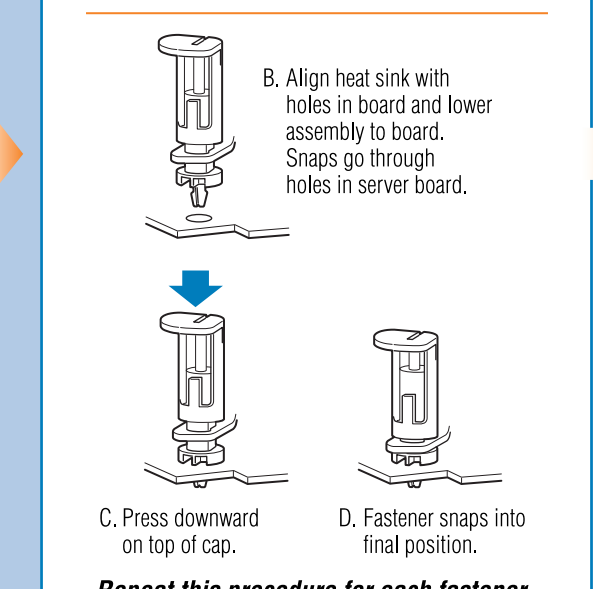

Repeat this procedure for each fastener.

7 Install DIMM Memory

This server board does not support DDR memory. You must install DDR2 DIMMs to avoid possible damage to server board DIMM sockets.

DDR2 DIMM Memory Identification:

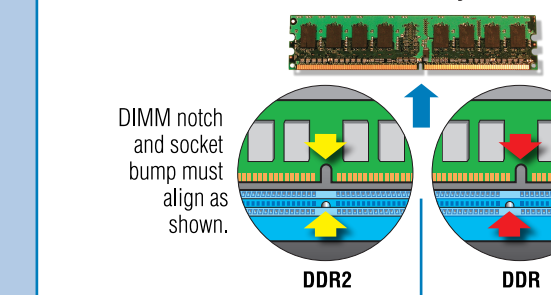

Memory Type: Minimum of one 256MB, DDR2 400/533/667 MHz compliant unbuffered, ECC or non-ECC, SPD SDRAM 240-pin gold DIMM.

Notes and Cautions: Populate DIMMs in the order of: 1A, 1B, 2A and 2B

The DIMM size, speed and vendor must be the same within a bank. However, the DIMM size can vary between banks. For example, Bank 1 can use two 256 MB DIMMs and Bank 2 can use two 512 MB DIMMs.

Note: For additional memory configurations, see the User Guide on the CD that accompanied your Intel® Server Board SE7230NH1-E, or go to: <http://support.intel.com/support/motherboards/server/se7230nh1-e>

Memory sizing and configuration is guaranteed only for qualified DIMMs approved by Intel®.

CAUTION: Avoid touching gold contacts when handling or installing DIMMs.

To Install DIMMs:

- Open both DIMM socket levers.
- Note location of alignment notch.
- Insert DIMM making sure the connector edge of the DIMM aligns correctly with the slot.
- Push down firmly on the DIMM until it snaps into place and both levers close.

