

# **Intel® Server Chassis P4000S Family**

## ***Technical Product Specification***

*Intel reference number G22850-002*

**Revision 1.1**

**March, 2011**

**Enterprise Platforms and Services Marketing**

---

## ***Revision History***

Date	Revision Number	Modifications
July, 2010	0.5	Initial release.
December, 2010	1.0	Updated the document.
March, 2011	1.1	Added the P4304XXSHCN related features.

## ***Disclaimers***

Information in this document is provided in connection with Intel® products. No license, express or implied, by estoppel or otherwise, to any intellectual property rights is granted by this document. Except as provided in Intel's Terms and Conditions of Sale for such products, Intel assumes no liability whatsoever, and Intel disclaims any express or implied warranty, relating to sale and/or use of Intel products including liability or warranties relating to fitness for a particular purpose, merchantability, or infringement of any patent, copyright or other intellectual property right. Intel products are not intended for use in medical, life saving, or life sustaining applications. Intel may make changes to specifications and product descriptions at any time, without notice.

Designers must not rely on the absence or characteristics of any features or instructions marked "reserved" or "undefined." Intel reserves these for future definition and shall have no responsibility whatsoever for conflicts or incompatibilities arising from future changes to them.

This document contains information on products in the design phase of development. Do not finalize a design with this information. Revised information will be published when the product is available. Verify with your local sales office that you have the latest datasheet before finalizing a design.

The Intel® Server Chassis P4000S Family may contain design defects or errors known as errata which may cause the product to deviate from published specifications. Current characterized errata are available on request.

Intel Corporation server baseboards contain a number of high-density VLSI and power delivery components that need adequate airflow to cool. Intel's own chassis are designed and tested to meet the intended thermal requirements of these components when the fully integrated system is used together. It is the responsibility of the system integrator that chooses not to use Intel developed server building blocks to consult vendor datasheets and operating parameters to determine the amount of air flow required for their specific application and environmental conditions. Intel Corporation cannot be held responsible if components fail or the server board does not operate correctly when used outside any of their published operating or non-operating limits.

Intel, Pentium, Itanium, and Xeon are trademarks or registered trademarks of Intel Corporation.

\*Other brands and names may be claimed as the property of others.

Copyright © Intel Corporation 2005-2011

# Table of Contents

<b>1. Product Overview</b> .....	<b>1</b>
1.1 Intel® Server Chassis P4000S Family Design Features .....	1
1.2 Intel® Server Chassis P4304XXSFCN Views .....	2
1.3 Intel® Server Chassis P4304XXSHCN Views .....	3
1.4 Chassis Security .....	4
1.5 I/O Panel.....	4
1.6 Front Bezel Features .....	4
1.7 Standard Fixed Drive Trays .....	6
1.8 4x3.5” Hot-Swap Hard Disk Drive Cage .....	6
1.8.1 3.5” Hot-swap Hard Drive Carrier .....	7
1.9 Peripheral Bays .....	7
<b>2. Chassis Power Sub-system</b> .....	<b>9</b>
2.1 365-W Power Supply .....	9
2.1.1 Mechanical Overview.....	9
2.1.2 365-W Power Supply Output Wire Harness .....	11
2.1.3 Temperature Requirements.....	13
2.1.4 AC Input Requirements .....	14
2.1.5 Efficiency .....	15
2.1.6 DC Output Specification .....	16
2.1.7 Protection Circuits.....	22
2.1.8 Control and Indicator Functions.....	22
<b>3. Chassis Cooling</b> .....	<b>25</b>
3.1 Cooling solution for Intel® Server Board S1200BT Series .....	25
3.2 Server Board Fan Control.....	26
3.3 Fan Header Connector Descriptions .....	26
<b>4. Standard Front Panel</b> .....	<b>27</b>
4.1 Front Panel Overview .....	27
4.2 Front Panel Features .....	27
4.3 Common Front Panel Placement.....	28
4.3.1 Common Front Panel LED Functionality .....	28
4.4 Common Front Panel Connector List & Pinouts .....	29
4.4.1 Pinouts.....	29

<b>5. 4x3.5" Hot-Swap Back Plane (HSBP)</b> .....	<b>31</b>
5.1 Overview .....	31
5.1.1 Key Features .....	31
5.1.2 Board Layout .....	31
5.2 4x 3.5" HSBP Functional Description .....	32
5.2.1 4x3.5" HSBP Microcontroller .....	32
5.2.2 SGPIO Functionality .....	33
5.2.3 I2C Functionality .....	34
5.2.4 HSBP LED Functionality .....	35
5.2.5 HDD Numbering Scheme .....	35
5.3 4x3.5" HSBP Connector List and Pinouts .....	36
5.3.1 Pinouts .....	36
5.4 4x3.5" HSBP Supported Servers & Baseboards .....	37
5.5 4x3.5" HSBP Cabling Requirements .....	38
<b>6. System Interconnection</b> .....	<b>39</b>
6.1 Chassis Internal Cables .....	39
6.1.1 Front Panel Cable .....	39
6.1.2 Intrusion Switch cable .....	39
6.1.3 USB Cable .....	39
6.1.4 SATA Power Adapter Cable .....	40
6.1.5 SATA cable for HDDs/ODD .....	40
6.1.6 I2C Cable .....	41
6.1.7 SGPIO Cable .....	41
<b>7. System-Compatible Intel® Server Boards</b> .....	<b>43</b>
<b>8. Reliability, Serviceability, and Availability</b> .....	<b>44</b>
8.1 Mean Time between Failure .....	44
8.2 Serviceability .....	44
<b>9. Environmental Limits</b> .....	<b>46</b>
9.1 System Office Environment .....	46
9.2 System Environmental Testing .....	46
<b>10. Product Regulatory Compliance</b> .....	<b>48</b>
<b>Appendix A: Integration and Usage Tips</b> .....	<b>49</b>
<b>Glossary</b> .....	<b>50</b>

# List of Figures

Figure 1. Internal Chassis View of Intel® Server Chassis P4304XXSFCN .....	3
Figure 2. Internal Chassis View of Intel® Server Chassis P4304XXSHCN .....	4
Figure 3. ATX 2.2 I/O Aperture .....	4
Figure 4. Front Closed Chassis View with Front Bezel for Fixed Hard Drives Configuration .....	5
Figure 5. Front Closed Chassis View with Front Bezel for Hot-swap Hard Drives Configuration .	5
Figure 6. Fixed Drive Tray .....	6
Figure 7. 4x3.5" Hot-Swap Hard Disk Drive Cage .....	7
Figure 8. 3.5" hot-swap hard drive carrier with 2.5" HDD Interface Bracket .....	7
Figure 9. Tool-less Rails Mounting 5.25-inch CD-ROM Drive .....	8
Figure 10. Mechanical Drawing for 365-W Power Supply Enclosure .....	10
Figure 11. Output Cable Harness for 365-W Power Supply .....	11
Figure 12. Differential Noise test setup .....	19
Figure 13. Output Voltage Timing .....	20
Figure 14. Turn On/Off Timing (Power Supply Signals).....	21
Figure 15. PSON# Required Signal Characteristic .....	23
Figure 16. Active Heat Sink and Chassis Rear Fan in Intel® Server Chassis P4304XXSFCN ...	25
Figure 17. Front Panel overview .....	27
Figure 18. Common Front Panel LED/Button Arrangement.....	28
Figure 19. 8x3.5" HSBP Board Layout.....	32
Figure 20. 4x 3.5" HSBP I2C Connectivity .....	34
Figure 21. 4x 3.5" HSBP HDD Numbering Scheme .....	36
Figure 22. Chassis Front Panel Cable .....	39
Figure 23. Intrusion Switch Cable .....	39
Figure 24. USB Cable Drawing .....	40
Figure 25. SATA Power Adapter Cable .....	40
Figure 26. SATA cable for HDDs (450mm).....	41
Figure 27. I2C Cable.....	41

# List of Tables

Table 1. Intel® Server Chassis P4000S family Features.....	2
Table 2. 365-W Power Supply Cable Lengths .....	12
Table 3. P1 Main Power Connector .....	12
Table 4. P2 Processor#1 Power Connector.....	12
Table 5. Peripheral Power Connectors .....	13
Table 6. SATA Power Connector .....	13
Table 7. Thermal Requirements .....	13
Table 8. Power Factor Requirements for Computer Servers.....	14
Table 9. AC Input Voltage Range .....	14
Table 10. AC Line Holdup Time.....	14
Table 11. AC Line Sag Transient Performance .....	15
Table 12. AC Line Surge Transient Performance .....	15
Table 13. Silver Efficiency Requirement.....	16
Table 14. Over Voltage Protection Limits .....	16
Table 15. Loading Conditions .....	16
Table 16. Voltage Regulation Limits .....	17
Table 17. Transient Load Requirements.....	17
Table 18. Capacitive Loading Conditions .....	18
Table 19. Ripples and Noise.....	19
Table 20. Output Voltage Timing .....	19
Table 21. Turn On/Off Timing .....	21
Table 22. Over Voltage Protection (OVP) Limits .....	22
Table 23. PSON# Signal Characteristic.....	23
Table 24. PWOK Signal Characteristics .....	23
Table 25. Front Panel LED Functionality .....	28
Table 26. Connectors for Boards .....	29
Table 27. Pinouts Signal Description .....	29
Table 28. Chassis Intrusion Pin-out.....	30
Table 29. 4x3.5" HSBP Microcontroller Pinouts.....	32
Table 30. Romley LED Functionality.....	35
Table 31. HDD Activity LED Functionality.....	35
Table 32. 4x3.5" HSBP Connector List.....	36

Table 33. 4x3.5" HSBP SGPIO Connector Pinouts ..... 36

Table 34. 4x3.5" HSBP I2C(In) Connector Pinouts..... 37

Table 35. 4x3.5" HSBP I2C (Out) Connector List ..... 37

Table 36. 4x3.5" HSBP Power Connector Pinouts ..... 37

Table 37. 4 x 3.5" HSBP Supported Chassis & Associated Baseboards..... 37

Table 38. System-Compatible Intel® Server Boards ..... 43

Table 39. Calculated Mean Time Between Failure ..... 44

Table 40. Maximum Maintenance Procedure Times ..... 45

Table 41. System Office Environment Summary ..... 46

<This page is intentionally left blank.>



# 1. Product Overview

---

The Intel® Server Chassis P4000S family is a 4U pedestal, 22" length server chassis that is designed to support Intel® Server Board S1200BTL, S1200BTS. This chapter provides a high-level overview of the chassis features. Greater detail for each major chassis component or feature is provided in the following chapters.

## 1.1 Intel® Server Chassis P4000S Family Design Features

The Intel® Server Chassis P4000S family is designed to address the entry-level market. The Intel® Server Chassis P4000S Family make extensive use of tool-less hardware features and, depending on configuration and upgrade features, provides redundant power supply and hot swappable hard drives capability. The Intel® Server Chassis P4000S family comes with the following configurations:

- P4304XXSFCN – 365-W non-redundant PSU and up to four 3.5" fixed hard drives
- P4304XXSHCN – 365-W non-redundant PSU and up to four 3.5" hot-swap hard drives

Intel® Server Chassis P4304XXSFCN includes a fixed single 365W non-redundant 80+ Silver power supply. One SATA/SAS fixed drive bay kit allows support for four fixed SATA/SAS drives. One tachometer output fan (92mmX38mm) is mounted at the back edge of the chassis. Three 5.25-inch half-height peripheral bays are available for the installation of a floppy drive, CD-ROM drive, and/or other accessories. The standard chassis configuration is pedestal.

Intel® Server Chassis P4304XXSHCN includes a fixed single 365W non-redundant 80+ Silver power supply. One 4x3.5" hot-swap hard drive cage kit allows support for four hot-swap SATA/SAS drives. One tachometer output fan (92mmX38mm) is mounted at the back edge of the chassis. Three 5.25-inch half-height peripheral bays are available for the installation of a floppy drive, CD-ROM drive, and/or other accessories. The standard chassis configuration is pedestal.

The following table summarizes the features for all chassis combinations.

**Table 1. Intel® Server Chassis P400S family Features**

Configuration	P4304XXSFCN	P4304XXSHCN
Intel® Server Board Support	Intel® Server Board S1200BTL Intel® Server Board S1200BTS	Intel® Server Board S1200BTL
Power	365W non-redundant power supply with integrated cooling fan	
System Cooling	One 92-mm system rear fan	
Peripherals Bays	Three (3) half height 5-1/4" bays for optical devices.	
Drive Bays	Includes one fixed drive bay. Supports up to four fixed hard drives.	Includes one 4x3.5" hot-swap hard drive cage. Supports up to four hot-swap hard drives.
Expansion Slots	Up to Six (6) full height, full length PCI form factor cards	
Front Panel	Power Button with LED, Reset Button, NMI Button, ID Button with LED, Four NIC LEDs, Hard drive activity LED, System status LED, two USB ports, Optional front serial port/VGA port	
Appearance	Color: Cosmetic black (GE 701 or equivalent), service Intel blue, hot swap Intel green. Support for Intel standard front panel or LCD	
Dimensions Pedestal	17.24 in (438 mm) x 6.81 in (173mm) x 22.05 in (560 mm) (Height X Width X Depth)	
Optional Accessory Kits	Zephyr flash storage, RMM4-lite modules, TPM module, dedicated NIC module	

## 1.2 Intel® Server Chassis P4304XXSFCN Views

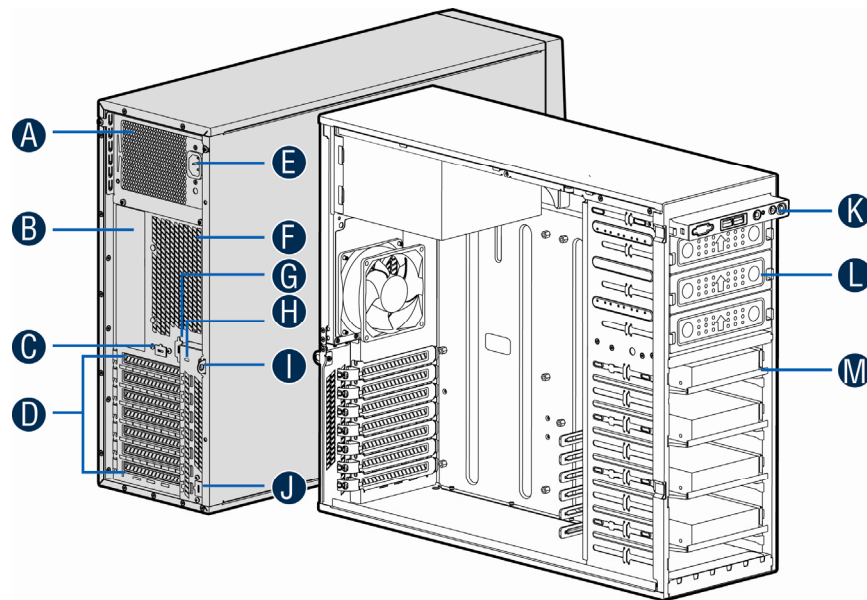

AF003896

A. 365-W Fixed Power supply

- B. I/O Ports
- C. Alternate RMM4 Knockout
- D. PCI Add-in Board Slot Covers
- E. AC Input Power Connector
- F. 92-mm System Rear Fan
- G. Serial Port Knockout
- H. A Kensington\* Cable Lock Mounting Hole
- I. Padlock Loop
- J. Alternate RMM4 Knockout
- K. Front Control Panel
- L. Alternate 5.25" Peripheral Bays
- M. Hard Drive Bays

Figure 1. Internal Chassis View of Intel® Server Chassis P4304XXSFCN

### 1.3 Intel® Server Chassis P4304XXSHCN Views

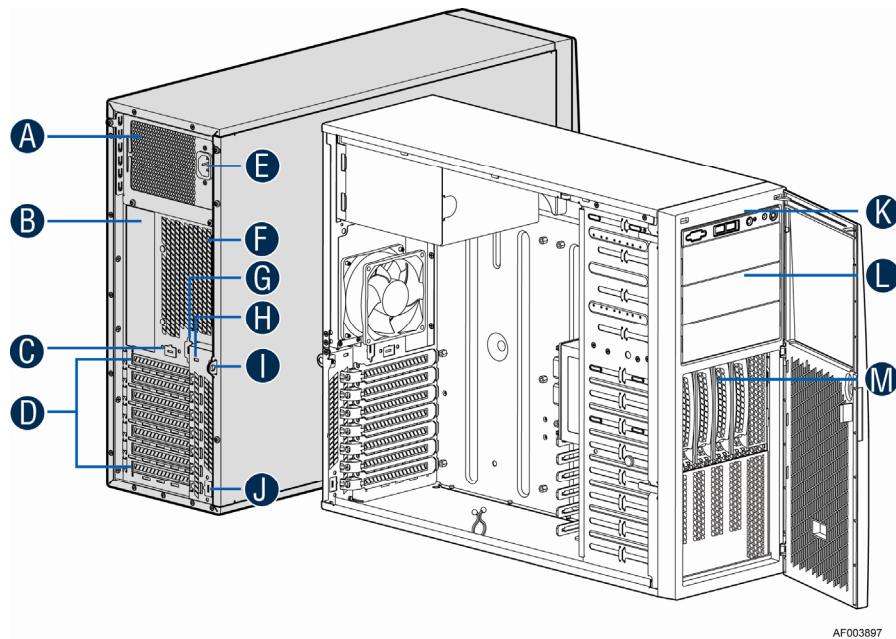

- A. 365-W Fixed Power Supply
- B. I/O Ports
- C. Alternate RMM4 Knockout
- D. PCI Add-in Board Slot Covers
- E. AC Input Power Connector
- F. 92-mm System Rear Fan
- G. Serial Port Knockout
- H. A Kensington\* Cable Lock Mounting Hole
- I. Padlock Loop
- J. Alternate RMM4 Knockout
- K. Front Control Panel

- L. 5.25" Peripheral Bays
- M. 4X3.5" Hot-swap HDD Cage

**Figure 2. Internal Chassis View of Intel® Server Chassis P4304XXSHCN**

## 1.4 Chassis Security

A variety of chassis security options are provided at the system level:

- A removable padlock loop at the rear of the system access cover can be used to prevent access to the microprocessors, memory, and add-in cards. A variety of lock sizes can be accommodated by the 0.270-inch diameter loop.
- A Kensington\* cable lock mounting hole is provided on the rear chassis I/O panel.
- A chassis intrusion switch is provided, allowing server management software to detect unauthorized access to the system side cover.
- In hot-swap hard drives configuration, a door lock is provided on the front bezel assembly with the door to prevent access to the hot-swap hard drives and the interior of the chassis.

---

**Note:** See the technical product specification appropriate to the server board for a description of BIOS and management security features for each specific supported platform. Technical product specifications can be found at <http://www.intel.com/support>.

---

## 1.5 I/O Panel

All input/output (I/O) connectors are accessible from the rear of the chassis. The SSI E-bay 3.61-compliant chassis provides an ATX 2.2-compatible cutout for I/O shield installation. Boxed Intel® server boards provide the required I/O shield for installation in the cutout. The I/O cutout dimensions are shown in the following figure for reference.

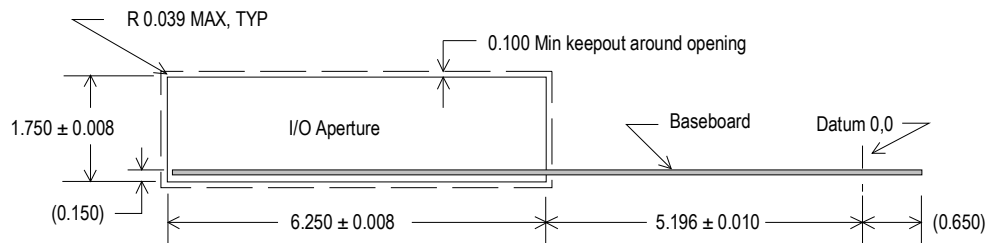
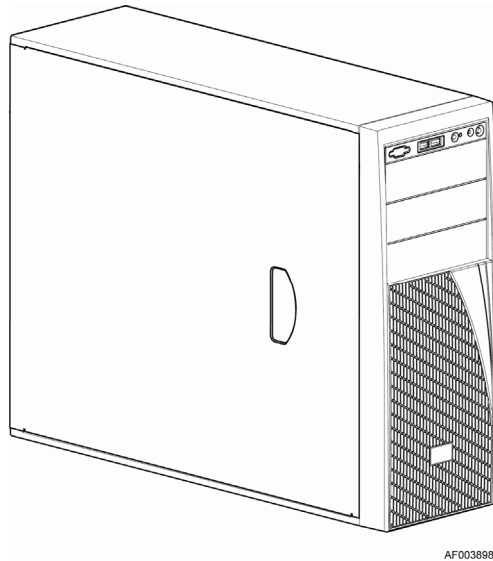

**Figure 3. ATX 2.2 I/O Aperture**

## 1.6 Front Bezel Features

There are two type of front bezel assembly in Intel® Server Chassis P4000S family.

- Front bezel assembly for fixed hard drives configuration



**Figure 4. Front Closed Chassis View with Front Bezel for Fixed Hard Drives Configuration**

- Front bezel assembly with the door for hot-swap hard drives configuration

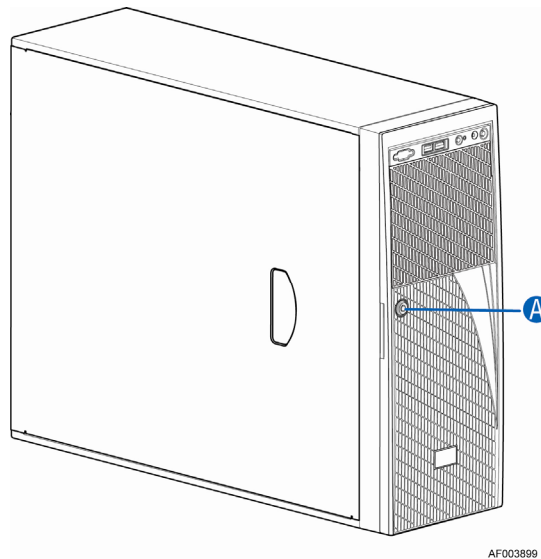

A. Security Lock

**Figure 5. Front Closed Chassis View with Front Bezel for Hot-swap Hard Drives Configuration**

Both two pedestal front bezel are constructed of molded plastic and attaches to the front of the chassis with three clips on the right side and two snaps on the left. The snaps at the left attach behind the access cover, thereby preventing accidental removal of the bezel. The bezel can

only be removed by first removing the server access cover. This provides additional security to the hard drive and peripheral bay area.

For the front bezel assembly for fixed hard drives configuration, removing the bezel, there is an EMI shield covering the fixed hard drives bay area.

For the front bezel assembly for hot-swap hard drives configuration, the bezel includes a key-locking door that covers the drive cage area and allows access to hot swap drives when a hot swap drive cage is installed.

The peripheral bays are covered with plastic snap-in cosmetic pieces that must be removed to add peripherals to the system. Front panel buttons and lights are located above the peripheral bays.

## 1.7 Standard Fixed Drive Trays

Intel® Server Chassis P4000S family supports four 3.5" fixed Hard Disk Drive trays. You can secure each of the four drives on the drive trays with screws, and install the drive trays in the chassis without a tool.

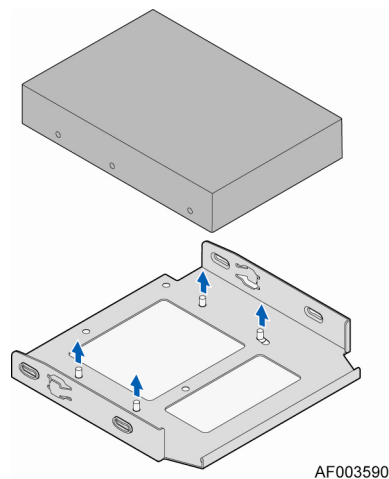
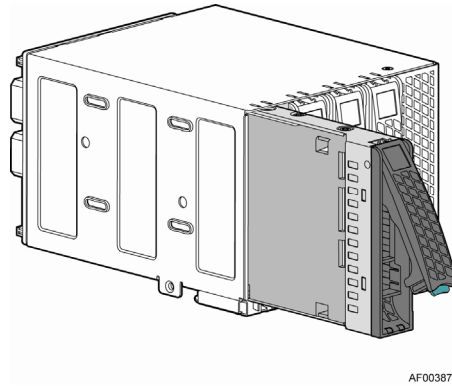

Figure 6. Fixed Drive Tray

## 1.8 4x3.5" Hot-Swap Hard Disk Drive Cage

The Intel® Server Chassis P4000S family supports 4x3.5" hot-swap hard drive cage, which can support up to four hot-swap hard drives.



AF003878

**Figure 7. 4x3.5" Hot-Swap Hard Disk Drive Cage**

### 1.8.1 3.5" Hot-swap Hard Drive Carrier

Each hard drive must be mounted to a hot-swap drive carrier, making insertion and extraction of the drive from the chassis very simple. Each drive carrier has its own dual-purpose latching mechanism used to both insert and extract drives from the chassis and lock the carrier in place. Each drive carrier supports a light pipe providing a drive status indicator, located on the backplane, to be viewable from the front of the chassis.

The 3.5" hot-swap hard drive carrier has a 2.5" HDD interface bracket pre-installed. The 2.5" HDD interface bracket is used for install the 2.5" hard drive on the 3.5" hot-swap hard drive carrier. When a 3.5" hard drive is to be installed, the 2.5" HDD interface bracket should be removed.

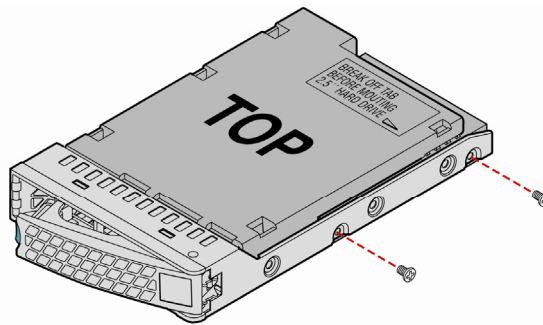

AF003879

**Figure 8. 3.5" hot-swap hard drive carrier with 2.5" HDD Interface Bracket**

## 1.9 Peripheral Bays

Three 5.25-in half-height drive bays are available for CD/DVD-ROM or tape drives as well as one 3.5-inch removable media drive bay. Drive installation is tool-less and requires no screws.

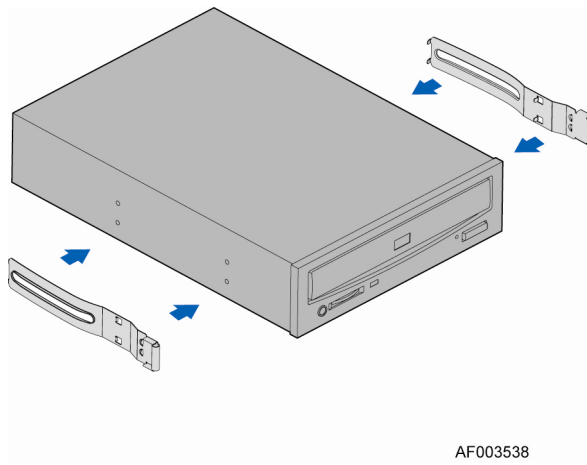

Figure 9. Tool-less Rails Mounting 5.25-inch CD-ROM Drive



## 2. Chassis Power Sub-system

---

### 2.1 365-W Power Supply

This 365-W power supply specification defines a non-redundant power supply that supports pedestal entry server systems. The 365W power supply has 6 outputs; 3.3V, 5V, 12V1, 12V2, -12V and 5Vsb. The power supply has an AC input and be power factor corrected.

#### 2.1.1 Mechanical Overview

The power supply size is 98mm x 150mm x 160mm (H x W x D) and has a wire harness for the DC outputs. The AC plugs directly into the external face of the power supply.

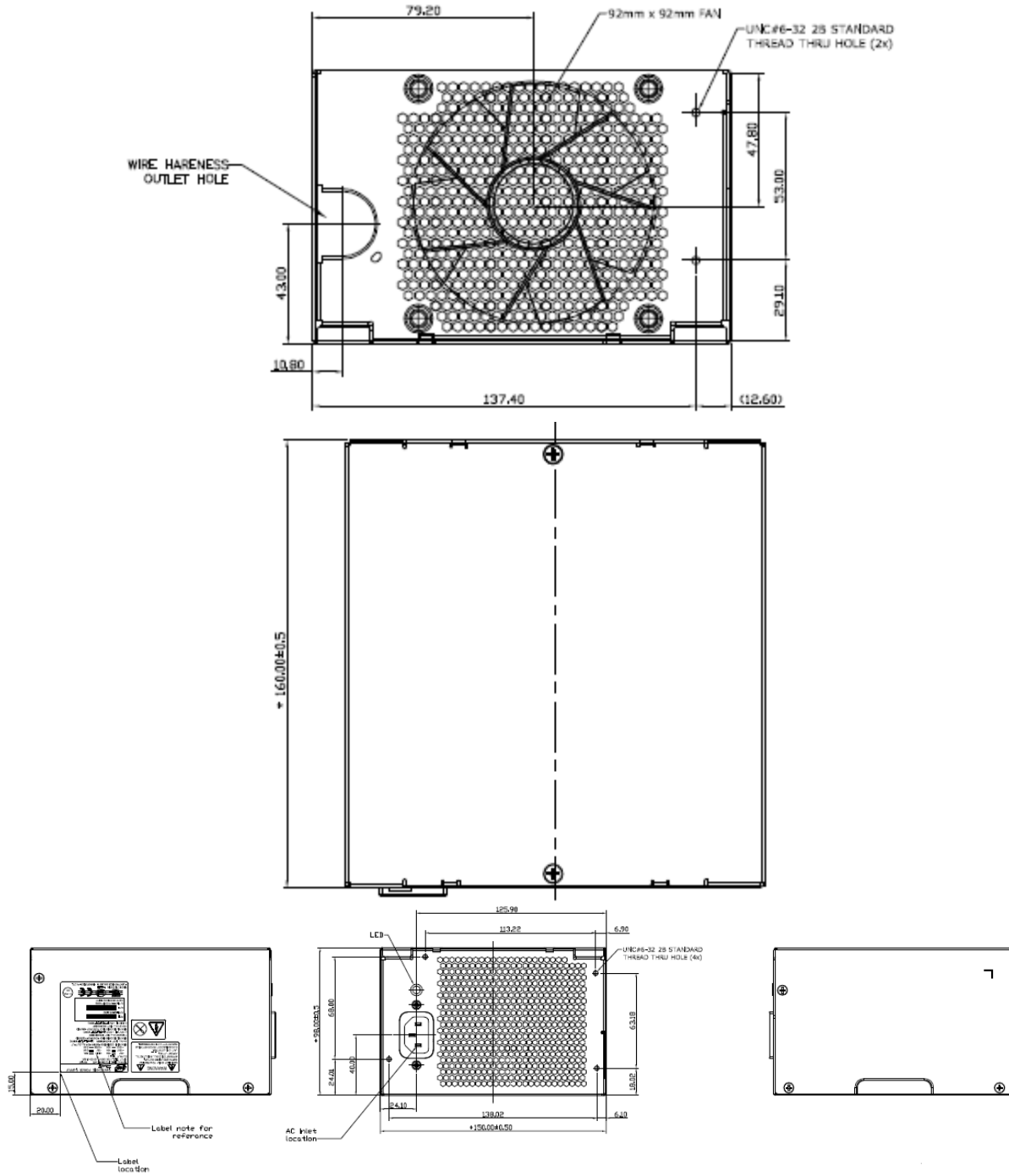

Figure 10. Mechanical Drawing for 365-W Power Supply Enclosure

### 2.1.2 365-W Power Supply Output Wire Harness

Listed or recognized component appliance wiring material (AVLV2), CN, rated min 85°C, 300VDC shall be used for all output wiring.

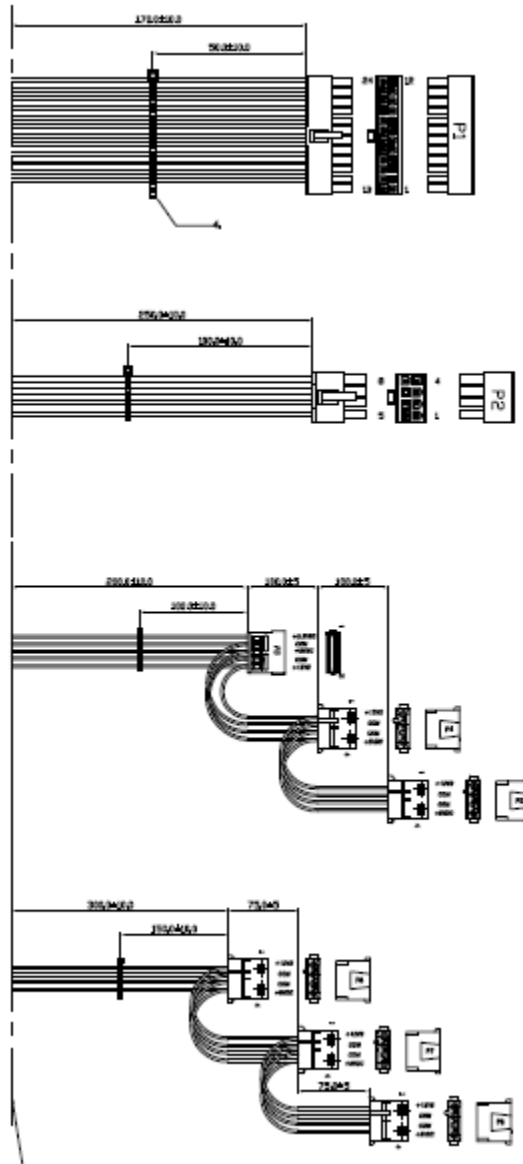

Figure 11. Output Cable Harness for 365-W Power Supply

**Table 2. 365-W Power Supply Cable Lengths**

From	Length (mm)	To connector #	No of pins	Description
Power Supply cover exit hole	170	P1	24	Baseboard Power Connector
Power Supply cover exit hole	250	P2	8	Processor Power Connector
Power Supply cover exit hole	200	P3	5	SATA Power Connector
Extension from P3	100	P4	4	Peripheral Power Connector
Extension from P4	100	P5	4	Peripheral Power Connector
Power Supply cover exit hole	300	P6	4	Peripheral Power Connector
Extension from P6	75	P7	4	Peripheral Power Connector
Extension from P7	75	P8	4	Peripheral Power Connector

### 2.1.2.1 Main power connector (P1)

Connector housing: 24- Pin Molex Mini-Fit Jr 39-01-2245 (94V2) or equivalent

Contact: Molex Minifit Jr, Crimp 5556 or equivalent

**Table 3. P1 Main Power Connector**

PIN	SIGNAL	18 AWG COLOR	PIN	SIGNAL	18 AWG COLOR
1	+3.3 VDC	Orange	13	+3.3 VDC	Orange
2	+3.3 VDC	Orange	14	-12 VDC	Blue
3	COM	Black	15	COM	Black
4	+5 VDC*	Red	16	PSON#	Green
5	COM	Black	17	COM	Black
6	+5 VDC	Red	18	COM	Black
7	COM	Black	19	COM	Black
8	PWR OK	Gray	20	Reserved	N.C.
9	5VSB	Purple	21	+5 VDC	Red
10	+12V2	Yellow/Black	22	+5 VDC	Red
11	+12V2	Yellow/Black	23	+5 VDC	Red
12	+3.3 VDC	Orange	24	COM	Black

### 2.1.2.2 Processor/Memory Power Connector (P2)

Connector housing: 8- Pin Molex 39-01-2085 (94V2) or equivalent

Contact: Molex, Mini-Fit Jr, HCS, 44476-1111 or equivalent

**Table 4. P2 Processor#1 Power Connector**

PIN	SIGNAL	18 AWG COLOR	PIN	SIGNAL	18 AWG COLOR
-----	--------	--------------	-----	--------	--------------

PIN	SIGNAL	18 AWG COLOR	PIN	SIGNAL	18 AWG COLOR
1	COM	Black	5	+12V1	Yellow
2	COM	Black	6	+12V1	Yellow
3	COM	Black	7	+12V1	Yellow
4	COM	Black	8	+12V1	Yellow

### 2.1.2.3 Peripheral Power Connectors (P4,5,6,7,8)

Connector housing: Amp 1-480424-0 or equivalent

Contact: Amp 61314-1 contact or equivalent

**Table 5. Peripheral Power Connectors**

Pin	Signal	18 AWG Color
1	+12V2	Yellow/Black
2	COM	Black
3	COM	Black
4	+5 VDC	Red

### 2.1.2.4 SATA Hard Drive Power Connectors (P3)

Connector housing: JWT A3811H00-5P (94V2) or equivalent;

Contact: JWT A3811TOP-0D or equivalent

**Table 6. SATA Power Connector**

Pin	Signal	18 AWG Color
1	+3.3V	Orange
2	COM	Black
3	+5VDC	Red
4	COM	Black
5	+12V2	Yellow/Black

## 2.1.3 Temperature Requirements

The power supply shall operate within all specified limits over the  $T_{op}$  temperature range.

**Table 7. Thermal Requirements**

ITEM	DESCRIPTION	MIN	MAX	UNITS
$T_{op}$	Operating temperature range.	0	50	°C
$T_{non-op}$	Non-operating temperature range.	-40	70	°C
Altitude	Maximum operating altitude.		3000	meters

## 2.1.4 AC Input Requirements

### 2.1.4.1 Power Factor

The power supply meets the power factor requirements stated in the Energy Star® Program Requirements for Computer Servers. These requirements are stated below.

**Table 8. Power Factor Requirements for Computer Servers**

Output power	20% load	50% load	100% load
Power factor	0.8	0.9	0.95

Tested at 230Vac, 50Hz and 60Hz and 115VAC, 60Hz.

Tested according to Generalized Internal Power Supply Efficiency Testing Protocol Rev 6.4.3.

This is posted at <http://efficientpowersupplies.epri.com/methods.asp>.

### 2.1.4.2 AC Inlet Connector

The AC input connector is an IEC 320 C-14 power inlet. This inlet is rated for 10A/250VAC.

### 2.1.4.3 AC Input Voltage Specification

The power supply operates within all specified limits over the following input voltage range. Harmonic distortion of up to 10% of the rated line voltage does not cause the power supply to go out of specified limits. Application of an input voltage below 85VAC does not cause damage to the power supply, including a blown fuse.

**Table 9. AC Input Voltage Range**

PARAMETER	MIN	RATED	VMAX	Start up VAC	Power Off VAC
Voltage (110)	90 V <sub>rms</sub>	100-127 V <sub>rms</sub>	140 V <sub>rms</sub>	85VAC +/- 4VAC	70VAC +/- 5VAC
Voltage (220)	180 V <sub>rms</sub>	200-240 V <sub>rms</sub>	264 V <sub>rms</sub>		
Frequency	47 Hz	50/60	63 Hz		

**Notes:**

1. Maximum input current at low input voltage range shall be measured at 90VAC, at max load.
2. Maximum input current at high input voltage range shall be measured at 180VAC, at max load.
3. This requirement is not to be used for determining agency input current markings.

### 2.1.4.4 AC Line Dropout/Holdup

An AC line dropout is defined to be when the AC input drops to 0VAC at any phase of the AC line for any length of time. During an AC dropout the power supply meets dynamic voltage regulation requirements. An AC line dropout of any duration does not cause tripping of control signals or protection circuits. If the AC dropout lasts longer than the hold up time the power supply recovers and meets all turn on requirements. The power supply meets the AC dropout requirement over rated AC voltages and frequencies. A dropout of the AC line for any duration does not cause damage to the power supply.

**Table 10. AC Line Holdup Time**

Loading	Holdup time
75%	12msec

### 2.1.4.5 AC Line Fuse

The power supply has one line fused in the **single line fuse** on the line (Hot) wire of the AC input. The line fusing is acceptable for all safety agency requirements. The input fuse is a slow blow type. AC inrush current does not cause the AC line fuse to blow under any conditions. All protection circuits in the power supply do not cause the AC fuse to blow unless a component in the power supply has failed. This includes DC output load short conditions.

### 2.1.4.6 AC Line Leakage Current

The maximum leakage current to ground for each power supply is 3.5mA when tested at 240VAC

### 2.1.4.7 AC Line Transient Specification

AC line transient conditions are defined as “sag” and “surge” conditions. “Sag” conditions are also commonly referred to as “brownout”, these conditions is defined as the AC line voltage dropping below nominal voltage conditions. “Surge” is defined to refer to conditions when the AC line voltage rises above nominal voltage.

The power supply meets the requirements under the following AC line sag and surge conditions.

**Table 11. AC Line Sag Transient Performance**

AC Line Sag (10sec interval between each sagging)				
Duration	Sag	Operating AC Voltage	Line Frequency	Performance Criteria
0 to 1/2 AC cycle	95%	Nominal AC Voltage ranges	50/60Hz	No loss of function or performance
> 1 AC cycle	>30 %	Nominal AC Voltage ranges	50/60Hz	Loss of function acceptable, self recoverable

**Table 12. AC Line Surge Transient Performance**

AC Line Surge				
Duration	Surge	Operating AC Voltage	Line Frequency	Performance Criteria
Continuous	10%	Nominal AC Voltages	50/60Hz	No loss of function or performance
0 to 1/2 AC cycle	30%	Mid-point of nominal AC Voltages	50/60Hz	No loss of function or performance

### 2.1.4.8 Power Recovery

The power supply recovers automatically after an AC power failure. AC power failure is defined to be any loss of AC power that exceeds the dropout criteria.

### 2.1.5 Efficiency

The following table provides the required minimum efficiency level at various loading conditions. These are provided at three different load levels; 100%, 50% and 20%. Output shall be load according to the proportional loading method defined by 80 Plus in Generalized Internal Power Supply Efficiency Testing Protocol Rev 6.4.3. This is posted at

<http://efficientpowersupplies.epri.com/methods.asp>.

**Table 13. Silver Efficiency Requirement**

Loading	100% of maximum	50% of maximum	20% of maximum
Minimum Efficiency	85%	88%	85%

The power supply passes with enough margins to make sure in production all power supplies meet these efficiency requirements.

### 2.1.5.1 Standby Efficiency

When in standby mode; the power supply draws less than 1W AC power with 100mA of 5V standby load. This shall be tested at 115VAC/60Hz and 230VAC/50Hz

## 2.1.6 DC Output Specification

### 2.1.6.1 Output Power/Currents

The following table defines the minimum power and current ratings. The power supply meets both static and dynamic voltage regulation requirements for all conditions.

**Table 14. Over Voltage Protection Limits**

Parameter	Min	Max.	Peak	Unit
5V	0.3	10.0		A
12V1	0.7	16.0	18.0	A
12V2	1.5	16.0	18.0	A
3.3V	0.5	18.0		A
- 12V	0.0	0.5		A
5Vstby	0.0	2.5	3.0	A

**Notes:**

1. Max combined power for all output shall not exceed 365W.
2. Peak combined power for all outputs shall not exceed 385W.
3. Max combined power of 12V1 and 12V2 shall not exceed 318W.
4. Max combined power on 3.3V and 5V shall not exceed 80W.

Peak power and current loading shall be supported for a minimum of 12 second

### 2.1.6.2 Cross Loading

The power supply maintains voltage regulation limit when operated over the following cross loading conditions.

**Table 15. Loading Conditions**

	3.3V	5.0V	12.0V	12.0V	12.0V	5.0V	Total Power	12V Power	3.3V/5V Power
Load1	10.8	2	16	10.5	0	0.3	365	318	46
Load2	18	4.1	7.6	16	0	0.3	365	283	80



	3.3V	5.0V	12.0V	12.0V	12.0V	5.0V	Total Power	12V Power	3.3V/5V Power
Load3	18	4.1	16	7.6	0	0.3	365	283	80
Load4	13.6	7	10.2	12	0.5	2.5	365	266	80
Load5	0.5	0.3	0.7	1.5	0	0.3	31	26	3
Load6	16	4	0.7	2.6	0	0.3	114	40	73
Load7	1.2	2.7	14.5	7.1	0	1	282	259	17

### 2.1.6.3 Standby Output

The 5VSB output is present when an AC input greater than the power supply turn on voltage is applied.

### 2.1.6.4 Voltage Regulation

The power supply output voltages stay within the following voltage limits when operating at steady state and dynamic loading conditions. These limits include the peak-peak ripple/noise. These shall be measured at the output connectors

**Table 16. Voltage Regulation Limits**

PARAMETER	TOLERANCE	MIN	NOM	MAX	UNITS
+3.3V	- 5%/+5%	+3.14	+3.30	+3.46	V <sub>rms</sub>
+5V	- 5%/+5%	+4.75	+5.00	+5.25	V <sub>rms</sub>
+12V1	- 5%/+5%	+11.40	+12.00	+12.60	V <sub>rms</sub>
+12V2	- 5%/+5%	+11.40	+12.00	+12.60	V <sub>rms</sub>
- 12V	- 10%/+10%	- 13.20	-12.00	-10.80	V <sub>rms</sub>
+5VSB	- 5%/+5%	+4.75	+5.00	+5.25	V <sub>rms</sub>

### 2.1.6.5 Dynamic Loading

The output voltages remain within limits specified for the step loading and capacitive loading specified in the table below. The load transient repetition rate is tested between 50Hz and 5kHz at duty cycles ranging from 10%-90%. The load transient repetition rate is only a test specification. The  $\Delta$  step load may occur anywhere within the MIN load to the MAX load conditions.

**Table 17. Transient Load Requirements**

Output	$\Delta$ Step Load Size (See note 2)	Load Slew Rate	Test capacitive Load
+3.3V	6.0A	0.5 A/ $\mu$ sec	970 $\mu$ F
+5V	4.0A	0.5 A/ $\mu$ sec	400 $\mu$ F
12V1+12V2	18.0A	0.5 A/ $\mu$ sec	2200 $\mu$ F <sup>1,2</sup>
+5VSB	0.5A	0.5 A/ $\mu$ sec	20 $\mu$ F

**Notes:**

1. Step loads on each 12V output may happen **simultaneously**.
2. The +12V should be tested with 2200 $\mu$ F evenly split between the four +12V rails
3. This will be tested over the range of load conditions in section 2.1.6.2.

### 2.1.6.6 Capacitive Loading

The power supply is stable and meets all requirements with the following capacitive loading ranges.

**Table 18. Capacitive Loading Conditions**

Output	MIN	MAX	Units
+3.3V	250	5000	μF
+5V	400	5000	μF
+12V	500	8000	μF
-12V	1	350	μF
+5VSB	20	350	μF

### 2.1.6.7 Grounding

The output ground of the pins of the power supply provides the output power return path. The output connector ground pins are connected to the safety ground (power supply enclosure). This grounding is well designed to ensure passing the max allowed Common Mode Noise levels.

The power supply is provided with a reliable protective earth ground. All secondary circuits are connected to protective earth ground. Resistance of the ground returns to chassis does not exceed 1.0 mΩ. This path may be used to carry DC current.

### 2.1.6.8 Residual Voltage Immunity in Standby mode

The power supply is immune to any residual voltage placed on its outputs (Typically a leakage voltage through the system from standby output) up to **500mV**. There is neither additional heat generated, nor stressing of any internal components with this voltage applied to any individual or all outputs simultaneously. It also does not trip the protection circuits during turn on.

The residual voltage at the power supply outputs for no load condition does not exceed **100mV** when AC voltage is applied and the PSON# signal is de-asserted.

### 2.1.6.9 Common Mode Noise

The Common Mode noise on any output does not exceed **350mV pk-pk** over the frequency band of 10Hz to 20MHz.

The measurement is made across a 100Ω resistor between each of DC outputs, including ground at the DC power connector and chassis ground (power subsystem enclosure).

The test set-up shall use a FET probe such as Tektronix model P6046 or equivalent.

### 2.1.6.10 Ripple/Noise

The maximum allowed ripple/noise output of the power supply is defined in below Table 19. This is measured over a bandwidth of 10Hz to 20MHz at the power supply output connectors. A 10μF tantalum capacitor in parallel with a 0.1μF ceramic capacitor is placed at the point of measurement.

Table 19. Ripples and Noise

+3.3V	+5V	+12V 1	+12V 2	-12V	+5VSB
50mVp-p	50mVp-p	120mVp-p	120mVp-p	200mVp-p	50mVp-p

The test set-up shall be as shown below.

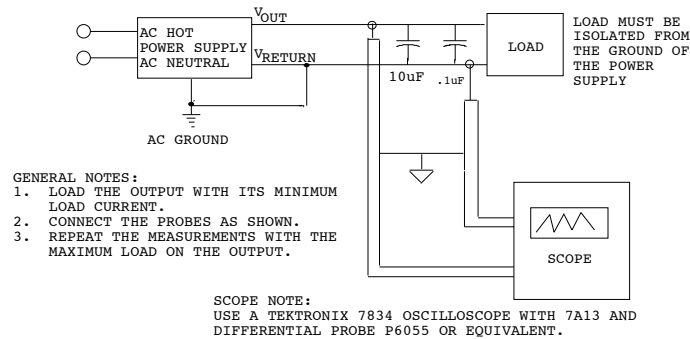

Figure 12. Differential Noise test setup

**Note:** When performing this test, the probe clips and capacitors should be located close to the load.

### 2.1.6.11 Timing Requirements

These are the timing requirements for the power supply operation. The output voltages rise from 10% to within regulation limits ( $T_{vout\_rise}$ ) within 2 to 50ms, except for 5VSB - it is allowed to rise from 1 to 25ms. The +3.3V, +5V and +12V1, +12V2 output voltages should start to rise approximately at the same time. **All outputs must rise monotonically.** Each output voltage reach regulation within 50ms ( $T_{vout\_on}$ ) of each other during turn on the power supply. Each output voltage fall out of regulation within 400ms ( $T_{vout\_off}$ ) of each other during turn off. Table 21 shows the timing requirements for the power supply being turned on and off via the AC input, with PSON held low and the PSON signal, with the AC input applied.

Table 20. Output Voltage Timing

Item	Description	MIN	MAX	UNITS
$T_{vout\_rise}$	Output voltage rise time from each main output.	2	50	ms
	Output rise time for the 5Vstby output.	1	25	ms
$T_{vout\_on}$	All main outputs must be within regulation of each other within this time.		50	ms
$T_{vout\_off}$	All main outputs must leave regulation within this time.		400	ms

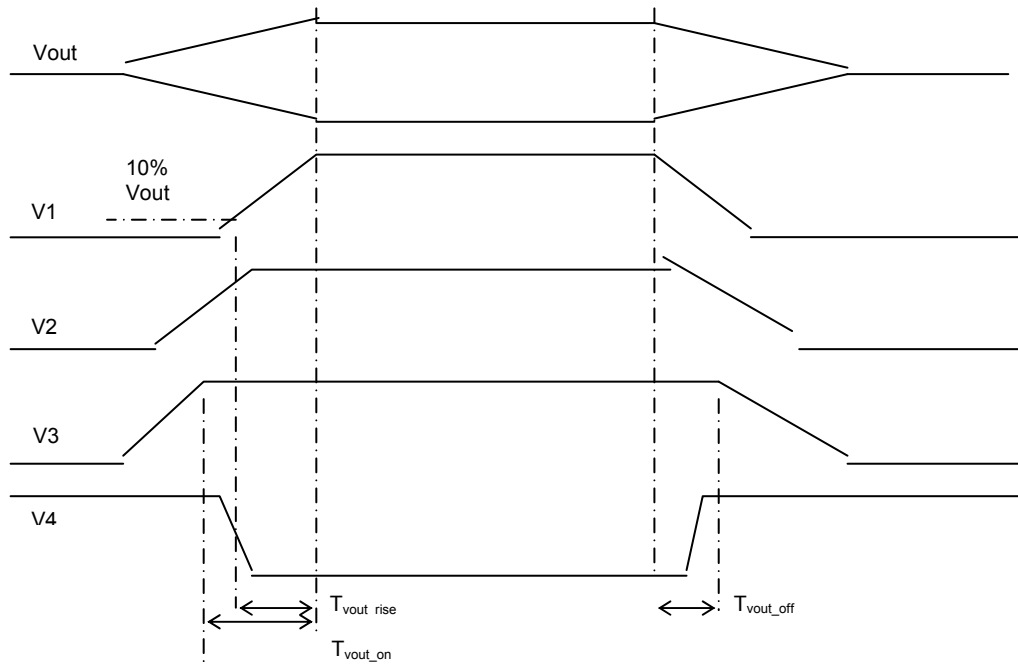
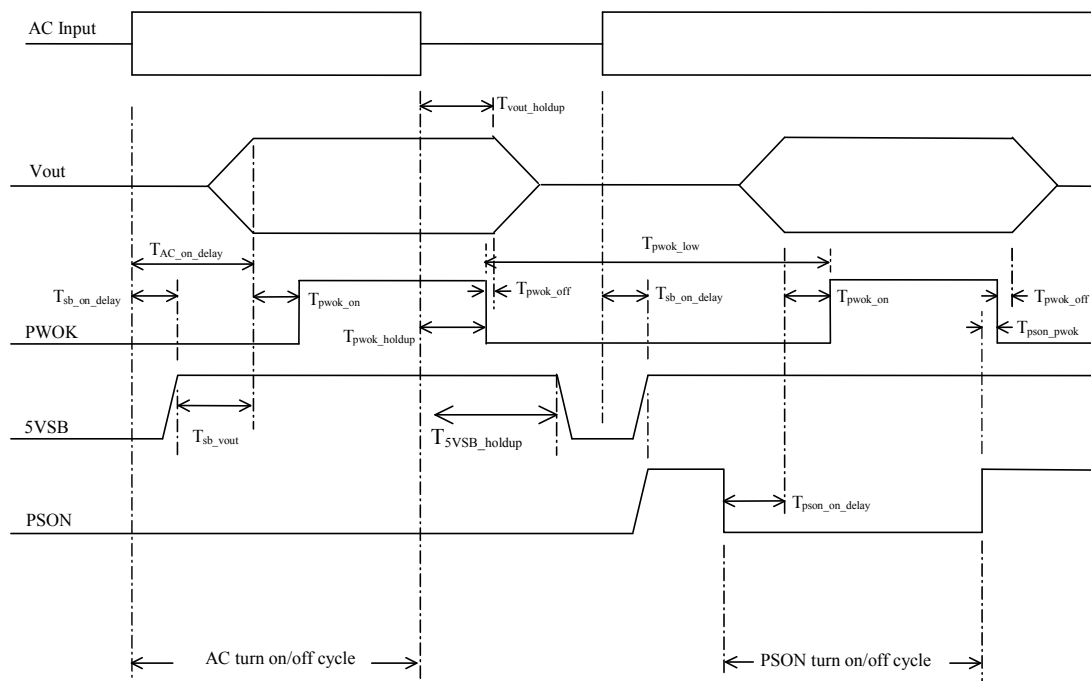

Figure 13. Output Voltage Timing

**Table 21. Turn On/Off Timing**

Item	Description	Min.	Max.	Units
$T_{sb\_on\_delay}$	Delay from AC being applied to 5VSB being within regulation.		1500	ms
$T_{ac\_on\_delay}$	Delay from AC being applied to all output voltages being within regulation.		2500	ms
$T_{vout\_holdup}$	Time all output voltages stay within regulation after loss of AC. Tested at 75% of maximum load.	13		ms
$T_{pwok\_holdup}$	Delay from loss of AC to de-assertion of PWOK. Tested at 75% of maximum load.	12		ms
$T_{pson\_on\_delay}$	Delay from PSON# active to output voltages within regulation limits.	5	400	ms
$T_{pson\_pwok}$	Delay from PSON# deactivate to PWOK being de-asserted.		50	ms
$T_{pwok\_on}$	Delay from output voltages within regulation limits to PWOK asserted at turn on.	100	500	ms
$T_{pwok\_off}$	Delay from PWOK de-asserted to output voltages (3.3V, 5V, 12V, -12V) dropping out of regulation limits.	1		ms
$T_{pwok\_low}$	Duration of PWOK being in the de-asserted state during an off/on cycle using AC or the PSON signal.	100		ms
$T_{sb\_vout}$	Delay from 5VSB being in regulation to O/Ps being in regulation at AC turn on.	10	1000	ms
$T_{5VSB\_holdup}$	Time the 5VSB output voltage stays within regulation after loss of AC.	70		ms



**Figure 14. Turn On/Off Timing (Power Supply Signals)**

## 2.1.7 Protection Circuits

Protection circuits inside the power supply causes only the power supply's main outputs to shutdown. If the power supply latches off due to a protection circuit tripping, an AC cycle OFF for 15sec and a PSON# cycle HIGH for 1sec able to reset the power supply.

### 2.1.7.1 Current Limit (OCP)

Overload currents applied to each tested output rail will cause the output to trip before they reach or exceed 240 VA. If the current limits are exceeded the power supply shuts down and latches off. The latch will be cleared by toggling the PSON# signal or by an AC power interruption. The power supply does not be damaged from repeated power cycling in this condition. -12V and 5VSB is protected under over current or shorted conditions so that no damage can occur to the power supply. 5Vsb will be auto-recovered after removing OCP limit.

### 2.1.7.2 Over Voltage Protection (OVP)

The power supply over voltage protection is locally sensed. The power supply shuts down and latches off after an over voltage condition occurs. This latch is cleared by toggling the PSON# signal or by an AC power interruption. Below Table 22 contains the over voltage limits. The values are measured at the output of the power supply's pins. The voltage shall never exceed the maximum levels when measured at the power pins of the power supply connector during any single point of fail. The voltage shall never trip any lower than the minimum levels when measured at the power pins of the power supply connector. 5Vsb will be auto-recovered after removing OVP limit.

**Table 22. Over Voltage Protection (OVP) Limits**

Output Voltage	MAX (V)
+3.3V	4.5
+5V	6.5
+12V1,2	14.5
+5VSB	6.5

### 2.1.7.3 Over Temperature Protection (OTP)

The power supply will be protected against over temperature conditions caused by loss of fan cooling or excessive ambient temperature. In an OTP condition the PSU will shutdown.

## 2.1.8 Control and Indicator Functions

The following sections define the input and output signals from the power supply. Signals that can be defined as low true use the following convention: Signal# = low true

### 2.1.8.1 PSON# Input Signal

The PSON# signal is required to remotely turn on/off the power supply. PSON# is an active low signal that turns on the +3.3V, +5V, +12V1, +12V2 and -12V power rails. When this signal is not pulled low by the system, or left open, the outputs (except the +5VSB) turn off. This signal is pulled to a standby voltage by a pull-up resistor internal to the power supply. Refer Figure 14 for the timing diagram.

Table 23. PSON# Signal Characteristic

Signal Type	Accepts an open collector/drain input from the system. Pull-up to VSB located in power supply.	
PSON# = Low	ON	
PSON# = High or Open	OFF	
	MIN	MAX
Logic level low (power supply ON)	0V	1.0V
Logic level high (power supply OFF)	2.0V	5.25V
Source current, Vpson = low		4mA
Power up delay: T <sub>pson_on_delay</sub>	5msec	400msec
PWOK delay: T <sub>pson_pwok</sub>		50msec

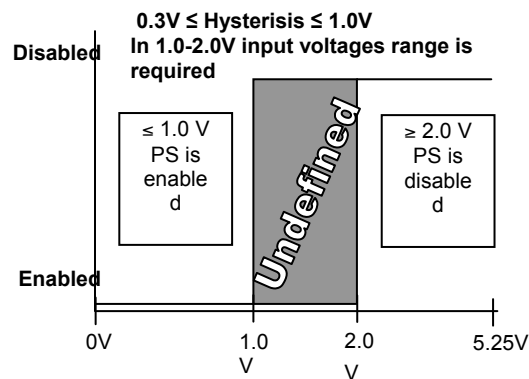

Figure 15. PSON# Required Signal Characteristic

### 2.1.8.2 PWOK (Power OK) Output Signal

PWOK is a power OK signal and will be pulled HIGH by the power supply to indicate that all the outputs are within the regulation limits of the power supply. When any output voltage falls below regulation limits or when AC power has been removed for a time sufficiently long so that power supply operation is no longer guaranteed, PWOK will be de-asserted to a LOW state. See below table for a representation of the timing characteristics of PWOK. The start of the PWOK delay time shall inhibited as long as any power supply output is in current limit.

Table 24. PWOK Signal Characteristics

Signal Type	Open collector/drain output from power supply. Pull-up to VSB located in system.	
PWOK = High	Power OK	
PWOK = Low	Power Not OK	
	MIN	MAX
Logic level low voltage, Isink=4mA	0V	0.4V
Logic level high voltage, Isource=200μA	2.4V	5.25V
Sink current, PWOK = low		4mA
Source current, PWOK = high		2mA
PWOK delay: T <sub>pwok_on</sub>	100ms	500ms

Signal Type	Open collector/drain output from power supply. Pull-up to VSB located in system.	
PWOK = High	Power OK	
PWOK = Low	Power Not OK	
	MIN	MAX
PWOK rise and fall time		100µsec
Power down delay: T pwok_off	1ms	



## 3. Chassis Cooling

---

The Intel® Server Chassis P4000S family is engineered to provide sufficient cooling for all internal components of the server. The cooling subsystem is dependent upon proper airflow. The designated cooling vents on both the front and back of the chassis must be left open and must not be blocked by improperly installed devices. All internal cables must be routed in a manner that does not impede airflow, and ducting provided for CPU cooling must be installed.

### 3.1 Cooling solution for Intel® Server Board S1200BT Series

The cooling solution for Intel® Server Board S1200BT series in Intel® Server Chassis P4000S family consists of one 92x38 mm rear system fan and one power supply fan. The 4-wire/4-pin 92mm x 38mm system fan is designed to plug into a 4-pin SSI fan headers, provides cooling at the rear of the chassis by drawing fresh air into the chassis from the front and exhausting warm air out the system.

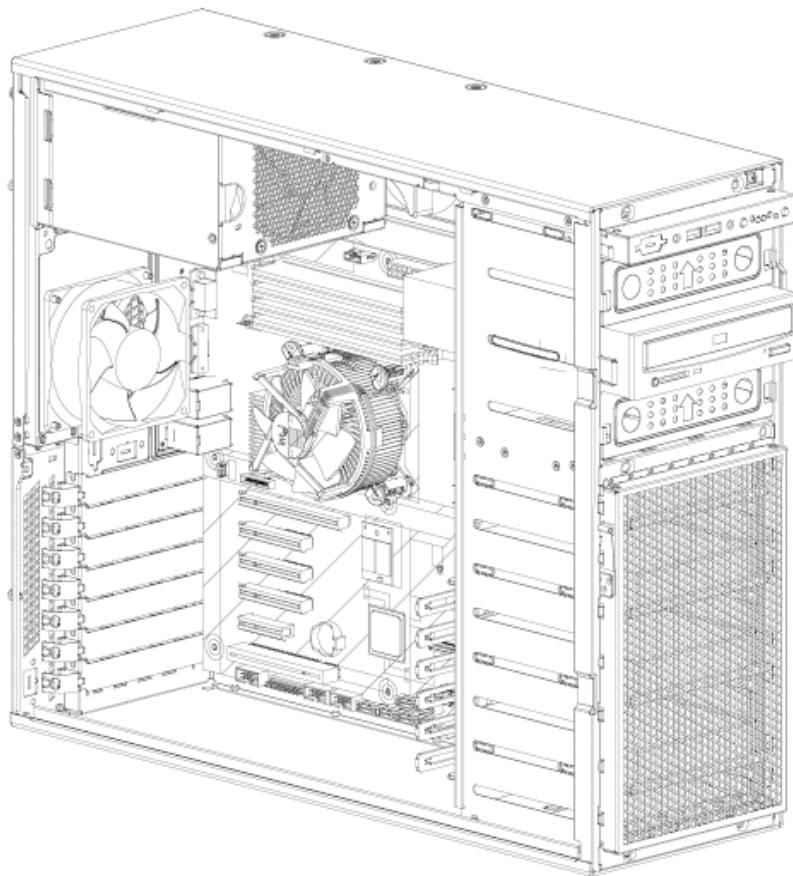

**Figure 16. Active Heat Sink and Chassis Rear Fan in Intel® Server Chassis P4304XXSFCN**

The power supply fan assists in drawing air through the peripheral bay area, through the power supply and exhausting it out the rear of the chassis.

## 3.2 Server Board Fan Control

The fans provided in the Intel® Server Chassis P4000S Family contains a tachometer signal that can be monitored by the server management subsystem of the Intel® Server Boards for RPM (Revolutions per Minute) detection.

The server board monitors several temperature sensors and adjusts the PWM (Pulse Width Modulated) signal to drive the fan at the appropriate speed.

The front panel of the chassis has a digital temperature sensor connected to the server board through the front panel's bus. The server board firmware adjusts the fan speed based on the front panel intake temperature and processor temperatures.

Refer to the baseboard documentation for additional details on how fan control is implemented.

## 3.3 Fan Header Connector Descriptions

All system fan headers support pulse width modulated (PWM) fans for cooling the processors in the chassis. PWM fans have an improved RPM range (20% to 100% rated fan speed) when compared to voltage controlled fans.

The fixed chassis fans are a 4-wire/4-pin style designed to plug into 4-pin or 6-pin SSI Fan headers. When plugged into a 6-pin header, only the first four signals are used (Pwr, Gnd, Tach, PWM).

## 4. Standard Front Panel

---

### 4.1 Front Panel Overview

The Front Panel will be used for Intel® Server Board S1200BTL, S1200BTS and other platforms. It is a common front panel across different server boards and systems.

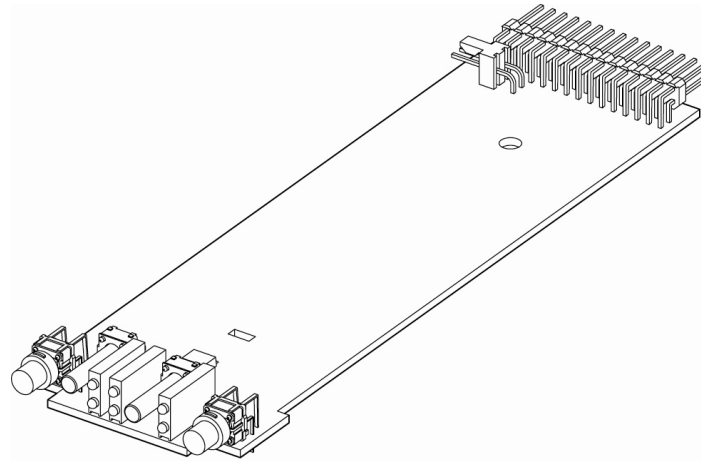

AF003625

**Figure 17. Front Panel overview**

This front panel conforms to SSI specification with one exception that up to 4 LAN act/link LEDs are supported. The common front panel can support either the standard SSI 2x12 cable interconnect (2 LAN ports) or an EPSD customized 2x15 cable interconnect (4 LAN ports). With Intel® Server Board S1200BT, the front panel supports standard SSI specification by using the standard SSI 2X 12 cables

### 4.2 Front Panel Features

The Front panel has the following features:

- Power button with integrated power LED (green).
- Chassis ID button with integrated ID LED (blue).
- Status/Fault LED (green/amber) (Conform to the BT board).
- Reset button.
- Global HDD activity LED (One HDD action).
- 4 LAN activity/link LEDs (Intel® Server Board S1200BT is using 2 LAN LEDs, such as NIC\_1\_LED and NIC\_2\_LED).
- NMI button
- Connectors: RA 2x15pin signal connector (supports 2x12pin SSI FP connections) and SSI 1x2pin chassis intrusion.

### 4.3 Common Front Panel Placement

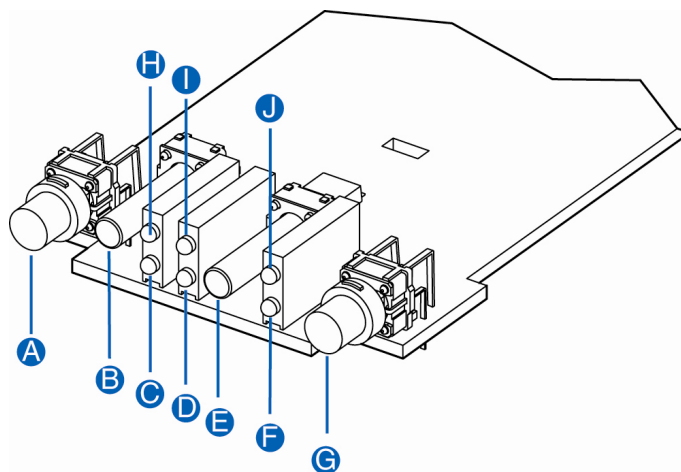

AF003626

	Description		Description
A	Unstuffable ID Button with ID LED	F	Status/Fault LED
B	NMI Button	G	Power Button with power LED
C	LAN1 LED	H	LAN2 LED
D	LAN3 LED	I	LAN4 LED
E	Reset Button	J	HDD activity LED

Figure 18. Common Front Panel LED/Button Arrangement

#### 4.3.1 Common Front Panel LED Functionality

Table 25. Front Panel LED Functionality

LED	Color	Condition	What It Means
Power/Sleep	Green	On	Power on or S0 sleep.
	Green	Blink	S1 sleep or S3 standby only for workstation baseboards.
		Off	Off (also sleep S4/S5 modes).
Status	Green	On	System ready/No alarm.
	Green	Blink	System ready, but degraded: redundancy lost such as PS or fan failure; non-critical temp/voltage threshold; battery failure; or predictive PS failure.
	Amber	On	Critical alarm: Voltage, thermal, or power fault; CPU missing; insufficient power unit redundancy resource offset asserted.
	Amber	Blink	Non-Critical failure: Critical temp/voltage threshold; VDR hot asserted; min number fans not present or failed.

LED	Color	Condition	What It Means
		Off	AC power off: System unplugged. AC power on: System powered off and in standby, no prior degraded\non-critical\critical state.
Global HDD Activity	Green	Blink	HDD access.
		Off	No access and no fault.
LAN 1-4 Activity/Link (LAN 1-2 for Intel® Server Board S1200BT)	Green	On	LAN link/no access.
	Green	Blink	LAN access.
		Off	Idle.
Chassis Identification	Blue	On	Front panel chassis ID button pressed.
	Blue	Blink	Unit selected for identification via software.
		Off	No identification.

**Note:** This is dependent on server board support. Not all server boards support all features. For additional details about control panel functions supported for a specific board, refer to the individual server board specifications.

## 4.4 Common Front Panel Connector List & Pinouts

Below is a list of the connectors needed for this board.

**Table 26. Connectors for Boards**

Function	Qty
RA 2x15 FP	1
RA 1x2 Chassis Intrusion	1

### 4.4.1 Pinouts

The following table describes the pinouts:

**Table 27. Pinouts Signal Description**

Pin	Signal Description	Pin	Signal Description
1	Power LED Anode	2	Front Plane Power (P3V3_STBY)
3	Key Pin	4	System ID LED Anode
5	Power LED Cathode	6	System ID LED Cathode
7	HDD Activity LED Anode	8	System status LED1 Cathode (Green)
9	HDD Activity LED Cathode	10	System status LED2 Cathode (Amber)

Pin	Signal Description	Pin	Signal Description
11	Power Switch	12	NIC_1 Activity LED Anode
13	Power Switch (GND)	14	NIC_1 Activity LED Cathode
15	Reset Switch	16	SMBus SDA
17	Reset Switch (GND)	18	SMBus SCL
19	System ID Switch	20	Chassis Intrusion
21	1-wire Temp Sensor (unused)	22	NIC_2 Activity LED Anode
23	NMI to CPU Switch	24	NIC_2 Activity LED Cathode
25	Key Pin	26	Key Pin
27	NIC_3 Activity LED Anode	28	NIC_4 Activity LED Anode
29	NIC_3 Activity LED Cathode	30	NIC_4 Activity LED Cathode

**Note:** Pin 1~24 is compatible with SSI spec.

**Table 28. Chassis Intrusion Pin-out**

Description	
RA 1x2 Chassis Intrusion	
Pin	Signal Description
1	FP_CHASSIS_INTRU
2	GND

## 5. 4x3.5" Hot-Swap Back Plane (HSBP)

---

### 5.1 Overview

The Chassis supports 4x3.5" SAS/SATA backplane. The backplane provide the platform support for up to four hot-swap SAS or SATA hard drives.

#### 5.1.1 Key Features

The 4HDD SAS/SATA HSBP supports the following feature set:

- 4x SAS/SATA 3.5" hot swap hard drive at 6Gb SAS/SATA or slower speeds.
- One SGPIO SFF-8485 interface from a 5pin connector.
- One I2C interface from a 5pin connector for HDD status communication to BMC over slave SMB bus.
- Temperature sensor and FRU support
- In-application FW updateable over I2C interfaces via BMC. No special hardware needed for field FW upgrade with BMC onboard EPSD baseboard
- 4 HDD status LEDs and 4 HDD activity LEDs
- 4 HDD presence detect inputs to the microcontroller
- 3.3V linear regulator for to power microcontroller and various other components
- Four 7pin shrouded latching THMT SAS/SATA input connectors
- 29pin SAS/SATA 'hybrid' docking hotswap connectors

#### 5.1.2 Board Layout

The following figure shows the board layout and connectors placement of the 4HDD SAS/SATA hot-swap backplane

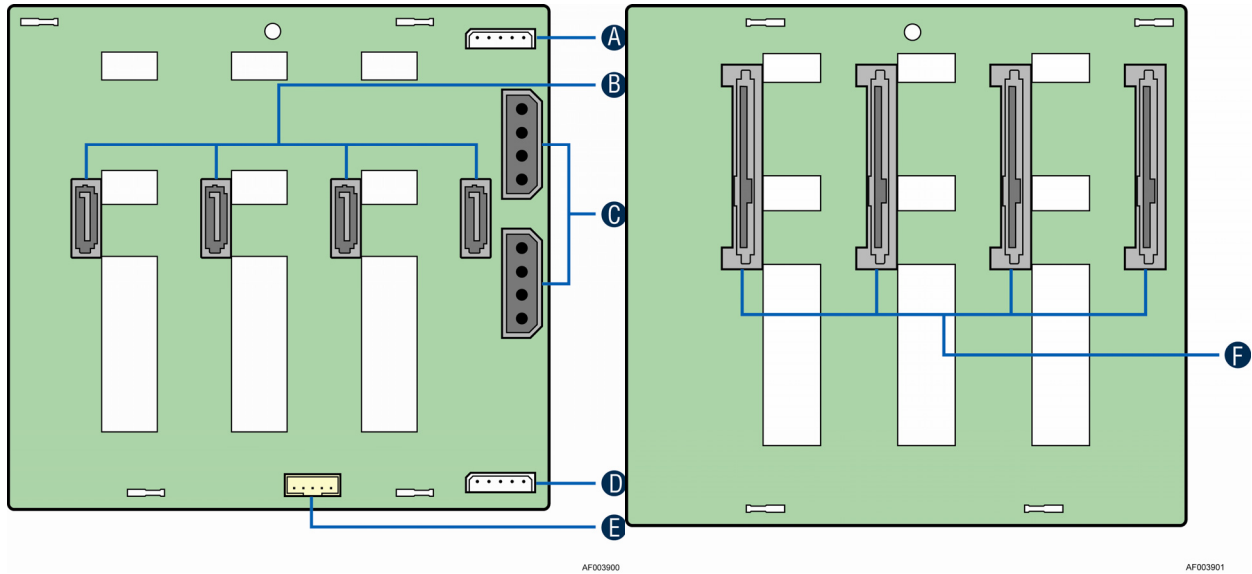

- A. I2C\_In Connectors
- B. SATA/SAS Cable Connctors
- C. Power Connectors
- D. I2C\_Out Connectors
- E. SGPIO connector
- F. SATA/SAS Hot-swap Drive Connectors

**Figure 19. 8x3.5" HSBP Board Layout**

---

**Note:** Secondary side is mirrored. FW\_UPDT Connector is for debug purpose during development phase. It will be depoped in mass-production.

---

## 5.2 4x 3.5" HSBP Functional Description

### 5.2.1 4x3.5" HSBP Microcontroller

The microcontroller Cypress PSoC (CY8C22545-24AXI) is sized for 4x and 8x HSBP. It includes I2C interface hardware for in application updating of FW operational code via I2C interface.

Below is the microcontroller singal names and pin numbers

**Table 29. 4x3.5" HSBP Microcontroller Pinouts**

Pin	Pin Name	Signal Name
1	P2[5]	FM_HDD_PRSNT1
2	P2[3]	SGPIO_DATAOUT_0
3	P2[1]	SGPIO_DATAIN_0
4	Vdd	P3V3
5	P4[5]	TP_SATA_6X_MODE



Pin	Pin Name	Signal Name
6	P4[3]	LED_HDD_FAULT3_N
7	P4[1]	LED_HDD_FAULT1_N
8	Vss	GND
9	P3[7]	TP_SGPIO_DATAOUT_1
10	P3[5]	TP_SGPIO_DATAIN_1
11	P3[3]	TP_HDD_PRSENT_7
12	P3[1]	TP_HDD_PRSENT_5
13	P1[7]	SMB_P3V3_CLK
14	P1[5]	SMB_P3V3_DAT
15	P1[3]	TP_P1_3
16	P1[1]	SMB_ISSP_CLK
17	Vss	GND
18	P1[0]	SMB_ISSP_DAT
19	P1[2]	TP_P1_2
20	P1[4]	SMB_ADD0
21	P1[6]	SMB_ADD1
22	P3[0]	TP_HDD_PRSENT_4
23	P3[2]	TP_HDD_PRSENT_6
24	P3[4]	TP_SGPIO_CLK_1
25	P3[6]	TP_SGPIO_LOAD_1
26	XRES	FM_ISSP_XRES
27	P4[0]	LED_HDD_FAULT0_N
28	P4[2]	LED_HDD_FAULT2_N
29	P4[4]	TP_P4_4
30	Vss	GND
31	P2[0]	SGPIO_CLOCK_0
32	P2[2]	SGPIO_LOAD_0
33	P2[4]	FM_HDD_PRSENT0
34	P2[6]	FM_HDD_PRSENT2
35	P0[0]	Therm_P0
36	P0[2]	TP_THERM_N
37	P0[4]	TP_LED_HDD_FAULT4_N
38	P0[6]	TP_LED_HDD_FAULT6_N
39	Vdd	P3V3
40	P0[7]	TP_LED_HDD_FAULT7_N
41	P0[5]	TP_LED_HDD_FAULT5_N
42	P0[3]	TP_P0_3
43	P0[1]	TP_P0_1
44	P2[7]	FM_HDD_PRSENT3

### 5.2.2 SGPIO Functionality

The 4x 3.5" HSBP supports a SFF-8485 compliant SGPIO interface. It is used to activate the HDD status LED as well is monitored by the microcontroller for generating fault, identify, &

rebuild registers that in turn are monitored by the baseboard BMC for generating corresponding SEL events.

SGPIO uses a 5pin header; this is to incorporate a ground conductor as an SI improvement over previous generation products and based on measurement data indicating add the ground is strongly recommended. The 5pin connector will be consistent with other HSBPs, in this way cable commonality is improved.

### 5.2.3 I2C Functionality

The microcontroller has a master/slave I2C connection to the baseboard BMC. The microcontroller is not an IPMB compliant device. The BMC will generate SEL events by monitoring registers on the HSBP microcontroller for drive presence, fault, and RAID rebuild in progress.

I2C uses a 5pin connector; this is to add two additional address bits. This connector is keyed differently than the 5pin SGPIO connector. The 4x3.5" HSBP architecture is setup to support up to 3 HSBPs even though the 4x 3.5" HSBP is currently only indented to support up to two of them in the Intel® Server Chassis P4000S, P4000M and P4000L family. Two pins on the I2C header are used to indicate HSBP address. Below is a figure on how the addressing is recommended for up to three HSBPs.

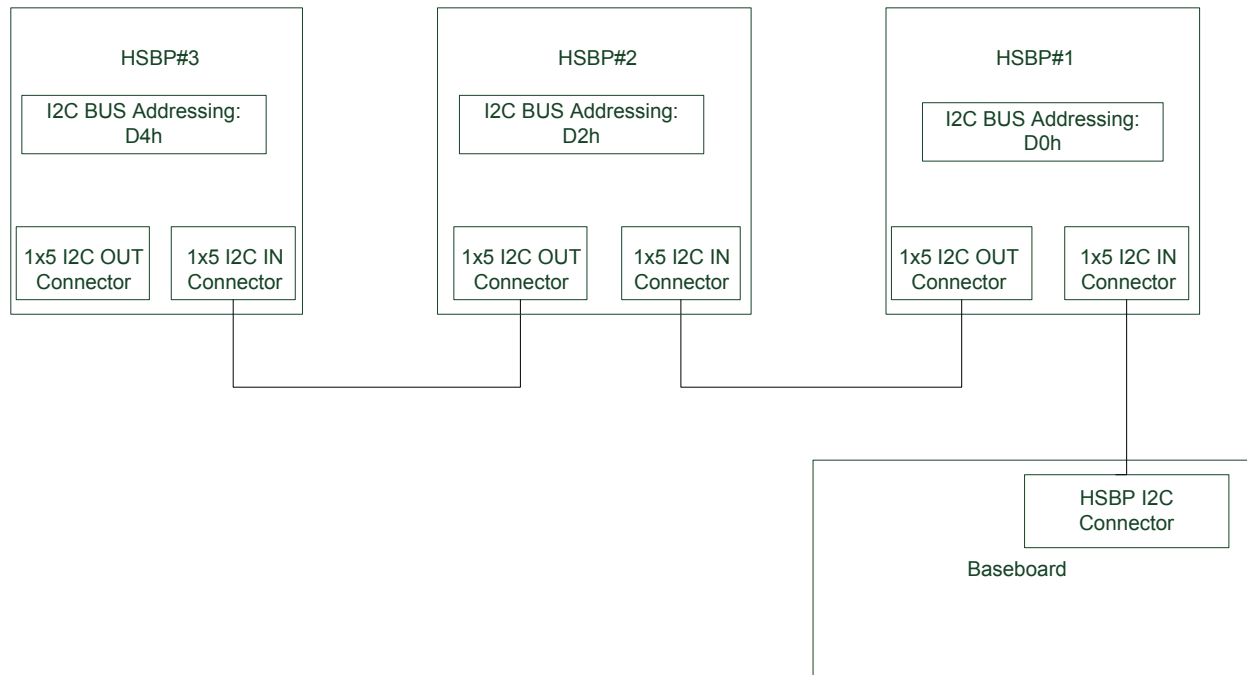

Figure 20. 4x 3.5" HSBP I2C Connectivity

## 5.2.4 HSBP LED Functionality

Below is a table for EPSP LED functionality for HSBP board.

**Table 30. Romley LED Functionality**

HDD	Green	Blink	HDD access or spin up/down (see note below)
	Amber	On	HDD fault
	Amber	Blink	RAID rebuild in progress (1Hz), identify (2Hz)
		Off	No access and no fault

The HSBP does not route HDD activity signal to the front panel so is not subject to the LED being continuously on when running SAS HDDs. Any HDD activity (really bus activity) driven from SATA/SAS host on baseboard or HBA card hosts that cable HDD activity to baseboard 2pin header would still result in the FP LED blinking. Below is a table showing HDD activity LED differences between with SATA and SAS HDDs.

**Table 31. HDD Activity LED Functionality**

Condition	Drive Type	Behavior
Power On with no drive activity	SAS	Ready LED stays On.
	SATA	Ready LED stays Off.
Power On with drive activity	SAS	Ready LED blinks Off when processing a command.
	SATA	Ready LED blinks On when processing a command.
Power On and drive spun down	SAS	Ready LED stays Off.
	SATA	Ready LED stays Off.
Power On and drive spun down	SAS	Ready LED blinks*.
	SATA	Ready LED stays Off.

HSBP does not need to route HDD fault LED function to front panel fan board. This function is already lumped with system fault LED already on the FP.

## 5.2.5 HDD Numbering Scheme

HDD Numbering starts with HDD0 from lower left side of chassis (facing front of system). Increment HDD number from bottom to top HDD column first then move to next HDD column to the right starting at bottom. See below for example of HDD numbering.

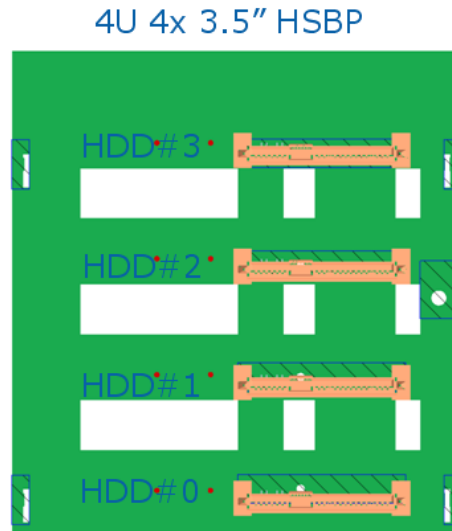

Figure 21. 4x 3.5" HSBP HDD Numbering Scheme

### 5.3 4x3.5" HSBP Connector List and Pinouts

Below is a list of the connectors needed for this board.

Table 32. 4x3.5" HSBP Connector List

Function	Color	Qty
29Pin Hot Swap Docking Connector	Black	4
7Pin Input SAS/SATA Connector	Black	4
1x4Pin Power Connector	White	2
1x5Pin I2C Connector (In)	White	1
1x5Pin I2C Connector (Out)	Blue	1
1x5Pin SGPIO Connector	White	1

#### 5.3.1 Pinouts

Table 33. 4x3.5" HSBP SGPIO Connector Pinouts

	Description
-	1x5pin SATA SGPIO
Pin	Signal Description
1	SGPIO_CLOCK_0
2	SGPIO_LOAD_0
3	GND
4	SGPIO_DATAOUT_0
5	SGPIO_DATAIN_0

**Table 34. 4x3.5" HSBP I2C(In) Connector Pinouts**

	Description
-	1x5Pin I2C Connector (In)
Pin	Signal Description
1	SMB_3V3SB_DAT
2	GND
3	SMB_3V3SB_CLK
4	SMB_ADD0
5	SMB_ADD1

**Table 35. 4x3.5" HSBP I2C (Out) Connector List**

	Description
-	1x5Pin I2C Connector (Out)
Pin	Signal Description
1	SMB_3V3SB_DAT
2	GND
3	SMB_3V3SB_CLK
4	SMB_ADD0
5	SMB_ADD1

**Table 36. 4x3.5" HSBP Power Connector Pinouts**

	Description
	1x4Pin Power Connector
Pin	Signal Description
1	P12V
2	GND
3	GND
4	P5V

---

**Note:** See SAS/SATA specs for pinout of 29pin and 7pin connectors.

---

## 5.4 4x3.5" HSBP Supported Servers & Baseboards

The following table shows this 4x 3.5" HSBP supported chassis and baseboards.

**Table 37. 4 x 3.5" HSBP Supported Chassis & Associated Baseboards**

Supported Chassis	Associated Baseboard
Intel® Server Chassis P4000S family	Intel® Server Board S1200BT Series
Intel® Server Chassis P4000M family	Intel® Server Board S2600CP

## 5.5 4x3.5" HSBP Cabling Requirements

The 4x 3.5" HSBP is intended to be use with up to 6Gb SATA/SAS HDDs. The 4x 3.5" HSBP requires the following cables:

1. Ganged 4x SATA/SAS data cable.
2. I2C cable - 5pin on HSBP side to 3pin on baseboard side
3. SGPIO cable - 5pin on HSBP side to 5pin on host controller side.

## 6. System Interconnection

### 6.1 Chassis Internal Cables

#### 6.1.1 Front Panel Cable

A 24-conductor ribbon cable with 24-pin IDC connectors links the front panel to the SSI EEB Revision 3.61-compliant server board.

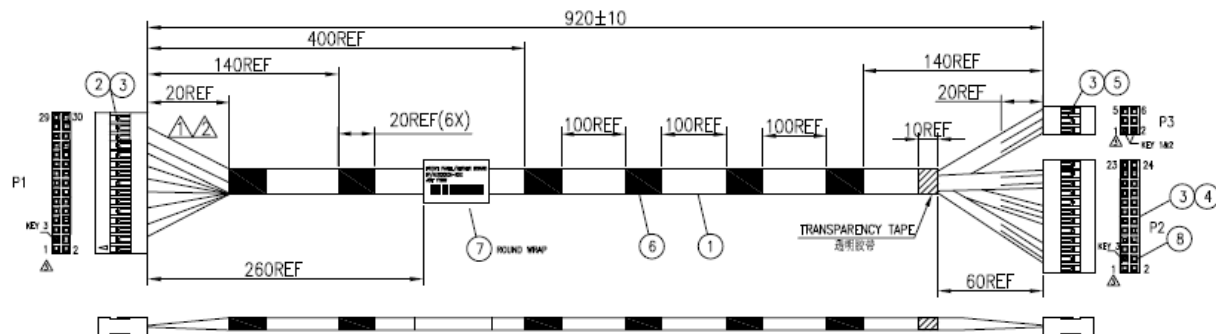

Figure 22. Chassis Front Panel Cable

#### 6.1.2 Intrusion Switch cable

The intrusion switch cable acts as a switch installed on the chassis for chassis intrusion detection, allowing server management software to detect unauthorized access to the system side cover. The cable is connected to the front panel through a 2-pin chassis intrusion header on the front panel board.

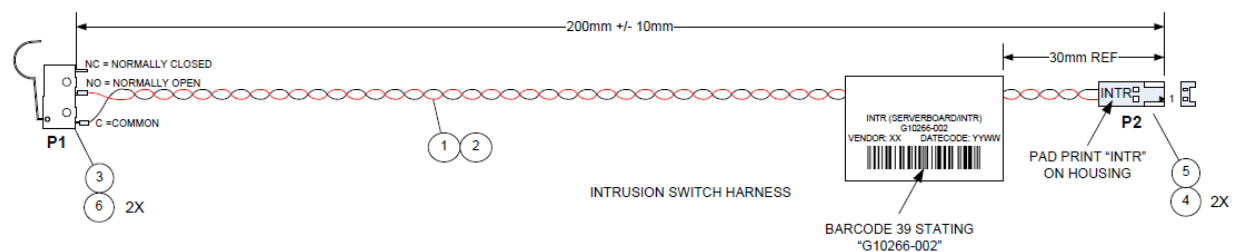

Figure 23. Intrusion Switch Cable

#### 6.1.3 USB Cable

A 10-conductor USB cable with 10-pin connectors at one end and two 4-pin external USB connectors at the other end is used for connecting the front panel-mounted USB connector to the server board.

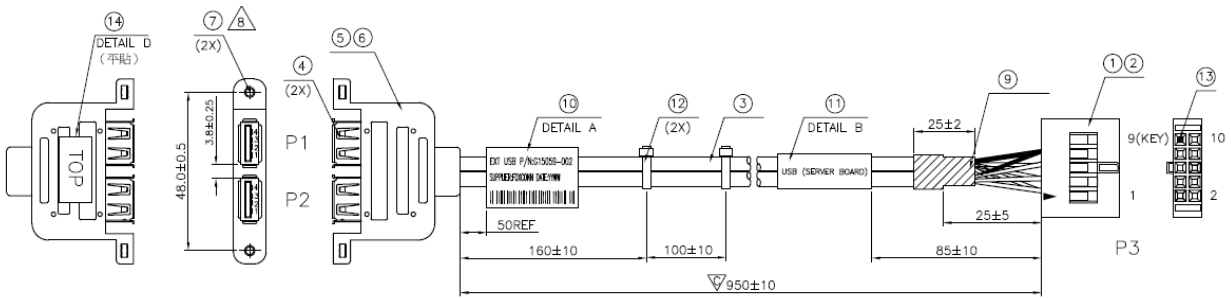

Figure 24. USB Cable Drawing

### 6.1.4 SATA Power Adapter Cable

The SATA Power Adapter Cable has a 4-pin LP4 connector at one end, two 15-pins SATA power connector at the other end. The cable is used for connecting the SATA Hard Drive to a standard 4-pin LP4 power connector.

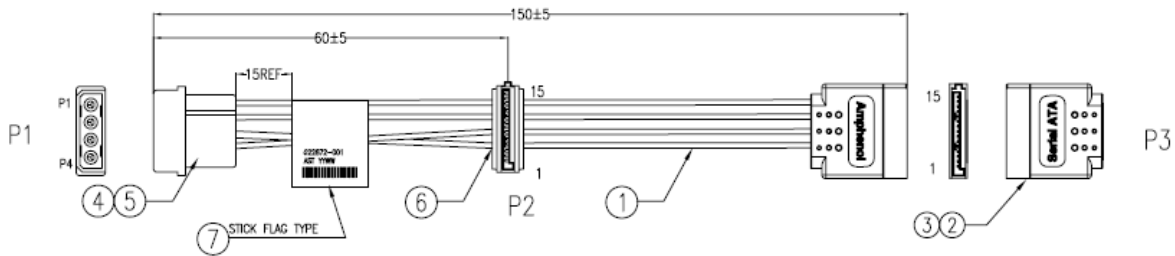

Figure 25. SATA Power Adapter Cable

### 6.1.5 SATA cable for HDDs/ODD

The SATA cables with two 7-pin SATA connectors are used for connecting the SATA HDDs/ODD to the server board.



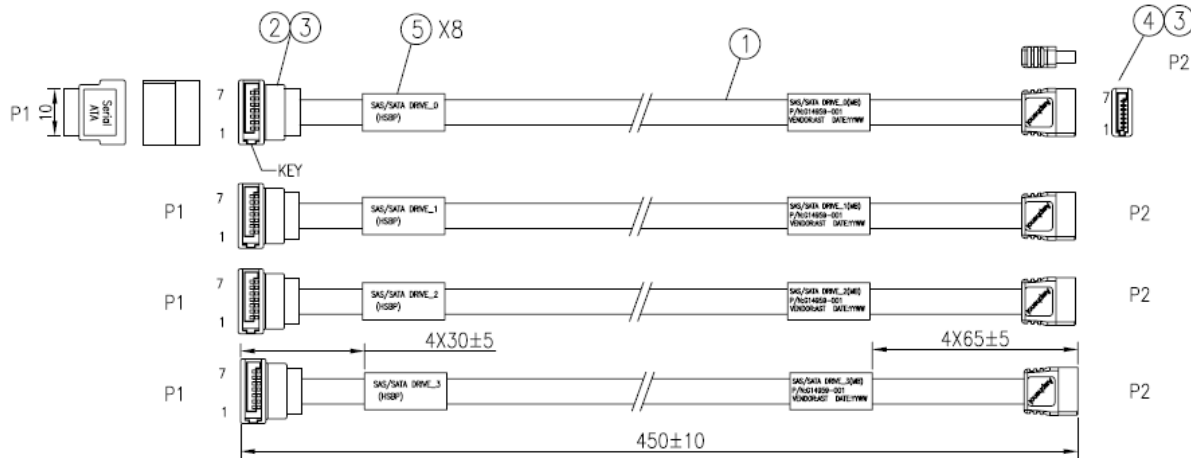

Figure 26. SATA cable for HDDs (450mm)

### 6.1.6 I2C Cable

The I2C cable is used for enclosure management communication between I/O controller (RAID) and backplane.

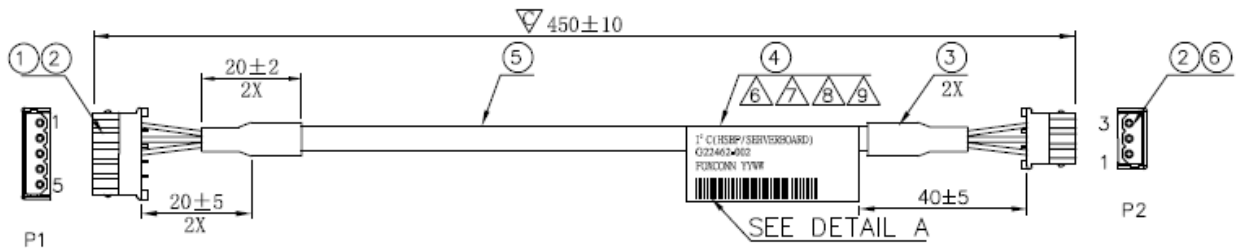

Figure 27. I2C Cable

### 6.1.7 SGPIO Cable

The SGPIO cable acts as an enclosure management interface between ESB2 and the backplane and is used by SW RAID to provide basic array device status indication via visual LEDs.

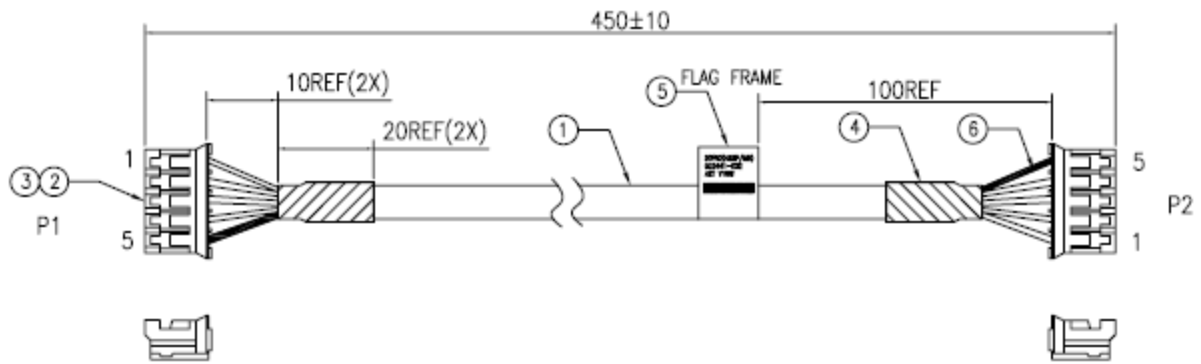

Figure 28. SGPIO Cable

## 7. System-Compatible Intel® Server Boards

---

The Intel® Server Chassis P4000S family supports the following Intel® server boards:

**Table 38. System-Compatible Intel® Server Boards**

Configuration	Intel® Server Chassis P4304XXSFCN	Intel® Server Chassis P4304XXSHCN
Intel® Server Board Support	<ul style="list-style-type: none"> <li>• S1200BTL</li> <li>• S1200BTS</li> </ul>	<ul style="list-style-type: none"> <li>• S1200BTL</li> </ul>
Supported Back Plane	4x3.5" hot-swap back plane	
Power Delivery	One fixed 365-w non-redundant PSU.	
Cooling	non redundant cooling, One 92x38mm rear system fan.	
Drive Bays	Four fixed HDD carrier trays. Supports up to four 3.5" fixed hard drives.	4x3.5" hot-swap hard drive cage. Support up to four 3.5" hot-swap hard drives

## 8. Reliability, Serviceability, and Availability

### 8.1 Mean Time between Failure

The following is the calculated Mean Time Between Failures (MTBF) at maximum configuration at 40°C (ambient air). These values are derived using a historical failure rate and multiplied by factors for application, electrical and/or thermal stress and for device maturity. MTBF estimates should be viewed as “reference numbers” only.

- Telcordia SR\_332 Issue II: Reliability Prediction Procedure
- Method 1: Parts Count Prediction
- Case III: Generic Value + Quality + Stress + Temperature
- Confidence Level: 90%
- Quality Level: II
- Temperature: Customer Specified (default 40 °C )
- Duty Cycle: Continuous, 100%
- Operating Environment: Ground Benign, Fixed, Controlled

**Table 39. Calculated Mean Time Between Failure**

Subassembly (Server in 40°C ambient air)	Intel® Server Chassis P4304XXSFCN		Intel® Server Chassis P4304XXSHCN	
	MTBF	FIT	MTBF	FIT
	(Hours)	(Failures/10 <sup>9</sup> hrs)	(Hours)	(Failures/10 <sup>9</sup> hrs)
S1200BTL Baseboard	172,199	5,807	172,199	5,807
Power Supply (365 W Non Redundant)	619,607	1,614	619,607	1,614
Cooling fans (Non- redundant)	206,885	4,834	206,885	4,834
Backplane board			935,180	1,069
Front Panel board	8,272,282	121	8,272,282	121
Totals with motherboard=	80800	12,376	74300	13,445
Totals with motherboard =	152200	6,568	130900	7,638

### 8.2 Serviceability

The system is designed for service by qualified technical personnel only.

The desired Mean Time to Repair (MTTR) of the system is 30 minutes including the diagnosis of the system problem. To meet this goal, the system enclosure and hardware were designed to minimize the mean time to repair.

The following are the maximum times a trained field service technician should take to perform the listed system maintenance procedures after diagnosis of the system.

**Table 40. Maximum Maintenance Procedure Times**

Activity	Time Estimate
Remove cover	< 1 minute
Remove and replace fixed hard disk drive	<3 minutes
Remove and replace hot-swap hard disk drive	1 minute
Remove and replace 5.25-inch peripheral device	< 2 minutes
Remove and replace fixed power supply module	<3 minutes
Remove and replace fixed fan	1 minute
Remove and replace expansion board (PCI Adaptor Card)	<2 minutes
Remove and replace backplane board	<2 minutes
Remove and replace front panel board	<3 minutes
Remove and replace server board (with no expansion boards)	<10 minutes
Overall Mean Time To Repair (MTTR)	<30 minutes

## 9. Environmental Limits

---

### 9.1 System Office Environment

**Table 41. System Office Environment Summary**

Parameter	Limits
Operating temperature	+10°C to +35°C with the maximum rate of change not to exceed 10°C per hour.
Non-operating temperature	-40°C to +70°C
Non-operating humidity	50% to 90%, non-condensing with a maximum wet bulb of 28° C (at temperatures from 25° C to 35° C)
Acoustic noise	7.0 BA LWA in a typical office ambient temperature (18-25°C)
Shock Operating	Half sine, 2 g, 11 milliseconds
Shock Unpackaged	Trapezoidal, 25 g, velocity change 136 inches/second (□40 lbs to < 80 lbs)
Shock Packaged	Operational after a free fall of 9 – 36-inches depending on the weight
Vibration unpackaged	5 Hz to 500 Hz 2.20 g RMS random
Vibration packaged	5 Hz to 500 Hz 1.09 g RMS random
Packaged shock	Operational after a free fall of 9 – 36-inches depending on the weight
ESD	Air discharge: 0 to 15.0kV; Contact Discharge: 0 to 8.0kV

### 9.2 System Environmental Testing

The system will be tested per the Environmental Standards Handbook, Intel Doc 25-GS0009. These tests shall include:

- Acoustic Sound Power
- Temperature operating and non-operating
- Humidity non-operating
- Shock Operating, Shock Packaged and Shock unpackaged
- Vibration Packaged and Vibration Unpackaged
- AC, DC, and I/O Surge
- AC voltage, frequency, and source interrupt
- Conducted Immunity
- DC Voltage and Source Interrupt
- Electrical Fast Transient (EFT)
- Electrostatic discharge (ESD)
- Flicker and Voltage Fluctuation
- Power Frequency Magnetic Fields
- Power Line Harmonics

- Radiated Emissions
- Radiated Immunity
- Telecom Power Line Conducted Emissions
- Voltage Dip and Dropout
- Reliability Test

## 10. Product Regulatory Compliance

---

Please refer to the Server Products Regulatory and Safety document for the product regulatory compliance reference. The document can be downloaded from <http://www.intel.com/support/motherboards/server/>.



## ***Appendix A: Integration and Usage Tips***

This appendix provides a list of useful information that is unique to the Intel® Server Chassis P4000S family and should be kept in mind while integrating and configuring your server.

System fans are not hot swappable.

The Intel® Local Control Panel can only be used with systems configured with an Intel® Management Module.

Make sure the latest system software is loaded on the server. This includes system BIOS, FRU/SDR, BMC firmware, and hot-swap controller firmware. The latest system software can be downloaded from <http://www.intel.com/support/motherboards/server/>.

## Glossary

Word/Acronym	Definition
ACA	Australian Communication Authority
ANSI	American National Standards Institute
ATA	Advanced Technology Attachment
ATX	Advanced Technology Extended
Auto-Ranging	Power supply that automatically senses and adjust itself to the proper input voltage range (110 VAC or 220 VAC). No manual switches or manual adjustments are needed.
BMC	Baseboard Management Controller
CFM	Cubic Feet per Minute (airflow)
CMOS	Complementary Metal Oxide Silicon
Dropout	A condition that allows the line voltage input to the power supply to drop to below the minimum operating voltage.
EEB	Entry-level Electronics Bay
EM	Expander Management
EMC	Electromagnetic compatibility,
EMI	Electromagnetic Interference
EMP	Emergency Management Port
ESD	Electrostatic Discharge
FIT	Failures In Time
FP	Front Panel
FRB	Fault Resilient Booting
FRU	Field Replaceable Unit
GPIO	General Purpose Input and Output
HSBP	Hot-swap Backplane
I/O	Input/Output
I2C	Inter-Integrated Circuit
IPMB	Intelligent Platform Management Bus
IPMI	Intelligent Platform Management Interface
Latch Off	A power supply, after detecting a fault condition, shuts itself off. Even if the fault condition disappears, the supply does not restart unless manual or electronic intervention occurs. Manual intervention commonly includes briefly removing and then reconnecting the supply, or using a switch. Electronic intervention can be completed by electronic signals in the Server System.
LCD	Liquid Crystal Display
LCP	Local Control Panel
LPC	Low-Pin Count
LQFP	Lower Profile Quad Flat Pack
Monotonically	A waveform changes from one level to another in a steady fashion, without intermediate retrenchment or oscillation.
MTBF	Mean Time Between Failure
MTTR	Mean Time to Repair
Noise	The periodic or random signals over frequency band of 10 Hz to 20 MHz.

Word/Acronym	Definition
OCP	Over Current Protection
OTP	Over Temperature Protection
Over-current	A condition in which a supply attempts to provide more output current than the amount for which it is rated. This commonly occurs if there is a 'short circuit' condition in the load attached to the supply.
OVP	Over Voltage Protection
PDB	Power Distribution Board
PFC	Power Factor Correction
PMBus	Power Management Bus
PSU	Power Supply Unit
PWM	Pulse Width Modulate
ppm	Parts per million
PWOK	A typical logic level output signal provided by the supply that signals the Server System that all DC output voltages are within their specified range
RI	Ring Indicate
Ripple	The periodic or random signals over frequency band of 10 Hz to 20 MHz.
Rise Time	The time it takes any output voltage to rise from 10% to 95% of its nominal voltage.
Sag	The condition where the AC line voltage drops below the nominal voltage conditions
SAS	Serial Attached SCSI
SATA	Serial ATA
SCA	Single Connector Attachment
SCSI	Small Computer System Interface
SDK	Software Development Kit
SDR	Sensor Data Record
SE	Single-Ended
SES	SCSI Enclosure Service
SGPIO	Serial General Purpose Input/Output
SMBUS	System Management Bus
SSI	Server System Infrastructure
Surge	AC line voltage rises above nominal voltage
TACH	Tachometer
THD	Total Harmonic Distortion
UART	Universal Asynchronous Receiver Transmitter
USB	Universal Serial Bus
VCCI	Voluntary Control Council for Interference
VSB or Stand By	An output voltage that is present whenever AC power is applied to the AC inputs of the supply.