

General Installation Process

The installation instructions in this section are for general components of Intel® Server Chassis P400M family, but the illustrations are based on the Intel® Server Chassis P4308XXMFEN.

Minimum Hardware Requirements

To avoid integration difficulties and possible damage to your system, make sure you have components from each category below.

- Processor
- Heat Sink
- Memory
- Hard Disk Drives
- Power
- Air Duct

1 Remove the Side Cover

- Remove the screws.
- Slide the side cover back and lift the cover outward to remove it.

Note:
A non-skid surface or a stop behind the chassis may be needed to prevent the chassis from sliding on your work surface.

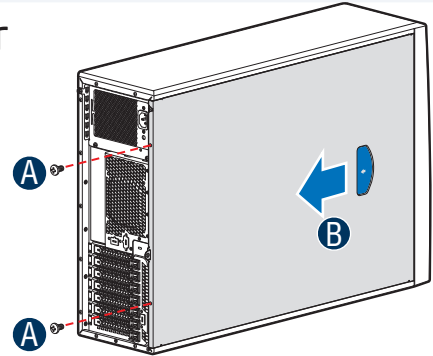

2 Remove the Bezel Assembly

CAUTION: Do not rotate the bezel assembly more than 40° or you will damage the bezel hooks at the right side of the bezel assembly.

- Release the two plastic tabs on the left side of the bezel assembly to disengage the tabs, and rotate the bezel assembly no more than 40 degrees outward.
- At a 40-degree angle, push the bezel assembly away from the chassis.

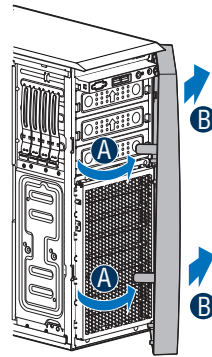

3 Install Server Board

- See your *Intel® Server Board Quick Start User's Guide* for server board installation instructions and installation of the back panel I/O shield.
- Use the mounting screws, bumpers and standoffs (if necessary) that come with your chassis to secure the server board to the chassis. Return to this document when finished.

4 Install Hard Drive

Fixed Hard Drive Carrier (For chassis with fixed hard drive bay only)

A. Remove the EMI shield

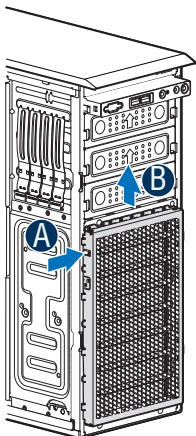

- Press the clip.
- Lift the EMI shield and move EMI shield outward from the chassis.

B. Install the Hard Disk Drive

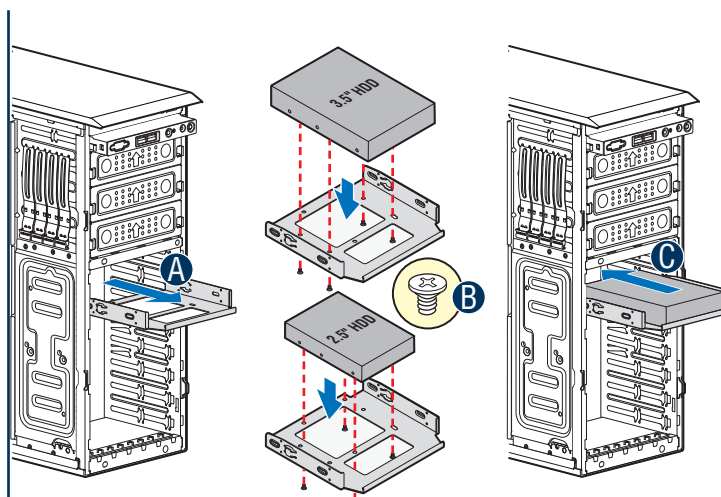

- Pull out the HDD carrier tray.
- Secure the 3.5" or 2.5" HDD on the HDD carrier tray with screws.
- Insert the HDD carrier tray into chassis.

C. Install the EMI shield

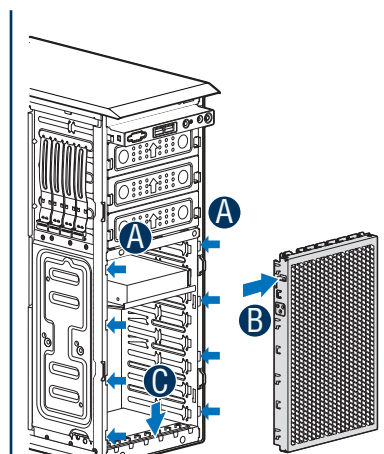

- Fit the edges of the EMI Shield against the sides of the chassis.
- Press the clip.
- Slide the EMI Shield downwards until the latches on the EMI Shield are engaged with the chassis.

General Installation Process

Install Hard Drive ... Continued

2.5" Hot-Swap Hard Drive Carrier (For chassis with 2.5" hot-swap hard drive bay only)

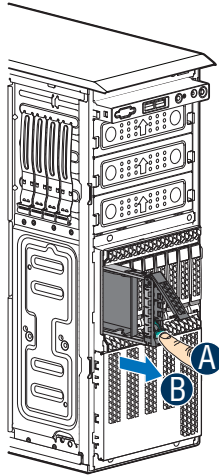

- A** Remove the drive carrier by pressing the **green** button and opening the lever.
- B** Slide the carrier out.

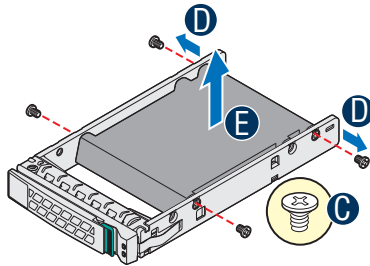

- C** Remove the four screws securing the plastic retention device to the 2.5" HDD carrier.
- D** Disengage the plastic retention device from the HDD carrier slides by pulling the slides.
- E** Remove the plastic retention device from the 2.5" HDD carrier.

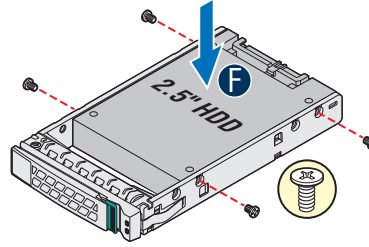

- F** Install the hard disk drive using the four screws as shown. Make sure the connector end of the drive matches the backplane connector.



CAUTION: If you don't install all drives, empty drive bays must be occupied by carriers with plastic drive blank provided to maintain proper system cooling.

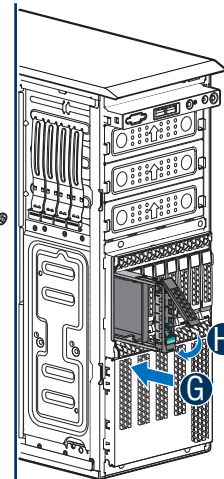

- G** With the lever open, insert the hard disk drive assembly into the cage opening and push until the locking lever engaged.
- H** Push in the lever to lock it into place.

Install Hard Drive ... Continued

3.5" Hot-Swap Hard Drive Carrier (For chassis with 3.5" hot-swap hard drive bay only)

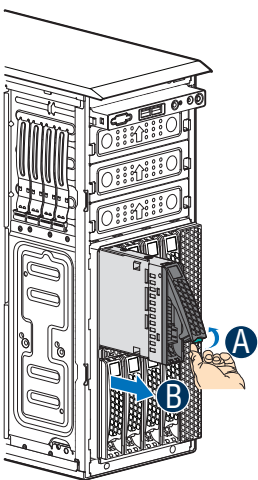

- A** Remove the drive carrier by pressing the **green** button and opening the lever.
- B** Slide the carrier out.

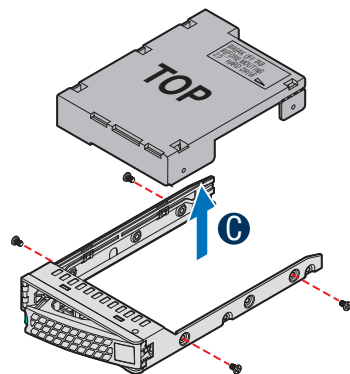

- C** Remove the four screws securing the HDD interface bracket and remove the HDD interface bracket.

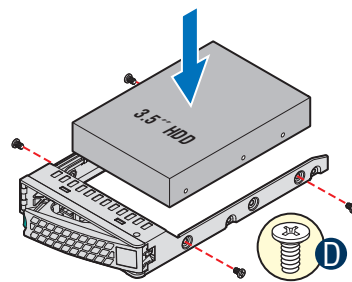

- D** Install the hard disk drive using the same four screws as shown. Make sure the connector end of the drive matches the backplane connector.



CAUTION: If you don't install all drives, empty drive bays must be occupied by carriers with plastic drive blank provided to maintain proper system cooling.

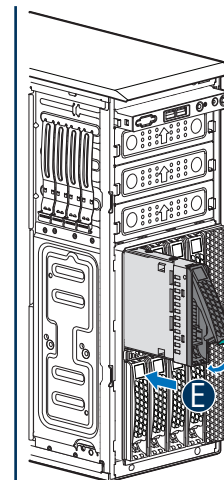

- E** With the lever open, insert the hard disk drive assembly into the cage opening and push until the locking lever engaged.
- F** Push in the lever to lock it into place.

General Installation Process

Install Hard Drive ... Continued

Install 2.5" Hard Drive into 3.5" Hot-swap Hard Drive Carrier as option:

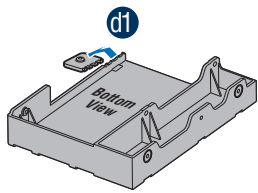

d1 Break off the tab on the HDD interface bracket.

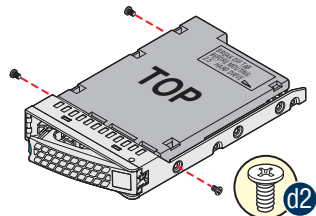

d2 Install the HDD interface bracket from top. Secure the bracket with three screws as shown.

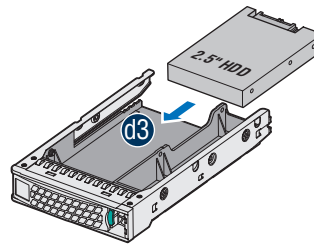

d3 Slide the 2.5" HDD into the bracket to align the screw holes with the right and left rail.

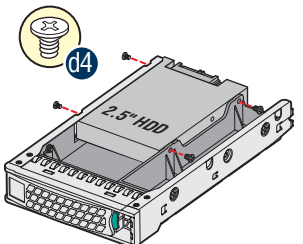

d4 Secure the hard disk drive using the four screws for 2.5" HDD.

5

Install Tool-less CD-ROM or DVD-ROM Drive

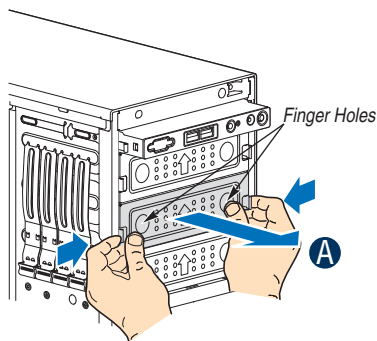

A Press the release latch and use the finger holes to Pull out the EMI shield.

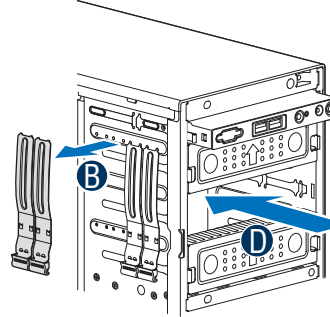

B Get the slides from the chassis side.

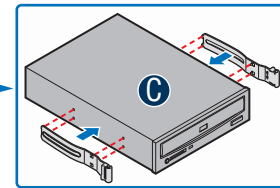

C Attach slides to the DVD or CD-ROM drive by pressing the slides firmly into the side dimples on the DVD or CD-ROM drive.

D Insert the drive/slide assembly into the device bay until the slides lock into place.

6

Install and Route Data and Power Cables

Description
A. CPU1/CPU2 Power Cable
B. Server Board Main Power Cable
C. Power Cable to Hard Drive Bay
D. Power Cable to ODD
E. Front Panel Cable, USB Cable
F. ODD Data Cable
G. SATA cable and SGPIO** cable
H. PMBus* Cable
I. HSBP_I2C** Cable (5pin to 3pin, provide connection from hot-swap back plane to server board)
J. HSBP_I2C Cable (5pin to 5pin, only for the chassis with 2 hot-swap back plane cascade)

*only for the chassis with hot-swap power supply
 **only for the chassis with hot-swap drive bay

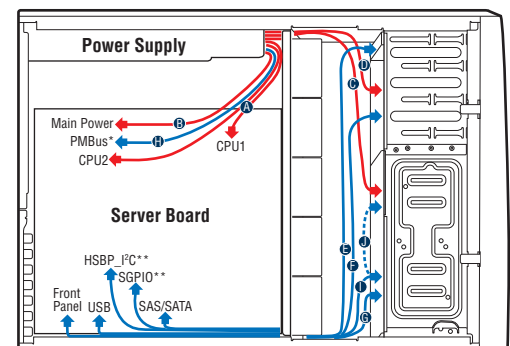
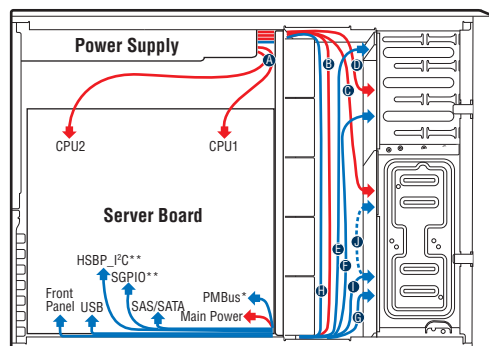

Note:

Front Panel, USB cable are pre-routed by the factory.

SATA adapter cables are needed in order to connect power cable to fixed SATA HDD connector.

See more backplane cable connection instruction in **Reference** in P14

RED indicates power cable routing **BLUE** indicates data cable routing

General Installation Process

7

Complete Server Board Cabling Connections

See your **Intel® Server Board Quick Start User's Guide** or **Service Guide** for server board and system cable connections.

Return to this document when finished .

8

Install PCI-e Card Assembly

- A** Remove the PCI-e slot shield by pushing the shield out from inside the chassis.
- B** Install the optional PCI-e card fixture with screws. The card fixture helps to hold heavy PCI-e cards (i.e GPGPU card). The card fixture is ordered separately.

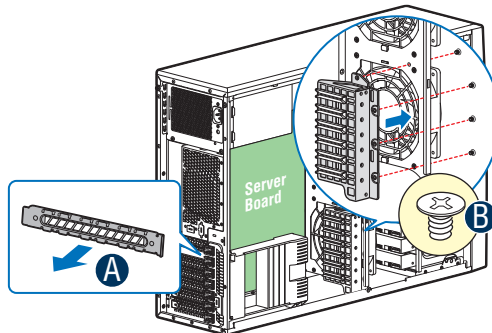

- C** Rotate the PCI-e retainer all the way to open.

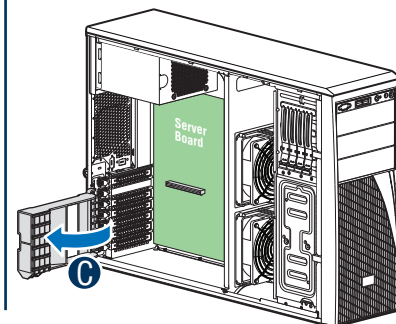

Install PCI-e Card Assembly ... Continued

- D** From inside of chassis, press open the back panel PCI-e add-in board retention device.

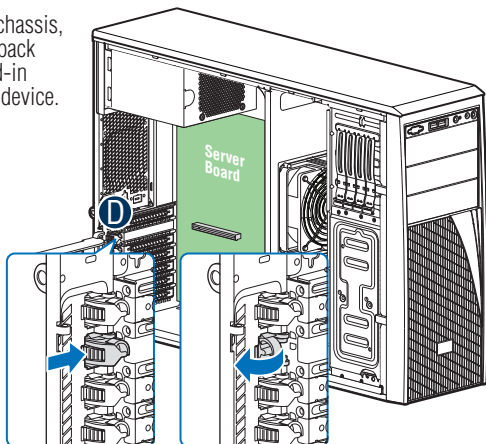

- E** While holding the PCI-e add-in board by its top edge or upper corners, firmly press the add-in board into the expansion slot.

Note: If the optional card fixture is installed, align the PCI-e card with card fixture slot while pushing down the card.

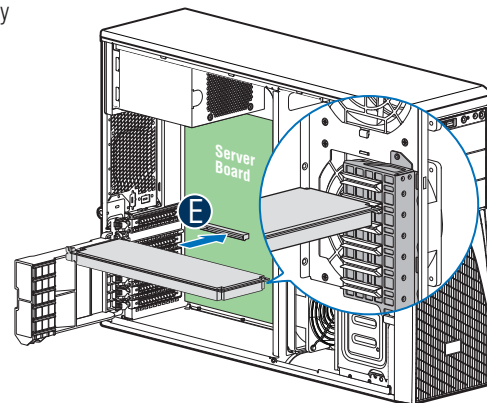

Install PCI-e Card Assembly ... Continued

- F** Close the PCI-e add-in board retention device.

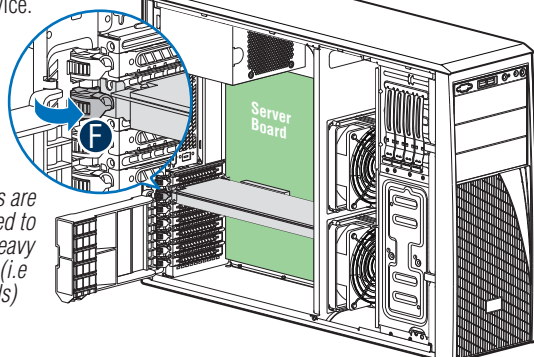

Note: Screws are recommended to secure the heavy PCI-e cards (i.e GPGPU cards) with chassis back panel.

- G** Rotate the PCI-e card retainer until the PCI-e card retainer is secured by the chassis.

Make sure the PCI-e card is secured into the slot under the PCI-e card retainer.

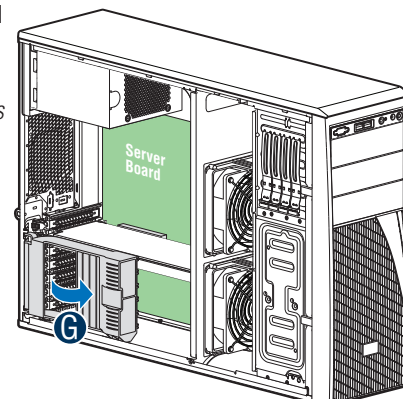

General Installation Process

9

Install Intel® Remote Management Module 4 NIC (optional)

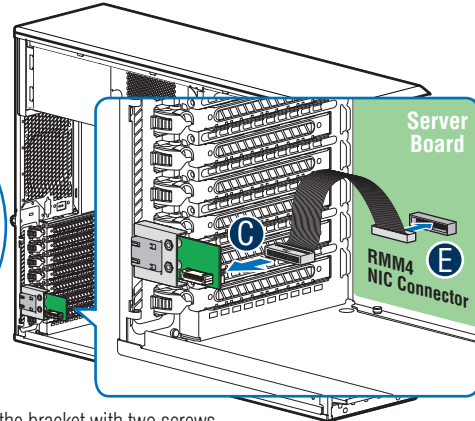
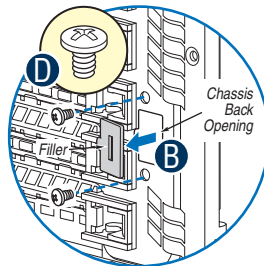
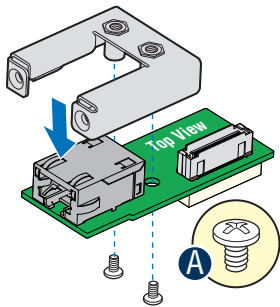

- A** Attach the metal fastening bracket to Intel® Dedicated Server Management NIC module and secure the bracket with two screws.
- B** Remove the alternate RMM4 knock out by pressing the knock out from inside the chassis.
- C** Connect the cable to the cable connector on the Intel® Dedicated Server Management NIC module.
- D** Mount the NIC module to the rear panel of the chassis and secure the bracket with two screws.
- E** Connect the cable to the RMM4 NIC connector on your server board.

Caution: Carefully remove the knock out with screwdriver, directly removing it with finger has potential risk.

Caution: Care should be used when attaching or removing this cable. Mishandling the cable could cause damage.

10

Install RMM4 EMI Cover (optional)

- A** Install the RMM4 EMI cover with thumb screws.

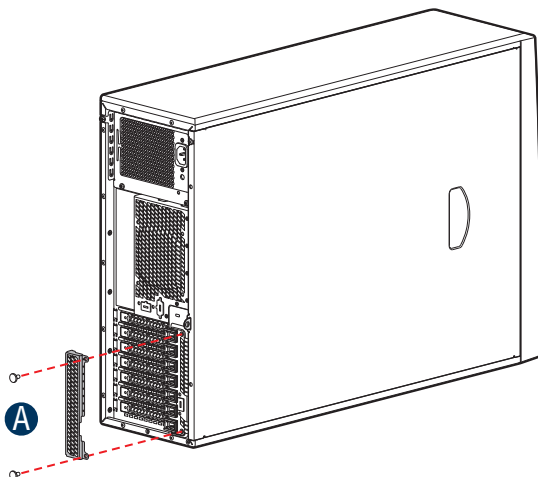

11

Install Alternate Serial Port (optional)

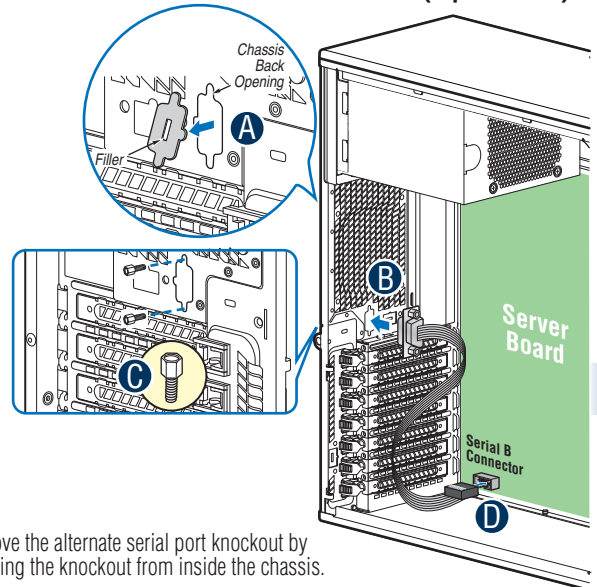

- A** Remove the alternate serial port knockout by pressing the knockout from inside the chassis.

Caution: Carefully remove the knock out with screwdriver, directly removing it with finger has potential risk.

- B** Mount the serial serial port on the rear panel of the chassis.
- C** secure the port with two screws.
- D** Connect the cable to the Serial B Connector on your server board.

Caution: Care should be used when attaching or removing this cable. Mishandling the cable could cause damage.

General Installation Process

12 Install Intel® RAID Smart Battery (optional)

- A** Align the tabs on the plastic battery holder with the mounting holes in the chassis and slide the plastic battery holder toward the front of the chassis until the tabs engage with the mounting holes.

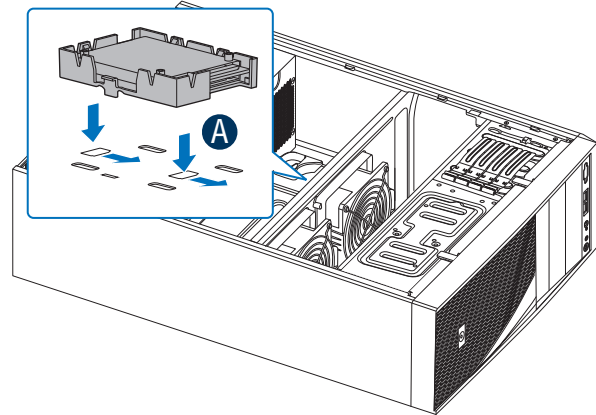

13 Install Second Power Supply Module (optional)

Note: Applies only to the chassis with hot-swap power supply configuration.

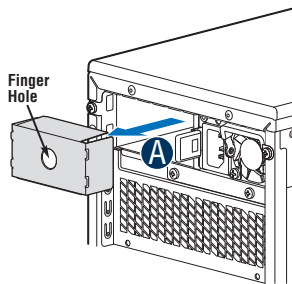

- A** Use the 'finger hole' to remove the filler panel.

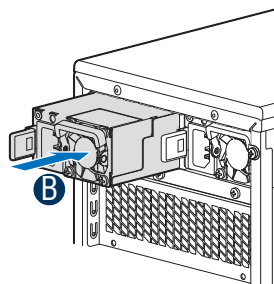

- B** Insert the power supply module into the power supply cage and push all the way until it clicks into place.

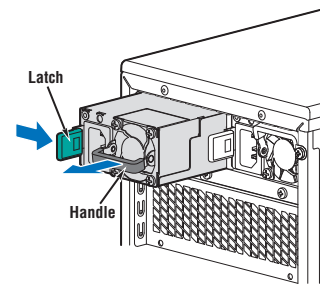

To remove a power supply module, push the green latch in the direction shown while pulling out of the system by the handle.

14 Rack Mount Configuration (optional)

- If you intend to configure your server as a pedestal system, disregard this step.
- If you intend to configure your server as a rack mount system, go to the instructions that came with your Rack Mount Kit to complete your server assembly.

15 Remove Filler Panels

Remove the bezel filler panels for each drive you have installed. Release plastic tabs located at back side of bezel and pull out filler panels from front.

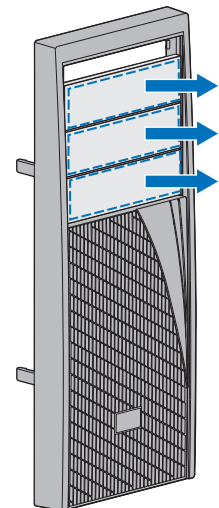

General Installation Process

16

Reinstall Front Bezel Assembly

- A** Engage three plastic bezel hooks into the raised metal slots at the chassis edge. *Keep the right edge of front bezel align tightly with the right edge of the Chassis.*
- B** Rotate the bezel assembly toward the chassis and latch the two plastic tabs on the left side of the bezel assembly to the chassis.

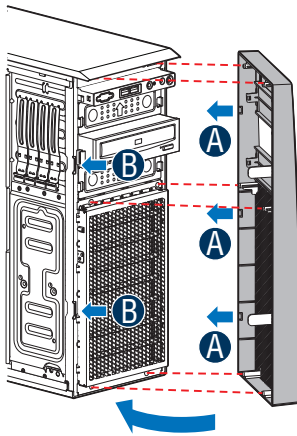

17

Install Feet (pedestal only)

Note: This step applies to your chassis if configured as a pedestal system. If you plan to configure your chassis as a rack-mount system, disregard this step.

- A** Insert rubber foot into chassis hole.
 - B** Secure foot by inserting pin through the rubber foot.
- Note:** Repeat above steps until all four feet are installed.

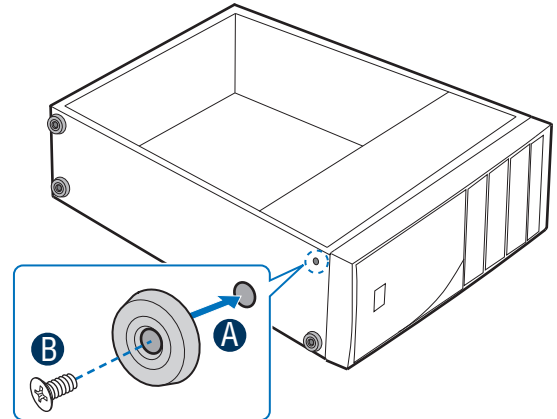

18

Install Air Duct

Note: Please order the air duct that compatible with your server board and chassis.

- A** Align the air duct and chassis rail.
- B** Install the air duct. Ensure that alignment holes and tabs match up.

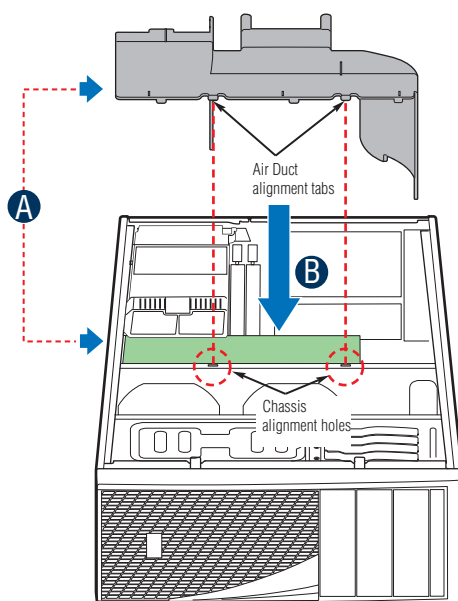

19

Install Side Cover

- A** Slide the chassis cover on the chassis.
- B** Secure the chassis cover with the screws.

CAUTION: This chassis must be operated with the SIDE COVERS installed to ensure proper cooling.

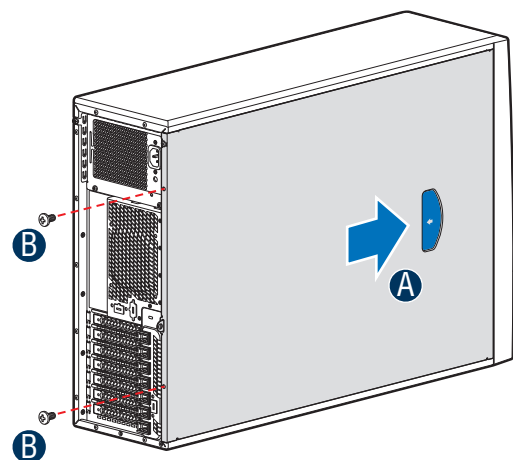

General Installation Process

20

Finishing Up

1. See your **Intel® Server Board Quick Start User's Guide** to connect your keyboard, mouse, video, and other I/O cables.
2. Connect the AC power cable last.

 **CAUTION:** power supply requires a 16-gauge power cord.

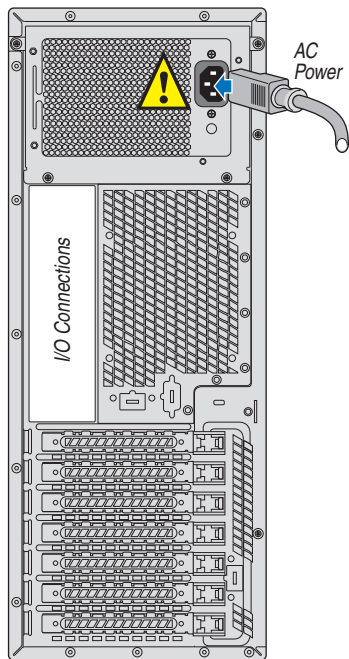

21

Install Software

- BIOS, Drivers, and Operating System Install

A. Confirm BIOS Version: Look on the Server/System Management screen in the BIOS Setup Utility to determine the installed BIOS version. Compare this to the versions at: <http://www.intel.com/support>. If new versions are available, update the BIOS on your server. See the User Guide on the Intel® Server Deployment and Management DVD for update instructions.

B. Configure your RAID Controller: Use the instructions provided with the RAID controller.

C. Install your Operating System: Use the instructions provided with the RAID controller and with the operating system.

D. Install Operating System Drivers: With the operating system running, insert the Intel® Server Deployment and Management DVD. If using a Microsoft* Windows* operating system, the Express Installer will autorun and allow you to select the appropriate drivers to install. On other operating systems, browse the DVD folders to locate and install the driver files.

HDD Cage Cable Connection

Note: Refer to the documentation that came with your server board and/or RAID controller card for instructions on connecting backplane cables to your server board or RAID controller card.

4 x 3.5" HDD Cage

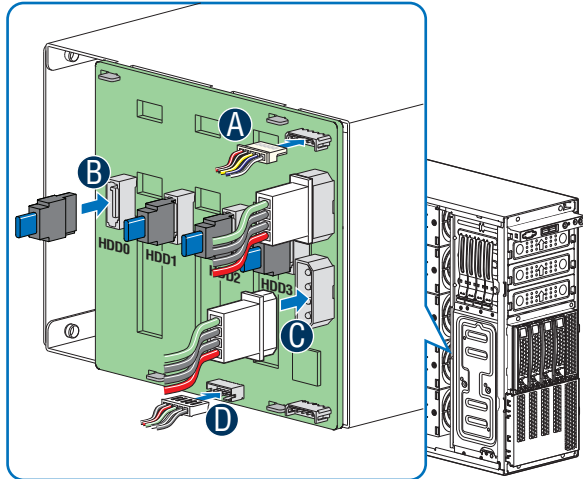

- A** Connect the I²C cable to I²C_IN connector on backplane.
- B** Connect the SATA data cables.
- C** Connect power cable.
- D** Connect SGPIO cable.

8 x 3.5" HDD Cage

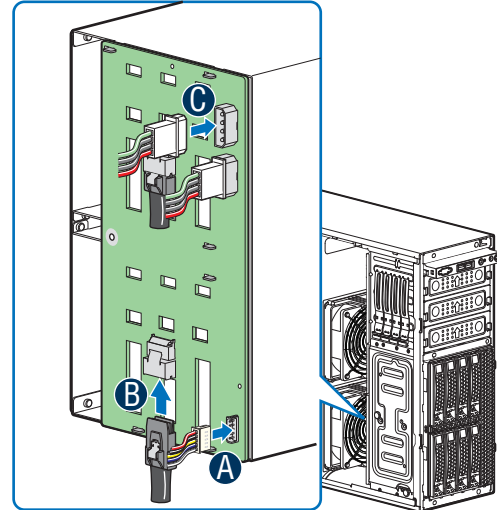

- A** Connect the I²C cable to I²C connector on backplane.
- B** Connect Mini SAS data cables.
- C** Connect two power cables.

8 x 2.5" HDD Cage

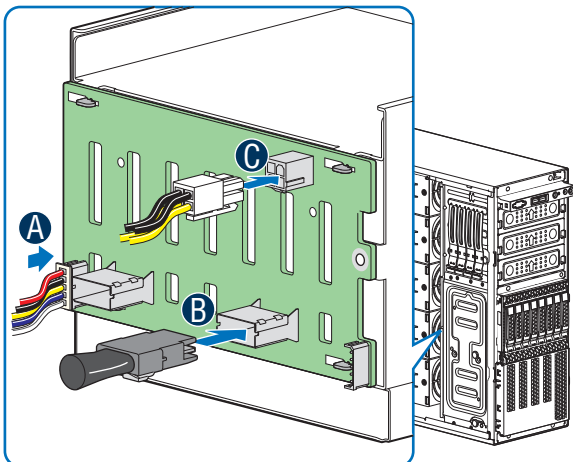

- A** Connect the I²C cable to I²C_IN connector on backplane.
- B** Connect Mini SAS data cables.
- C** Connect power cables* (1 x 4 to 2 x 2 Power adapter cable is needed).

16 x 2.5" HDD Cage

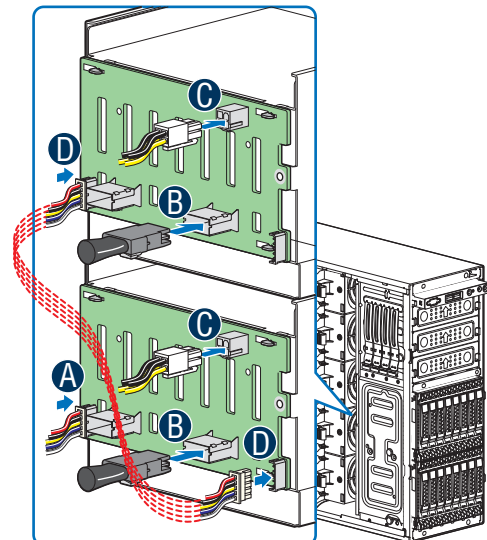

- A** Connect the I²C cable to I²C_IN connector on bottom 8x2.5" backplane.
- B** Connect Mini SAS data cables.
- C** Connect power cables* (1 x 4 to 2 x 2 Power adapter cable is needed).
- D** Connect I²C_OUT connector on bottom 8x2.5" backplane to I²C_IN connector on top 8x2.5" backplane for backplane cascade.

Reference

Front Panel Controls and Indicators

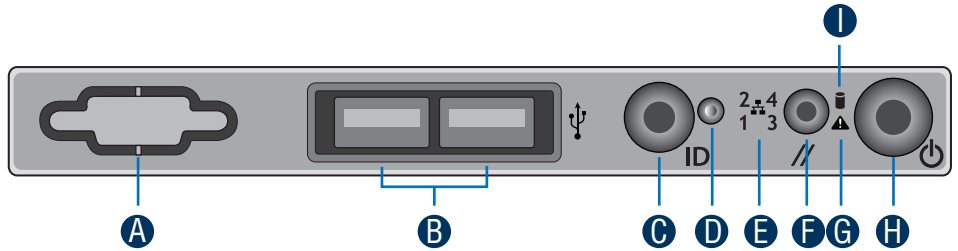

- A** Reservation(Optional VGA/Serial Port)
- B** USB Connectors
- C** ID Button with ID LED Integrated
- D** NMI Button
- E** NIC LED
- F** System Reset Button
- G** System Status LED
- H** System Power Button with Power LED
- I** HDD Activity LED

Hot Swap Hard Drive Bay Options and HDD Numbering

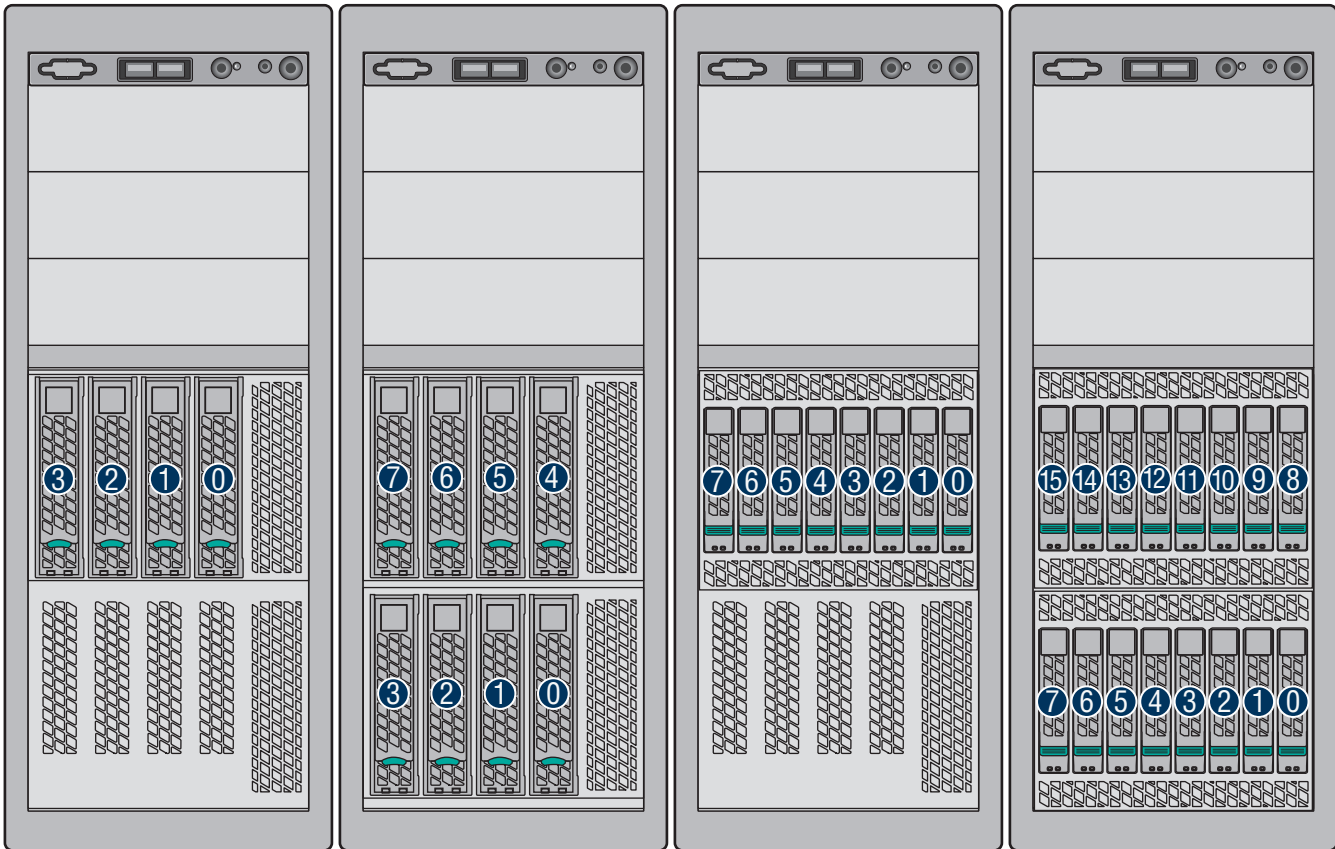

4 x 3.5"
Hot-Swap
Drive Cage

8 x 3.5"
Hot-Swap
Drive Cage

8 x 2.5"
Hot-Swap
Drive Cage

16 x 2.5"
Hot-Swap
Drive Cage

G30108-004

