

# Intel® Server Board S2600IP Intel® Workstation Board W2600CR Quick Start User's Guide

Thank you for buying the Intel® Server Board S2600IP or Intel® Workstation Board W2600CR. The following information will help you integrate your new server board into a server chassis.

For details on these chassis or to select a third party chassis, please visit <http://www.intel.com/go/serverbuilder> and <http://www.intel.com/support/motherboards/server>.

When installing the server board into a reference chassis, refer to the reference chassis instructions.

If you are not familiar with ESD (Electrostatic Discharge) procedures used during system integration, please see the *Intel® Server Board S2600IP or Intel® Workstation Board W2600CR Service Guide* at: <http://www.intel.com/support/motherboards/server>.

Please boot to the Intel® Server Deployment Toolkit CD first for BIOS and firmware configuration and updates.

Read all cautions and warnings first before starting your server system integration.

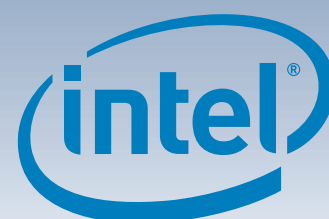
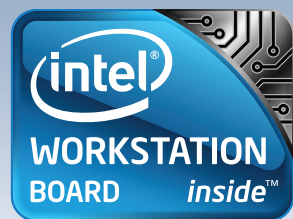
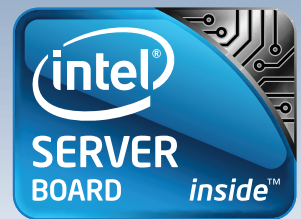

## Minimum Hardware Requirements

To avoid integration difficulties and possible board damage, your system must meet the following minimum requirements:

- Processor: Intel® Xeon® Processor E5-2600 series with compatible heat sink(s).
- Memory Type: Minimum of one 1 GB DDR3 800/1066/1333/1600 MHz ECC UDIMM/RDIMM/LRDIMM.
- Power: SSI EPS 5V compliant power supply, 750W minimum.

## Tools Required

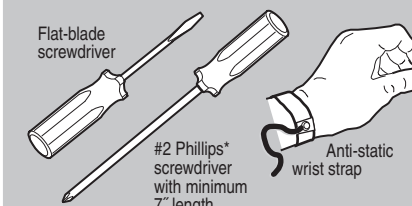

## Fastener Identification Guide

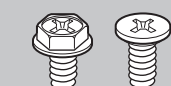

## 1 Preparing the Chassis

If using a non-Intel server chassis, refer to the documentation that came with your chassis for preparatory steps.

Observe normal ESD (ElectroStatic Discharge) procedures.

Place your Intel® Server Chassis and Intel® Server Board on a flat anti-static surface to perform the following integration procedures. Always touch the chassis frame first, before reaching inside to install the server board, make server board connections or install other components.

## 2 Installing the I/O Shield and Attach I/O Labels

Note: The I/O shield and label installation procedures shown below apply to the Intel® Server Chassis P4000 series.

### Attach the Labels to the I/O Shield (optional)

Note: Make sure you install the labels on the correct side of the I/O shield. Note the orientation of the cutouts in the drawing before attaching your labels.

- Remove the backing from one of the four I/O shield labels included with your server board.
- Press the label onto the I/O shield as shown.
- Repeat steps to install the rest of the I/O shield labels.

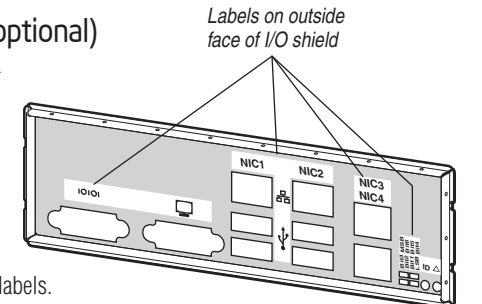

### Install the I/O shield

I/O Shield should be installed from **inside** of the chassis. The labels should be visible from the **outside** of the chassis.

- Insert one side edge of shield as shown.
- Push shield firmly into chassis opening until it clicks into place.

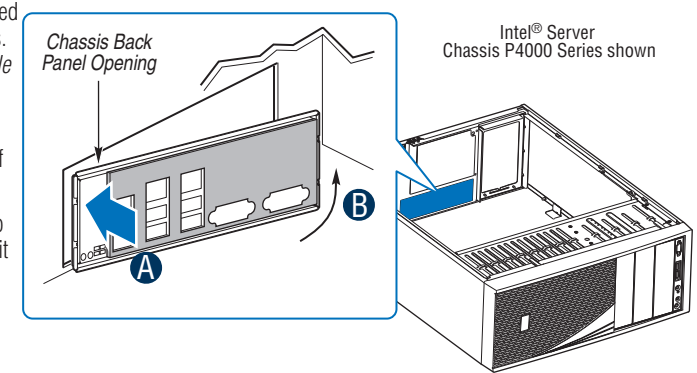

## 3 Install Server Board Bumpers

**IMPORTANT NOTE:** If you are using a non-Intel server chassis that includes bumpers, refer to the chassis documentation for bumper installation. If you are using a non-Intel server chassis that does not include bumpers, consult with the chassis vendor to determine if bumpers are required or not. If you are using an Intel® Server Chassis, use the chassis bumpers that came with the chassis.

### Prepare Server Board

- Rotate board to show underside and hold upright as shown.
- Locate the circles as shown.

**CAUTION:** To avoid damage to the server board, do not lay flat with the component side down.

### Attach the Bumpers

- Remove the backing from each bumper.
- Press bumpers onto the circles.

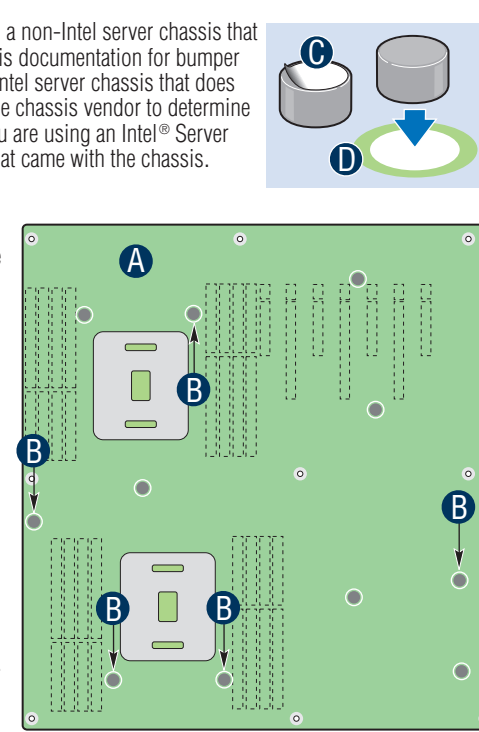

## Warning

Read all caution and safety statements in this document before performing any of the instructions. Also see the *Intel® Server Board and Server Chassis Safety Information* document at: <http://www.intel.com/support/motherboards/server/sb/cs-010770.htm> for complete safety information.

## Warning

Installation and service of this product should only be performed by qualified service personnel to avoid risk of injury from electrical shock or energy hazard.

## Caution

Observe normal ESD [Electrostatic Discharge] procedures during system integration to avoid possible damage to server board and/or other components.

## 4 Install the Server Board

**IMPORTANT NOTE:** If you are using a non-Intel server chassis, see your chassis documentation for preparatory steps prior to server board installation.

### A. Insert the Server Board

Place the board into the chassis, making sure that back panel I/O openings and chassis standoffs align correctly.

- When using the Intel® Server Chassis P4000 series, insert the front of the board first, then slide the board back so the I/O connectors fit through the I/O openings at the rear of the chassis.

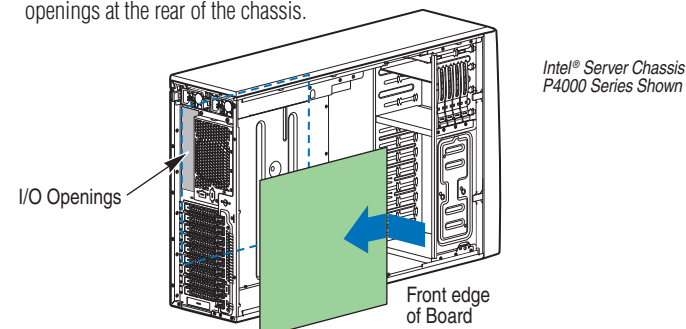

### B. Attach the Server Board

The directions below are for the Intel® Server Chassis P4000 series. For a non-Intel server chassis, use the fasteners that came with your chassis.

Use screws to attach the board to the chassis at the 9 locations indicated by the solid blue arrows in the figure.

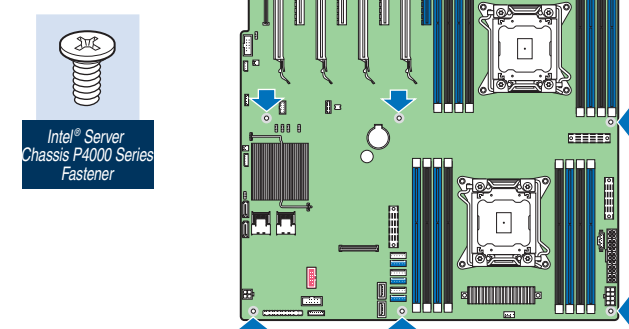

## 5 Install the Processor(s)

### A. Open the Socket Lever

- Push down the lever handle on the **OPEN 1st** side and away from the socket to release it.
- Repeat the steps to release the lever on the other side.

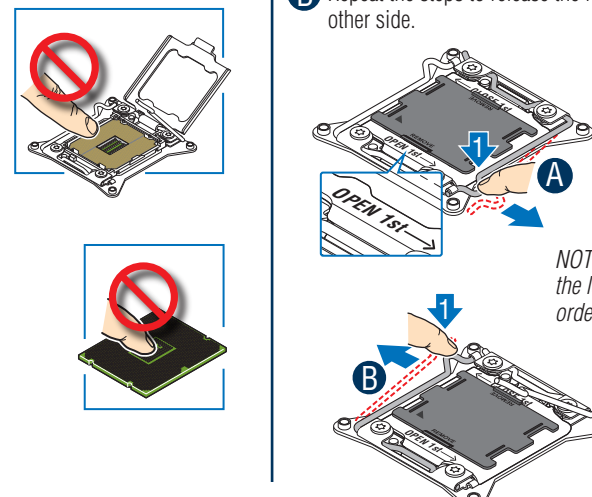

### B. Open the Load Plate

- Press the locking lever slightly to raise the load plate.
- Open the load plate all the way.

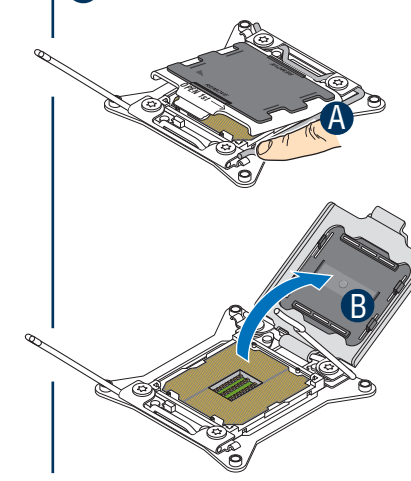

### C. Install the Processor

- CAUTION:** The underside of the processor has components that may damage the socket pins if installed improperly. Processor must align correctly with the socket opening before installation. **DO NOT DROP** processor into socket!
- Take the processor out of the box and remove the protective shipping cover.
- Orient the processor with the socket so that the processor cutouts match the four orientation posts on the socket.
- Note location of gold key at corner of processor.

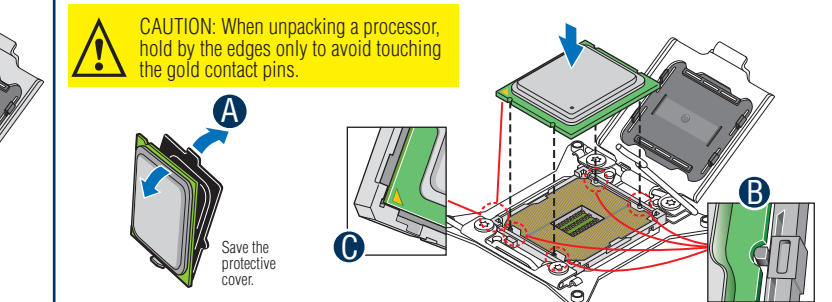

## Install the Processor(s) ... continued

### D. Remove the Cover

Press the cover to remove it.

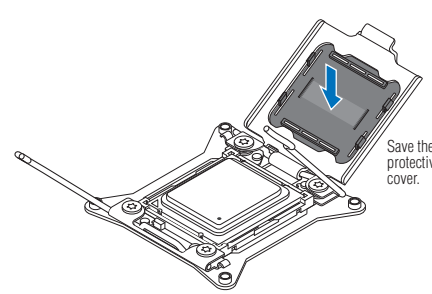

### E. Close the Load Plate

Carefully lower the load plate over the processor.

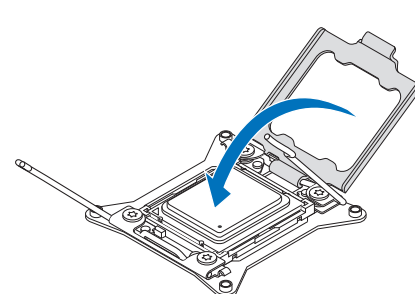

### F. Latch the Locking Lever

- Push down on the locking lever on the **CLOSE 1st** side.
- Slide the tip of the lever under the notch in the load plate. *Make sure the load plate tab engages under the socket lever when fully closed.*
- Repeat the steps to latch the locking lever on the other side.

**CAUTION:** Latch the locking levers in the order shown below.

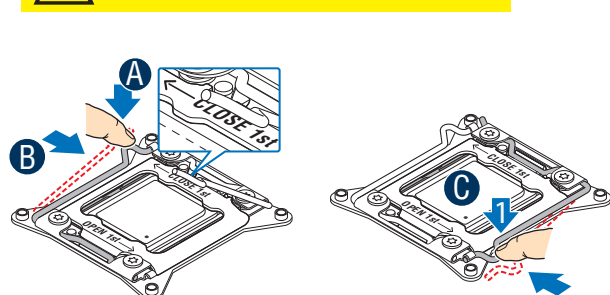

## 6 Install Heat Sink(s)

- Get heat sink from the shipping position.
- Remove the protective film on the TIM if present.
- Align heat sink fins to the front and back of the chassis for correct airflow. *Airflow goes from front-to-back of chassis.*
- Using a #2 Phillips\* screwdriver, finger-tighten each fastener diagonally, according to the numbers shown.
- Securely re-tighten each fastener again in the same order as performed in Step E.

**CAUTION:** The heat sink has thermal interface material (TIM) on the underside of it. Use caution so that you do not damage the thermal interface material. Use gloves to avoid sharp edges.

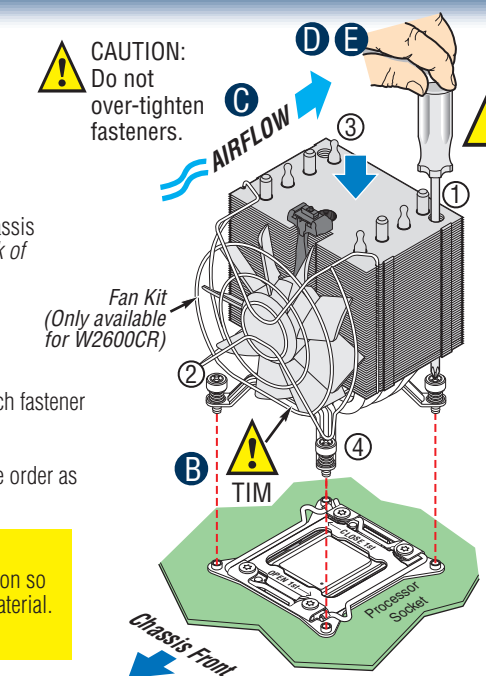

## 7 Install DIMM Memory Modules

### DDR3 DIMM Memory Identification:

- CAUTION:** Observe normal ESD (ElectroStatic Discharge) procedures to avoid possible damage to system components.
- This server board supports up to 16 DDR3 800/1066/1333/1600 ECC UDIMM/RDIMM/LRDIMM.

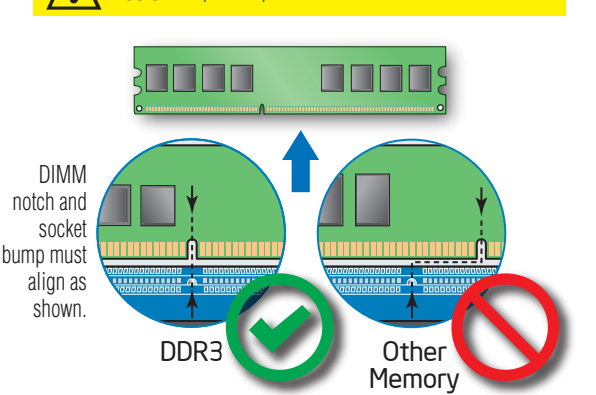

Intel is a registered trademark of Intel Corporation or its subsidiaries in the United States and other countries. \*Other names and brands may be claimed as the property of others. Copyright © 2012, Intel Corporation. All rights reserved.

G34152-004

