

Intel® Server System SR1530CL / SR1530HCL / SR1530HCLS and Intel® Server System SR1530CLR / SR1530HCLR / SR1530HCLSR User Guide

A Guide for Technically Qualified Assemblers of Intel® Identified Subassemblies/Products

Intel Order Number D68456-005

Disclaimer

Information in this document is provided in connection with Intel® products. No license, express or implied, by estoppel or otherwise, to any intellectual property rights is granted by this document. Except as provided in Intel's Terms and Conditions of Sale for such products, Intel assumes no liability whatsoever, and Intel disclaims any express or implied warranty, relating to sale and/or use of Intel products including liability or warranties relating to fitness for a particular purpose, merchantability, or infringement of any patent, copyright or other intellectual property right. Intel products are not designed, intended or authorized for use in any medical, life saving, or life sustaining applications or for any other application in which the failure of the Intel product could create a situation where personal injury or death may occur. Intel may make changes to specifications and product descriptions at any time, without notice.

Intel server boards contain a number of high-density VLSI and power delivery components that need adequate airflow for cooling. Intel's own chassis are designed and tested to meet the intended thermal requirements of these components when the fully integrated system is used together. It is the responsibility of the system integrator that chooses not to use Intel developed server building blocks to consult vendor datasheets and operating parameters to determine the amount of airflow required for their specific application and environmental conditions. Intel Corporation can not be held responsible if components fail or the server board does not operate correctly when used outside any of their published operating or non-operating limits.

Intel, Intel Pentium, and Intel Xeon are trademarks or registered trademarks of Intel Corporation or its subsidiaries in the United States and other countries.

* Other names and brands may be claimed as the property of others.

Copyright © 2010, Intel Corporation. All Rights Reserved

Safety Information

Important Safety Instructions

Read all caution and safety statements in this document before performing any of the instructions. See also Intel Server Boards and Server Chassis Safety Information on the *Intel® Server Deployment Toolkit 2.0 CD* and/or at <http://support.intel.com/support/motherboards/server/sb/cs-010770.htm>.

Wichtige Sicherheitshinweise

Lesen Sie zunächst sämtliche Warnung und Sicherheitshinweise in diesem Dokument, bevor Sie eine der Anweisungen ausführen. Beachten Sie hierzu auch die Sicherheitshinweise zu Intel-Serverplatinen und Servergehäusen auf der *Intel® Server Deployment Toolkit 2.0 CD* oder unter <http://support.intel.com/support/motherboards/server/sb/cs-010770.htm>.

Consignes de sécurité

Lisez attention toutes les consignes de sécurité et les mises en garde indiquées dans ce document avant de suivre toute instruction. Consultez Intel Server Boards and Server Chassis Safety Information sur le *Intel® Server Deployment Toolkit 2.0 CD* ou bien rendez-vous sur le site <http://support.intel.com/support/motherboards/server/sb/cs-010770.htm>.

Instrucciones de seguridad importantes

Lea todas las declaraciones de seguridad y precaución de este documento antes de realizar cualquiera de las instrucciones. Vea Intel Server Boards and Server Chassis Safety Information en el *Intel® Server Deployment Toolkit 2.0 CD* y/o en <http://support.intel.com/support/motherboards/server/sb/cs-010770.htm>.

重要安全指导

在执行任何指令之前，请阅读本文档中的所有注意事项及安全声明。和/或 <http://support.intel.com/support/motherboards/server/sb/CS-010770.htm> 上的 *Intel Server Boards and Server Chassis Safety Information* (《Intel 服务器主板与服务器机箱安全信息》)。

Warnings

Heed safety instructions: Before working with your server product, whether you are using this guide or any other resource as a reference, pay close attention to the safety instructions. You must adhere to the assembly instructions in this guide to ensure and maintain compliance with existing product certifications and approvals. Use only the described, regulated components specified in this guide. Use of other products / components will void the UL listing and other regulatory approvals of the product and will most likely result in noncompliance with product regulations in the region(s) in which the product is sold.

System power on/off: The power button DOES NOT turn off the system AC power. To remove power from system, you must unplug the AC power cord from the wall outlet. Make sure the AC power cord is unplugged before you open the chassis, add, or remove any components.

Hazardous conditions, devices and cables: Hazardous electrical conditions may be present on power, telephone, and communication cables. Turn off the server and disconnect the power cord, telecommunications systems, networks, and modems attached to the server before opening it. Otherwise, personal injury or equipment damage can result.

Electrostatic discharge (ESD) and ESD protection: ESD can damage disk drives, boards, and other parts. We recommend that you perform all procedures in this chapter only at an ESD workstation. If one is not available, provide some ESD protection by wearing an antistatic wrist strap attached to chassis ground any unpainted metal surface on your server when handling parts.

ESD and handling boards: Always handle boards carefully. They can be extremely sensitive to ESD. Hold boards only by their edges. After removing a board from its protective wrapper or from the server, place the board component side up on a grounded, static free surface. Use a conductive foam pad if available but not the board wrapper. Do not slide board over any surface.

Installing or removing jumpers: A jumper is a small plastic encased conductor that slips over two jumper pins. Some jumpers have a small tab on top that you can grip with your fingertips or with a pair of fine needle nosed pliers. If your jumpers do not have such a tab, take care when using needle nosed pliers to remove or install a jumper; grip the narrow sides of the jumper with the pliers, never the wide sides. Gripping the wide sides can damage the contacts inside the jumper, causing intermittent problems with the function controlled by that jumper. Take care to grip with, but not squeeze, the pliers or other tool you use to remove a jumper, or you may bend or break the pins on the board.

Preface

About this Manual

Thank you for purchasing and using the Intel® Server System SR1530CL / SR1530HCL / SR1530HCLS and/or the Intel® Server System SR1530CLR / SR1530HCLR / SR1530HCLSR.

This manual is written for system technicians who are responsible for troubleshooting, upgrading, and repairing this server system. This document provides reference information, feature information, and step by step instructions on how to add and replace components on the server system. For the latest version of this manual, see <http://support.intel.com/support/motherboards/server/chassis/S5000VCL/>.

Manual Organization

Chapter 1 provides an overview of the server system. In this chapter, you will find a list of the server system features, illustrations of the product, and product diagrams to help you identify components and their locations.

Chapter 2 provides instructions on using the utilities that are shipped with the board or that may be required to update the system. This includes how to navigate through the BIOS Setup screens, how to perform a BIOS update, and how to reset the password or CMOS. Information about the specific BIOS settings and screens is available in the *Intel® Server Board S5000VCL Technical Product Specification*. See “[Server System References](#)” on [page ix](#) for a link to the Technical Product Specification.

Chapter 3 provides instructions on adding and replacing components. Use this chapter for step-by-step instructions and diagrams for installing or replacing components such as the fans, power supply, drives, and other components.

At the back of this manual, you will find technical specifications, troubleshooting information, complete safety information, regulatory information, "getting help" information, and the warranty.

Product Contents

The Intel® Server System SR1530CL / SR1530HCL / SR1530HCLS ships with the Intel® Server Board S5000VCL.

The Intel® Server System SR1530CLR / SR1530HCLR / SR1530HCLSR ships with the Intel® Server Board S5000VCLR.

Intel® Server System Contents

Your Intel® Server System SR1530CL / SR1530HCL / SR1530HCLS and/or the Intel® Server System SR1530CLR / SR1530HCLR / SR1530HCLSR ships with the following items:

- One Intel® Server Board S5000VCL/S5000VCLR, installed in the server system
- One 400-watt power supply module, installed in the server system
- One low-profile riser, installed in the server system
- Two system blowers, with attached cables, installed in the server system
- (SR1530CL/SR1530CLR) One PCI cooling fan
- (SR1530HCL/SR1530HCLR) One PCI cooling baffle
- (SR1530CL/SR1530CLR) One hard disk drive 0 bracket
- (SR1530CL/SR1530CLR) One hard disk drive 1 bracket
- One slimline optical drive installation kit, in the server system product box
- (SR1530CL/SR1530CLR) Screws:
 - 24 6-32 flat-head screws for attaching the slimline optical drive and hard disk drives to the chassis, and for attaching hard disk drives to the hard disk drive brackets
 - One 6-32 pan-head screw for the hard disk drive attached to the chassis
 - Four M1.5 screws for attaching the brackets to the slimline optical drive
 - Two M2 screws for attaching the interposer board to the slimline optical drive
- (SR1530HCL/SR1530HCLR) Screws:
 - 24 6-32 flat-head screws for attaching the hard disk drives to the drive carriers
 - Two M1.5 screws for attaching the bracket to the slimline optical drive
 - Two M2 screws for attaching the interposer board to the slimline optical drive
- Rack handles, in the server system product box
- One control panel, installed in the server system
- One rail kit, in a separate box
- One CD kit
- One Quick Start User's Guide
- One Attention document

- (SR1530CL/SR1530CLR) Cables:
 - Two SATA cables, in the server system product box
 - One IDE cable, in the server system product box
 - One front panel cable, installed in the server system
- (SR1530HCL/SR1530HCLR) Cables
 - Three SAS/SATA cables, installed in the system
 - One IDE cable, in the server system product box
 - One front panel cable, installed in the server system
 - One USB front panel cable, installed in the server system
 - One SGPIO cable, installed in the server system

Server System References

If you need more information about this product or information about the accessories that can be used with this server system, use the following resources.

| For this Information or Software | Use this Document or Software |
|---|---|
| Technical information about the server chassis, including sub-system overviews and mechanical drawings | <i>Intel® Server Chassis SR1530 Technical Product Specification</i> Found at: http://support.intel.com/support/motherboards/server/S5000VCL/ |
| Technical information about the server board, including board layout, connector pin-outs, timing information, mechanical drawings and LED information | <i>Intel® Server Board S5000VCL Technical Product Specification</i> Found at: http://support.intel.com/support/motherboards/server/S5000VCL/ |
| If you just received this product and need to install it | <i>Intel® Server System SR1530CL / SR1530HCL / SR1530HCLS Quick Start User's Guide</i> <i>Intel® Server System SR1530CLR / SR1530HCLR / SR1530HCLSR Quick Start User's Guide</i> Found in the product box |
| Accessories or other Intel server products | <i>Spares and Configuration Guide</i> Found at: available from your Intel field representative or on the Server Configurator Tool at http://indigo.intel.com/serverconfigurortool/default.aspx |

| For this Information or Software | Use this Document or Software |
|---|---|
| Hardware (peripheral boards, adapter cards) and operating systems that have been tested with this product | <p><i>Tested Hardware Operating Systems List</i></p> <p>Found at: http://support.intel.com/support/motherboards/server/S5000VCL/</p> |
| For software to manage your Intel® server | <p>Intel® System Management</p> <p>Found at: http://support.intel.com/support/motherboards/server/S5000VCL/</p> |
| For diagnostics test software | <p>Diagnostics</p> <p>Found at: http://support.intel.com/support/motherboards/server/S5000VCL/</p> |

Contents

| | |
|---|------------|
| Safety Information | iii |
| Important Safety Instructions | iii |
| Wichtige Sicherheitshinweise | iii |
| Consignes de sécurité | iii |
| Instrucciones de seguridad importantes | iii |
| Warnings | v |
| Preface | vii |
| About this Manual | vii |
| Manual Organization | vii |
| Product Contents | vii |
| Intel® Server System Contents | viii |
| Server System References | ix |
| Chapter 1: Server System Features | 1 |
| Chassis Component Identification | 4 |
| Front Control Panel (SR1530CL/SR1530CLR) | 4 |
| Front Control Panel (SR1530HCL/SR1530HCLS and SR1530HCLR/SR1530HCLSR) | 5 |
| System Rear | 6 |
| Peripheral Devices | 7 |
| Internal Components | 10 |
| Configuration Jumpers | 13 |
| RAID Support | 14 |
| Rack-Mounted Systems | 14 |
| Hardware Requirements | 15 |
| Processor | 15 |
| Memory | 15 |
| Chapter 2: Server Utilities | 17 |
| Using the BIOS Setup Utility | 17 |
| Starting Setup | 17 |
| If You Cannot Access Setup | 17 |
| Setup Menus | 17 |
| Upgrading the BIOS | 19 |
| Preparing for the Upgrade | 19 |
| Upgrading the BIOS | 20 |
| Clearing the Password | 21 |
| Clearing the CMOS | 22 |
| Forcing a BMC Update | 23 |
| Chapter 3: Hardware Installations and Upgrades | 25 |

| | |
|---|----|
| Before You Begin | 25 |
| Tools and Supplies Needed | 25 |
| System References | 25 |
| Removing and Installing the Front Bezel | 26 |
| Removing the Front Bezel | 26 |
| Installing the Front Bezel | 27 |
| Removing and Installing the Server Cover | 28 |
| Removing the Server System Cover | 28 |
| Installing the Server System Cover | 30 |
| Removing and Installing the Processor Air Duct | 32 |
| Removing the Processor Air Duct | 32 |
| Installing the Processor Air Duct | 33 |
| Installing and Removing Memory | 35 |
| Installing DIMMs | 35 |
| Removing DIMMs | 37 |
| Installing or Replacing the Processor | 37 |
| Installing the Processor | 37 |
| Installing the Heat Sink | 40 |
| Removing the Heat Sink and Processor | 41 |
| Installing and Removing a Hard Drive (SR1530CL/SR1530CLR) | 42 |
| Installing a Hard Disk Drive (SR1530CL/SR1530CLR) | 42 |
| Removing a Hard Disk Drive (SR1530CL/SR1530CLR) | 46 |
| Installing and Removing a Hot-Swap SAS/SATA Drive (SR1530HCL/SR1530HCLS and SR1530HCLR/SR1530HCLSR) | 47 |
| Installing a Hot-Swap SAS/SATA Drive (SR1530HCL/SR1530HCLS and SR1530HCLR/SR1530HCLSR) | 48 |
| Removing a Hot-Swap SAS/SATA Drive (SR1530HCL/SR1530HCLS and SR1530HCLR/SR1530HCLSR) | 50 |
| Installing or Removing a Slimline Optical Drive | 51 |
| Installing a Slimline Optical Drive (SR1530CL/SR1530CLR) | 51 |
| Installing a Slimline Optical Drive (SR1530HCL/SR1530HCLS and SR1530HCLR/SR1530HCLSR) | 55 |
| Removing a Slimline Optical Drive (SR1530CL/SR1530CLR) | 58 |
| Removing a Slimline Optical Drive (SR1530HCL/SR1530HCLS and SR1530HCLR/SR1530HCLSR) | 61 |
| Installing and Removing the PCI Riser Assembly | 63 |
| Removing the PCI Riser Assembly | 63 |
| Installing the PCI Riser Assembly | 64 |
| Installing or Replacing a PCI Riser Card | 65 |
| Installing a PCI Riser Card | 65 |
| Replacing a PCI Riser Card | 66 |
| Installing or Removing a PCI Add-in Card | 67 |
| Installing a PCI Add-in Card | 67 |
| Removing a PCI Add-in Card | 68 |

| | |
|--|------------|
| Installing and Removing the Server Board | 69 |
| Installing the Server Board | 69 |
| Removing the Server Board | 71 |
| Replacing the CMOS Battery | 72 |
| Replacing the Power Supply (SR1530CL/SR1530CLR) | 73 |
| Replacing the Power Supply (SR1530HCL/SR1530HCLS and SR1530HCLR/ SR1530HCLSR) | 78 |
| Replacing the Front Panel Board (SR1530CL/SR1530CLR) | 83 |
| Replacing the Front Panel Board (SR1530HCL/SR1530HCLR) | 85 |
| Replacing a System Blower | 88 |
| Replacing the System Blowers (SR1530CL/SR1530CLR) | 88 |
| Replacing a System Blower (SR1530HCL/SR1530HCLS and SR1530HCLR/ SR1530HCLSR) | 91 |
| Replacing the PCI Cooling Fan (SR1530CL/SR1530CLR) | 93 |
| Installing and Removing the Rack Handles | 95 |
| Installing the Rack Handles | 95 |
| Removing the Rack Handles | 96 |
| Appendix A: Technical Reference | 97 |
| Cable Routing | 97 |
| Power Cable Routing (SR1530CL/SR1530CLR) | 98 |
| Power Cable Routing (SR1530HCL/SR1530HCLS and SR1530HCLR/SR1530HCLSR) 99 | |
| Data Cable Routing (SR1530CL/SR1530CLR) | 100 |
| Data Cable Routing (SR1530HCL/SR1530HCLS and SR1530HCLR/SR1530HCLSR) . 101 | |
| 400-W Single Power Supply Input Voltages | 102 |
| 400-W Single Power Supply Output Voltages | 102 |
| System Environmental Specifications | 103 |
| Appendix B: Troubleshooting | 105 |
| Resetting the System | 105 |
| Problems following Initial System Installation | 106 |
| First Steps Checklist | 106 |
| Hardware Diagnostic Testing | 107 |
| Verifying Proper Operation of Key System Lights | 107 |
| Confirming Loading of the Operating System | 107 |
| Specific Problems and Corrective Actions | 108 |
| Power Light Does Not Light | 108 |
| No Characters Appear on Screen | 109 |
| Characters Are Distorted or Incorrect | 110 |
| System Cooling Fans Do Not Rotate Properly | 110 |
| Drive Activity Light Does Not Light | 110 |
| CD-ROM Drive or DVD-ROM Drive Activity Light Does Not Light | 111 |
| Cannot Connect to a Server | 111 |

| | |
|---|------------|
| Problems with Network | 111 |
| System Boots when Installing PCI Card | 112 |
| Problems with Newly Installed Application Software | 112 |
| Problems with Application Software that Ran Correctly Earlier | 113 |
| Devices are not Recognized under Device Manager (Microsoft Windows* Operating System) | 113 |
| Hard Drive(s) are not Recognized | 113 |
| Bootable CD-ROM Disk Is Not Detected | 114 |
| LED Information | 114 |
| BIOS POST Beep Codes | 116 |
| Appendix C: Getting Help | 117 |
| World Wide Web | 117 |
| Telephone | 117 |
| Appendix D: Safety Information | 121 |
| English | 121 |
| Server Safety Information | 121 |
| Safety Warnings and Cautions | 121 |
| Intended Application Uses | 122 |
| Site Selection | 122 |
| Equipment Handling Practices | 122 |
| Power and Electrical Warnings | 123 |
| System Access Warnings | 124 |
| Rack Mount Warnings | 124 |
| Electrostatic Discharge (ESD) | 125 |
| Other Hazards | 125 |
| Deutsch | 126 |
| Sicherheitshinweise für den Server | 126 |
| Sicherheitshinweise und Vorsichtsmaßnahmen | 126 |
| Zielbenutzer der Anwendung | 127 |
| Standortauswahl | 127 |
| Handhabung von Geräten | 127 |
| Warnungen zu Netzspannung und Elektrizität | 128 |
| Warnhinweise für den Systemzugang | 129 |
| Warnhinweise für Racks | 129 |
| Elektrostatische Entladungen (ESD) | 130 |
| Andere Gefahren | 130 |
| Français | 131 |
| Consignes de securite sur le serveur | 131 |
| Séurité: avertissements et mises en garde | 131 |
| Domaines d'utilisation prévus | 132 |
| Sélection d'un emplacement | 132 |
| Pratiques de manipulation de l'équipement | 133 |
| Alimentation et avertissements en matière d'électricité | 133 |

| | |
|--|------------|
| Avertissements sur le cordon d'alimentation | 134 |
| Avertissements sur l'accès au système | 134 |
| Avertissements sur le montage en rack | 135 |
| Décharges électrostatiques (ESD) | 136 |
| Autres risques | 136 |
| Périphériques laser | 137 |
| Español | 137 |
| Información de seguridad del servidor | 137 |
| Advertencias y precauciones sobre seguridad | 137 |
| Aplicaciones y usos previstos | 138 |
| Selección de la ubicación | 138 |
| Manipulación del equipo | 139 |
| Advertencias de alimentación y eléctricas | 139 |
| Advertencias sobre el cable de alimentación | 139 |
| Advertencias el acceso al sistema | 140 |
| Advertencias sobre el montaje en bastidor | 142 |
| Descarga electrostática (ESD) | 142 |
| Otros riesgos | 143 |
| Appendix E: Installation / Assembly Safety Instructions | 145 |
| English | 145 |
| Deutsch | 147 |
| Français | 149 |
| Español | 151 |
| Italiano | 153 |
| Appendix F: Regulatory and Compliance Information | 157 |
| Product Regulatory Compliance | 157 |
| Product Safety Compliance | 157 |
| Product Regulatory Compliance References | 158 |
| Electromagnetic Compatibility Notices | 161 |
| FCC Verification Statement (USA) | 161 |
| Industry Canada (ICES-003) | 162 |
| Europe (CE Declaration of Conformity) | 162 |
| VCCI (Japan) | 162 |
| BSMI (Taiwan) | 162 |
| Korean Compliance (RRL) | 163 |
| Product Ecology Compliance | 163 |
| Other Markings | 166 |
| Regulated Specified Components | 167 |
| End-of-Life / Product Recycling | 168 |
| Appendix G: Warranty | 169 |
| Limited Warranty for Intel® Chassis Subassembly Products | 169 |

List of Tables

| | |
|--|-----|
| Table 1. Intel® Server System SR1530CL / SR1530HCL / SR1530HCLS and Intel Server System SR1530CLR / SR1530HCLR / SR1530HCLSR Feature Summary | 2 |
| Table 2. NIC LED Descriptions | 6 |
| Table 3. Setup Menu Key Use | 18 |
| Table 4. Power Supply Output Capability | 102 |
| Table 5. System Environmental Specifications | 103 |
| Table 6. Resetting the System | 105 |
| Table 7. LED Information | 114 |
| Table 8. System Status LED Color and Blink Codes | 115 |
| Table 9. POST Error Beep Codes | 116 |
| Table 10. Error Beep Codes Generated by Intel® Remote Management Module | 116 |
| Table 11. Product Regulatory Compliance Markings | 158 |
| Table 12. Product Ecology Compliance Markings | 164 |
| Table 13. Other Markings | 166 |

List of Figures

| | |
|---|----|
| Figure 1. Intel® Server System SR1530CL/SR1530CLR | 1 |
| Figure 2. Intel® Server System SR1530HCL / SR1530HCLS and SR1530HCLR / SR1530HCLSR | 1 |
| Figure 3. Front Controls and LEDs (SR1530CL/SR1530CLR) | 4 |
| Figure 4. Front Controls and LEDs (SR1530HCL/SR1530HCLS and SR1530HCLR/ SR1530HCLSR)..... | 5 |
| Figure 5. Back Panel Connectors..... | 6 |
| Figure 6. Optional Peripherals (SR1530CL/SR1530CLR) | 7 |
| Figure 7. Optional Peripherals (SR1530HCL/SR1530HCLS and SR1530HCLR/SR1530HCLSR) | 8 |
| Figure 8. Chassis Components (SR1530CL/SR1530CLR)..... | 10 |
| Figure 9. Chassis Components (SR1530HCL/SR1530HCLS and SR1530HCLR/ SR1530HCLSR)..... | 11 |
| Figure 10. Server Board Connector and Component Locations | 12 |
| Figure 11. Configuration Jumpers..... | 13 |
| Figure 12. Identifying DIMM Sockets | 15 |
| Figure 13. Clear Password Jumper..... | 21 |
| Figure 14. Clear CMOS Jumper..... | 22 |
| Figure 15. BMC Force Update Jumper | 23 |
| Figure 16. Removing the Front Bezel (SR1530CL/SR1530CLR) | 26 |
| Figure 17. Removing the Front Bezel (SR1530HCL/SR1530HCLS and SR1530HCLR/ SR1530HCLSR)..... | 27 |
| Figure 18. Installing the Front Bezel (SR1530CL/SR1530CLR) | 27 |
| Figure 19. Installing the Front Bezel (SR1530HCL/SR1530HCLS and SR1530HCLR/ SR1530HCLSR)..... | 28 |
| Figure 20. Removing the Server System Cover (SR1530CL/SR1530CLR)..... | 29 |
| Figure 21. Removing the Server System Cover (SR1530HCL/SR1530HCLS and SR1530HCLR/ SR1530HCLSR)..... | 30 |
| Figure 22. Installing the Server System Cover (SR1530CL/SR1530CLR)..... | 31 |
| Figure 23. Installing the Server System Cover (SR1530HCL/SR1530HCLS and SR1530HCLR/ SR1530HCLSR)..... | 31 |
| Figure 24. Removing the Processor Air Duct (SR1530CL/SR1530CLR)..... | 32 |
| Figure 25. Removing the Processor Air Duct (SR1530HCL/SR1530HCLS and SR1530HCLR/ SR1530HCLSR)..... | 33 |
| Figure 26. Installing the Processor Air Duct (SR1530CL/SR1530CLR)..... | 34 |
| Figure 27. Installing the Processor Air Duct (SR1530HCL/SR1530HCLS and SR1530HCLR/ SR1530HCLSR)..... | 34 |
| Figure 28. Installing the Memory..... | 36 |
| Figure 29. Lifting the Processor Socket Handle | 38 |
| Figure 30. Opening the Load Plate | 38 |
| Figure 31. Removing the Shipping Cover | 39 |
| Figure 32. Installing the Processor..... | 39 |

| | |
|---|----|
| Figure 33. Removing the Protective Socket Cover | 40 |
| Figure 34. Installing the Heat Sink | 41 |
| Figure 35. Locating Drive Positions (SR1530CL/SR1530CLR) | 43 |
| Figure 36. Removing Drive Carrier from Server System (SR1530CL/SR1530CLR) | 43 |
| Figure 37. Installing Drive into Drive Carrier (SR1530CL/SR1530CLR)..... | 44 |
| Figure 38. Install Drive Assembly into Server System (SR1530CL/SR1530CLR)..... | 44 |
| Figure 39. Connecting Hard Drive Power and Data Cables (SR1530CL/SR1530CLR) | 45 |
| Figure 40. Removing Drive Carrier from the Server System (SR1530CL/SR1530CLR) | 46 |
| Figure 41. Install Drive Assembly into the Server System (SR1530CL/SR1530CLR)..... | 47 |
| Figure 42. Locating Drive Positions (SR1530HCL/SR1530HCLS and SR1530HCLR/ SR1530HCLSR) | 48 |
| Figure 43. Removing the Drive Carrier (SR1530HCL/SR1530HCLS and SR1530HCLR/ SR1530HCLSR) | 48 |
| Figure 44. Installing Drive into Drive Carrier (SR1530HCL/SR1530HCLS and SR1530HCLR/ SR1530HCLSR) | 49 |
| Figure 45. Installing Drive Assembly into Server System (SR1530HCL/SR1530HCLS and SR1530HCLR/SR1530HCLSR)..... | 50 |
| Figure 46. Lifting PCI Cooling Fan from Mounting Pegs (SR1530CL/SR1530CLR) | 52 |
| Figure 47. Removing the Knockout in Bezel for Optical Drive Opening (SR1530CL/SR1530CLR) 52 | |
| Figure 48. Attaching the Interposer Board (SR1530CL/SR1530CLR)..... | 53 |
| Figure 49. Attaching the Brackets to the Optical Drive (SR1530CL/SR1530CLR) | 53 |
| Figure 50. Installing the Optical Drive into the Server System (SR1530CL/SR1530CLR) | 54 |
| Figure 51. Installing PCI Cooling Fan (SR1530CL/SR1530CLR) | 54 |
| Figure 52. Attaching the Interposer Board (SR1530HCL/SR1530HCLS and SR1530HCLR/ SR1530HCLSR) | 55 |
| Figure 53. Attaching the Bracket to the Optical Drive (SR1530HCL/SR1530HCLS and SR1530HCLR/SR1530HCLSR)..... | 56 |
| Figure 54. Installing the Optical Drive into the System (SR1530HCL/SR1530HCLS and SR1530HCLR/SR1530HCLSR)..... | 56 |
| Figure 55. Routing Data and Power Cables to Optical Drive (SR1530HCL/SR1530HCLS and SR1530HCLR/SR1530HCLSR)..... | 57 |
| Figure 56. Lifting PCI Cooling Fan from Mounting Pegs (SR1530CL/SR1530CLR) | 58 |
| Figure 57. Removing the Optical Drive from the Server System (SR1530CL/SR1530CLR) .. | 59 |
| Figure 58. Removing the Brackets from the Optical Drive Bracket (SR1530CL/SR1530CLR) .. | 59 |
| Figure 59. Removing the Interposer Board from the Optical Drive (SR1530CL/SR1530CLR) .. | 60 |
| Figure 60. Installing the PCI Cooling Fan onto Mounting Pegs (SR1530CL/SR1530CLR) | 60 |
| Figure 61. Removing Optical Drive from Server System (SR1530HCL/SR1530HCLS and SR1530HCLR/SR1530HCLSR)..... | 61 |
| Figure 62. Removing Bracket from Optical Drive Bracket (SR1530HCL/SR1530HCLS and SR1530HCLR/SR1530HCLSR)..... | 62 |
| Figure 63. Removing Interposer Board from Optical Drive (SR1530HCL/SR1530HCLS and SR1530HCLR/SR1530HCLSR)..... | 62 |
| Figure 64. Removing PCI Riser Assembly from the Server System..... | 63 |
| Figure 65. Installing PCI Riser Assembly into the Server System | 64 |
| Figure 66. Installing Riser Card onto Riser Assembly | 65 |
| Figure 67. Removing Riser Card from Riser Assembly | 66 |

| | |
|--|-----|
| Figure 68. Installing an Add-In Card..... | 68 |
| Figure 69. Removing an Add-In Card..... | 69 |
| Figure 70. Installing the Server Board..... | 70 |
| Figure 71. Removing the Server Board..... | 71 |
| Figure 72. Replacing the CMOS Battery | 73 |
| Figure 73. Disconnecting Power Cables (SR1530CL/SR1530CLR)..... | 74 |
| Figure 74. Removing Power Supply from the Server System (SR1530CL/SR1530CLR)..... | 75 |
| Figure 75. Installing Power Supply into the Server System (SR1530CL/SR1530CLR)..... | 76 |
| Figure 76. Connecting Power Cables (SR1530CL/SR1530CLR) | 77 |
| Figure 77. Disconnecting Power Cables (SR1530HCL/SR1530HCLS and SR1530HCLR/ SR1530HCLSR)..... | 79 |
| Figure 78. Removing Power Supply from Server System (SR1530HCL/SR1530HCLS and SR1530HCLR/SR1530HCLSR) | 80 |
| Figure 79. Installing Power Supply into Server System (SR1530HCL/SR1530HCLS and SR1530HCLR/SR1530HCLSR) | 81 |
| Figure 80. Connecting Power Cables (SR1530HCL/SR1530HCLS and SR1530HCLR/ SR1530HCLSR)..... | 82 |
| Figure 81. Removing Front Panel Board from Server System (SR1530CL/SR1530CLR)..... | 83 |
| Figure 82. Installing Front Panel Board in Server System (SR1530CL/SR1530CLR) | 84 |
| Figure 83. Removing Front Panel Board from Server System (SR1530HCL/SR1530HCLR). | 85 |
| Figure 84. Removing Light Pipes from Front Panel Board..... | 86 |
| Figure 85. Installing Light Pipes on Replacement Front Panel Board..... | 86 |
| Figure 86. Installing Front Panel Board into Server System (SR1530HCL/SR1530HCLR).... | 87 |
| Figure 87. Disconnecting System Blower Cables (SR1530CL/SR1530CLR) | 88 |
| Figure 88. Removing Blower Bracket with System Blowers from Server System (SR1530CL/ SR1530CLR)..... | 89 |
| Figure 89. Removing System Blower from Blower Bracket (SR1530CL/SR1530CLR) | 90 |
| Figure 90. Connecting System Blower Cables (SR1530CL/SR1530CLR)..... | 91 |
| Figure 91. Removing System Blower from Server System (SR1530HCL/SR1530HCLS and SR1530HCLR/SR1530HCLSR) | 92 |
| Figure 92. Installing System Blower in Server System (SR1530HCL/SR1530HCLS and SR1530HCLR/SR1530HCLSR) | 93 |
| Figure 93. Disconnecting the PCI Cooling Fan (SR1530CL/SR1530CLR)..... | 94 |
| Figure 94. Removing the PCI Cooling Fan (SR1530CL/SR1530CLR) | 94 |
| Figure 95. Installing the Rack Handle | 95 |
| Figure 96. Removing the Rack Handle | 96 |
| Figure 97. Power Cable Routing (SR1530CL/SR1530CLR)..... | 98 |
| Figure 98. Power Cable Routing (SR1530HCL/SR1530HCLS and SR1530HCLR/ SR1530HCLSR)..... | 99 |
| Figure 99. Data Cable Routing (SR1530CL/SR1530CLR)..... | 100 |
| Figure 100. Data Cable Routing (SR1530HCL/SR1530HCLS and SR1530HCLR/ SR1530HCLSR)..... | 101 |

1 Server System Features

This chapter briefly describes the main features of the server system. This chapter provides a illustrations of the product, a list of the server system features, and diagrams showing the location of important components and connections on the server system.



Figure 1. Intel® Server System SR1530CL/SR1530CLR



Figure 2. Intel® Server System SR1530HCL / SR1530HCLS and SR1530HCLR / SR1530HCLSR

Table 1 summarizes the features of the server system.

Table 1. Intel® Server System SR1530CL / SR1530HCL / SR1530HCLS and Intel Server System SR1530CLR / SR1530HCLR / SR1530HCLSR Feature Summary

| Feature | Description |
|--|--|
| Dimensions (SR1530CL/ SR1530CLR) | <ul style="list-style-type: none"> • 1.69 inches high (4.29 centimeters) • 17 inches wide (43.18 centimeters) • 20 inches deep (50.80 centimeters) • 22 pounds |
| Dimensions (SR1530HCL/ SR1530HCLS and SR1530HCLR/ SR1530HCLSR) | <ul style="list-style-type: none"> • 1.70 inches high (4.325 centimeters) • 16.92 inches wide (43.0 centimeters) • 25.51 inches deep (64.80 centimeters), excluding hard drive carrier, front control panel bezel, rack handles, and front bezel • 23 pounds |
| Server Board | One Intel® Server Board S5000VCL/S5000VCLR |
| Processor | Support for up to two Dual-Core Intel® Xeon® processors 5100 series or 5300 (80-W versions only) series with a 1333 or 1066 MHz front side bus |
| Memory | <ul style="list-style-type: none"> • Memory mirroring and memory sparing options • Six slots supporting FBDIMM 667-MHz memory • 12 GB maximum memory |
| Chipset | Intel® 5000V Chipset, consisting of <ul style="list-style-type: none"> • Intel® 5000V Memory Controller Hub • Intel® 6321ESB I/O Controller Hub |
| Peripheral Interfaces | <p>External connections:</p> <ul style="list-style-type: none"> • Stacked PS/2 ports for keyboard and mouse • DB9 Serial A port • Two NIC connectors for 10/100/1000 Mb connections • Two USB 2.0 ports <p>Internal connections:</p> <ul style="list-style-type: none"> • One USB port header, which supports two USB 2.0 ports • (SR1530CL/SR1530HCL) Six SATA-150 connectors with integrated RAID 0/1/10 support • (SR1530HCLS) Four SAS connectors and two SATA connectors • One ATA-100 connector • SSI-compliant 24-pin control panel header |
| I/O Control | SMSC* SCH5027 controller |
| Video | On-board ATI* RAGE video controller with 16 MB SDRAM |
| LAN | <ul style="list-style-type: none"> • Intel® 10/100/1000 82573E Gigabit Ethernet Controller • Intel® 10/100/1000 82541PI Gigabit Ethernet Controller |

Table 1. Intel® Server System SR1530CL / SR1530HCL / SR1530HCLS and Intel Server System SR1530CLR / SR1530HCLR / SR1530HCLSR Feature Summary

| Feature | Description |
|--------------------------------------|---|
| Expansion Capabilities | <ul style="list-style-type: none"> • Supports one full-height PCI-X* card and one low-profile PCIe* card |
| Hard Drives | <ul style="list-style-type: none"> • ATA-100 support: one IDE channel • SATA support |
| Peripherals | <ul style="list-style-type: none"> • Slimline bay for IDE optical drive (optional) |
| Front control panel LEDs and buttons | <ul style="list-style-type: none"> • NIC1 Activity • NIC2 Activity • Power / Sleep • System Status • Hard Drive Activity |
| Power Supply | One 400-watt power supply module |
| Fans | <ul style="list-style-type: none"> • Non-redundant fans: <ul style="list-style-type: none"> – (SR1530CL/SR1530CLR) One PCI cooling fan – Two system blowers |
| USB | <ul style="list-style-type: none"> • One front panel USB port • One internal USB header providing two USB ports |
| System Management | Intel® System Management Software |

Chassis Component Identification

This section helps you identify the components of your server system. If you are near the system, you can also use the Quick Reference Label provided on the inside of the chassis cover to assist in identifying components.

Front Control Panel (SR1530CL/SR1530CLR)

The front control panel of the Intel® Server System SR1530CL/SR1530CLR includes the following buttons and LEDs.

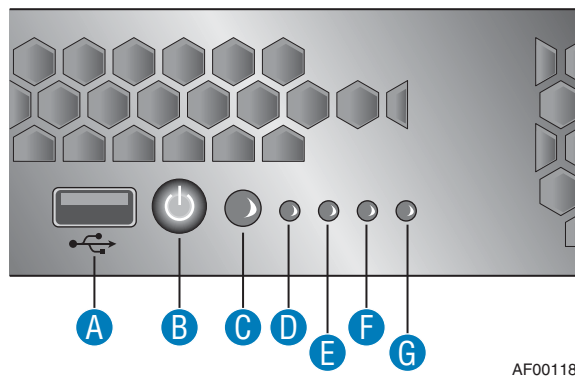

| | |
|----------------------|---------------------------------|
| A. USB Port | E. Hard Disk Drive Activity LED |
| B. Power Button | F. NIC1 LED |
| C. System Status LED | G. NIC2 LED |
| D. System Power LED | |

Figure 3. Front Controls and LEDs (SR1530CL/SR1530CLR)

Front Control Panel (SR1530HCL/SR1530HCLS and SR1530HCLR/SR1530HCLSR)

The front control panel of the Intel® Server System SR1530HCL / SR1530HCLS and SR1530HCLR / SR1530HCLSR includes the following buttons and LEDs.

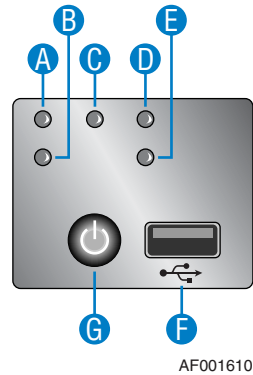

| | |
|----------------------|---------------------------------|
| A. NIC1 LED | E. Hard Disk Drive Activity LED |
| B. NIC2 LED | F. USB Port |
| C. System Power LED | G. Power Button |
| D. System Status LED | |

Figure 4. Front Controls and LEDs (SR1530HCL/SR1530HCLS and SR1530HCLR/SR1530HCLSR)

System Rear

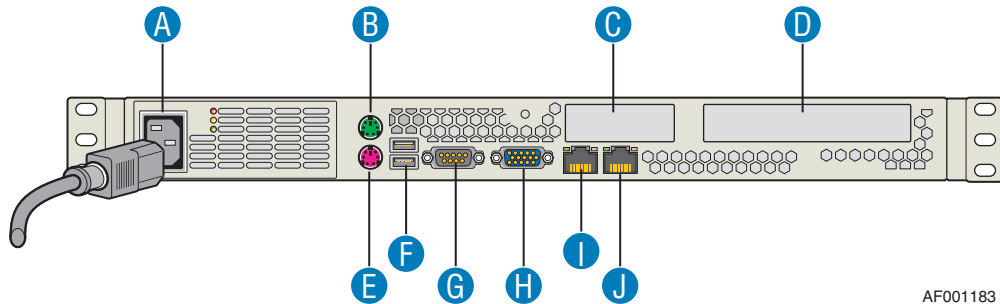

| | |
|---------------------------|---------------------------|
| A. AC Power Connector | F. USB 0-1 |
| B. Mouse Socket | G. Serial Port A |
| C. PCI Express* Slot | H. Video |
| D. Full-height PCI-X Slot | I. NIC 1 (10/100/1000 Mb) |
| E. Keyboard Socket | J. NIC 2 (10/100/1000 Mb) |

Figure 5. Back Panel Connectors

The NIC LEDs at the right and left of each NIC provide the following information.

Table 2. NIC LED Descriptions

| LED | LED State | Description |
|-------|----------------|--|
| Left | Off | No network connection |
| | Solid Amber | Network connection in place |
| | Blinking Amber | Transmit/receive activity |
| Right | Off | 10 Mbps connection (if left LED is on or blinking) |
| | Solid Amber | 100 Mbps connection |
| | Solid Green | 1000 Mbps connection |

Peripheral Devices

The server system provides locations and hardware for installing hard drives, CD-ROM drive, or DVD-ROM drive. The drives must be purchased separately. The following figure shows the available options.

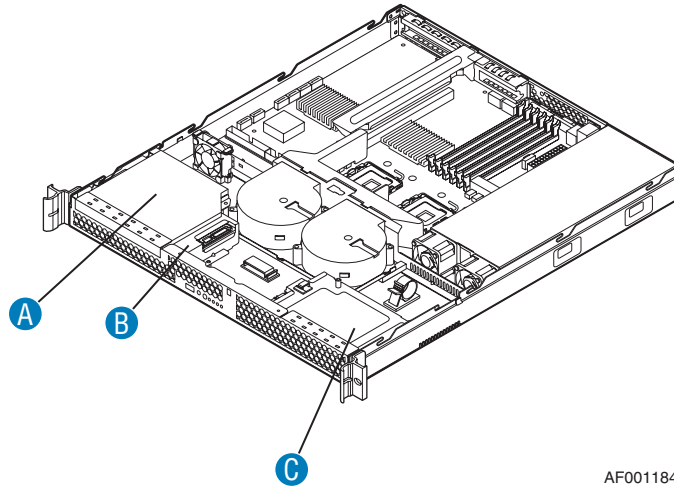

AF001184

-
- A. Slimline Optical Drive Bay

 - B. Hard Disk Drive Bay HDD0 (located under the slimline optical drive bay)

 - C. Hard Disk Drive Bay HDD1

Figure 6. Optional Peripherals (SR1530CL/SR1530CLR)

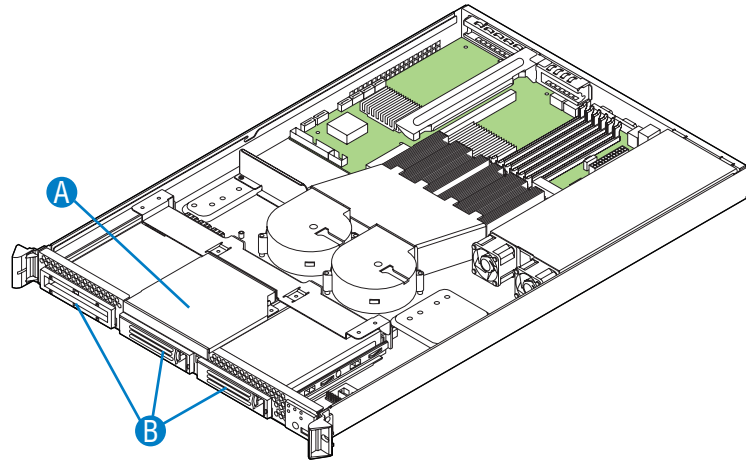

AF001611

A. Slimline Optical Drive Bay (CD/DVD)

B. Hard Disk Drive Bay (3)

Figure 7. Optional Peripherals (SR1530HCL/SR1530HCLS and SR1530HCLR/SR1530HCLSR)

Hard Disk Drives

The Intel® Server System SR1530CL/SR1530CLR and Intel® Server System SR1530HCL/SR1530HCLR provide six SATA ports and one IDE connection. The six SATA ports are located near the front left side of the server board. An IDE device can be connected to the standard IDE connector located near the SATA ports.

The Intel® Server System SR1530HCLS/SR1530HCLSR provides two SATA and four SAS ports as well as one IDE connection. The two SATA and four SAS ports are located near the front left side of the server board. An IDE device can be connected to the standard IDE connector located near the SATA ports.

Note: *Drives can consume up to 17 watts of power each. Drives must be specified to run at a maximum ambient temperature of 45° C.*

Note: *The Intel® Server System SR1530CL / SR1530HCL / SR1530HCLS and the Intel® Server System SR1530CLR / SR1530HCLR / SR1530HCLSR do not support all SAS/SATA hard drives. See “[Server System References](#)” on page ix for an Internet link to a list of supported hardware.*

Slimline Optical Drive

One slimline drive carrier is included with your server system; the optical drive must be purchased separately.

Note: *The Intel® Server System SR1530CL / SR1530HCL / SR1530HCLS and the Intel® Server System SR1530CLR / SR1530HCLR / SR1530HCLSR do not support all slimline optical drives. See “[Server System References](#)” on page ix for an Internet link to a list of supported hardware. Intel provides accessory kits for these drives.*

For installation instructions for an optical drive, see “[Installing or Removing a Slimline Optical Drive](#)” on page 51.

Internal Components

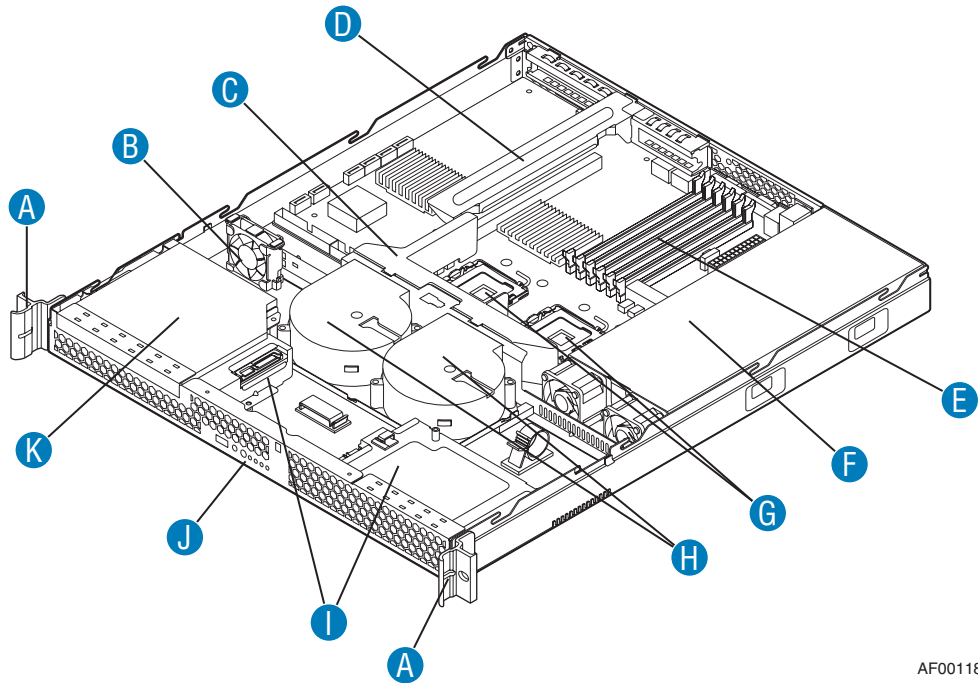

AF001185

| | |
|-------------------------------|-------------------------------|
| A. Rack Handles (two) | G. Processor Sockets (two) |
| B. PCI Cooling Fan | H. System Blowers (two) |
| C. Processor Air Duct | I. Hard Drive Brackets (two) |
| D. PCI Add-in Card Bracket | J. Control Panel |
| E. System Memory DIMM Sockets | K. Slimline Optical Drive Bay |
| F. Power Supply | |

Figure 8. Chassis Components (SR1530CL/SR1530CLR)

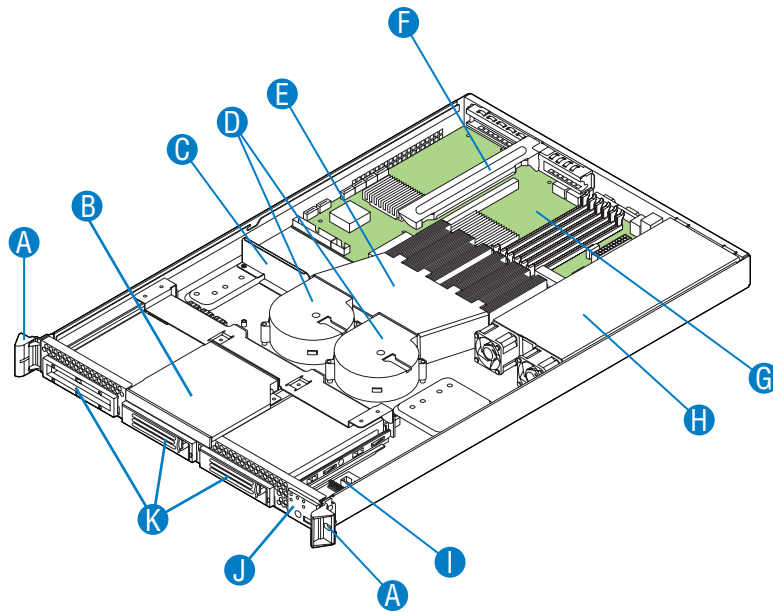

AF001612

| | |
|-------------------------------|-------------------------|
| A. Rack Handles (two) | G. Server Board |
| B. Slimline Optical Drive Bay | H. Power Supply |
| C. PCI Cooling Baffle | I. Control Panel Board |
| D. System Blowers (2) | J. Control Panel |
| E. Processor Air Duct | K. Hard Disk Drives (3) |
| F. PCI Add-in Card Bracket | |

Figure 9. Chassis Components (SR1530HCL/SR1530HCLS and SR1530HCLR/SR1530HCLSR)

Server Board Connector and Component Locations

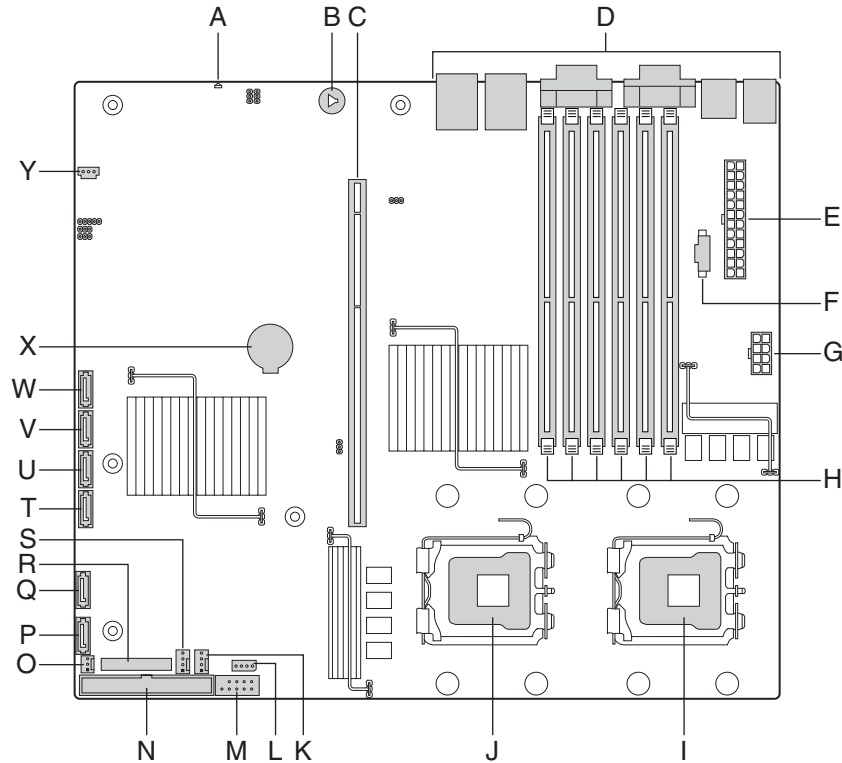

AF000646

| | | |
|---|----------------------------------|---|
| A. Status LED | J. Processor 2 Socket | S. Processor 1 Fan |
| B. On-board Speaker | K. Processor 2 Fan | T. SATA 2 (SAS 0 in SR1530HCLS/ SR1530HCLSR) |
| C. Slot 6 Riser PCIe* x8 or PCI-X* 133 | L. SGPIO SATA | U. SATA 3 (SAS 1 in SR1530HCLS/ SR1530HCLSR) |
| D. Back Panel I/O Ports | M. USB Header | V. SATA 4 (SAS 2 in SR1530HCLS/ SR1530HCLSR) |
| E. Main Power Connector | N. IDE Connector | W. SATA 5 (SAS 3 in SR1530HCLS/ SR1530HCLSR) |
| F. Auxiliary Power Signal Connector | O. PCI Fan | X. CMOS Battery |
| G. Processor Power Connector | P. SATA 0 | Y. SGPIO SAS |
| H. DIMM Sockets | Q. SATA 1 | |
| I. Processor 1 Socket | R. Front Control Panel Header | |

Figure 10. Server Board Connector and Component Locations

Configuration Jumpers

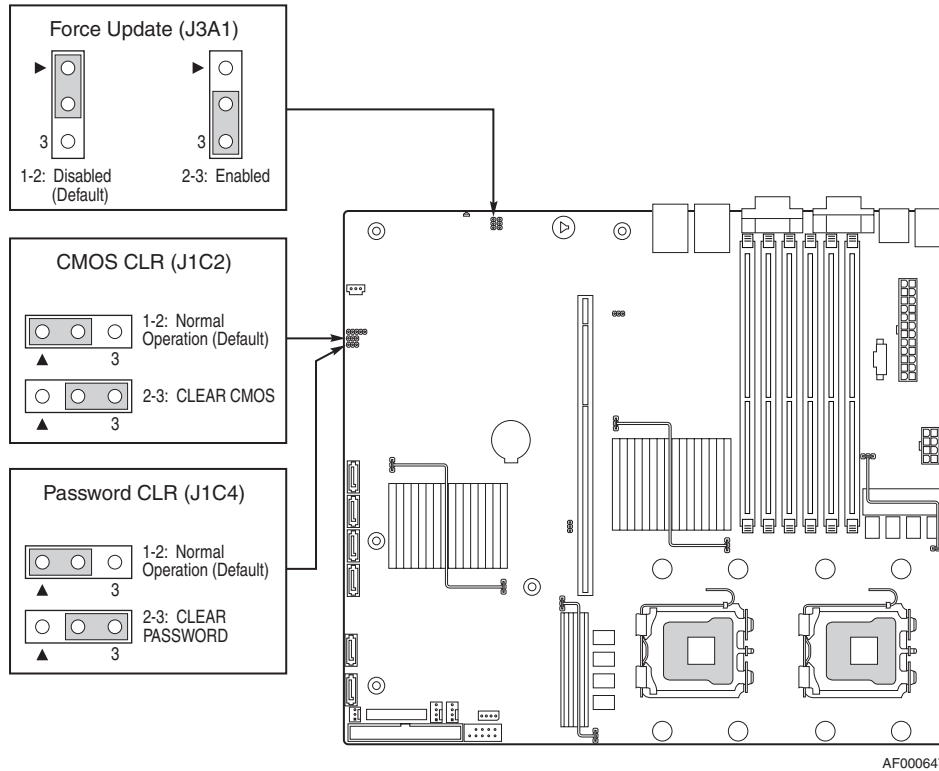

| Jumper Name | Pins | What Happens at System Reset |
|------------------|-------|--|
| CMOS Clear | 1 - 2 | Protect CMOS: These pins should be jumpered for normal operation |
| | 2 - 3 | Erase CMOS: If these pins are jumpered for five to ten seconds the CMOS settings will be cleared on the next server reset. These pins should not be jumpered for normal operation. |
| Password Clear | 1 - 2 | Protect Password: These pins should be jumpered for normal operation. |
| | 2 - 3 | Erase Password: If these pins are jumpered for five to ten seconds the password settings will be cleared on the next server reset. These pins should not be jumpered for normal operation. |
| BMC Force Update | 1 - 2 | Disable Force Update: These pins should be jumpered for normal operation. |
| | 2 - 3 | Enable Force Update: Jumpering these pins forces a BMC update. |

Figure 11. Configuration Jumpers

RAID Support

The Intel® Server System SR1530CL / SR1530HCL / SR1530HCLS and the Intel® Server System SR1530CLR / SR1530HCLR / SR1530HCLSR provide SATA support. The embedded SATA controller supports both 1.5 and 3.0 Gbps data transfer rates.

The BIOS Setup utility provides multiple drive configuration options on the Advanced | ATA Controller setup page, some of which affect the ability to configure RAID. The “Onboard SATA Controller” option is enabled by default. When this option is enabled, the “SATA Mode” option can be set to either Legacy or Enhanced. The Legacy and Enhanced modes affect the features and available ports as follows:

- Legacy does not provide RAID support.
- Enhanced is required for RAID configurations.

When the enhanced mode is selected, you can choose to enable or disable “AHCI Mode” or “Configure SATA as RAID”. Intel® Embedded Server RAID Technology II is enabled by the option, “Configure SATA as RAID.” The Intel® Embedded Server RAID Technology II feature provides RAID modes 0, 1, and 10.

Notes: For assistance in navigating through the F2 BIOS Setup utility, see the Intel® Server Board S5000VCL Technical Product Specification.

For information on setting up RAID, see the RAID Software Guide that is included on the Intel® Server Deployment Toolkit 2.0 CD.

Rack-Mounted Systems

The Intel® Server System SR1530CL / SR1530HCL / SR1530HCLS and the Intel® Server System SR1530CLR / SR1530HCLR / SR1530HCLSR can be mounted into a rack.

When installing the system into a rack, Intel recommends you install systems from the bottom of the rack to the top. In other words, install the first system in the rack into the bottom position of the rack, the second system in the second position from the bottom, and so on. Instructions for installing your chassis into a rack are included in the rail kit.

The order numbers are as follows:

- Fixed mount relay rack / cabinet mount kit that can be configured to mount the system into either a 2-post or 4-post cabinet: AXXBRACKETS
- Basic slide rail kit designed to mount the system into a standard, 19-inch by 30-inch EIA-310D-compatible cabinet: AXXBASICRAIL (included with system)
- High-end tool-less rail kit: AXXHERAIL

Hardware Requirements

To avoid integration difficulties and possible board damage, your system must meet the requirements outlined below. For a list of qualified components, see the links under “Server System References” on page ix.

Processor

Support for one or two Dual-Core Intel® Xeon® processors, or Quad-Core Intel® Xeon® processors (80-W versions only). For a complete list of supported processors, see <http://support.intel.com/support/motherboards/s5000vsl/sb/CS-023399.htm>.

Memory

The Intel® Server System SR1530CL / SR1530HCL / SR1530HCLS and the Intel® Server System SR1530CLR / SR1530HCLR / SR1530HCLSR provide six DIMM sockets across two channels, Channel A and Channel B. Channel A consists of DIMM sockets A1, A2, and A3. Channel B consists of DIMM sockets B1, B2, and B3. See the figure below to locate the DIMM sockets.

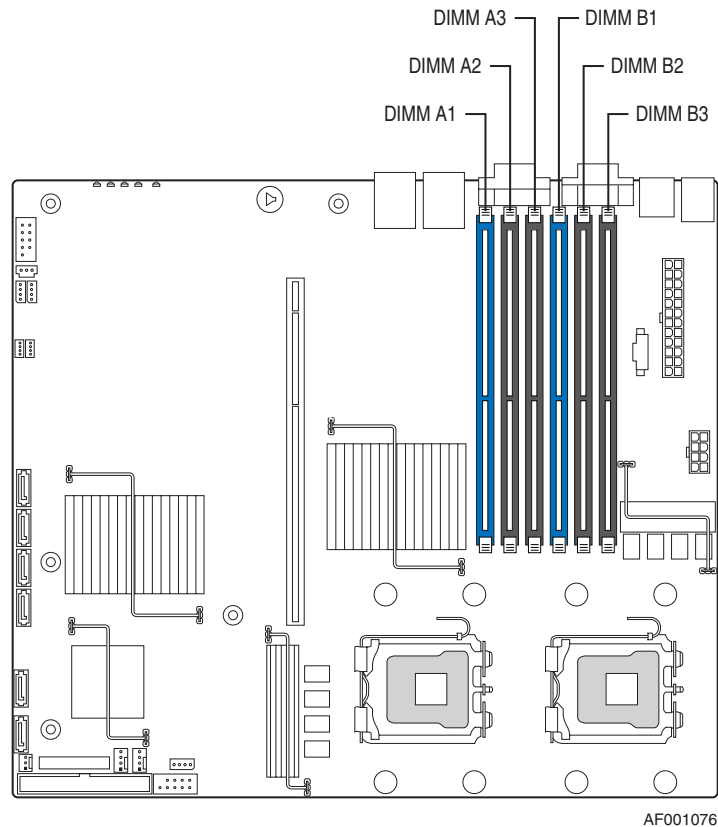

Figure 12. Identifying DIMM Sockets

A minimum of one 256-MB FBDIMM is required in DIMM socket A1 or B1. This uses single-channel interleave. However, for dual-channel interleave, providing optimum performance, a minimum of two FBDIMMs should be installed in DIMM sockets A1 and B1. Except for the option of installing a single DIMM in socket A1 or B1, DIMMs must be installed in pairs and populated as follows:

- DIMM A1 and DIMM B1: Populate these two sockets together first
- DIMM A2 and DIMM B2: Populate these sockets in addition to DIMM A1 and DIMM B1 if four DIMMs are to be used
- DIMM A3 and DIMM B3: Populate these sockets after DIMM A1, DIMM B1, DIMM A2, and DIMM B2 have been populated
- FBDIMMs must meet the following requirements:
 - Use only FBDIMM 667-MHz fully buffered, registered DIMM modules.
 - Use only FBDIMMs that comply with the JEDEC Revision 2.0 specifications.
 - Use only 240-pin DIMMs.

For a complete list of supported memory DIMMs, see the links under [“Server System References”](#) on page ix.

2 Server Utilities

Using the BIOS Setup Utility

This section describes the BIOS Setup Utility options, which is used to change server configuration defaults. You can run BIOS Setup with or without an operating system being present. See [“Server System References” on page ix](#) for a link to the Intel® 5000 Series Chipsets Server Board Family Datasheet where you will find details about specific BIOS setup screens.

Starting Setup

You can enter and start BIOS Setup under several conditions:

- When you turn on the server, after POST completes the memory test.
- When you have moved the CMOS jumper on the server board to the "Clear CMOS" position (enabled).

In the two conditions listed above, during the Power On Self Test (POST), you will see this prompt:

```
Press <F2> to enter SETUP
```

In a third condition, when CMOS/NVRAM has been corrupted, you will see other prompts but not the <F2> prompt:

```
Warning: CMOS checksum invalid  
Warning: CMOS time and date not set
```

In this condition, the BIOS will load default values for CMOS and attempt to boot.

If You Cannot Access Setup

If you are not able to access BIOS Setup, you might need to clear the CMOS memory. For instructions on clearing the CMOS, see [“Clearing the CMOS” on page 22](#).

Setup Menus

Each BIOS Setup menu page contains a number of features. Except for those features that are provided only to display automatically configured information, each feature is associated with a value field that contains user-selectable parameters. These parameters can be changed if the user has adequate security rights. If a value cannot be changed for any reason, the feature's value field is inaccessible.

“Setup Menu Key Use” describes the keyboard commands you can use in the BIOS Setup menus.

Table 3. Setup Menu Key Use

| Key to Press | Description |
|-----------------------|--|
| <F1> | Pressing the <F1> key on any menu invokes the general help window. |
| Left and right arrows | The left and right arrow keys are used to move between the major menu pages. The keys have no affect if a submenu or pick list is displayed. |
| Up arrow | Select Item up - The up arrow is used to select the previous value in a menu item's option list, or a value field pick list. Pressing the <Enter> key activates the selected item. |
| Down arrow | Select Item down - The down arrow is used to select the next value in a menu item's option list, or a value field pick list. Pressing the <Enter> key activates the selected item. |
| <F5> or <-> | Change Value - The minus key or the <F5> function key is used to change the value of the current item to the previous value. This key scrolls through the values in the associated pick list without displaying the full list. |
| <F6> or <+> | Change Value - The plus key or the <F6> function key is used to change the value of the current menu item to the next value. This key scrolls through the values in the associated pick list without displaying the full list. On 106-key Japanese keyboards, the plus key has a different scan code than the plus key on the other keyboard, but it has the same effect. |
| <Enter> | Execute Command - The <Enter> key is used to activate submenus when the selected feature is a submenu, or to display a pick list if a selected feature has a value field, or to select a sub-field for multi-valued features like time and date. If a pick list is displayed, the <Enter> key will undo the pick list, and allow another selection in the parent menu. |
| <Esc> | Exit - The <Esc> key provides a mechanism for backing out of any field. This key will undo the pressing of the <Enter> key. When the <Esc> key is pressed while editing any field or selecting features of a menu, the parent menu is re-entered. When the <Esc> key is pressed in any submenu, the parent menu is re-entered. When the <Esc> key is pressed in any major menu, the exit confirmation window is displayed and the user is asked whether changes can be discarded. |
| <F9> | Setup Defaults - Pressing <F9> causes the following to appear: <pre style="margin-left: 40px;"> Setup Confirmation Load default configuration now? [Yes] [No] </pre> If "Yes" is selected and the <Enter> key is pressed, all Setup fields are set to their default values. If "No" is selected and the <Enter> key is pressed, or if the <Esc> key is pressed, the user is returned to where they were before <F9> was pressed without affecting any existing field values. |

Table 3. Setup Menu Key Use

| Key to Press | Description |
|--------------|---|
| <F10> | <p>Save and Exit - Pressing the <F10> key causes the following message to appear:</p> <pre> Setup Confirmation Save Configuration changes and exit now? [Yes] [No]</pre> <p>If "Yes" is selected and the <Enter> key is pressed, all changes are saved and Setup is exited. If "No" is selected and the <Enter> key is pressed, or the <Esc> key is pressed, the user is returned to where they were before <F10> was pressed without affecting any existing values.</p> |

Upgrading the BIOS

The upgrade utility allows you to upgrade the BIOS in flash memory. The code and data in the upgrade file include the following:

- On-board system BIOS, including the recovery code, BIOS Setup Utility, and strings.
- On-board video BIOS, and other option ROMs for devices embedded on the server board.
- OEM binary area
- Microcode
- A way to change the BIOS language

Preparing for the Upgrade

The steps below explain how to prepare to upgrade the BIOS, including how to record the current BIOS settings and how to obtain the upgrade utility.

Note: *In the unlikely event that a BIOS error occurs during the BIOS update process, a recovery process may need to be followed to return the system to service. See “[Server System References](#)” on page ix for a link to necessary software and instructions.*

Recording the Current BIOS Settings

1. Boot the computer and press <F2> when you see the message:
Press <F2> Key if you want to run SETUP
2. Write down the current settings in the BIOS Setup program.

Note: *Do not skip step 2. You will need these settings to configure your server at the end of the procedure.*

Obtaining the Upgrade

Download the BIOS image file to a temporary folder on your hard drive. See [“Server System References”](#) on page ix for a link to the update software.

Note: *Review the instructions and release notes that are provided in the readme file distributed with the BIOS image file before attempting a BIOS upgrade. The release notes contain critical information regarding jumper settings, specific fixes, or other information to complete the upgrade.*

Upgrading the BIOS

Follow the instructions in the readme file that came with the BIOS upgrade. When the update completes, remove the bootable media from which you performed the upgrade.

Caution: *Do not power down the system during the BIOS update process! The system will reset automatically when the BIOS update process is completed.*

Note: *You may encounter a CMOS Checksum error or other problem after reboot. If this happens, shut down the system and boot it again. CMOS checksum errors require that you enter Setup, check your settings, save your settings, and exit Setup.*

Clearing the Password

If the user or administrator password(s) is lost or forgotten, moving the password clear jumper into the "clear" position clears both passwords. The password clear jumper must be restored to its original position before a new password(s) can be set.

1. Power down the system and disconnect the AC power.
2. Open the server chassis.
3. Move the jumper from the normal operation position, Password Clear Protect, covering pins 1 and 2 to the Password Clear Erase position, covering pins 2 and 3. See [Figure 13](#).

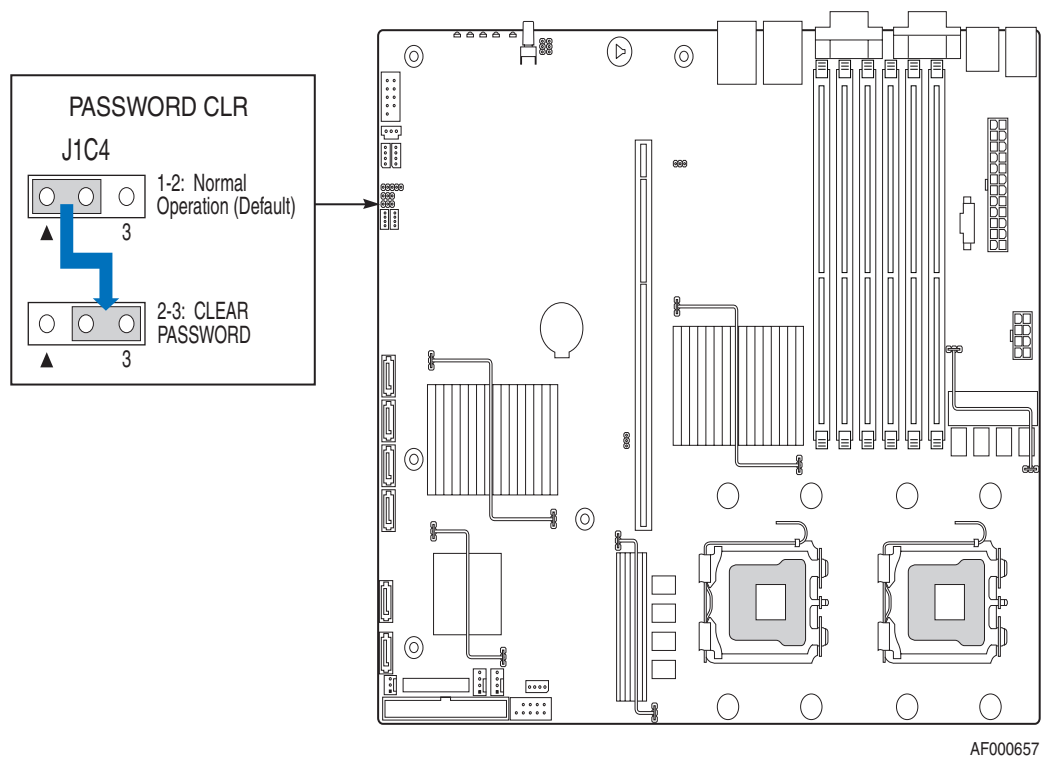

Figure 13. Clear Password Jumper

4. Reconnect the AC power.
5. Power up the system.
6. Power down the system and disconnect the AC power.
7. Return the Password Clear jumper to the Password Clear Protect position, covering pins 1 and 2.
8. Close the server chassis.
9. Reconnect the AC power and power up the server.

Clearing the CMOS

If you are not able to access the BIOS setup screens, the CMOS Clear jumper will need to be used to reset the configuration RAM.

1. Power down the system and disconnect the AC power.
2. Open the server.
3. Move the jumper from the Normal Operation position, covering pins 1 and 2 to the Clear CMOS position, covering pins 2 and 3.

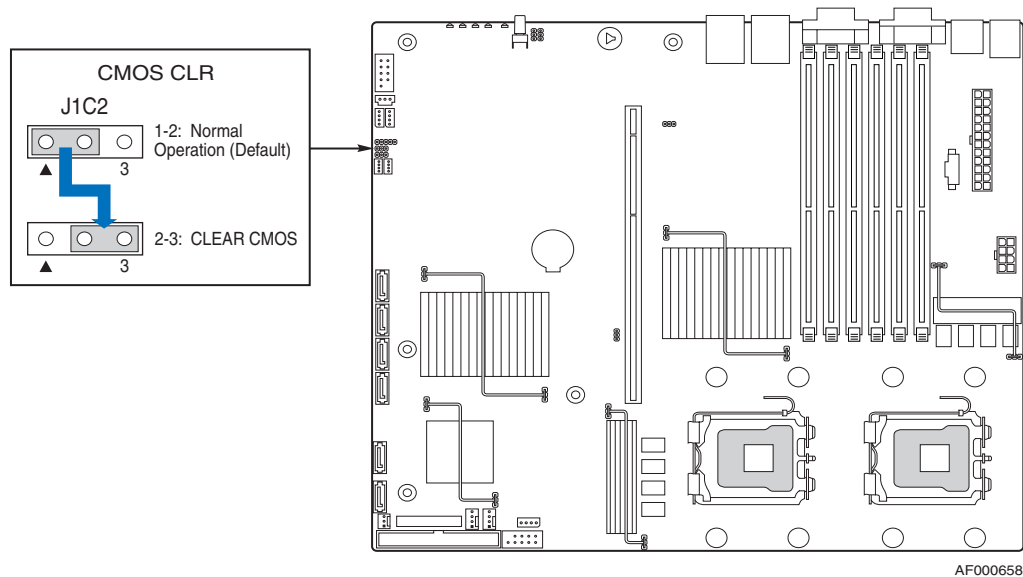

Figure 14. Clear CMOS Jumper

4. Reconnect the AC power
5. Power up the system.
6. When the system begins beeping, power it down and disconnect the AC power.
7. Return the jumper to the Normal Operation location, covering pins 1 and 2.
8. Close the server chassis.
9. Reconnect the AC power and power up the system.

Forcing a BMC Update

1. Power down the system and disconnect the AC power.
2. Open the server.
3. Move the jumper from the Disabled position, covering pins 1 and 2 to the Enabled position, covering pins 2 and 3.

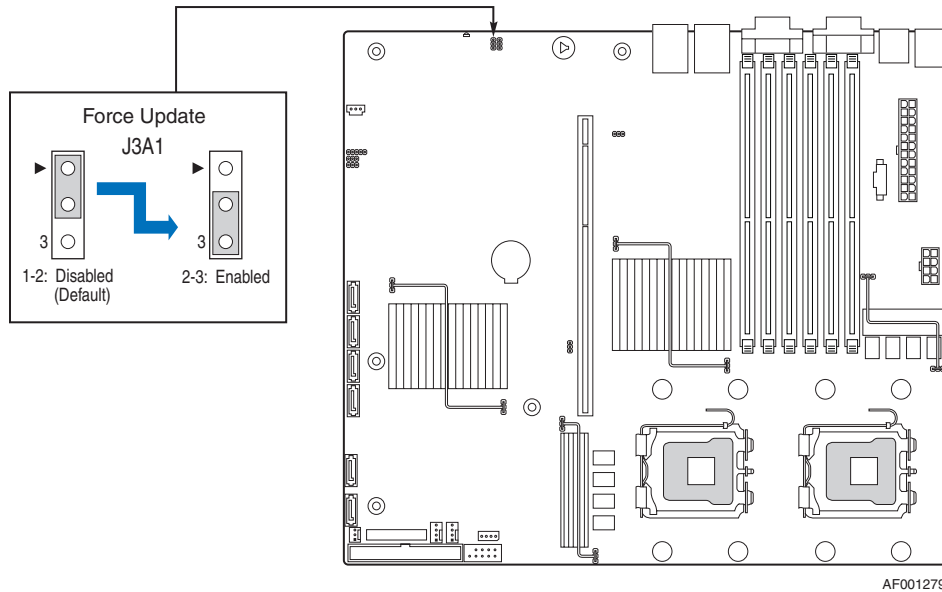

Figure 15. BMC Force Update Jumper

4. Reconnect the AC power
5. Power up the system.
6. When the system begins beeping, power it down and disconnect the AC power.
7. Return the jumper to the Disabled location, covering pins 1 and 2.
8. Close the server chassis.
9. Reconnect the AC power and power up the system.

3 Hardware Installations and Upgrades

Caution: No components in this server system are hot-swappable. Before removing or installing any component in this server system, you must first take the server out of service, turn off all peripheral devices connected to the system, turn off the system by pressing the power button, and unplug the AC power cord from the system or wall outlet.

Note: Some components in the Intel® Server System SR1530HCL / SR1530HCLS and Intel® Server System SR1530HCLR / SR1530HCLSR are hot-swappable and, where applicable, will be noted as such in the instructions.

Note: Most of the illustrations in this chapter show the Intel® Server System SR1530CL / SR1530CLR with an optional optical drive installed. The instructions for removing and installing components are the same for the Intel® Server System SR1530HCL / SR1530HCLS and the ntel® Server System SR1530HCLR / SR1530HCLSR unless otherwise noted. When instructions differ, separate illustrations will be shown for the Intel® Server System SR1530HCL / SR1530HCLS and the ntel® Server System SR1530HCLR / SR1530HCLSR.

Before You Begin

Before working with your server product, pay close attention to the “[Safety Information](#)” on page iii.

Tools and Supplies Needed

- Phillips* (cross head) screwdriver (#1 bit and #2 bit)
- Needle nosed pliers
- Antistatic wrist strap and conductive foam pad (recommended)

System References

All references to left, right, front, top, and bottom assume the reader is facing the front of the server system as it would be positioned for normal operation.

Removing and Installing the Front Bezel

The front bezel is available as an optional accessory for the Intel® Server System SR1530CL / SR1530HCL / SR1530HCLS and the Intel® Server System SR1530CLR / SR1530HCLR / SR1530HCLSR. Note the orientation in the following figures and make sure you position your bezel as shown.

Removing the Front Bezel

Use the steps below if your system includes a front bezel.

1. Unlock the bezel.
2. Disconnect any cables attached to the control panel.
3. Pull the bezel from the server system.

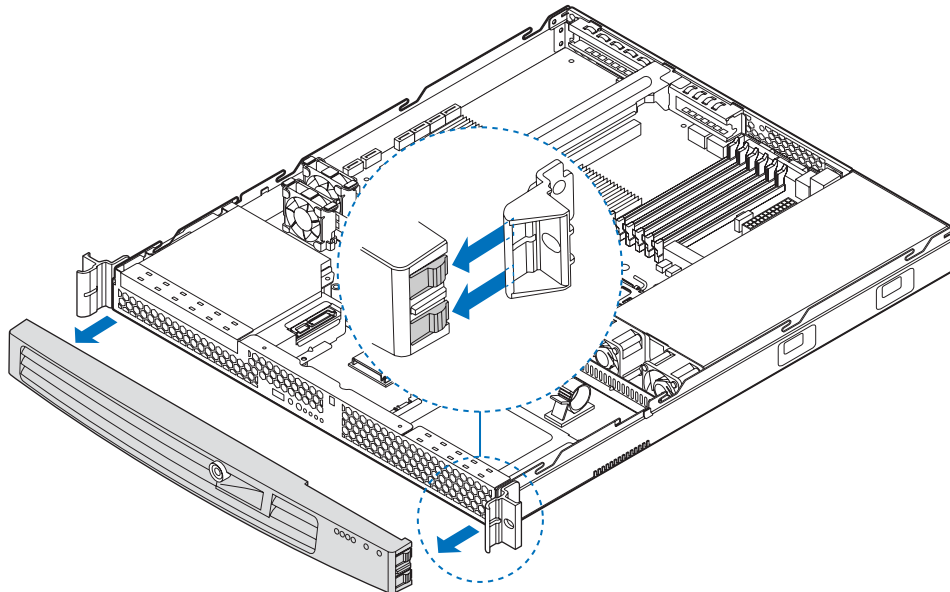

AF001057

Figure 16. Removing the Front Bezel (SR1530CL/SR1530CLR)

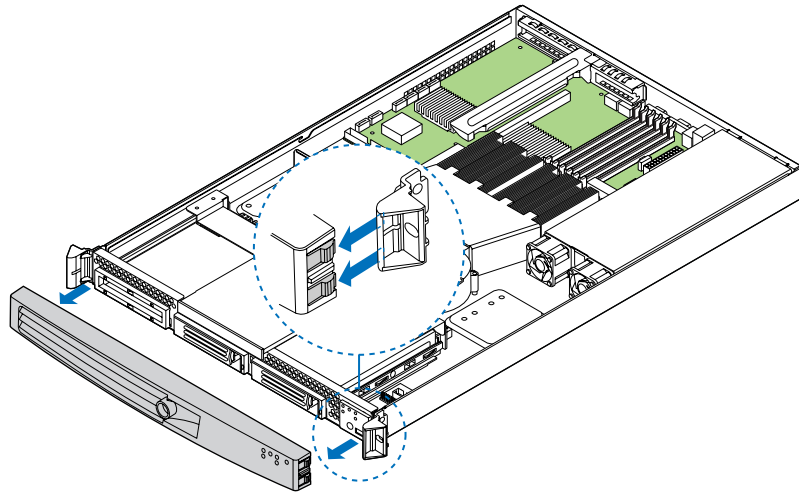

AF001613

Figure 17. Removing the Front Bezel (SR1530HCL/SR1530HCLS and SR1530HCLR/SR1530HCLSR)

Installing the Front Bezel

The front bezel is optional.

1. At each end of the bezel, line up the center notch on the bezel with the center guide on the rack handles.
2. Push the bezel onto the front of the server system until it clicks into place.
3. Lock the bezel.

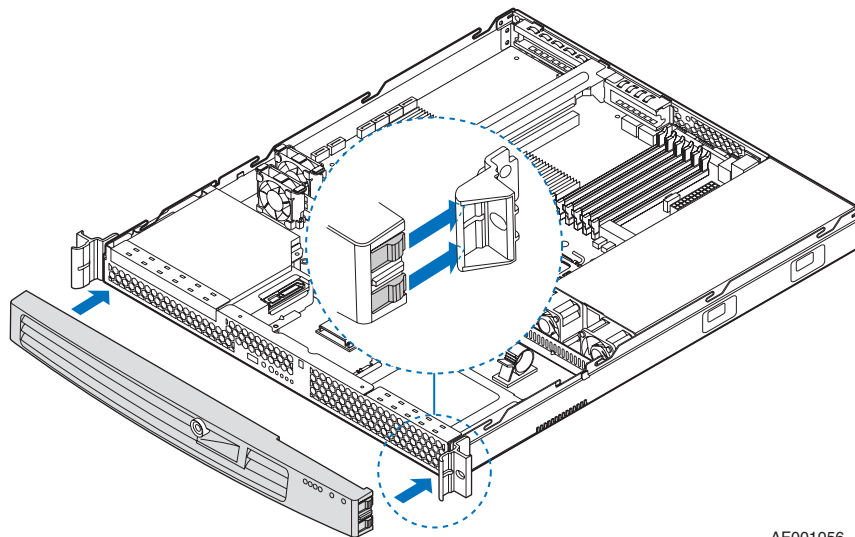

AF001056

Figure 18. Installing the Front Bezel (SR1530CL/SR1530CLR)

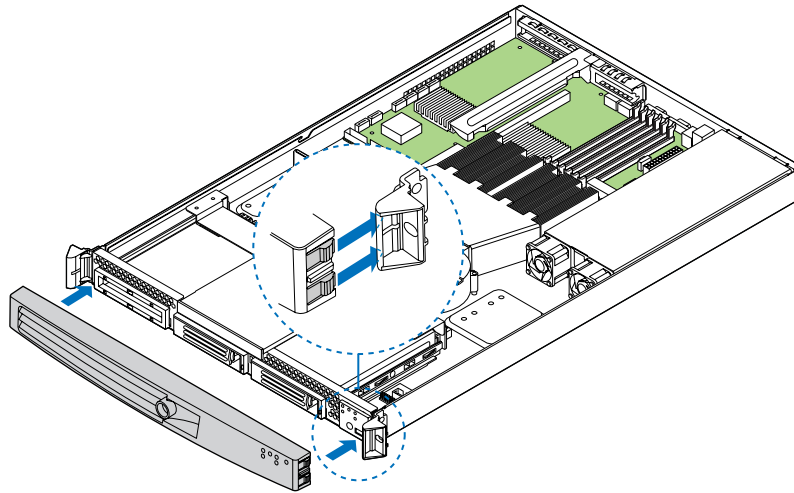

AF001614

Figure 19. Installing the Front Bezel (SR1530HCL/SR1530HCLS and SR1530HCLR/SR1530HCLSR)

Removing and Installing the Server Cover

Removing the Server System Cover

The server system must be operated with the server system cover in place to ensure proper cooling. You will need to remove the cover to add or replace components inside of the server.

None of the internal components are hot-swappable. Before removing the server system cover, power down the server and unplug all peripheral devices and the AC power cable.

Note: *A nonskid surface or a stop behind the server system may be needed to prevent the server system from sliding on your work surface.*

1. Observe the safety and ESD precautions at the beginning of this book. See [“Safety Information” on page iii](#).
2. Turn off all peripheral devices connected to the server. Turn off the server.
3. Disconnect the AC power cord.
4. (SR1530CL/SR1530CLR) Remove the two screws at the front of the chassis (see letter “A” in the following figure). Loosen the screw at the rear of the chassis (see letter “B”). Push rearward on the blue grip point at the front of the server. Slide the cover back until it stops and then lift the cover upward to remove it.. See letter “C”.

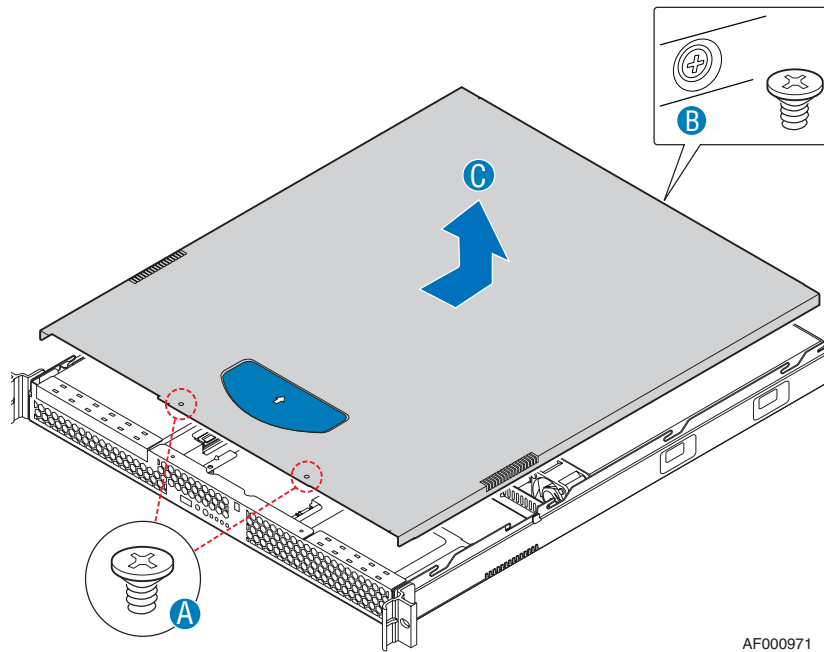

AF000971

Figure 20. Removing the Server System Cover (SR1530CL/SR1530CLR)

5. (SR1530HCL/SR1530HCLS and SR1530HCLR/SR1530HCLSR) Remove the four screws at the front of the chassis (see letter “A” in the following figure). Push rearward on the blue grip point at the front of the server. Slide the cover back until it stops and then lift cover upward to remove it (see letter “B”).

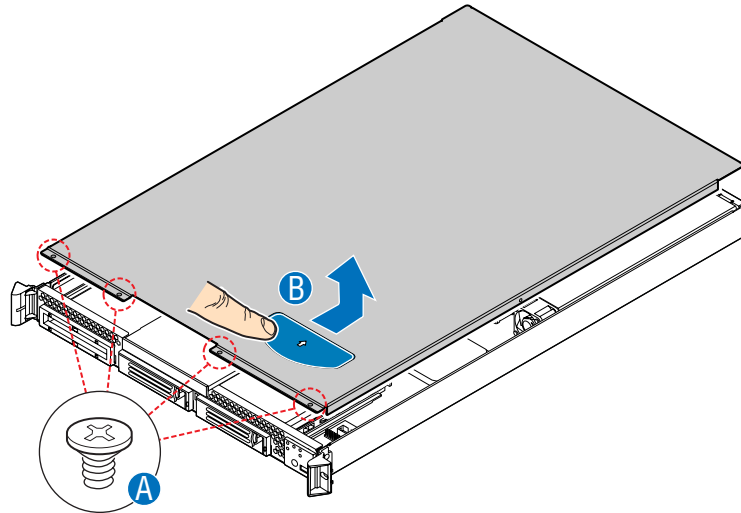

AF001615

Figure 21. Removing the Server System Cover (SR1530HCL/SR1530HCLS and SR1530HCLR/SR1530HCLSR)

Installing the Server System Cover

1. Observe the safety and ESD precautions at the beginning of this book. See “[Safety Information](#)” on page iii.
2. (SR1530CL/SR1530CLR) Place the cover over the server system so that the side edges of the cover sit just inside the server system sidewalls. Slide the cover forward (see letter “A” in the following figure). Tighten the screw at the rear of the server (see letter “B”). Install the two screws at the front of the server (see letter “C”).

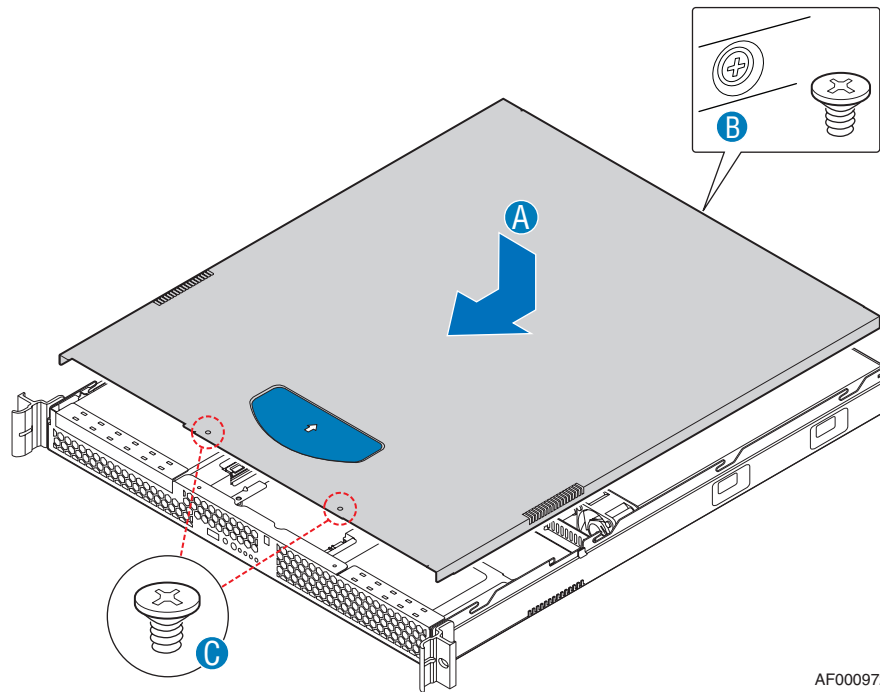

AF000972

Figure 22. Installing the Server System Cover (SR1530CL/SR1530CLR)

3. (SR1530HCL/SR1530HCLS and SR1530HCLR/SR1530HCLSR) Place the cover over the server system so that the side edges of the cover sit just inside the server system sidewalls. Slide the cover forward (see letter “A” in the following figure). Install the four screws at the front of the server (see letter “B”).

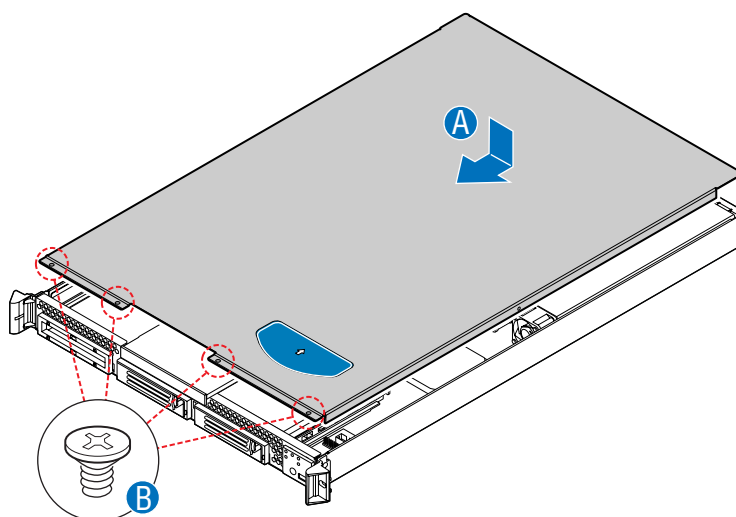

AF001616

Figure 23. Installing the Server System Cover (SR1530HCL/SR1530HCLS and SR1530HCLR/SR1530HCLSR)

4. Reconnect all peripheral devices and the AC power cord.

Removing and Installing the Processor Air Duct

Always operate your server system with the processor air duct in place. The air duct is required for proper airflow within the server system.

Removing the Processor Air Duct

1. Observe the safety and ESD precautions at the beginning of this book. See “[Safety Information](#)” on page iii.
2. Power down the server and unplug all peripheral devices and the AC power cable.
3. Remove the server system cover. For instructions, see “[Removing the Server System Cover](#)” on page 28.
4. Lift the processor air duct from its location behind the two system blower fans. See [Figure 24](#) for the Intel® Server System SR1530CL / SR1530CLR. See [Figure 25](#) for the Intel® Server System SR1530HCL / SR1530HCLS and the Intel® Server System SR1530HCLR / SR1530HCLSR.

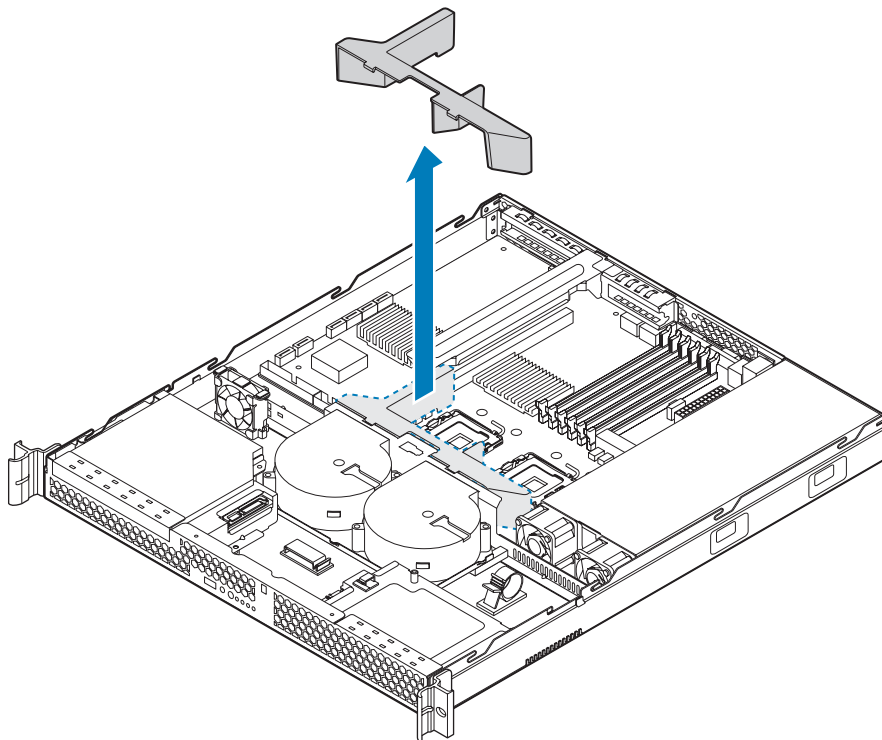

AF000973

Figure 24. Removing the Processor Air Duct (SR1530CL/SR1530CLR)

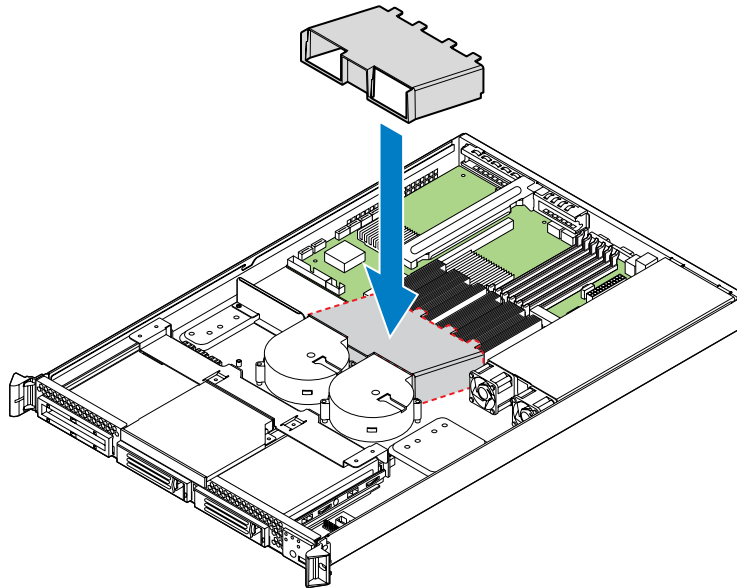

AF001618

Figure 25. Removing the Processor Air Duct (SR1530HCL/SR1530HCLS and SR1530HCLR/SR1530HCLSR)

Installing the Processor Air Duct

1. Observe the safety and ESD precautions at the beginning of this book. See [“Safety Information”](#) on page iii.
2. Power down the server and unplug all peripheral devices and the AC power cable.
3. Remove the server system cover. For instructions, see [“Removing the Server System Cover”](#) on page 28.
4. Lower the air duct into place, insert the two hooks at the front of the processor air duct into the corresponding slots on the bracket behind the two system blower fans. Use caution not to pinch or disengage cables that may be near or under the air duct. See [Figure 26](#) for the Intel® Server System SR1530CL / SR1530CLR. See [Figure 27](#) for the Intel® Server System SR1530HCL / SR1530HCLS and the Intel® Server System SR1530HCLR / SR1530HCLSR.

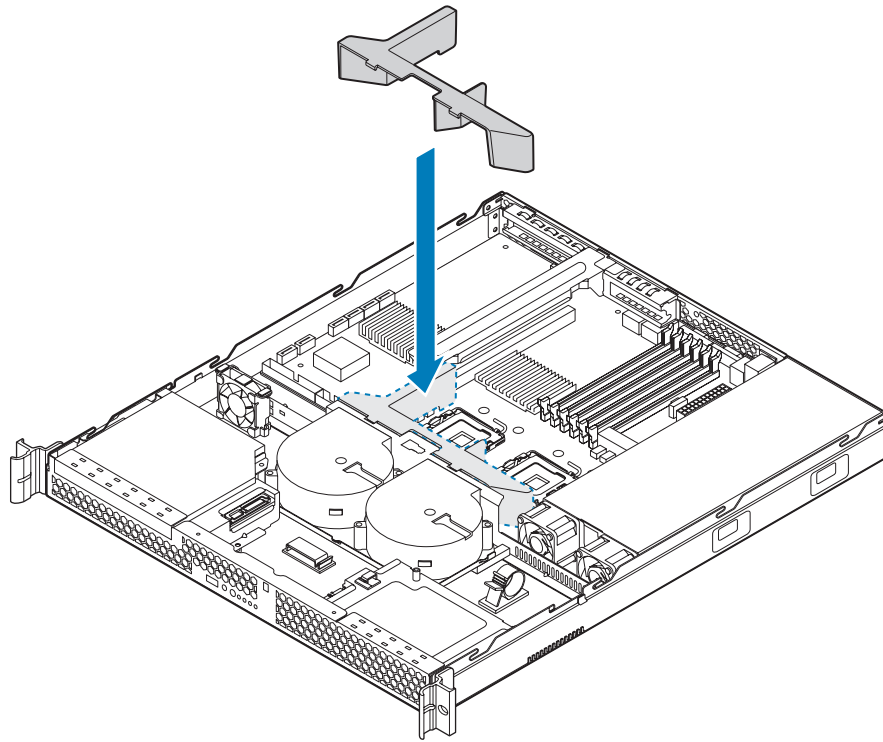

AF000974

Figure 26. Installing the Processor Air Duct (SR1530CL/SR1530CLR)

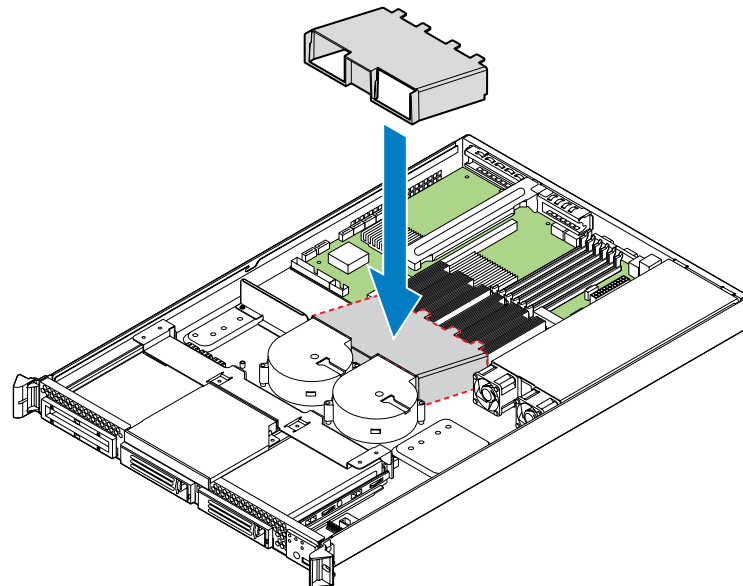

AF001618

Figure 27. Installing the Processor Air Duct (SR1530HCL/SR1530HCLS and SR1530HCLR/SR1530HCLSR)

5. Install the server system cover. For instructions, see [“Installing the Server System Cover”](#) on page 30.

Installing and Removing Memory

Caution: *The memory is NOT hot swappable. Before removing or replacing any memory DIMM, you must first take the server out of service, turn off all peripheral devices connected to the system, turn off the system by pressing the power button, and unplug the AC power cord from the system or wall outlet.*

The silkscreen on the board for the DIMMs displays DIMM A1, DIMM A2, DIMM A3, DIMM B1, DIMM B2, and DIMM B3 starting from the center of the board. See [“Memory”](#) on page 15 for a discussion of the memory requirements and options. See [“Server System References”](#) on page ix for a link to the list of tested DIMMs.

Installing DIMMs

To install DIMMs, follow these steps:

1. Observe the safety and ESD precautions at the beginning of this book. See [“Safety Information”](#) on page iii.
2. Power down the server and unplug all peripheral devices and the AC power cable.
3. Remove the server system cover. For instructions, see [“Removing the Server System Cover”](#) on page 28.
4. Locate the DIMM sockets. See [Figure 28](#).

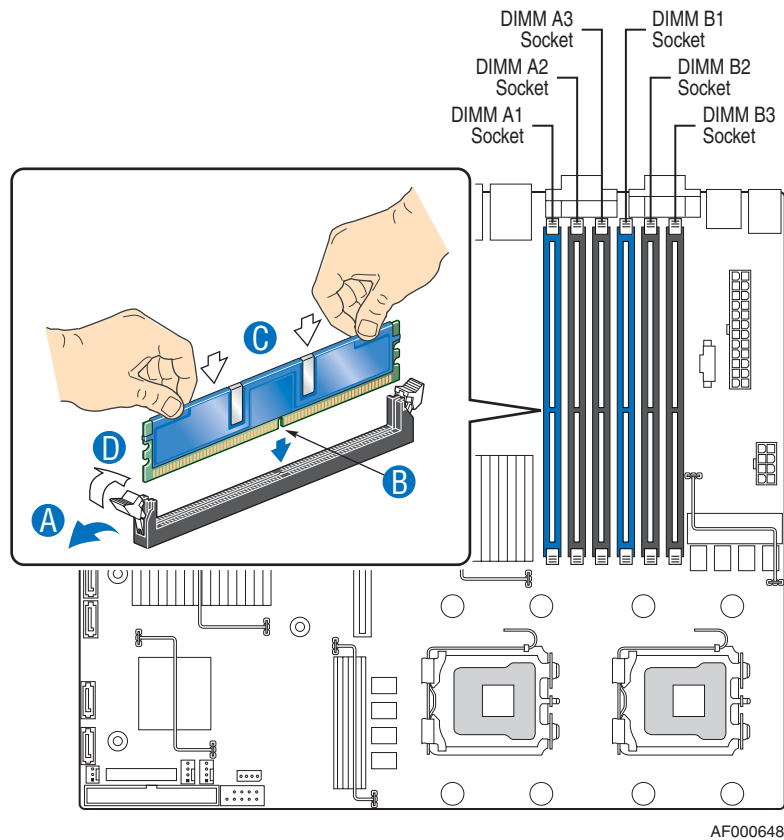

AF000648

Figure 28. Installing the Memory

5. Make sure the clips at both ends of the DIMM socket(s) are pushed outward to the open position. See letter “A” in [Figure 28](#).
6. Holding the DIMM by the edges, remove it from its anti-static package.
7. Position the DIMM above the socket. Align the notch on the bottom edge of the DIMM with the key in the DIMM socket. See letter “B” in the figure.
8. Insert the bottom edge of the DIMM into the socket. See letter “C” in the figure.
9. When the DIMM is correctly positioned, push down on the top edge of the DIMM until the retaining clips snap into place.
10. Make sure the clips are firmly in place. See letter “D” in the figure.
11. Install the server system cover. For instructions, see [“Installing the Server System Cover” on page 30](#).

Removing DIMMs

To remove a DIMM, follow these steps:

1. Observe the safety and ESD precautions at the beginning of this book. See [“Safety Information” on page iii](#).
2. Power down the server and unplug all peripheral devices and the AC power cable.
3. Remove the server system cover. For instructions, see [“Removing the Server System Cover” on page 28](#).
4. Locate the DIMM sockets. See [Figure 28](#).
5. Gently spread the retaining clips at each end of the socket. The DIMM lifts from the socket.
6. Holding the DIMM by the edges, lift it from the socket, and store it in an anti-static package.
7. Install the server system cover. For instructions, see [“Installing the Server System Cover” on page 30](#).

Installing or Replacing the Processor

Caution: *Processor must be appropriate: You may damage the server board if you install a processor that is inappropriate for your server. See [“Server System References” on page ix](#) for a link to the list of compatible processor(s).*

Caution: *ESD and handling processors: Reduce the risk of electrostatic discharge (ESD) damage to the processor by doing the following: (1) Touch the metal chassis before touching the processor or server board. Keep part of your body in contact with the metal chassis to dissipate the static charge while handling the processor. (2) Avoid moving around unnecessarily.*

Installing the Processor

To install a processor, follow these instructions:

1. Observe the safety and ESD precautions at the beginning of this book. See [“Safety Information” on page iii](#).
2. Power down the server and unplug all peripheral devices and the AC power cable.
3. Remove the server system cover. For instructions, see [“Removing the Server System Cover” on page 28](#).
4. Locate the processor socket and raise the socket handle completely.

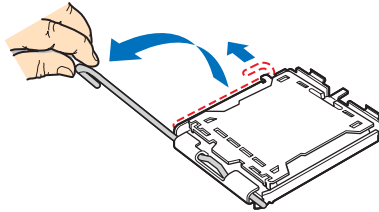

AF000650

Figure 29. Lifting the Processor Socket Handle

- 5. Push the rear tab with your finger to slightly lift the front of the load plate. Raise the load plate completely. Raise the CPU load plate.

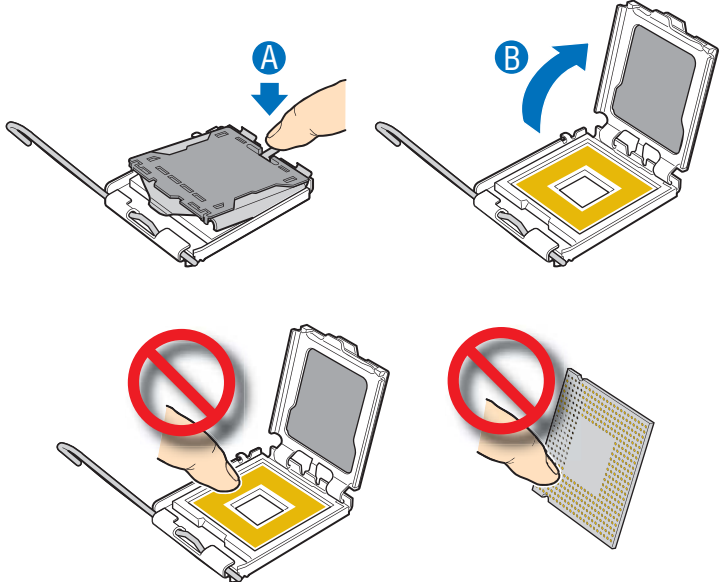

AF000651

Figure 30. Opening the Load Plate

Caution: Do not touch the socket pins; they are very sensitive and easily damaged.

6. Remove the processor from the packaging box and remove the protective shipping cover.

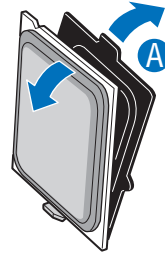

AF000653

Figure 31. Removing the Shipping Cover

7. Orient the processor with the socket so the processor cutouts match the socket notches (see letter “A” in the following figure). Set the processor into place as shown in letter B.

Note: Make sure the alignment triangle mark and the alignment triangle cutout align correctly.

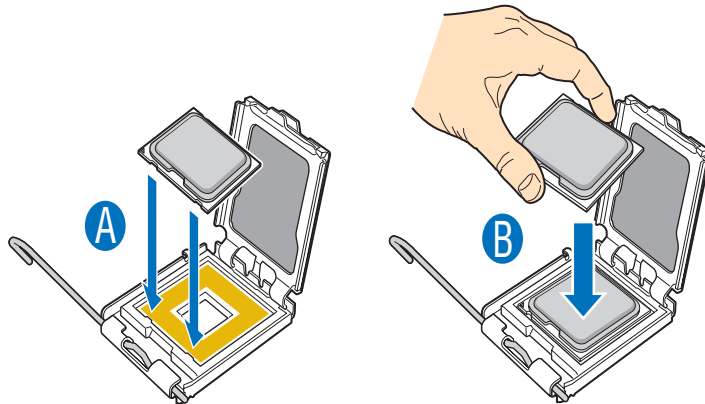

AF000654

Figure 32. Installing the Processor

8. Remove the protective socket cover.

Note: Retain the protective socket cover for use when removing a processor that will not be replaced.

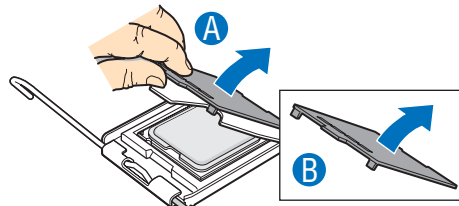

AF000652

Figure 33. Removing the Protective Socket Cover

9. Lower the CPU load plate.
10. Lower the socket lever.
11. Install the heat sink. For instructions, see [“Installing the Heat Sink” on page 40](#).

Installing the Heat Sink

Install your processor before installing the heat sink. For instructions, see [“Installing the Processor” on page 37](#).

Caution: *The heat sink has Thermal Interface Material (TIM) located on the bottom of it. Use caution when you unpack the heat sink so you do not damage the TIM.*

1. Orient the heat sink over the processor as shown in [Figure 34](#). The fins must be positioned as shown to provide correct airflow through the system.
2. Set the heat sink over the processor, lining up the four captive screws with the four posts surrounding the processor. Install the heat sinks with the corner tabs pointed away from the power supply to avoid pinching any cables.
3. Loosely screw in the captive screws on the heat sink corners in a diagonal manner as shown by the four circled numbers in the figure below. Do not fully tighten one screw before tightening another.
4. Gradually and equally tighten each captive screw in the same order until each screw is firmly tightened.

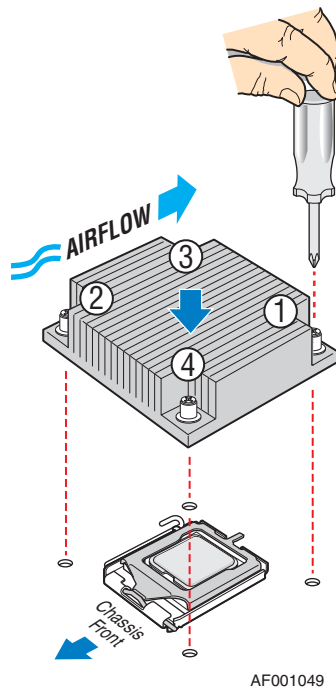

Figure 34. Installing the Heat Sink

5. Reinstall and reconnect any parts you removed or disconnected to reach the processor sockets.
6. Install the server system cover. For instructions, see “[Installing the Server System Cover](#)” on page 30.

Removing the Heat Sink and Processor

1. Observe the safety and ESD precautions at the beginning of this book. See “[Safety Information](#)” on page iii.
2. Power down the server and unplug all peripheral devices and the AC power cable.
3. Remove the server system cover. For instructions, see “[Removing the Server System Cover](#)” on page 28.
4. Loosen the four captive screws on the corners of the heat sink.
5. Twist the heat sink slightly to break the seal between the heat sink and the processor.
6. Lift the heat sink from the processor. If it does not pull up easily, twist the heat sink again. Do not force the heat sink from the processor. Doing so could damage the processor.
7. Lift the processor lever.
8. Raise the CPU load plate.
9. Remove the processor.

10. If installing a replacement processor, see [“Installing the Processor”](#) on page 37. Otherwise, install the protective socket cover over the empty processor socket and then reinstall the chassis cover.

Installing and Removing a Hard Drive (SR1530CL/SR1530CLR)

Caution: *The hard drives are NOT hot-swappable. Before removing or replacing a hard drive, you must first take the server out of service, turn off all peripheral devices connected to the system, turn off the system by pressing the power button, and unplug the AC power cord from the system or wall outlet.*

Up to two SATA drives can be installed. The HDD0 drive bay is at the left side of the chassis, underneath the optional CD-ROM drive. The HDD1 drive bay is at the right side of the chassis. The drives do not need to be installed in order; HDD1 can be installed before HDD0.

Note: *The server system does not support all hard drives. See [“Server System References”](#) on page ix for an Internet link to a list of supported hardware.*

Installing a Hard Disk Drive (SR1530CL/SR1530CLR)

Note: *If you are replacing a hard disk drive, see [“Removing a Hard Disk Drive \(SR1530CL/SR1530CLR\)”](#) on page 46 for instructions first. Return to these steps when directed.*

1. Observe the safety and ESD precautions at the beginning of this book. See [“Safety Information”](#) on page iii.
2. Power down the server. Unplug all peripheral devices and the AC power cable.
3. Remove the server system cover. For instructions, see [“Removing the Server System Cover”](#) on page 28.
4. Locate the drive position you want to use.

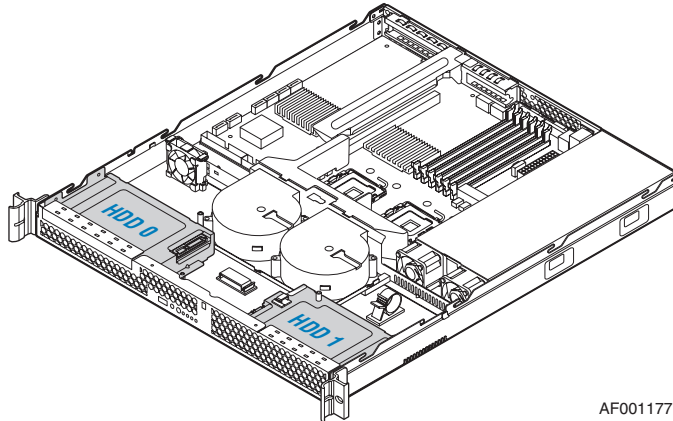

AF001177

Figure 35. Locating Drive Positions (SR1530CL/SR1530CLR)

5. HDD1 location only: Slide the power cables from the cable clip that is located on the top of the hard drive carrier.
6. Remove the screw that secures the hard drive bracket to the chassis (see letter "A" in the following figure). Save this screw. You will use it later to reinstall the drive assembly. Lift the drive carrier from the chassis (see letter "B").

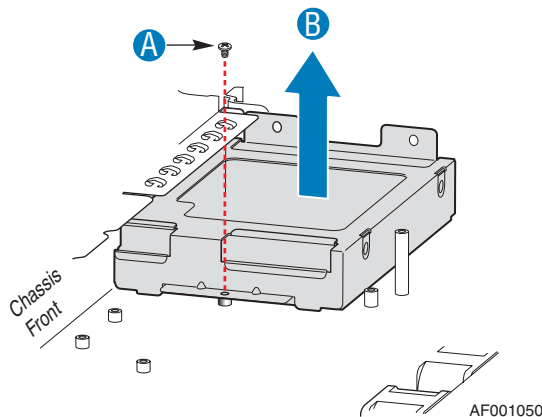
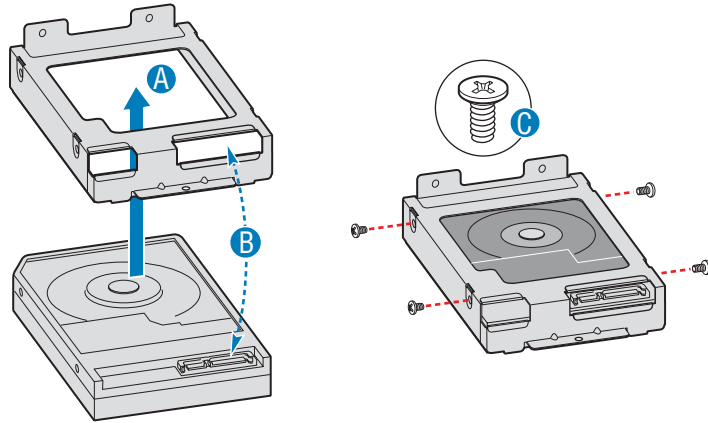

Figure 36. Removing Drive Carrier from Server System (SR1530CL/SR1530CLR)

7. Position the drive with the drive connectors facing up, as shown in the following figure. Set the drive carrier over the drive (see letter "A"). The data and power connectors must be positioned so they are accessible through the cut-out, as shown by letter "B". Use the four screws provided to attach the drive to the carrier (see letter "C").



AF000668

Figure 37. Installing Drive into Drive Carrier (SR1530CL/SR1530CLR)

8. Set the drive assembly into place in the chassis. See letter “A” in the following figure.
9. Attach the drive assembly to the chassis with the screw that you removed previously (see letter “B”).

Note: *The assembly that contains the optical drive bracket must be installed at the left side of the system.*

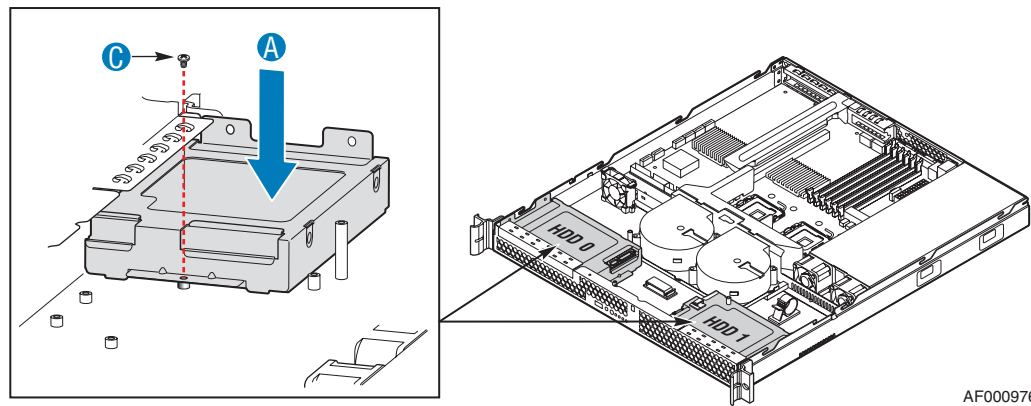

AF000976

Figure 38. Install Drive Assembly into Server System (SR1530CL/SR1530CLR)

10. HDD1 only: Route the power cable into the cable clip on the top of the hard drive bracket.
11. Connect the data cables to the drive(s).
 - If a drive is installed in the HDD0 carrier, connect the HDD0 data cable to the SATA 0 connector on the server board. See letter “A” in [Figure 39](#).
 - If a drive is installed in the HDD1 carrier, connect the HDD1 data cable to the SATA 1 connector on the server board. See letter “B” in [Figure 39](#).

Note: *The data cables are factory routed underneath the fan module. Use caution to make sure you connect the cables between the server board and the hard drives. The cables are labeled at each end.*

12. Connect the power cables to the drive(s):
 - If a drive is installed in the HDD1 carrier, attach the connector on the daisy chain power cable that is closest to the power supply to the HDD1 connector. See letter “D” in [Figure 39](#).
 - If a drive is installed in the HDD0 carrier, attach the middle connector on the daisy chain power cable to the HDD0 power connector. See letter “C” in [Figure 39](#).

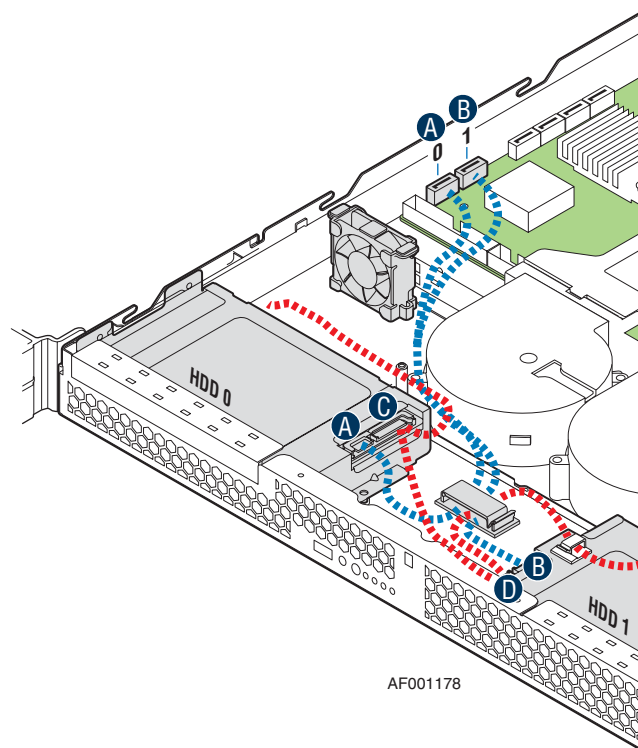

Figure 39. Connecting Hard Drive Power and Data Cables (SR1530CL/ SR1530CLR)

13. Install the server system cover. For instructions, see [“Installing the Server System Cover” on page 30](#).

Removing a Hard Disk Drive (SR1530CL/SR1530CLR)

1. Observe the safety and ESD precautions at the beginning of this book. See [“Safety Information” on page iii](#).
2. Power down the server and unplug all peripheral devices and the AC power cable.
3. Remove the server system cover. For instructions, see [“Removing the Server System Cover” on page 28](#).
4. Disconnect the power and data cables from the drive.
5. HDD1 location only: Slide the power cable from the cable clip that is located on the top of the hard drive carrier.
6. Remove the screw that holds the hard drive bracket to the chassis (see letter "A" in the following figure). Save this screw. You will use it later to reinstall the drive assembly. Lift the drive carrier from the chassis (see letter “B”).

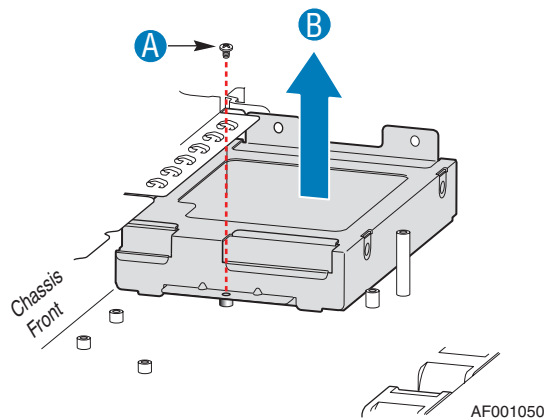

Figure 40. Removing Drive Carrier from the Server System (SR1530CL/SR1530CLR)

7. Remove the four screws that attach the hard drive to the drive carrier. Lift the drive from the carrier. Store the drive in an anti-static bag.
8. If you are installing a new drive, skip the rest of these steps and instead see [“Installing a Hard Disk Drive \(SR1530CL/SR1530CLR\)” on page 42](#), beginning with step 7.
9. Insert the screws that held the drive in the carrier into the screw locations on the carrier for future use.

- Set the drive assembly into place in the chassis (see letter “A” in the following figure). Attach the drive assembly to the chassis with the screw that you removed previously (see letter “B”).

Note: The assembly that contains the optical drive bracket must be installed at the left side of the system.

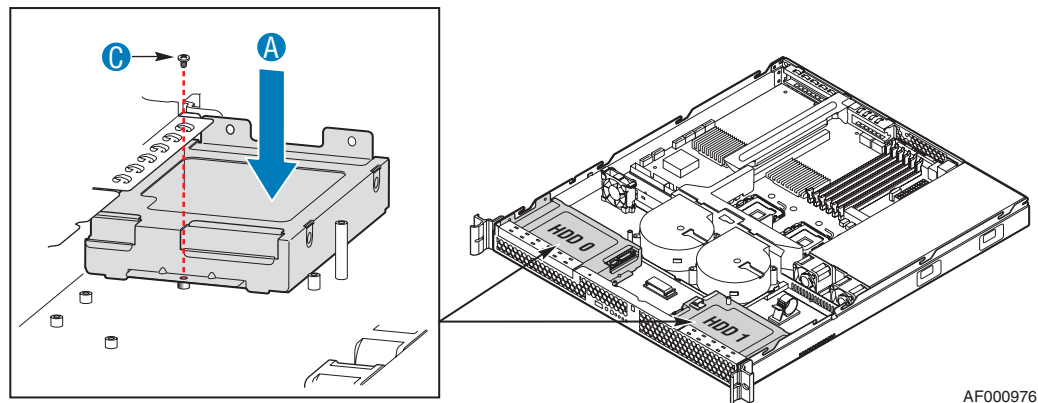

Figure 41. Install Drive Assembly into the Server System (SR1530CL/SR1530CLR)

- Install the server system cover. For instructions, see “Installing the Server System Cover” on page 30.

Installing and Removing a Hot-Swap SAS/SATA Drive (SR1530HCL/SR1530HCLS and SR1530HCLR/SR1530HCLSR)

Up to three hot-swappable SAS/SATA drives can be installed. The HDD0 drive bay is at the left side of the chassis. The HDD1 drive bay is in the middle of the chassis, underneath the optional optical drive. The HDD2 drive bay is at the right side of the chassis. The drives do not need to be installed in order; HDD1 can be installed before HDD0.

Caution: If you install less than three drives or devices, the empty drive bays must be occupied by carriers with baffles to maintain proper system cooling.

Note: The server system does not support all hard drives. See “Server System References” on page ix for an Internet link to a list of supported hardware.

Installing a Hot-Swap SAS/SATA Drive (SR1530HCL/ SR1530HCLS and SR1530HCLR/SR1530HCLSR)

1. Remove the front bezel if it is installed. For instructions, see “[Removing the Front Bezel](#)” on page 26.
2. Locate the drive position you want to use. See the following figure for drive positions.

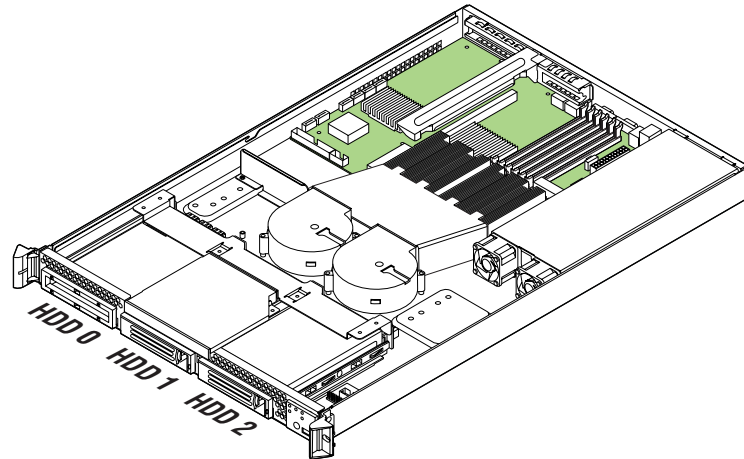

AF001619

Figure 42. Locating Drive Positions (SR1530HCL/SR1530HCLS and SR1530HCLR/SR1530HCLSR)

3. Open the latch at the front of the hard drive carrier. See letter “A” in the following figure.

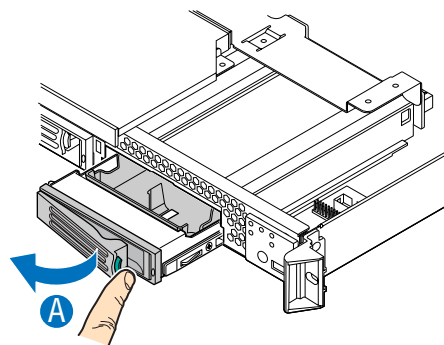

AF001620

Figure 43. Removing the Drive Carrier (SR1530HCL/SR1530HCLS and SR1530HCLR/SR1530HCLSR)

4. Pull out on the black lever and slide the carrier from the server system.
5. Remove the four screws that attach the plastic retention device or the previously installed hard drive to the drive carrier. Two screws are at each side of the retention device of the hard drive. Store the plastic retention device for future use. See letter “A” in the following figure.

Remove the hard drive from its wrapper and place it on an anti-static surface. Set any jumpers and/or switches on the drive according to the drive manufacturer’s instructions.

With the drive circuit-side down, position the connector end of the drive so that it is facing the rear of the drive carrier.

Align the holes in the drive to the holes in the drive carrier and attach the drive to the carrier with the screws that were formerly attached to the plastic retention device (see letter “B”).

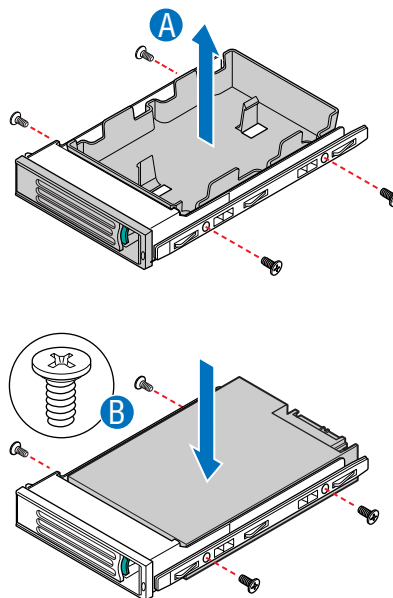

AF001621

Figure 44. Installing Drive into Drive Carrier (SR1530HCL/SR1530HCLS and SR1530HCLR/SR1530HCLSR)

6. With the black lever in the fully open position, slide the drive assembly into the server system (see letter “A” in the following figure). The green latch at the front of the drive carrier must be to the right. Do not push on the black drive carrier lever until the lever begins to close by itself.

When the black drive carrier lever begins to close by itself, push on it to lock the drive assembly into place (see letter “B”).

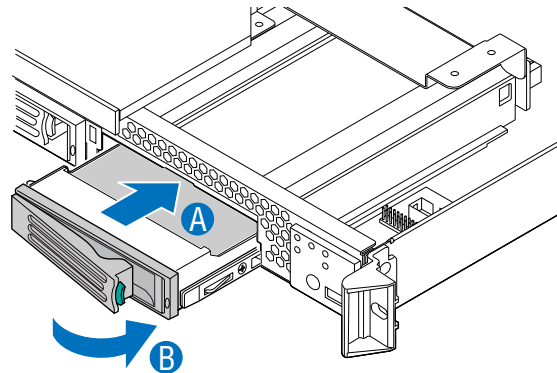

AF001622

Figure 45. Installing Drive Assembly into Server System (SR1530HCL/ SR1530HCLS and SR1530HCLR/SR1530HCLSR)

7. Install the server system cover. For instructions, see “Installing the Server System Cover” on page 30.
8. (Optional) Install the front bezel. For instructions, see “Installing the Front Bezel” on page 27.
9. Plug all peripheral devices and the AC power cable(s) into the server.

Removing a Hot-Swap SAS/SATA Drive (SR1530HCL/ SR1530HCLS and SR1530HCLR/SR1530HCLSR)

1. Remove the front bezel if it is installed. For instructions, see “Removing the Front Bezel” on page 26.
2. Press in on the green latch at the front of the hard drive carrier.
3. Pull out on the black lever to slide the carrier from the server system.
4. Remove the four screws that attach the hard drive to the drive carrier. Lift the drive from the carrier. Store the drive in an anti-static bag.
5. If you are not installing a new drive, place the plastic retention device into the drive carrier using the four screws you removed from the hard drive.
6. Insert the screws that held the drive in the carrier into the screw locations on the carrier for future use.

7. With the black lever in the fully open position, slide the drive carrier into the server system. The green latch must be to the right. Do not push on the black lever until the lever begins to close by itself.

Note: For proper airflow, the hard drive carrier must be replaced in the server system even if no hard drive is installed in it.

8. When the black lever begins to close by itself, push on it to lock the drive carrier into place.
9. Install the server system cover. For instructions, see [“Installing the Server System Cover” on page 30](#).
10. (Optional) Install the front bezel. For instructions, see [“Installing the Front Bezel” on page 27](#).
11. Plug all peripheral devices and the AC power cable(s) into the server.

Installing or Removing a Slimline Optical Drive

Caution: The optical drive is NOT hot-swappable. Before removing or replacing the optical drive, you must first take the server out of service, turn off all peripheral devices connected to the system, turn off the system by pressing the power button, and unplug the AC power cord from the system or wall outlet.

Note: Slimline optical drive installations and removal instructions differ between the different server systems. Be sure to follow the instructions that correspond to your server system.

Installing a Slimline Optical Drive (SR1530CL/SR1530CLR)

Note: If you are replacing an optical drive, see [“Removing a Slimline Optical Drive \(SR1530CL/SR1530CLR\)” on page 58](#) for instructions first. Return to these steps when directed.

Note: The hardware necessary to install your optical drive was shipped to you in a bag labeled “CD-ROM Assy”.

1. Observe the safety and ESD precautions at the beginning of this book. See [“Safety Information” on page iii](#).
2. Power down the server and unplug all peripheral devices and the AC power cable.
3. Remove the server system cover. For instructions, see [“Removing the Server System Cover” on page 28](#).
4. Remove the bezel if it is installed. For instructions, see [“Removing the Front Bezel” on page 26](#).

5. Note the orientation of the PCI cooling fan that is located behind the optical drive bay, then lift the fan from the mounting pegs. It is not necessary to disconnect the fan cable. See letter “A” in the following figure.

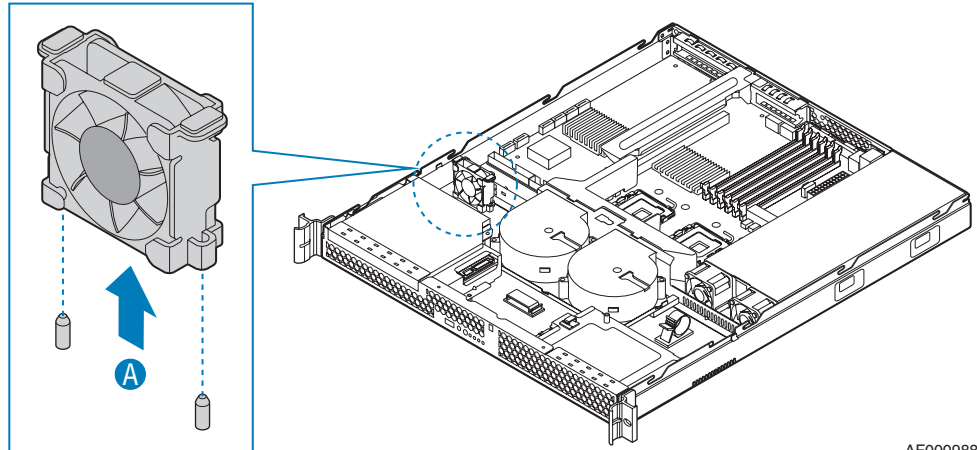

AF000988

Figure 46. Lifting PCI Cooling Fan from Mounting Pegs (SR1530CL/ SR1530CLR)

6. First time installation only: Remove the knockout in the bezel that corresponds to the opening for the optical drive by rocking it back and forth (see letter “A” in the following figure). The knockout cannot be reinstalled.

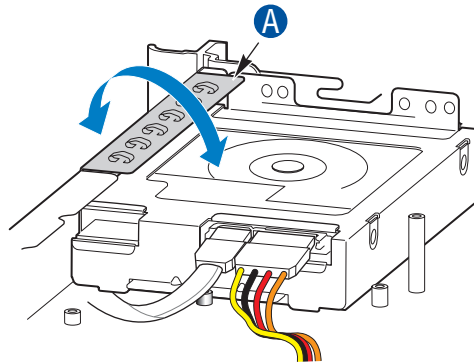

AF001172

Figure 47. Removing the Knockout in Bezel for Optical Drive Opening (SR1530CL/SR1530CLR)

7. Attach the interposer board to the rear of the CD-ROM or DVD-ROM drive (see letter “A” in the following figure). Secure the interposer board to the rear of the CD-ROM or DVD-ROM drive with two screws (see letter “B”).

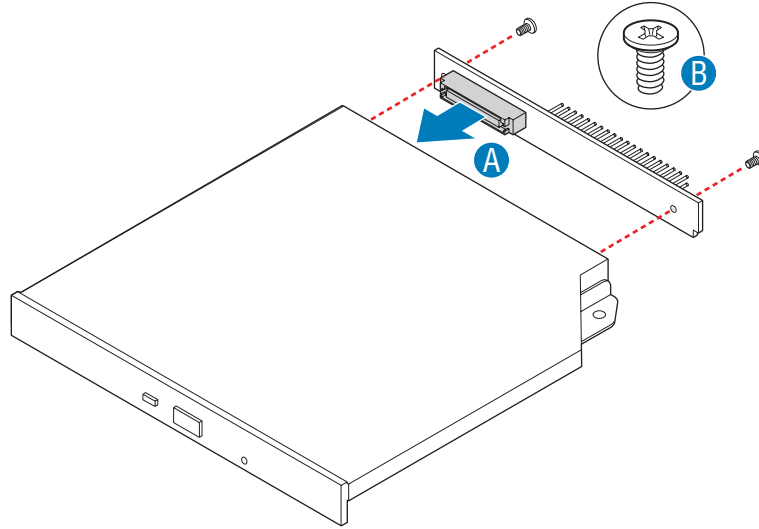

AF001186

Figure 48. Attaching the Interposer Board (SR1530CL/SR1530CLR)

8. Attach the brackets to the optical drive using four screws as shown in the following figure.

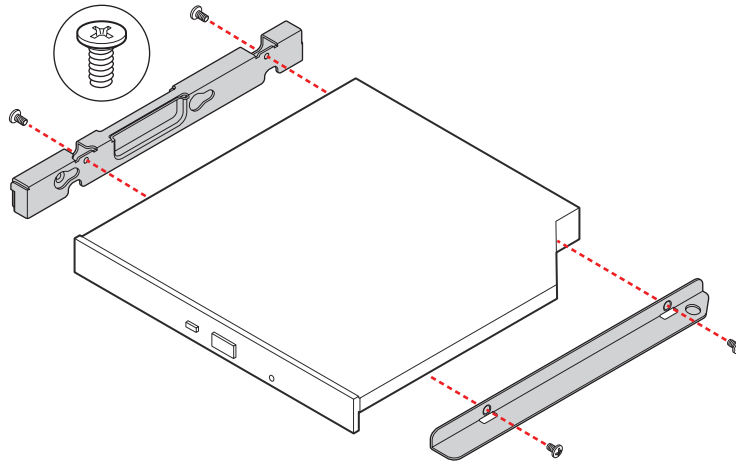

AF000672

Figure 49. Attaching the Brackets to the Optical Drive (SR1530CL/SR1530CLR)

9. Slide the optical drive assembly in through the front of the chassis, as shown by letter “A” in the following figure. Secure the optical drive to the chassis with a screw (see letter “B”). Route the power cable through the clip in front of the system fans and connect it to the power connector on the optical drive (see letter “C”). Connect the data cable to the optical drive and to the IDE connector on the server board (see letter “D”).

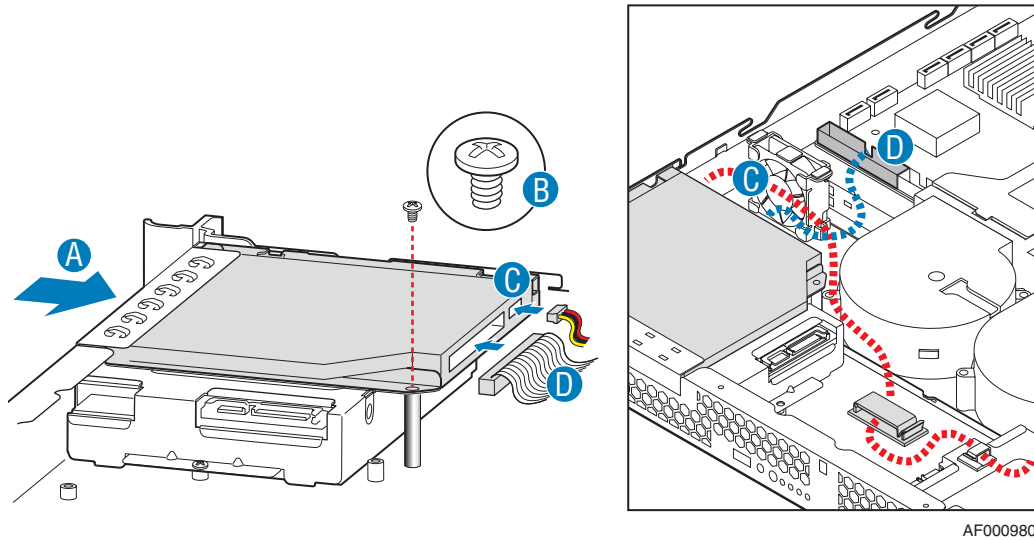

AF000980

Figure 50. Installing the Optical Drive into the Server System (SR1530CL/SR1530CLR)

10. Install the PCI cooling fan onto the mounting pegs that are located behind the optical drive bay. The fan label should face the rear of the system. See letter “A” in the following figure.

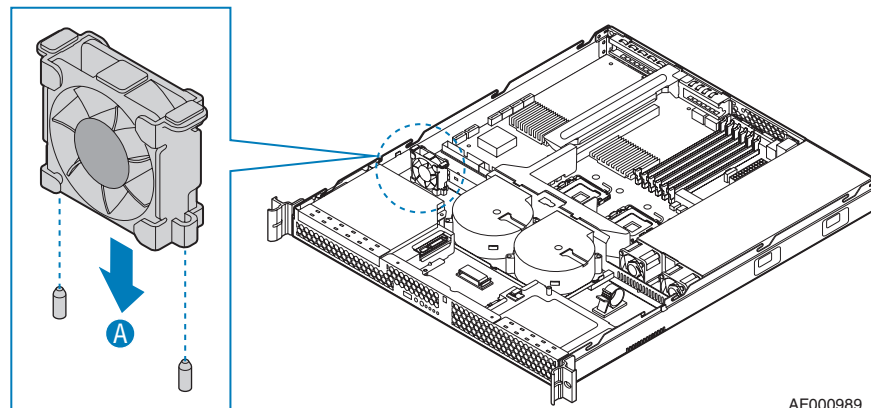

AF000989

Figure 51. Installing PCI Cooling Fan (SR1530CL/SR1530CLR)

11. Install the server system cover. For instructions, see “Installing the Server System Cover” on page 30.
12. Optional: Install the front bezel. For instructions, see “Installing the Front Bezel” on page 27.

13. Plug all peripheral devices and the AC power cable into the server.

Installing a Slimline Optical Drive (SR1530HCL/SR1530HCLS and SR1530HCLR/SR1530HCLSR)

Note: If you are replacing an optical drive, see “[Removing a Slimline Optical Drive \(SR1530CL/SR1530CLR\)](#)” on page 58 for instructions first. Return to these steps when directed.

Note: The hardware necessary to install your optical drive was shipped to you in a bag labeled “CD-ROM Assy”.

1. Observe the safety and ESD precautions at the beginning of this book. See “[Safety Information](#)” on page iii.
2. Power down the server and unplug all peripheral devices and the AC power cable.
3. Remove the server system cover. For instructions, see “[Removing the Server System Cover](#)” on page 28.
4. Remove the bezel if it is installed. For instructions, see “[Removing the Front Bezel](#)” on page 26.
5. Attach the interposer board to the rear of the CD-ROM or DVD-ROM drive, using two screws, as shown by the following figure.

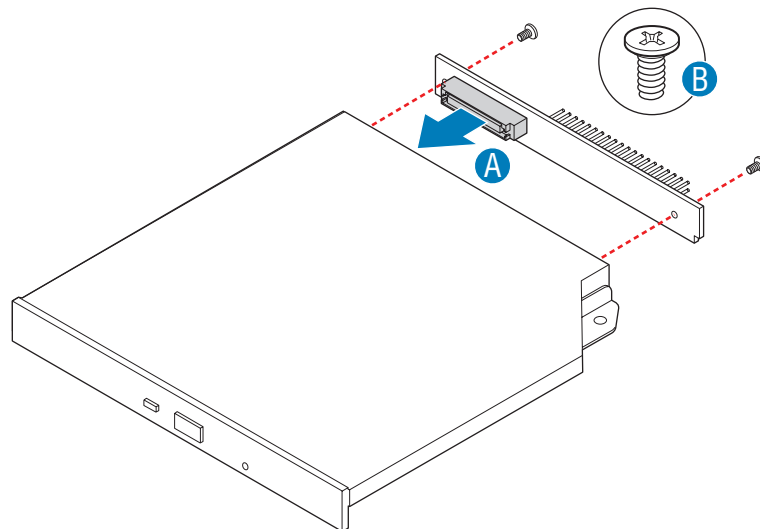

AF001186

Figure 52. Attaching the Interposer Board (SR1530HCL/SR1530HCLS and SR1530HCLR/SR1530HCLSR)

6. Attach the bracket to the optical drive using two screws, as shown in the following figure.

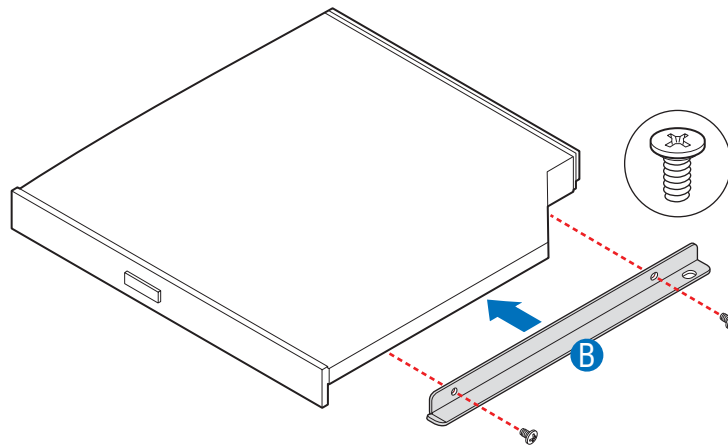

AF000958

**Figure 53. Attaching the Bracket to the Optical Drive (SR1530HCL/
SR1530HCLS and SR1530HCLR/SR1530HCLSR)**

7. (First-time installation only) Remove the knockout in the bezel that corresponds to the opening for the optical slimline drive.
8. Slide the optical drive in through the front of the chassis (see letter “A” in the following figure). Secure the optical drive to the chassis with one screw (see letter “B”).

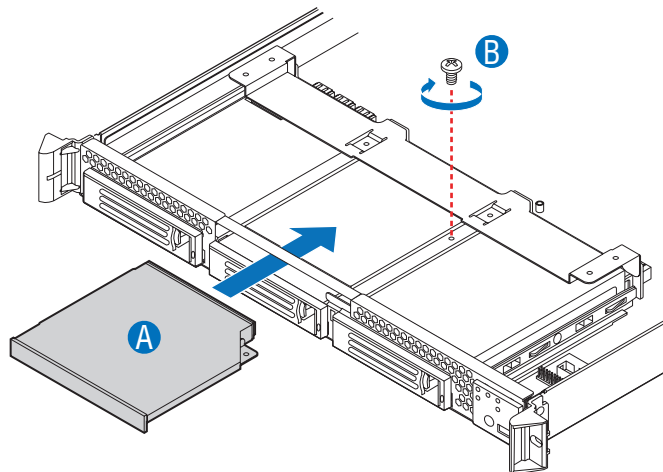

AF001636

**Figure 54. Installing the Optical Drive into the System (SR1530HCL/
SR1530HCLS and SR1530HCLR/SR1530HCLSR)**

9. Connect the power cable to the power connector on the optical drive. Connect the data cable between the connector on the optical drive and the IDE connector on the server board.

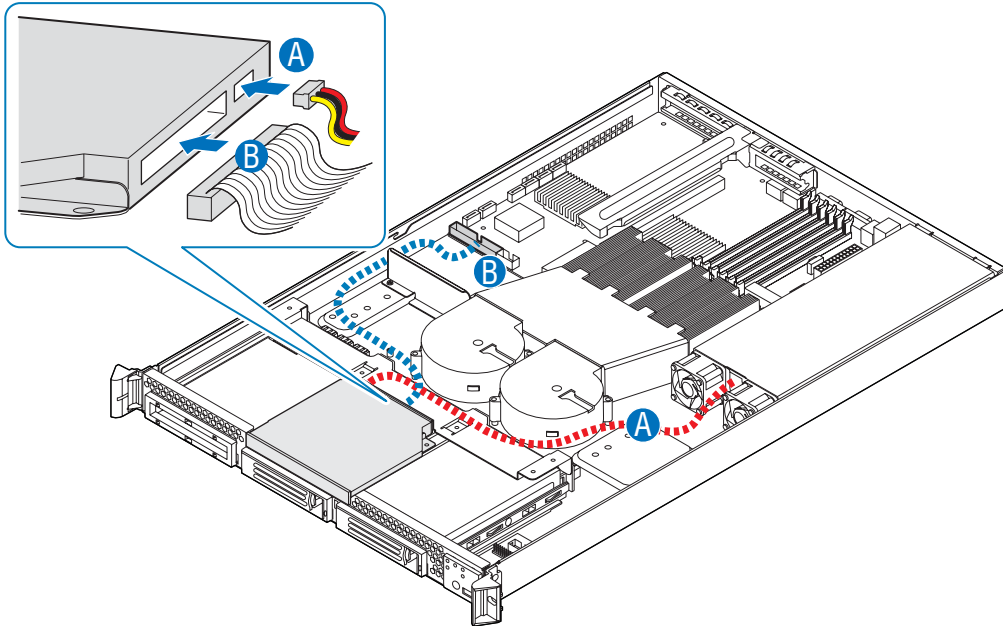

AF001647

Figure 55. Routing Data and Power Cables to Optical Drive (SR1530HCL/SR1530HCLS and SR1530HCLR/SR1530HCLSR)

10. Install the server system cover. For instructions, see “Installing the Server System Cover” on page 30.
11. Optional: Install the front bezel. For instructions, see “Installing the Front Bezel” on page 27.
12. Plug all peripheral devices and the AC power cable into the server.

Removing a Slimline Optical Drive (SR1530CL/SR1530CLR)

1. Observe the safety and ESD precautions at the beginning of this book. See “[Safety Information](#)” on page iii.
2. Power down the server and unplug all peripheral devices and the AC power cable.
3. Remove the server system cover. For instructions, see “[Removing the Server System Cover](#)” on page 28.
4. Remove the front bezel if it is installed. For instructions, see “[Removing the Front Bezel](#)” on page 26.
5. Note the orientation of the PCI cooling fan that is located behind the optical drive bay, then lift the fan from the mounting pegs. It is not necessary to disconnect the fan cable. See letter “A” in the following figure.

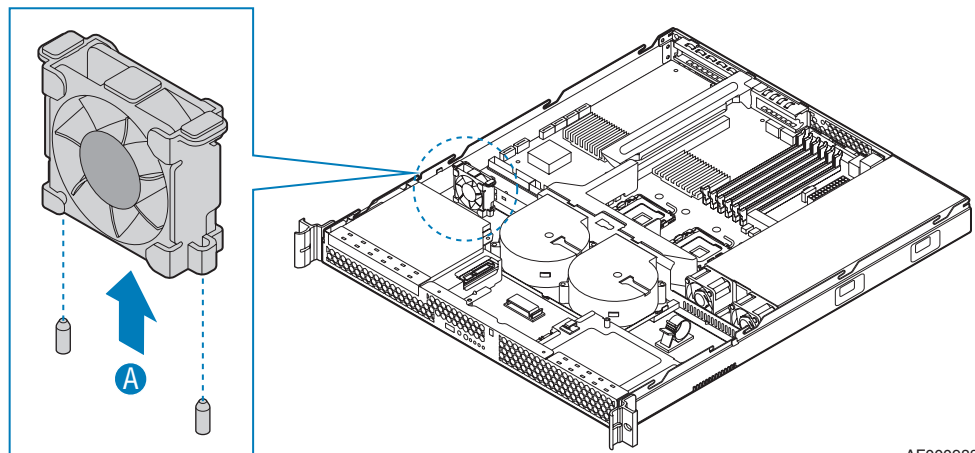
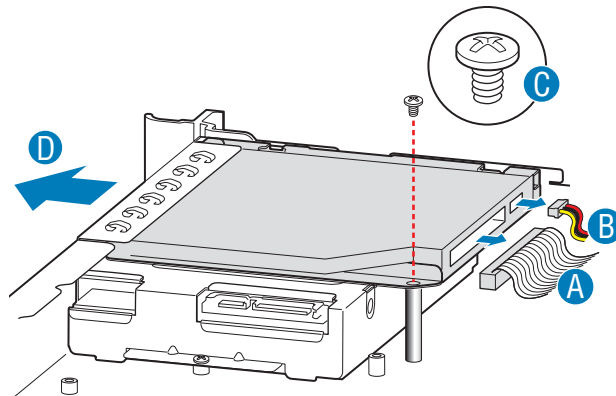

Figure 56. Lifting PCI Cooling Fan from Mounting Pegs (SR1530CL/SR1530CLR)

6. Disconnect the optical drive power and data cables. See letters “A” and “B” in the following figure.
7. Remove the screw that holds the optical drive bracket to the server chassis. See letter “C”. Save this screw. You will reinstall it later.
8. Slide the optical drive out through the front of the system. See letter “D”.



AF000670

Figure 57. Removing the Optical Drive from the Server System (SR1530CL/ SR1530CLR)

9. Remove the four screws that attach the brackets to the optical drive, as shown in the following figure. Save these screws for future use.

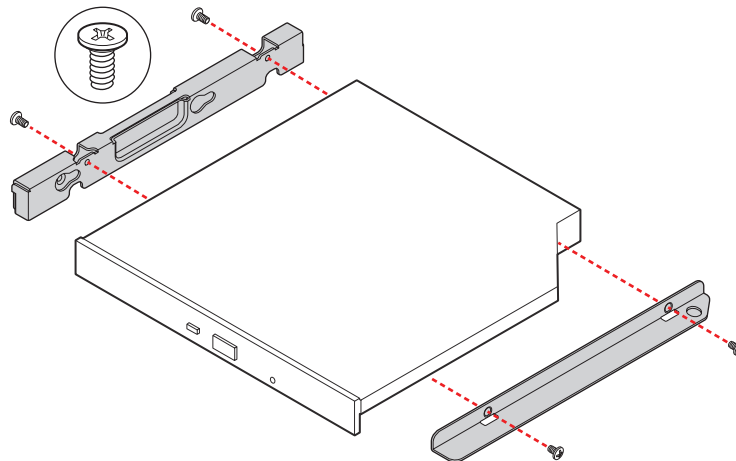

AF000672

Figure 58. Removing the Brackets from the Optical Drive Bracket (SR1530CL/SR1530CLR)

10. Remove the two screws at the back of the CD-ROM or DVD-ROM drive to detach the interposer board from the drive (see letter “A” in the following figure). Carefully pull the interposer board from the drive, detaching the interposer board connector from the drive (see letter “B”).

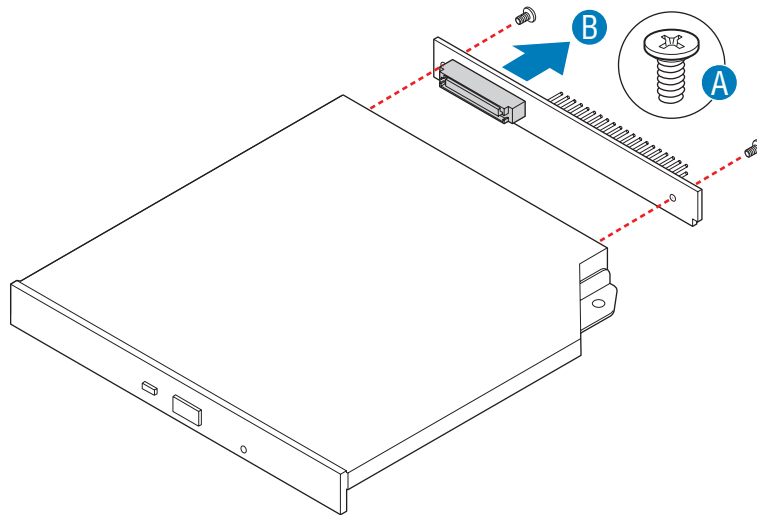

AF001203

Figure 59. Removing the Interposer Board from the Optical Drive (SR1530CL/SR1530CLR)

11. If you are installing a replacement optical drive, skip the rest of these steps and instead continue with "[Installing a Slimline Optical Drive \(SR1530CL/SR1530CLR\)](#)", step 7 on page 53.
12. Store the brackets and interposer board for future use.
13. Insert the PCI cooling fan onto the mounting pegs that are located behind the optical drive bay. The fan label should face the rear of the system. See letter “A” in the following figure.

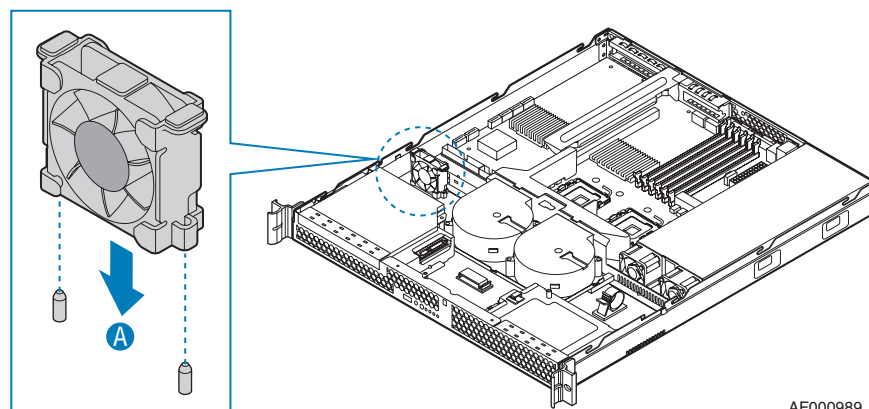

AF000989

Figure 60. Installing the PCI Cooling Fan onto Mounting Pegs (SR1530CL/SR1530CLR)

- Optional: Install the front bezel. For instructions, see [“Installing the Front Bezel” on page 27](#).
- Install the server system cover. For instructions, see [“Installing the Server System Cover” on page 30](#).

Removing a Slimline Optical Drive (SR1530HCL/ SR1530HCLS and SR1530HCLR/SR1530HCLSR)

- Observe the safety and ESD precautions at the beginning of this book. See [“Safety Information” on page iii](#).
- Power down the server and unplug all peripheral devices and the AC power cable.
- Remove the server system cover. For instructions, see [“Removing the Server System Cover” on page 28](#).
- Remove the front bezel if it is installed. For instructions, see [“Removing the Front Bezel” on page 26](#).
- Disconnect the optical drive power and data cables (see letters “A” and “B” in the following figure). Remove the screw that secures the optical drive bracket to the server chassis (see letter “C”). Save this screw. You will reinstall it later. Slide the optical drive out through the front of the system (see letter “D”).

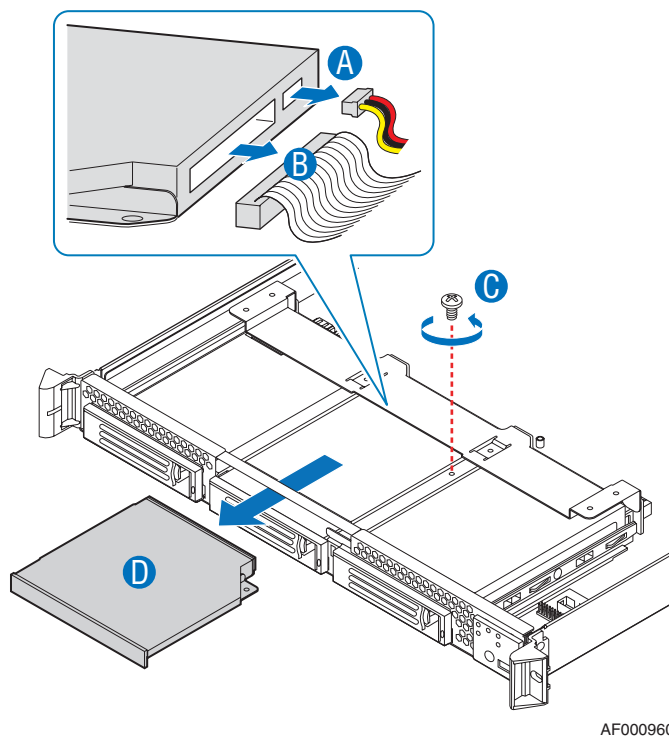

AF000960

Figure 61. Removing Optical Drive from Server System (SR1530HCL/ SR1530HCLS and SR1530HCLR/SR1530HCLSR)

6. Remove the two screws that secure the bracket to the optical drive, as shown in the following figure. Save these screws and the bracket for future use.

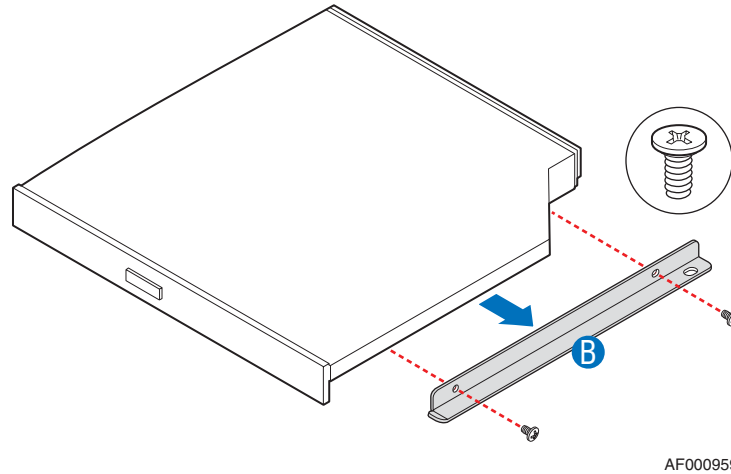

Figure 62. Removing Bracket from Optical Drive Bracket (SR1530HCL/ SR1530HCLS and SR1530HCLR/SR1530HCLSR)

7. Remove the two screws at the back of the CD-ROM or DVD-ROM drive to detach the interposer board (see letter “A” in the following figure). Carefully pull the interposer board from the drive, detaching the interposer board connector from the drive (see letter “B”).

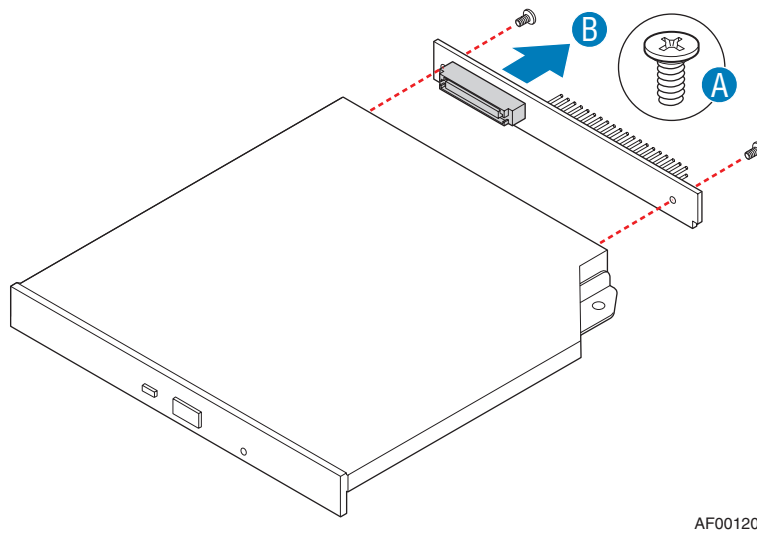

Figure 63. Removing Interposer Board from Optical Drive (SR1530HCL/ SR1530HCLS and SR1530HCLR/SR1530HCLSR)

8. If you are installing a replacement optical drive, skip the rest of these steps and instead continue with "Installing a Slimline Optical Drive (SR1530HCL/ SR1530HCLS and SR1530HCLR/SR1530HCLSR)", step 5.

9. Store the brackets and interposer board for future use.
10. Optional: Install the front bezel. For instructions, see [“Installing the Front Bezel” on page 27](#).
11. Install the server system cover. For instructions, see [“Installing the Server System Cover” on page 30](#).

Installing and Removing the PCI Riser Assembly

Caution: *The PCI riser assembly is NOT hot-swappable. Before removing or replacing the PCI riser assembly, you must first take the server out of service, turn off all peripheral devices connected to the system, turn off the system by pressing the power button, and unplug the AC power cord from the system or wall outlet.*

Removing the PCI Riser Assembly

1. Observe the safety and ESD precautions at the beginning of this book. See [“Safety Information” on page iii](#).
2. Power down the server and unplug all peripheral devices and the AC power cable.
3. Remove the server system cover. For instructions, see [“Removing the Server System Cover” on page 28](#).
4. Disconnect any cables attached to any add-in cards.
5. Lift the riser assembly up to remove it. Use caution to gently ease the riser card from the add-in card slot so you do not damage the slot or the riser card.

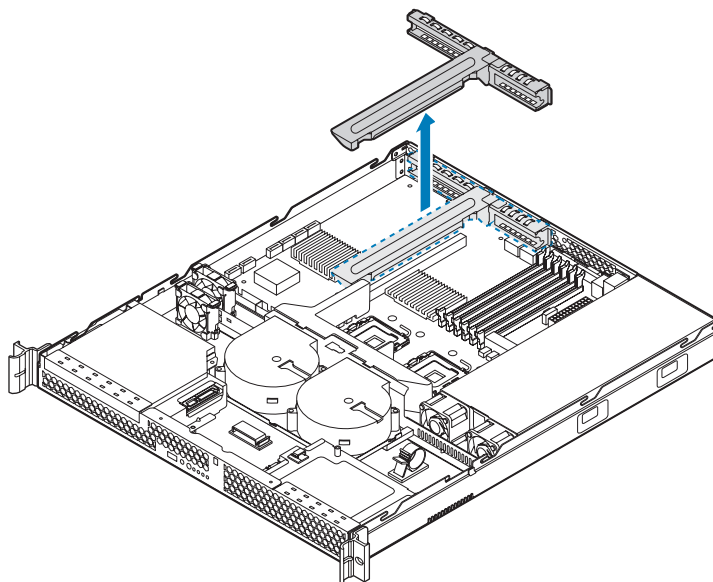

AF000982

Figure 64. Removing PCI Riser Assembly from the Server System

6. If you need to add or remove a PCI riser card, see [“Installing or Replacing a PCI Riser Card”](#) on page 65.
7. If you need to add or remove a PCI add-in card, see [“Installing or Removing a PCI Add-in Card”](#) on page 67.
8. If you removed the PCI riser assembly for another procedure, continue with that procedure.

Installing the PCI Riser Assembly

Note: For clarity, the figure in this series of instructions does not show an attached add-in card. If you are installing an add-in card, do so before installing the PCI riser assembly into your server system.

1. Lower the PCI riser assembly into place over the add-in card slot. See letter “A” in the following figure.
2. Align the three hooks in the PCI riser assembly with the matching slots at the back of the server system. See letters “B” and “C” in the figure.

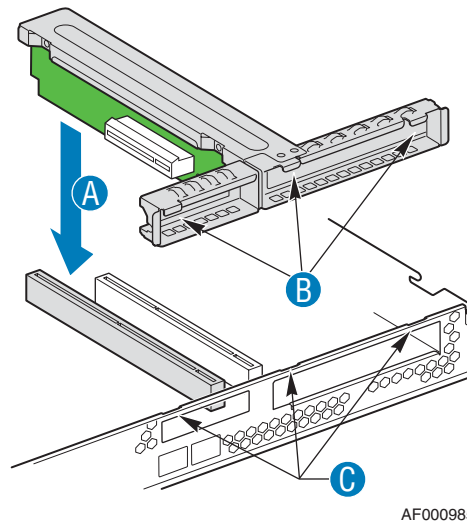

AF000985

Figure 65. Installing PCI Riser Assembly into the Server System

3. Press down uniformly until the two hooks on the rear of the PCI riser assembly engage the server system back panel slots. The riser cards will seat into the matching sockets on the server board.
4. Connect any cables to add-in cards that require them. See your add-in card documentation for information and add-in card requirements.
5. Install the server system cover. For instructions, see [“Installing the Server System Cover”](#) on page 30.

Installing or Replacing a PCI Riser Card

Caution: The PCI riser card is NOT hot-swappable. Before removing or replacing the PCI riser card, you must first take the server out of service, turn off all peripheral devices connected to the system, turn off the system by pressing the power button, and unplug the AC power cord from the system or wall outlet.

The PCI riser card has two available slots:

- One PCI Express* x8 slot to accommodate a low profile PCI Express* card. The card must be installed on the right side of the bracket.
- One PCI-X* slot to accommodate a full-height/mid-length PCI-X* card. The card must be installed on the left side of the bracket.

Installing a PCI Riser Card

1. Observe the safety and ESD precautions at the beginning of this book. See [“Safety Information”](#) on page iii.
2. Power down the server and unplug all peripheral devices and the AC power cable.
3. Remove the server system cover. For instructions, see [“Removing the Server System Cover”](#).
4. Disconnect any cables attached to any add-in cards.
5. Remove the PCI riser assembly. For instructions, see [“Removing the PCI Riser Assembly”](#) on page 63.
6. Use two screws to attach the PCI riser card to the PCI riser assembly. See the following figure.

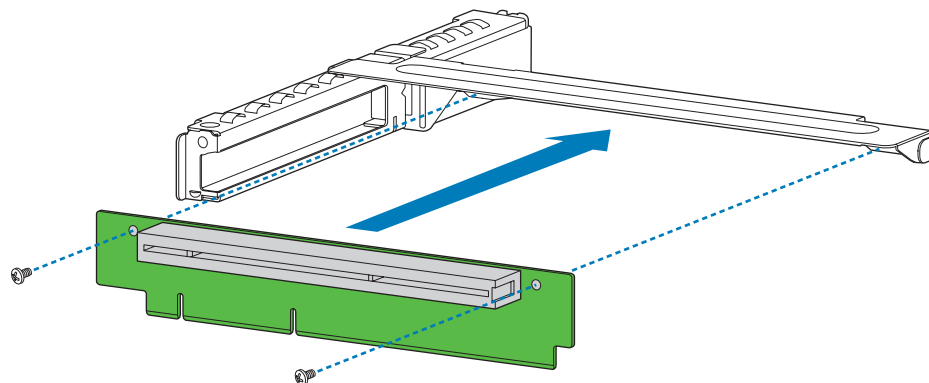

AF001062

Figure 66. Installing Riser Card onto Riser Assembly

7. Install PCI add-in card(s) if desired. For instructions, see [“Installing a PCI Add-in Card”](#) on page 67.
8. Install the PCI riser assembly into the server system. For instructions, see [“Installing the PCI Riser Assembly”](#) on page 64.

9. Connect any cables to add-in cards that require them. See your add-in card documentation for information and add-in card requirements.
10. Install the server system cover. For instructions, see [“Installing the Server System Cover” on page 30](#).
11. Plug all peripheral devices and the AC power cable into the server.

Replacing a PCI Riser Card

1. Observe the safety and ESD precautions at the beginning of this book. See [“Safety Information” on page iii](#).
2. Power down the server and unplug all peripheral devices and the AC power cable.
3. Remove the server system cover. For instructions, see [“Removing the Server System Cover” on page 28](#).
4. Disconnect any cables attached to any add-in cards.
5. Remove the PCI riser assembly. For instructions, see [“Removing the PCI Riser Assembly” on page 63](#).
6. Remove any add-in cards from the existing PCI riser connector. For instructions, see [“Removing a PCI Add-in Card” on page 68](#).
7. Remove the two screws that attach the existing riser card to the riser assembly. See the following figure. Save these screws to be used later.

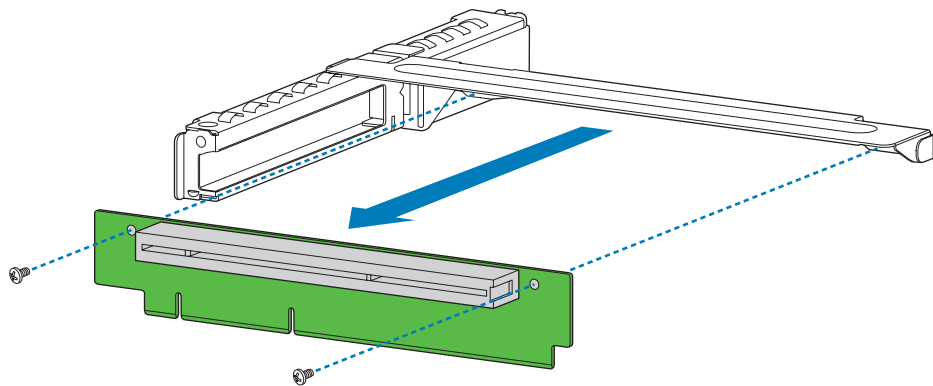

AF001063

Figure 67. Removing Riser Card from Riser Assembly

8. Install the replacement PCI riser card, if desired. For instructions, see [“Installing a PCI Riser Card” on page 65](#).
9. Install the PCI riser assembly into the server system. For instructions, see [“Installing the PCI Riser Assembly” on page 64](#).
10. Install the server system cover. For instructions, see [“Installing the Server System Cover” on page 30](#).
11. Plug all peripheral devices and the AC power cable into the server.

Installing or Removing a PCI Add-in Card

Caution: *The add-in cards are NOT hot-swappable. Before installing or removing an add-in card, you must first take the server out of service, turn off all peripheral devices connected to the system, turn off the system by pressing the power button, and unplug the AC power cord from the system or wall outlet.*

One PCI-X* and one PCI Express* add-in card can be installed. The PCI-X card must be installed at the left side of the bracket; the PCI Express card must be installed at the right side of the bracket.

Installing a PCI Add-in Card

1. Observe the safety and ESD precautions at the beginning of this book. See [“Safety Information”](#) on page iii.
2. Power down the server and unplug all peripheral devices and the AC power cable.
3. Remove the server system cover. For instructions, see [“Removing the Server System Cover”](#) on page 28.
4. Remove the PCI riser assembly. For instructions, see [“Removing the PCI Riser Assembly”](#) on page 63.
5. Remove the screw at the rear of the riser assembly. See letter “A” in [Figure 68](#). Save this screw. You will reinstall it later.
6. If a filler panel is installed over the opening at the rear of the riser assembly lift it from the riser assembly. See letter “B” in the figure. Save the filler panel in case you later need to remove the add-in card.
7. Insert the add-in card into the socket in the riser assembly. Push the add-in card into place firmly until it seats in the riser card connector, but use caution so you do not twist or bend the card. See letter “C” in the figure.

8. Re-install the screw you removed in step 5. See letter “A” in the figure.

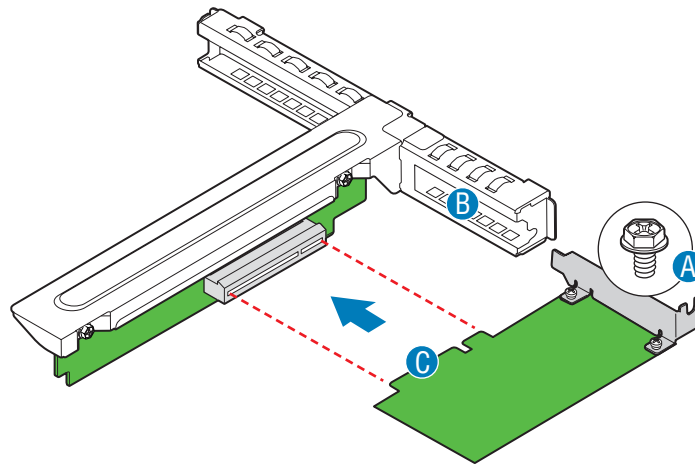

AF000983

Figure 68. Installing an Add-In Card

9. Install the PCI riser assembly into the server system. For instructions, see [“Installing the PCI Riser Assembly” on page 64](#).
10. Install the server system cover. For instructions, see [“Installing the Server System Cover” on page 30](#).
11. Plug all peripheral devices and the AC power cable into the server.

Removing a PCI Add-in Card

1. Observe the safety and ESD precautions at the beginning of this book. See [“Safety Information” on page iii](#).
2. Power down the server and unplug all peripheral devices and the AC power cable.
3. Remove the server system cover. For instructions, see [“Removing the Server System Cover” on page 28](#).
4. Remove the PCI riser assembly. For instructions, see [“Removing the PCI Riser Assembly” on page 63](#).
5. Remove the screw at the rear of the riser assembly. See letter “A” in [Figure 69](#). Save this screw. You will use it later.
6. Pull the add-in card from the socket in the riser assembly. You may need to wriggle the card from front to back to remove it, but use caution to not twist or bend the card. See letter “B” in the figure.
7. Install a filler panel over the opening at the rear of the riser assembly. See letter “C” in the figure.

8. Re-install the screw you removed in step 5. See letter “A” in the figure.

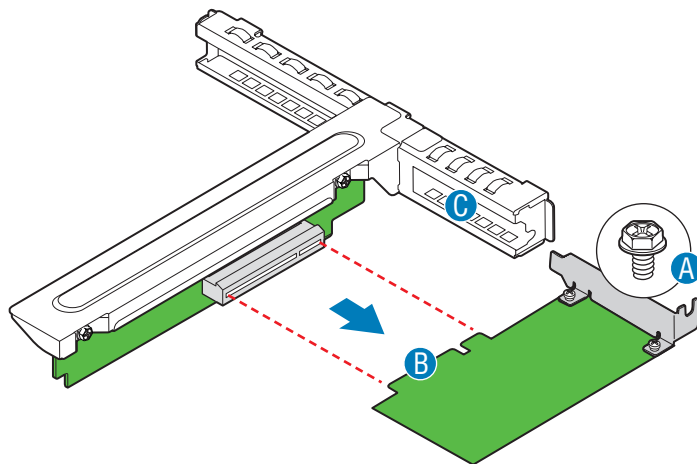

AF000984

Figure 69. Removing an Add-In Card

Note: Make sure that all empty add-in card slots have filler panels installed.

9. Install the PCI riser assembly into the server system. For instructions, see “Installing the PCI Riser Assembly” on page 64.
10. Install the processor air duct. For instructions, see “Installing the Processor Air Duct” on page 33.
11. Install the server system cover. For instructions, see “Installing the Server System Cover” on page 30.
12. Plug all peripheral devices and the AC power cable into the server.

Installing and Removing the Server Board

Installing the Server Board

1. Observe the safety and ESD precautions at the beginning of this book. See “Safety Information” on page iii.
2. Power down the server and unplug all peripheral devices and the AC power cable.
3. Remove the server system cover. For instructions, see “Removing the Server System Cover” on page 28.
4. Remove the processor air duct. For instructions, see “Removing the Processor Air Duct” on page 32.
5. Remove the PCI riser assembly. For instructions, see “Removing the PCI Riser Assembly” on page 63.

- Place the server board into the server system, as shown by letter “A” in the following figure. Attach the server board with six screws (see letter “B”).

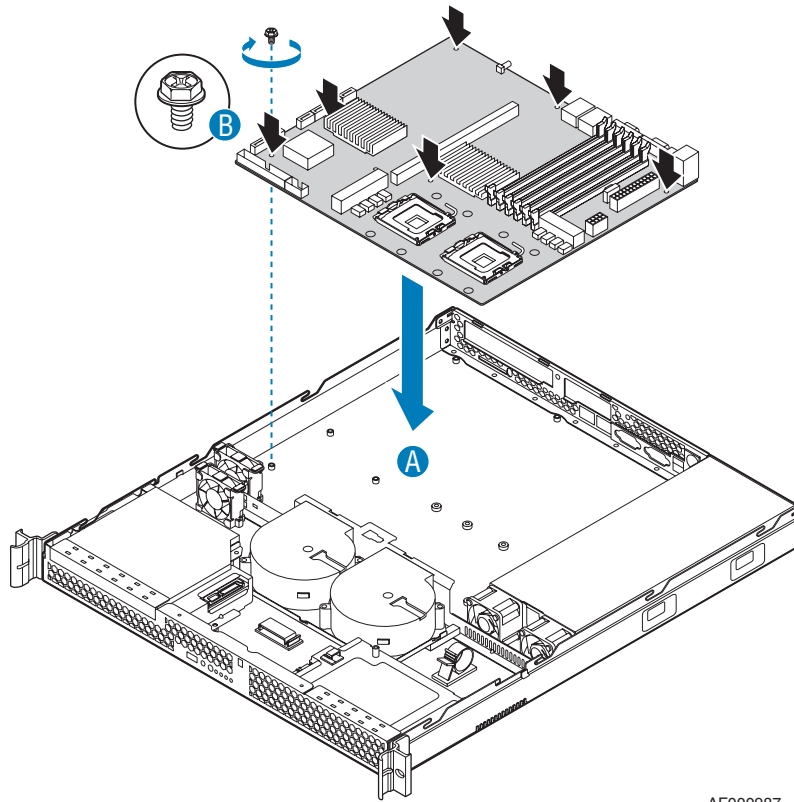

AF000987

Figure 70. Installing the Server Board

- Install the processor and the heat sink. For instructions, see [“Installing the Processor”](#) on page 37 and [“Installing the Heat Sink”](#) on page 40.
- Install the system memory. For instructions, see [“Installing DIMMs”](#) on page 35.
- Connect the data cables. For instructions, see [“Cable Routing”](#) on page 97.
- Connect the power cables. For instructions, see [“Cable Routing”](#) on page 97.
- Install the PCI riser assembly. For instructions, see [“Installing the PCI Riser Assembly”](#) on page 64.
- Install the processor air duct. For instructions, see [“Installing the Processor Air Duct”](#) on page 33.
- Install the server system cover. For instructions, see [“Installing the Server System Cover”](#) on page 30.
- Plug all peripheral devices and the AC power cable into the server.

Removing the Server Board

1. Observe the safety and ESD precautions at the beginning of this book. See “[Safety Information](#)” on page iii.
2. Power down the server and unplug all peripheral devices and the AC power cable.
3. Remove the server system cover. For instructions, see “[Removing the Server System Cover](#)” on page 28.
4. Remove the processor air duct. For instructions, see “[Removing the Processor Air Duct](#)” on page 32.
5. Remove the PCI riser assembly. For instructions, see “[Removing the PCI Riser Assembly](#)” on page 63.
6. Detach all cables connected to the server board.
7. Remove the heat sink and the processor. For instructions, see “[Removing the Heat Sink and Processor](#)” on page 41.
8. Remove the DIMMs. For instructions, see “[Removing DIMMs](#)” on page 37.
9. Remove the six screws from the server board. See letter “A” in the following figure. Lift the server board from the server system (see letter “B”).

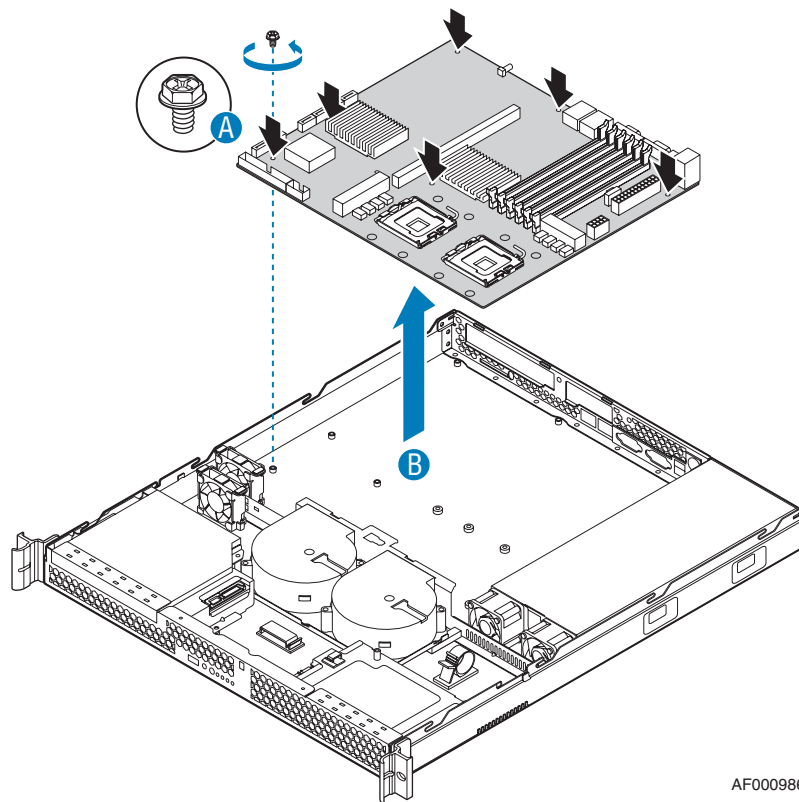

AF000986

Figure 71. Removing the Server Board

10. Replace the server board. For instructions, see [“Installing the Server Board” on page 69](#).
11. Install the processor(s) and heat sinks. For instructions, see [“Installing the Processor” on page 37](#) and [“Installing the Heat Sink” on page 40](#).
12. Install the DIMMs. For instructions, see [“Installing DIMMs” on page 35](#).
13. Install the PCI riser assembly. For instructions, see [“Installing the PCI Riser Assembly” on page 64](#).
14. Reconnect all cables to the server board. For instructions, see [“Cable Routing” on page 97](#).
15. Install the processor air duct. For instructions, see [“Installing the Processor Air Duct” on page 33](#).
16. Install the server system cover. For instructions, see [“Installing the Server System Cover” on page 30](#).
17. Plug all peripheral devices and the AC power cable into the server.

Replacing the CMOS Battery

Caution: *The CMOS battery is NOT hot-swappable. Before removing or replacing the CMOS battery, you must first take the server out of service, turn off all peripheral devices connected to the system, turn off the system by pressing the power button, and unplug the AC power cord from the system or wall outlet.*

The lithium battery on the server board powers the RTC in the absence of power. When the battery starts to weaken, it loses voltage, and the server settings stored in CMOS RAM in the RTC (for example, the date and time) may be wrong. Contact your customer service representative or dealer for a list of approved devices.

Warning: *Danger of explosion if battery is incorrectly replaced. Replace only with the same or equivalent type recommended by the equipment manufacturer. Discard used batteries according to manufacturer's instructions.*

Advarsel: Lithiumbatteri - Eksplosionsfare ved fejlagtig håndtering. Udskiftning må kun ske med batteri af samme fabrikat og type. Levér det brugte batteri tilbage til leverandøren.

Advarsel: Lithiumbatteri - Eksplosjonsfare. Ved utskifting benyttes kun batteri som anbefalt av apparatfabrikanten. Brukt batteri returneres apparatleverandøren.

Varning: Explosionsfara vid felaktigt batteribyte. Använd samma batterityp eller en ekvivalent typ som rekommenderas av apparattillverkaren. Kassera använt batteri enligt fabrikantens instruktion.

Varoitus: Paristo voi räjähtää, jos se on virheellisesti asennettu. Vaihda paristo ainoastaan laitevalmistajan suosittelemaan tyyppiin. Hävitä käytetty paristo valmistajan ohjeiden mukaisesti.

1. Observe the safety and ESD precautions at the beginning of this book. See [“Safety Information” on page iii](#).
2. Power down the server and unplug all peripheral devices and the AC power cable.
3. Remove the server system cover. For instructions, see [“Removing the Server System Cover” on page 28](#).
4. Locate the battery. See [Figure 72](#).
5. Insert the tip of a small flat-bladed screwdriver, or an equivalent, under the tab in the plastic retainer. Gently push down on the screwdriver to lift the battery.
6. Remove the battery from its socket.

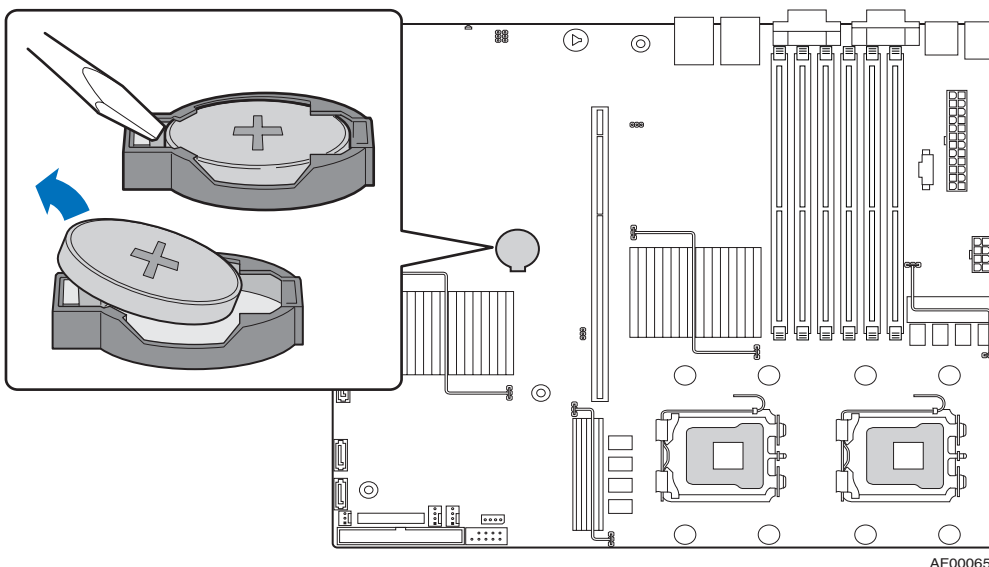

AF000656

Figure 72. Replacing the CMOS Battery

7. Dispose of the battery according to local ordinance.
8. Remove the new lithium battery from its package, and, being careful to observe the correct polarity, insert it in the battery socket.
9. Close the chassis.
10. Run the BIOS Setup utility to restore the configuration settings.

Replacing the Power Supply (SR1530CL/ SR1530CLR)

The power supply can be replaced if it fails or if one of the fans that is integrated into it fails. To replace the power supply, use the following instructions.

1. Observe the safety and ESD precautions at the beginning of this book. See [“Safety Information” on page iii](#).

2. Power down the server and unplug all peripheral devices and the AC power cable.
3. Remove the server system cover. For instructions, see [“Removing the Server System Cover”](#).
4. Disconnect all power cables connected to the server board and peripherals:
 - A: Aux power signal
 - B: 2x12 main power connector
 - C: 2x4 power connector
 - D: Daisy-chain cable to:
 - ◇ Optical drive power, if optical drive is installed
 - ◇ HDD0 power connector, if a hard drive is installed here
 - ◇ HDD1 power connector, if a hard drive is installed here

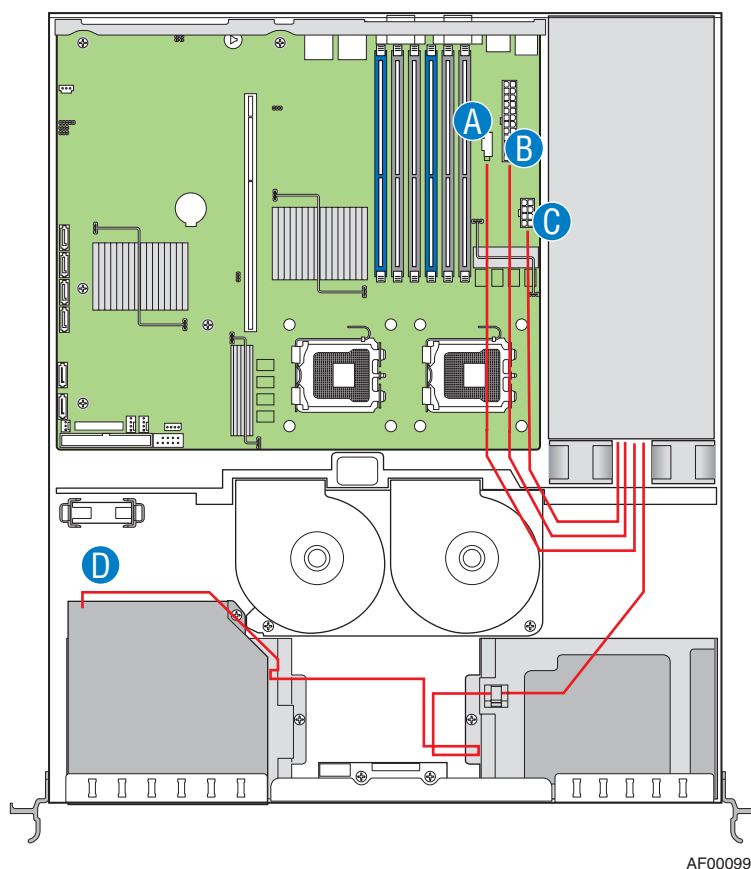

AF000998

Figure 73. Disconnecting Power Cables (SR1530CL/SR1530CLR)

5. Remove the screw at the back of the server system, next to the AC power input. Save this screw. You will re-insert it later (see letter “A” in the following figure).

Lift up slightly on the front of the power supply until it clears the foot at the bottom of the chassis (see letter “B”).

Slide the power supply forward (see letter “C”) and then lift it from the chassis.

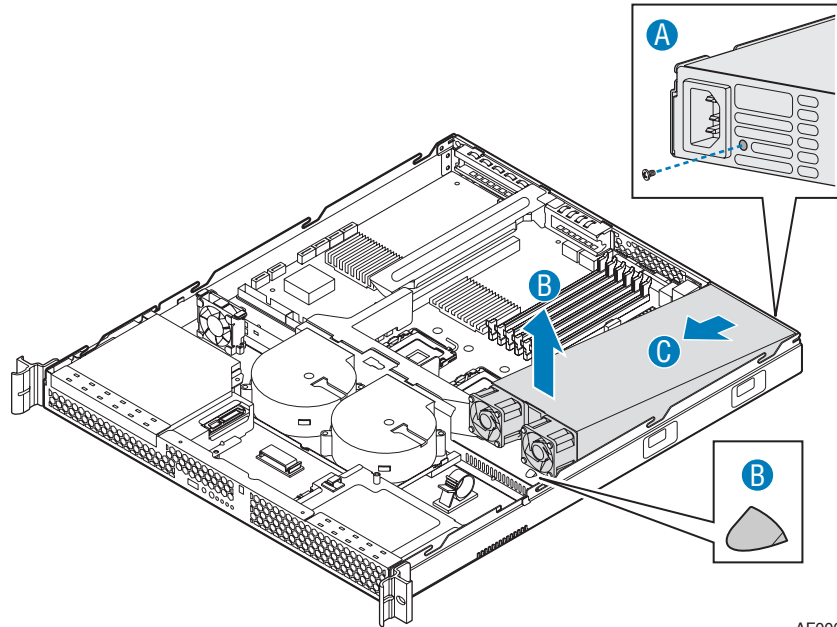

AF000994

Figure 74. Removing Power Supply from the Server System (SR1530CL/ SR1530CLR)

6. Insert the replacement power supply at an angle into the server system, sliding the power connector side in first to fit it through the cut-out area at the rear of the system (see letter “A” in the following figure).

Set the front of the power supply down pushing the power supply back so it fits behind the foot at the bottom of the chassis (see letter “B”).

Insert the screw you removed in previously to attach the power supply to the server system (see letter “C”).

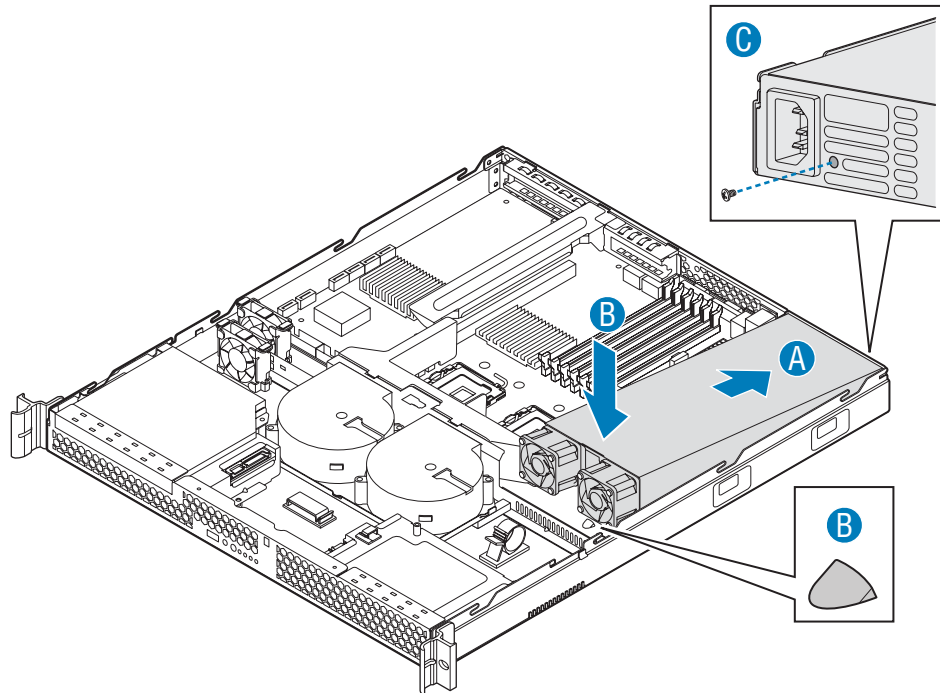

AF000995

Figure 75. Installing Power Supply into the Server System (SR1530CL/ SR1530CLR)

7. Connect the power supply cables to the server board and peripherals.

- A: Aux power signal
- B: 2x12 main power connector
- C: 2x4 power connector
- D: Daisy-chain cable to:
 - ❖ HDD1 power connector, if a hard drive is installed here. Use connector on cable that is closest to power supply.
 - ❖ HDD0 power connector, if a hard drive is installed here. Use center connector on the cable.
 - ❖ Optical drive power, if optical drive is installed. Use end connector on the cable.

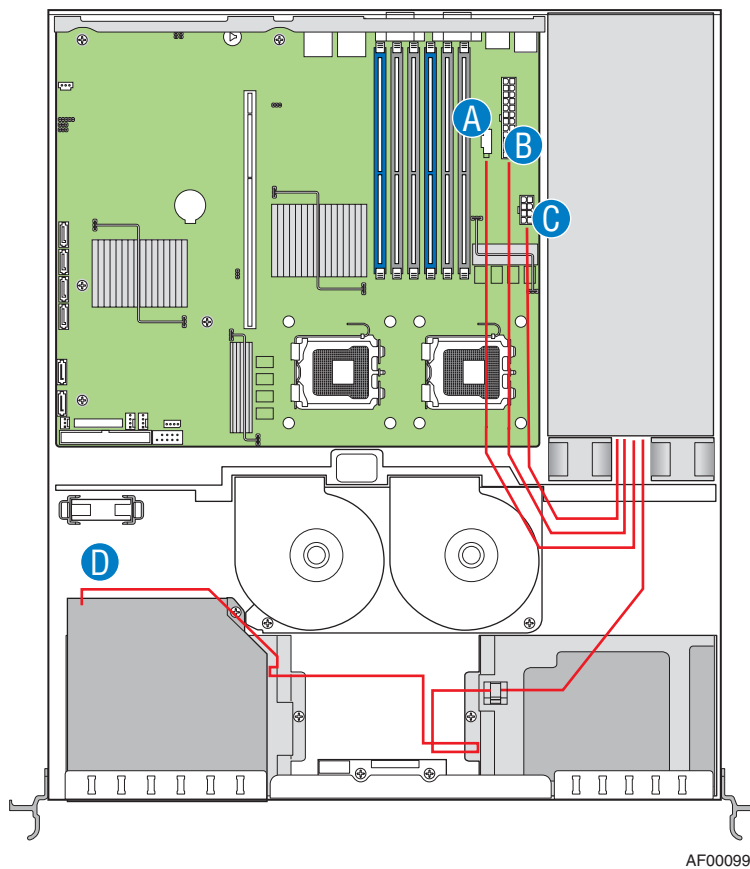

AF000998

Figure 76. Connecting Power Cables (SR1530CL/SR1530CLR)

8. Install the server system cover. For instructions, see “Installing the Server System Cover” on page 30.
9. Plug all peripheral devices and the AC power cable into the server.

Replacing the Power Supply (SR1530HCL/ SR1530HCLS and SR1530HCLR/SR1530HCLSR)

The power supply can be replaced if it fails or if one of the fans that is integrated into it fails. To replace the power supply, use the following instructions.

1. Observe the safety and ESD precautions at the beginning of this book. See [“Safety Information” on page iii](#).
2. Power down the server and unplug all peripheral devices and the AC power cable.
3. Remove the server system cover. For instructions, see [“Removing the Server System Cover”](#).
4. Remove the processor air duct. For instructions, see [“Removing the Processor Air Duct” on page 32](#).
5. Disconnect all power cables connected to the server board and peripherals:
 - A: Aux power signal
 - B: 2x12 main power connector
 - C: 2x4 power connector
 - D: Daisy-chain cable to optical drive power, if optical drive is installed.
 - E: 2x4 backplane power connector

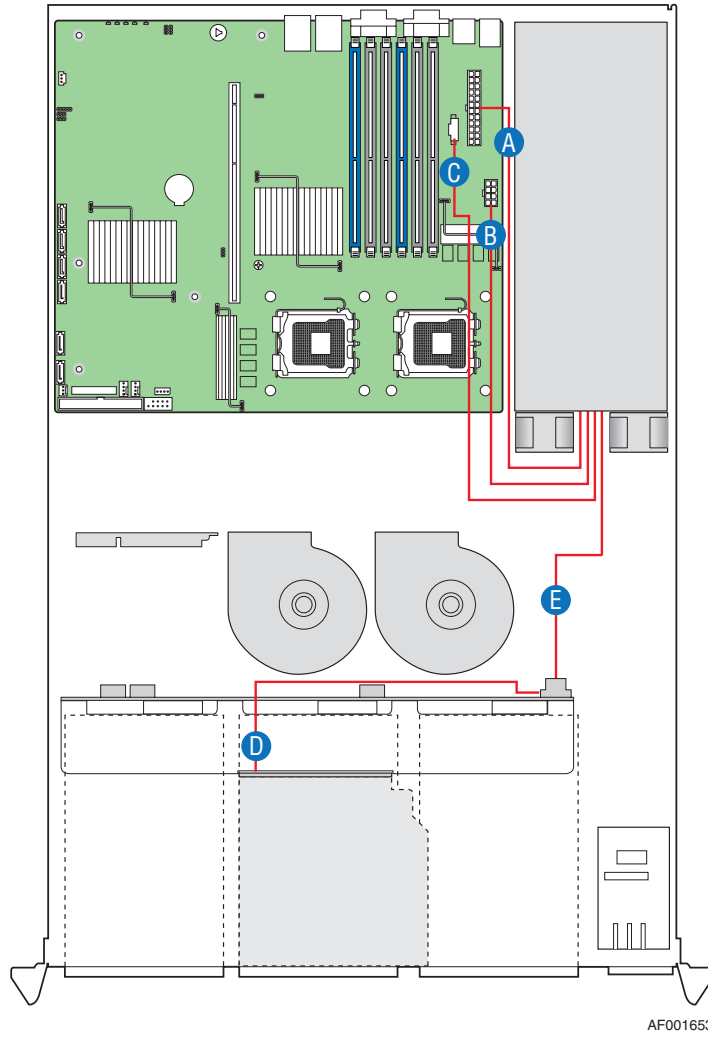

AF001653

Figure 77. Disconnecting Power Cables (SR1530HCL/SR1530HCLS and SR1530HCLR/SR1530HCLSR)

6. Ensure that the power cable has been disconnected (see letter “A” in the following figure).

Lift up slightly on the front of the power supply until it clears the foot at the bottom of the chassis (see letter “B”). Slide the power supply forward (see letter “C”) and then lift it from the chassis.

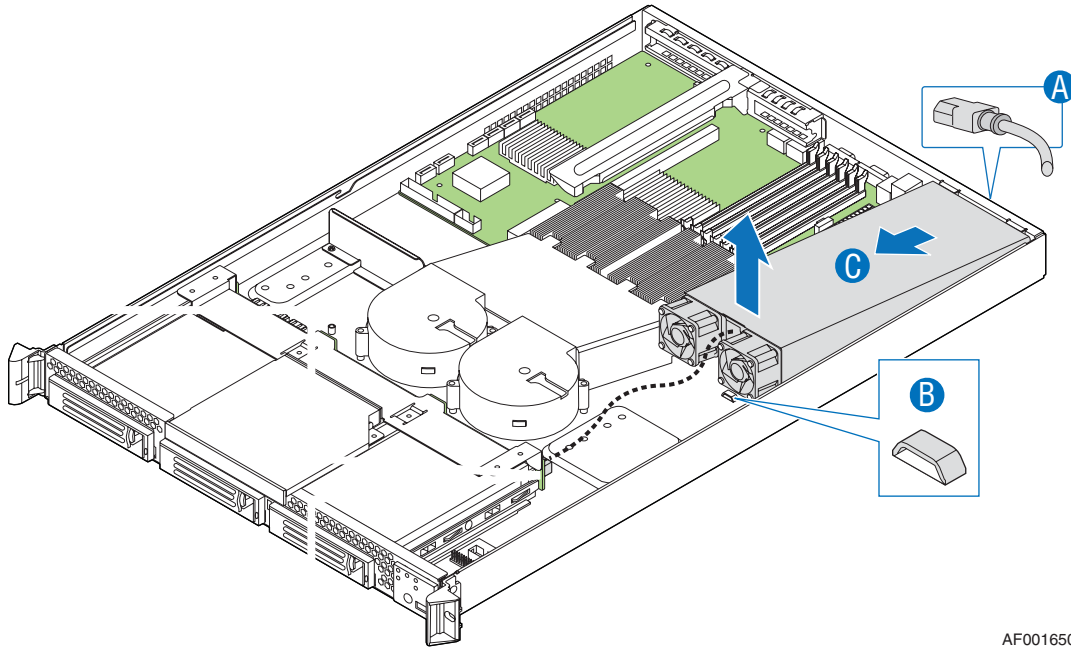

AF001650

Figure 78. Removing Power Supply from Server System (SR1530HCL/ SR1530HCLS and SR1530HCLR/SR1530HCLSR)

7. Insert the replacement power supply at an angle into the server system, sliding the power connector side in first to fit it through the cut-out area at the rear of the system (see letter “A” in the following figure).

Set the front of the power supply down pushing the power supply back so it fits behind the foot at the bottom of the chassis (see letter “B”).

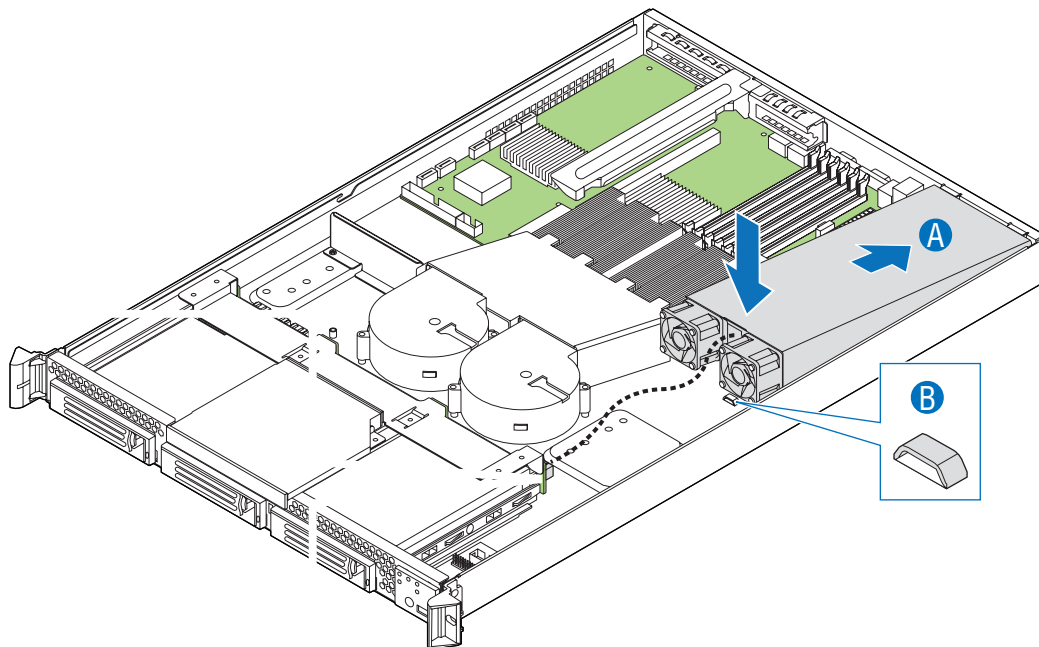

AF001651

**Figure 79. Installing Power Supply into Server System (SR1530HCL/
SR1530HCLS and SR1530HCLR/SR1530HCLSR)**

8. Connect the power supply cables to the server board and components.
 - A: Aux power signal
 - B: 2x12 main power connector
 - C: 2x4 power connector
 - D: Daisy-chain cable to optical drive power, if optical drive is installed. Use end connector on the cable.
 - E: 2x4 backplane connector

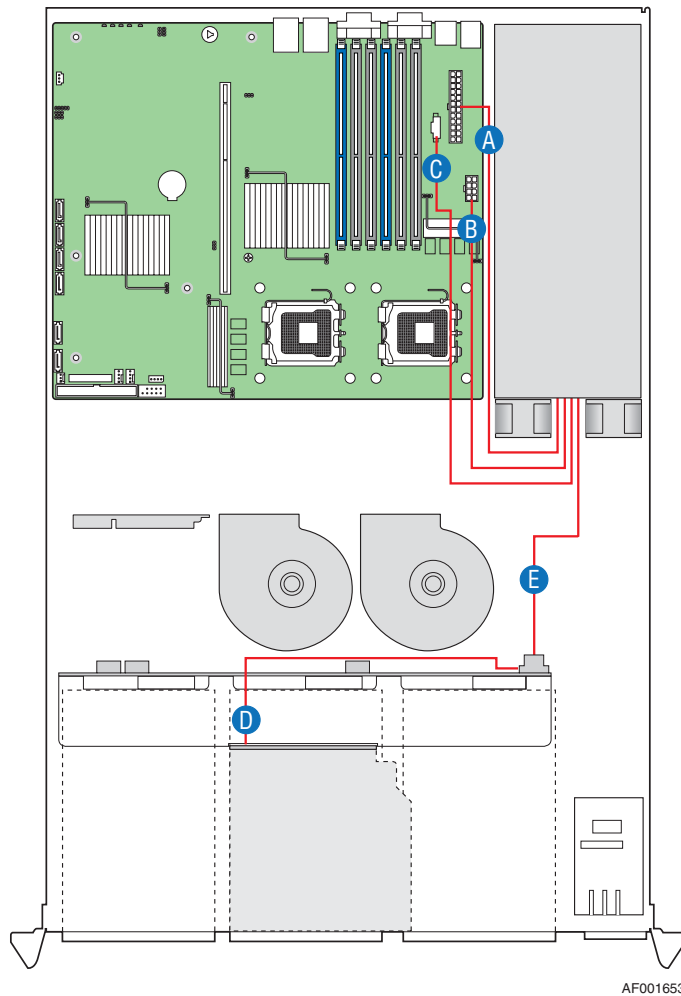

AF001653

Figure 80. Connecting Power Cables (SR1530HCL/SR1530HCLS and SR1530HCLR/SR1530HCLSR)

9. Install the processor air duct. For instructions, see [“Installing the Processor Air Duct” on page 33](#).
10. Install the server system cover. For instructions, see [“Installing the Server System Cover” on page 30](#).
11. Plug all peripheral devices and the AC power cable into the server.

Replacing the Front Panel Board (SR1530CL/ SR1530CLR)

Caution: The front panel board is NOT hot-swappable. Before removing or replacing the front panel board, you must first take the server out of service, turn off all peripheral devices connected to the system, turn off the system by pressing the power button, and unplug the AC power cord from the system or wall outlet.

Your server must be operated with a control panel installed.

1. Observe the safety and ESD precautions at the beginning of this book. See “[Safety Information](#)” on page iii.
2. Power down the server and unplug all peripheral devices and the AC power cable.
3. Remove the server system cover. For instructions, see “[Removing the Server System Cover](#)” on page 28.
4. Disconnect the power and data cables connected to HDD1, at the right side of the system. It is not necessary to remove the HDD1 drive.
5. Disconnect the front panel cable and the USB cable from the front panel board.
6. Remove the two screws that attach the front panel board to the server system. See letter “A” in the following figure. Save these screws. You will re-install them later.
7. Lift the front panel board from the system. See letter “B”.

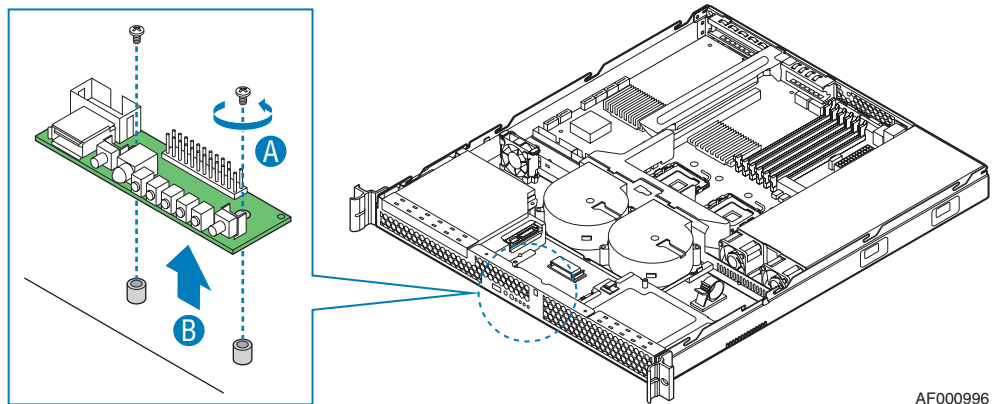

AF000996

Figure 81. Removing Front Panel Board from Server System (SR1530CL/ SR1530CLR)

8. Insert the replacement front panel board into the server system over the two standoffs. Press down gently until the board clicks into place.
9. Use the two screws you removed previously to attach the front panel board to the system.
10. Connect the USB cable and the front panel cable.
11. Connect the HDD1 power and data cables.

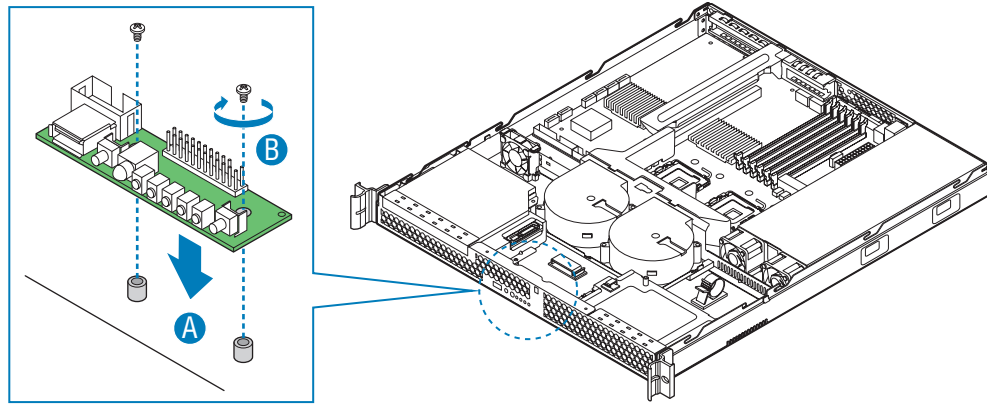

AF000997

Figure 82. Installing Front Panel Board in Server System (SR1530CL/ SR1530CLR)

12. Install the server system cover. For instructions, see [“Installing the Server System Cover”](#) on page 30.
13. Plug all peripheral devices and the AC power cable into the server.

Replacing the Front Panel Board (SR1530HCL/ SR1530HCLR)

Caution: The front panel board is NOT hot-swappable. Before removing or replacing the front panel board, you must first take the server out of service, turn off all peripheral devices connected to the system, turn off the system by pressing the power button, and unplug the AC power cord from the system or wall outlet.

Your server system must be operated with a front panel board installed.

1. Observe the safety and ESD precautions at the beginning of this book. See “[Safety Information](#)” on page iii.
2. Power down the server and unplug all peripheral devices and the AC power cable.
3. Remove the server system cover. For instructions, see “[Removing the Server System Cover](#)” on page 28.
4. Disconnect the front panel cable and the USB cable from the front panel board.
5. Remove the screw that attaches the existing front panel board to the server system. See letter “A” in the following figure. Save the screw. You will re-install it later.
6. Slide the existing front panel board back (see letter “B”) and lift the front panel board from the system (see letter “C”).

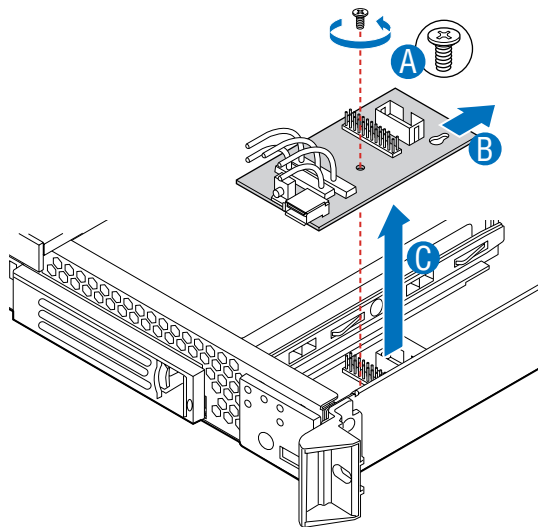

AF001591

Figure 83. Removing Front Panel Board from Server System (SR1530HCL/ SR1530HCLR)

7. Remove the light pipes from the existing front panel board (see letters “A” and “B” in the following figure).

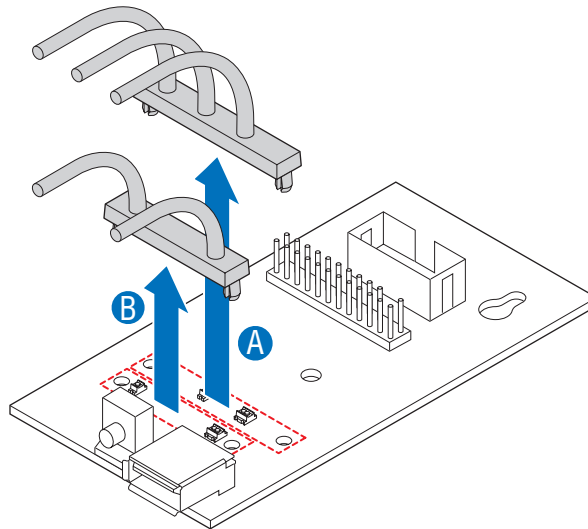

AF001645

Figure 84. Removing Light Pipes from Front Panel Board

8. Install the light pipes on the replacement front panel board.

Note: *It may be easier to install the replacement front panel board first, and then install the light pipes.*

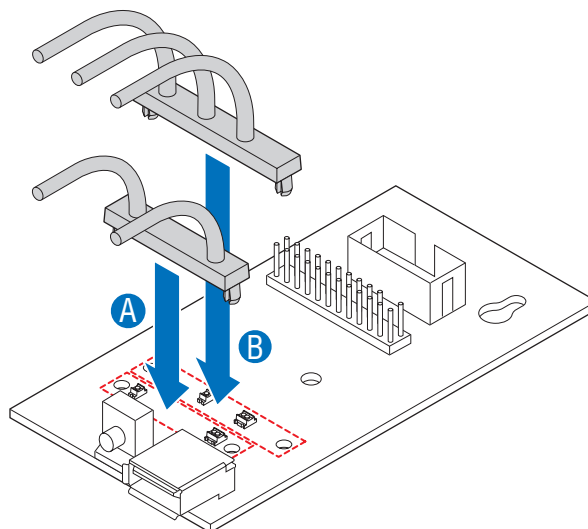

AF001646

Figure 85. Installing Light Pipes on Replacement Front Panel Board

9. Insert the replacement front panel board into the server system over the standoff (see letter “A” in the following figure) and slide the front panel board forward until the board clicks into place (see letter “B”). Use the screws you removed previously to attach the front panel board to the system (see letter “C”).

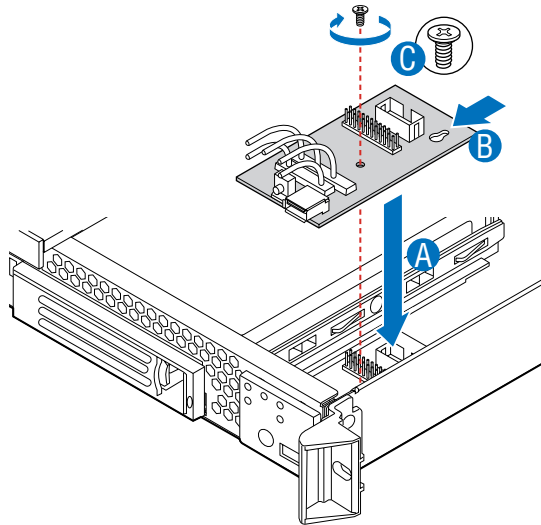

AF001592

Figure 86. Installing Front Panel Board into Server System (SR1530HCL/ SR1530HCLR)

10. Connect the USB cable if you removed it previously.
11. Connect the front panel cable.
12. Install the server system cover. For instructions, see [“Installing the Server System Cover”](#) on page 30.
13. Plug all peripheral devices and the AC power cable into the server.

Replacing a System Blower

Caution: The system blowers are *NOT* hot-swappable. Before removing or replacing a system blower, you must first take the server out of service, turn off all peripheral devices connected to the system, turn off the system by pressing the power button, and unplug the AC power cord from the system or wall outlet.

Note: The fans that are integrated into the power supply cannot be replaced separately. If one of the fans in the power supply fails, the power supply must be replaced.

The system blowers at the front of the server system can be individually replaced if one of them fails. If a fan in the power supply fails, the power supply must be replaced. Use the following steps to replace a system blower or the PCI cooling fan.

Replacing the System Blowers (SR1530CL/SR1530CLR)

1. Observe the safety and ESD precautions at the beginning of this book. See “[Safety Information](#)” on page iii.
2. Power down the server and unplug all peripheral devices and the AC power cable.
3. Remove the server system cover. For instructions, see “[Removing the Server System Cover](#)”.
4. Remove the processor air duct. For instructions, see “[Removing the Processor Air Duct](#)” on page 32
5. Disconnect the two system blower cables from the server board. See letters “A” and “B” in the following figure.

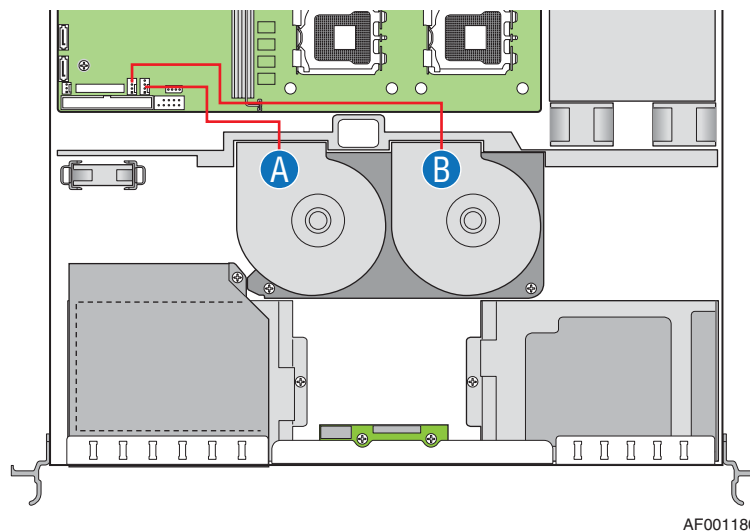
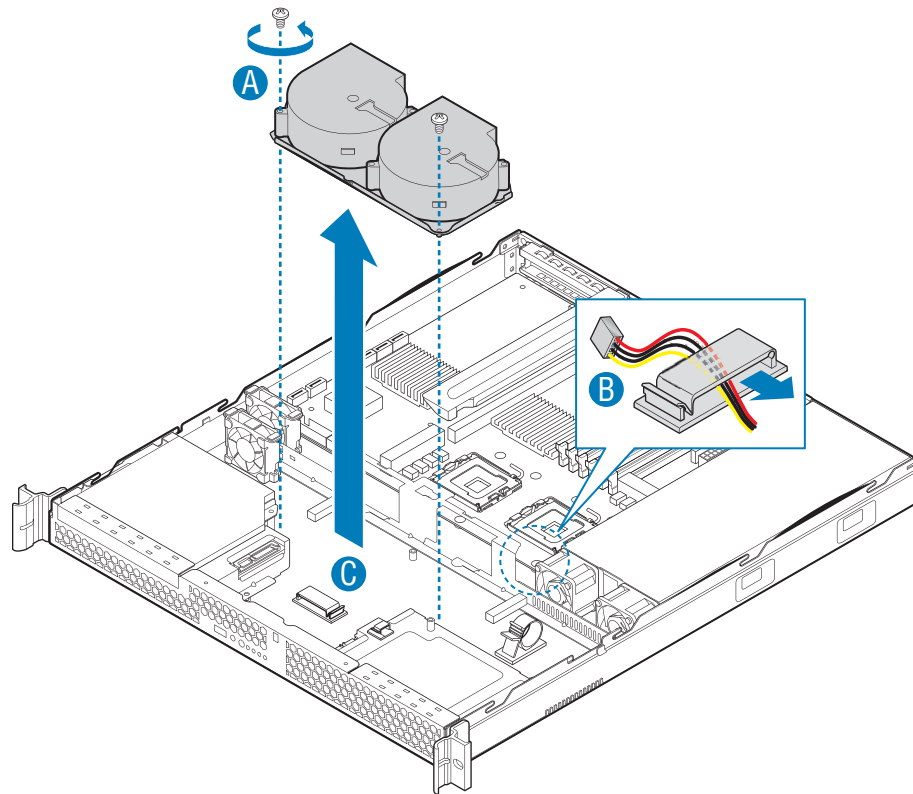

Figure 87. Disconnecting System Blower Cables (SR1530CL/SR1530CLR)

6. Remove the two screws that secure the blower bracket in place. Save these screws. You will re-install them later (see letter “A” in the following figure).

Remove the blower cable from beneath the clip at the front of the blower bracket (see letter “B”).

Lift the blower bracket from the server. Lift the bracket at an angle, the front of the bracket first, to clear the hard disk drive brackets (see letter “C”).



AF000990

Figure 88. Removing Blower Bracket with System Blowers from Server System (SR1530CL/SR1530CLR)

7. Turn the bracket over and remove the two screws that attach the failed blower to the blower bracket. Save these screws. You will reinstall them later. See letter “A” in the following figure). Lift the blower from the bracket (see letter “B”).

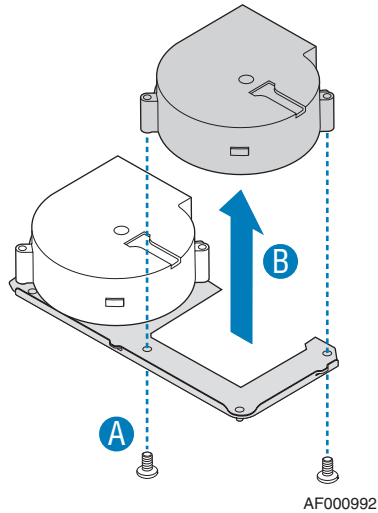

Figure 89. Removing System Blower from Blower Bracket (SR1530CL/ SR1530CLR)

8. Install the replacement blower onto the blower bracket, using the two screws you removed previously.
9. Set the blower assembly into the system. Insert the rear edge first and push the assembly slightly rearward to clear the hard disk drive brackets. Use caution to make sure you do not pinch any cables.
10. Route the cable from the blower at the right around the right side of the assembly and under the clip at the front of the blower bracket.
11. Secure the blower assembly to the system using the two screws you removed previously.

12. Connect the blower cables to the server board. See letters “A” and “B” in the following figure.

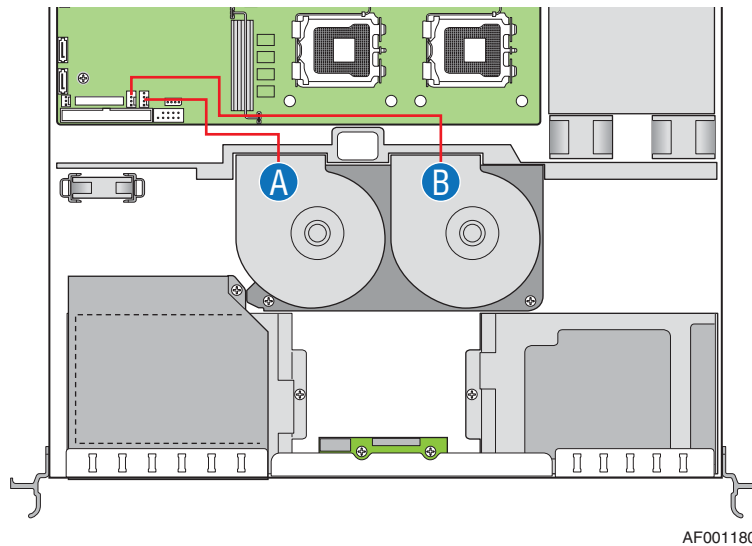

Figure 90. Connecting System Blower Cables (SR1530CL/SR1530CLR)

13. Install the processor air duct. For instructions, see [“Installing the Processor Air Duct”](#) on page 33.
14. Install the server system cover. For instructions, see [“Installing the Server System Cover”](#) on page 30.
15. Plug all peripheral devices and the AC power cable into the server.

Replacing a System Blower (SR1530HCL/SR1530HCLS and SR1530HCLR/SR1530HCLSR)

1. Observe the safety and ESD precautions at the beginning of this book. See [“Safety Information”](#) on page iii.
2. Power down the server and unplug all peripheral devices and the AC power cable.
3. Remove the server system cover. For instructions, see [“Removing the Server System Cover”](#).
4. Remove the processor air duct. For instructions, see [“Removing the Processor Air Duct”](#) on page 32

5. Disconnect the blower cable from the server board (see letter “A” in the following figure).

Remove the two screws attaching the system blower to the server system (see letter “B”).

Lift system blower out of the system.

Note: If you are replacing the right system blower (system blower #2), you will have to remove the left system blower (system blower #1) first because the cable for system blower #2 runs underneath system blower #1.

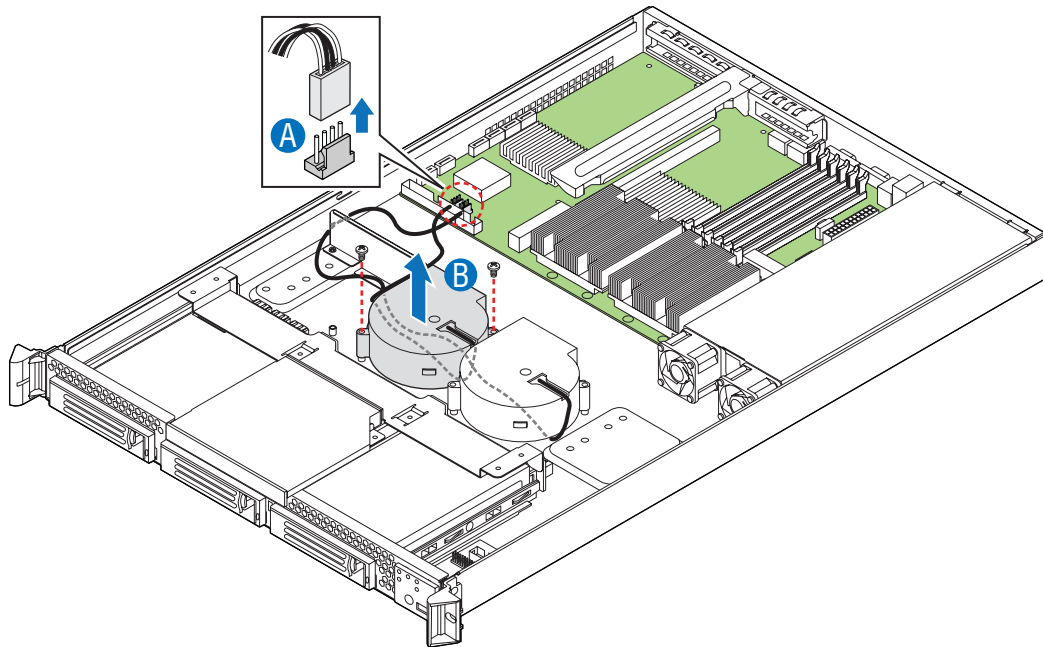

AF001648

**Figure 91. Removing System Blower from Server System (SR1530HCL/
SR1530HCLS and SR1530HCLR/SR1530HCLSR)**

6. Install the replacement blower, using the two screws you removed previously to secure the system blower to the server system (see letter “A” in the following figure).

Connect the blower cable to the server board (see letter “B”).

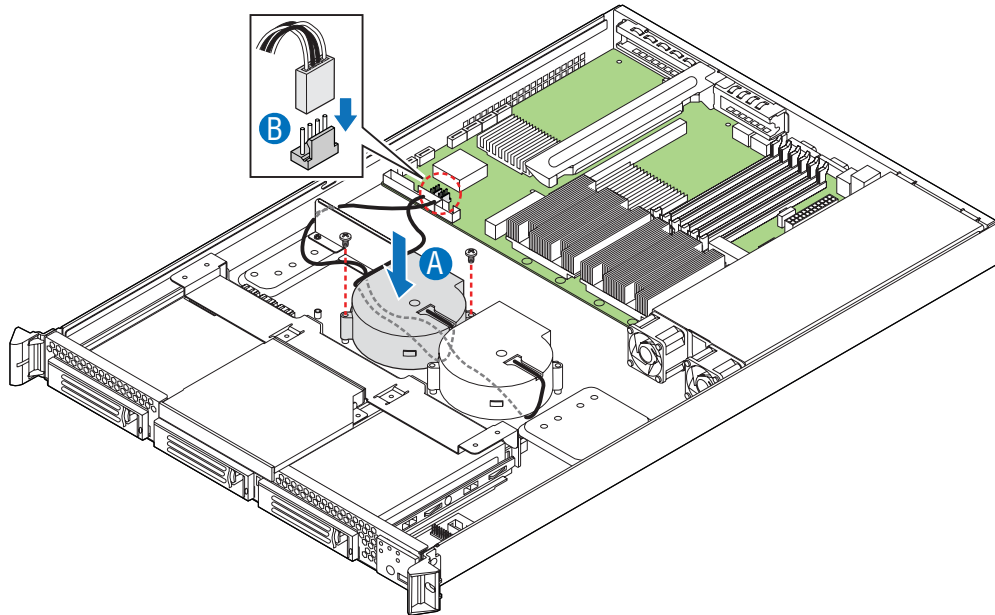

AF001649

Figure 92. Installing System Blower in Server System (SR1530HCL/ SR1530HCLS and SR1530HCLR/SR1530HCLSR)

7. Install the processor air duct. For instructions, see “Installing the Processor Air Duct” on page 33.
8. Install the server system cover. For instructions, see “Installing the Server System Cover” on page 30.
9. Plug all peripheral devices and the AC power cable into the server.

Replacing the PCI Cooling Fan (SR1530CL/SR1530CLR)

Note: These instructions only apply to the Intel® Server System SR1530CL / SR1530CLR. The Intel® Server System SR1530HCL / SR1530HCLS and the Intel® Server System SR1530HCLR / SR1530HCLSR do not have a PCI cooling fan; they have a PCI cooling baffle.

1. Observe the safety and ESD precautions at the beginning of this book. See “Safety Information” on page iii.
2. Power down the server and unplug all peripheral devices and the AC power cable.
3. Remove the server system cover. For instructions, see “Removing the Server System Cover”.

4. Disconnect the fan cable from the server board. See letter “A” in the following figure.

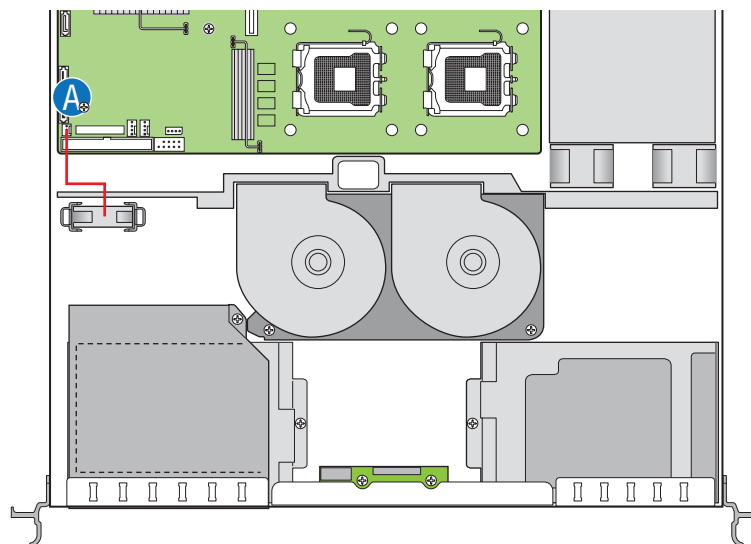

AF001181

Figure 93. Disconnecting the PCI Cooling Fan (SR1530CL/SR1530CLR)

5. Lift the PCI cooling fan from the system.

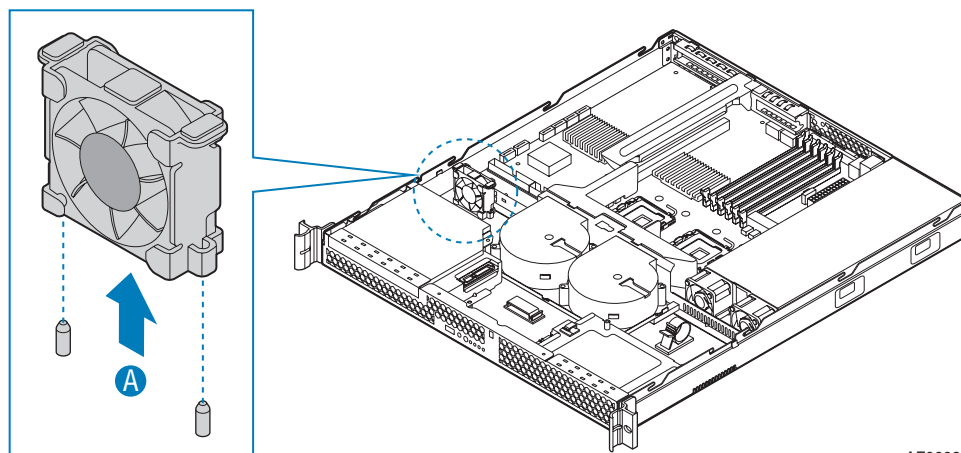

AF000988

Figure 94. Removing the PCI Cooling Fan (SR1530CL/SR1530CLR)

6. Set the replacement PCI cooling fan into place. The label on the fan must face the rear of the system.
7. Connect the fan cable to the server board. See letter “A” in [Figure 93](#).
8. Install the server system cover. For instructions, see [“Installing the Server System Cover”](#).
9. Plug all peripheral devices and the AC power cable into the server.

Installing and Removing the Rack Handles

Installing the Rack Handles

1. Observe the safety and ESD precautions at the beginning of this book. See [“Safety Information”](#) on page iii.
2. Power down the server and unplug all peripheral devices and the AC power cable.
3. Remove the front bezel if it is installed. For instructions, see [“Removing the Front Bezel”](#) on page 26.
4. Attach the rack handle to the server system with two screws as shown in the following figure.

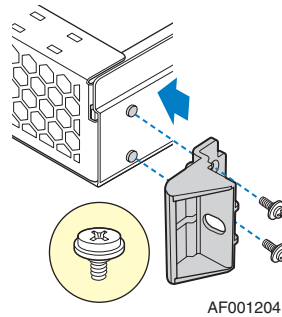

Figure 95. Installing the Rack Handle

5. Repeat step 4 on the opposite side of the server.
6. Optional: Install the front bezel, if desired. For instructions, see [“Installing the Front Bezel”](#) on page 27.
7. Plug all peripheral devices and the AC power cable into the server.

Removing the Rack Handles

1. Observe the safety and ESD precautions at the beginning of this book. See [“Safety Information” on page iii](#).
2. Power down the server and unplug all peripheral devices and the AC power cable.
3. Remove the front bezel if it is installed. For instructions, see [“Removing the Front Bezel” on page 26](#).
4. Remove the two screws holding the rack handle in place, and remove the rack handle from the server system as shown in the figure below.

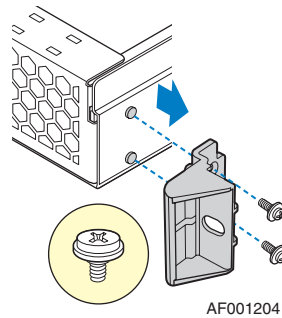

Figure 96. Removing the Rack Handle

5. Repeat step 4 on the opposite side of the server.
6. Optional: Install the front bezel, if desired. For instructions, see [“Installing the Front Bezel” on page 27](#).
7. Plug all peripheral devices and the AC power cable into the server.

Appendix A: Technical Reference

Cable Routing

When you add or remove components from your server system, make sure your cables are routed correctly before reinstalling the server system cover. Use caution to make sure no cables or wires are pinched and that the airflow from the fans is not blocked. Use the figures below to determine the correct cable routing.

For readability, two figures are included below to show the cable routing. Make sure all necessary power and data cables are connected and routed as shown. Dashed lines in the drawings indicate a location where a cable is routed beneath a component and each connector end is labeled with the same letter. For example, the PCI cooling fan cable is labeled with the letter “E” both where it connects to the server board and at the PCI cooling fan itself.

Power Cable Routing (SR1530CL/SR1530CLR)

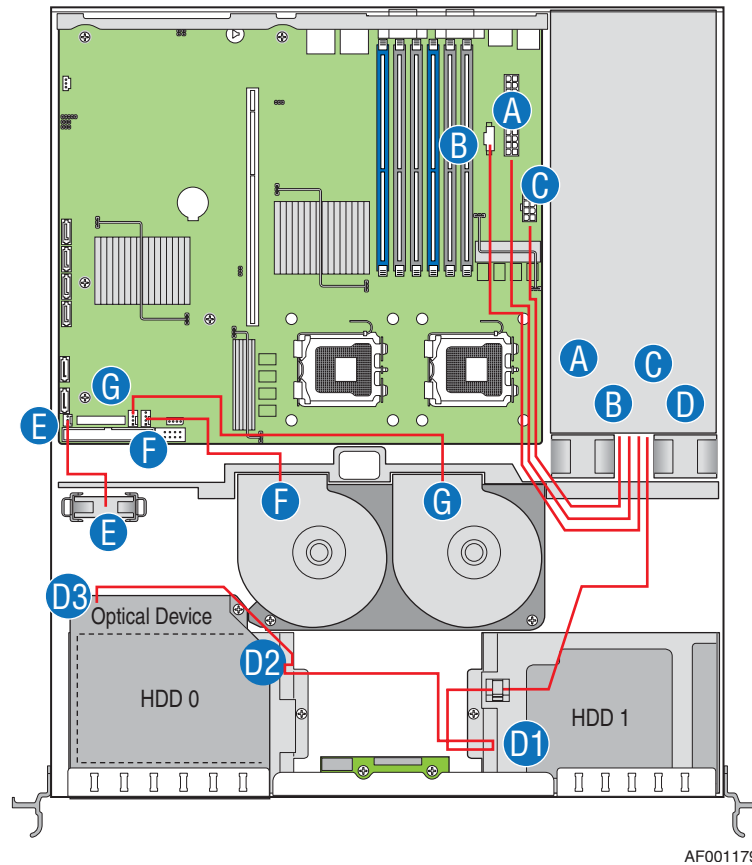

| | |
|--|------------------------|
| A. Main power | E. PCI cooling fan |
| B. Aux power signal | F. Left system blower |
| C. Processor power | G. Right system blower |
| D. Drive power daisy cable <ul style="list-style-type: none"> – F1: connector closest to power supply to HDD1 – F2: center connector to HDD0 – F3: end connector to optical drive | |

Figure 97. Power Cable Routing (SR1530CL/SR1530CLR)

Note: The power cable to the two hard drives and the optical drive is a single daisy chain cable. To make the diagram above more clear, where the connectors attach to components, the labels “D1”, “D2”, and “D3” are used. The end at the power supply itself is labeled “D”.

Power Cable Routing (SR1530HCL/SR1530HCLS and SR1530HCLR/SR1530HCLSR)

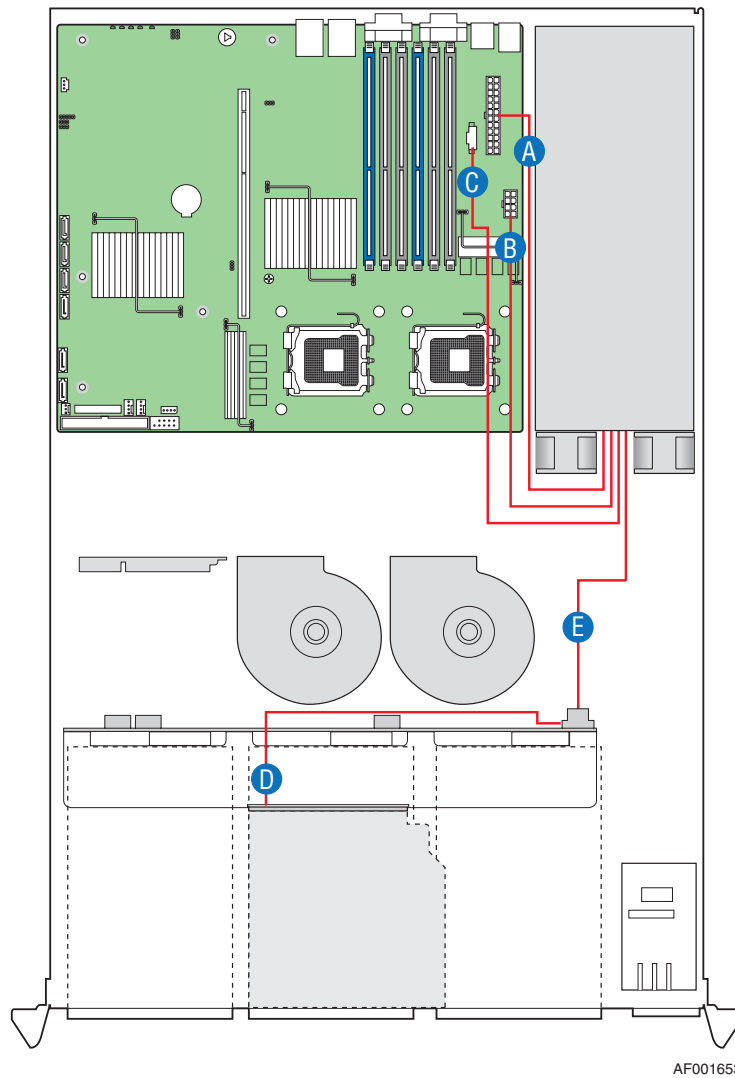

| | |
|---|---------------------------|
| A. Main power | E. System blower #1 |
| B. Processor power | F. System blower #2 |
| C. Backplane power | G. Auxillary power signal |
| D. Drive power daisy cable: — F3: end connector to optical drive | |

Figure 98. Power Cable Routing (SR1530HCL/SR1530HCLS and SR1530HCLR/SR1530HCLSR)

Data Cable Routing (SR1530CL/SR1530CLR)

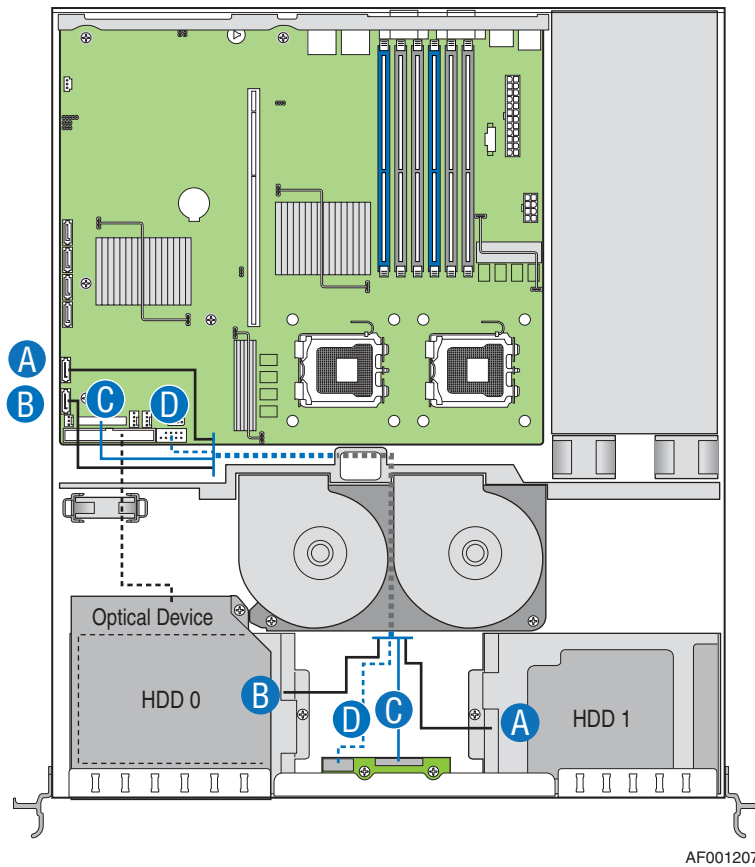

AF001207

| | |
|-------------------|------------------------|
| A. SATA 1 to HDD1 | C. Front control panel |
| B. SATA 0 to HDD0 | D. Front panel USB |

Figure 99. Data Cable Routing (SR1530CL/SR1530CLR)

Data Cable Routing (SR1530HCL/SR1530HCLS and SR1530HCLR/SR1530HCLSR)

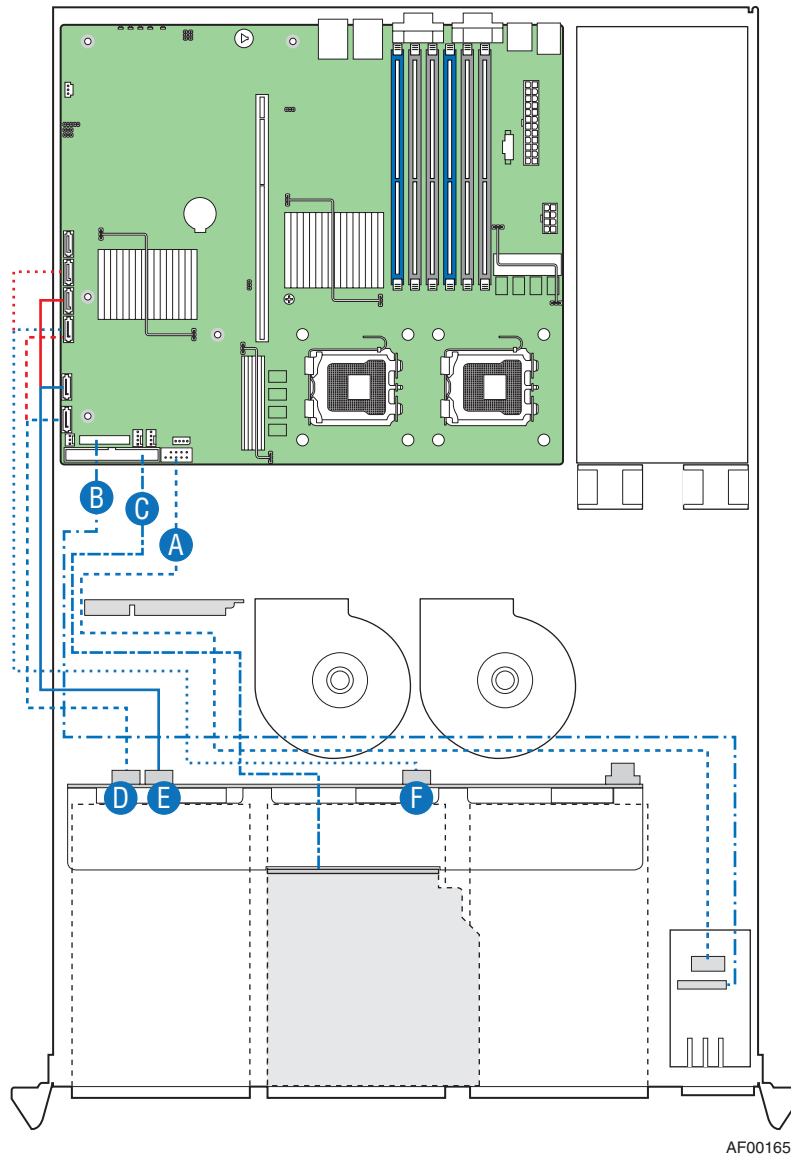

| | |
|---------------------------|-----------------------|
| A. Front Panel USB | D. HDD0 to SATA0/SAS0 |
| B. Front Control Panel | E. HDD1 to SATA1/SAS1 |
| C. Optical Slimline Drive | F. HDD1 to SATA2/SAS2 |

Figure 100. Data Cable Routing (SR1530HCL/SR1530HCLS and SR1530HCLR/SR1530HCLSR)

400-W Single Power Supply Input Voltages

- 100 - 127 volts at 50 / 60 Hz; 5.7 amps maximum
- 200 - 240 volts at 50 / 60 Hz; 2.8 amps maximum

400-W Single Power Supply Output Voltages

The following table lists the total wattage available from the power subsystem for each voltage. Ensure that your loads do not exceed the combined total wattage of 400 Watts.

Table 4. Power Supply Output Capability

| Voltage | Maximum Current |
|--------------|-----------------|
| +3.3 V | 15 amps |
| +5.0 V | 10 amps |
| +5 V Standby | 3 amps |
| +12.0 | 32 amps |
| -12.0 V | 0.5 amps |

Warning: Do not exceed a combined power output of 90 Watts for the +5 V and +3.3 V outputs. Exceeding a combined 90 Watts will overload the power subsystem and may cause the power supplies to overheat and malfunction.

System Environmental Specifications

Table 5. System Environmental Specifications

| | |
|-------------------------------|--|
| Temperature | |
| Non-operating | -40 ° to 70 °C. |
| Operating | 10 ° to 35 °C, with the maximum rate of change not to exceed 10 ° C per hour |
| Humidity | |
| Non-operating | 90% relative humidity, non-condensing at 35 °C. |
| Shock | |
| Operating | 2.0 g, 11 msec, 1/2 sine |
| Packaged | Operational after an 24-inch free fall. |
| Acoustic noise | 7 Bels in sound power for a typical office ambient temperature (65-75 °F). Your selection of peripherals may change the noise level. |
| Electrostatic discharge (ESD) | Tested to 15 kilovolts (kV); no component damage. |

Appendix B: Troubleshooting

This chapter helps you identify and solve problems that might occur while you are using the system.

For any issue, first ensure you are using the latest firmware and files. Firmware upgrades include updates for BIOS, the Baseboard Management Controller (BMC), and the hot-swap controller (HSC). See [“Server System References” on page ix](#) for a link to the software updates. In addition to the server firmware and files, also update any drivers used for components you have installed in your system, such as video drivers, network drivers, and SATA drivers.

Intel provides a package called the "Platform Confidence Test" that may help with your diagnostics. See [“Server System References” on page ix](#) for a link to this software.

If you are unable to resolve your server problems on your own, see [“Getting Help” on page 117](#) for assistance.

Resetting the System

Before going through in-depth troubleshooting, attempt first to reset your system using one of the methods below.

Table 6. Resetting the System

| To do this | Press |
|--|---|
| Soft boot reset to clear the system memory and reload the operating system | <Ctrl+Alt+Del> |
| Cold boot reset. Turn the system power off and then on. This clears system memory, restarts POST, reloads the operating system, and halts power to all peripherals | Power off/on button |
| Reset the BMC and get it back to a stable state | Remove AC power from the server for one minute |
| Power down the system | Press and hold the power button for four seconds. This will force the system to power down. To power back up, press the power button again. |

Problems following Initial System Installation

Problems that occur at initial system startup are usually caused by an incorrect installation or configuration. Hardware failure is a less frequent cause. If the problem you are experiencing is with a specific software application, see [“Problems with Newly Installed Application Software”](#) on page 112.

First Steps Checklist

- Is AC power available at the wall outlet?
- Are the power supplies plugged in? Check the AC cable(s) on the back of the chassis and at the AC source.
- Are all cables correctly connected and secured?
- Are the processors fully seated in their sockets on the server board?
- Are all standoffs in the proper location and not touching any components, causing a potential short?
- Are all add-in PCI boards fully seated in their slots on the server board?
- Are all jumper settings on the server board correct?
- Are all jumper and switch settings on add-in boards and peripheral devices correct? To check these settings, refer to the manufacturer's documentation that comes with them. If applicable, ensure that there are no conflicts—for example, two add-in boards sharing the same interrupt.
- Are all peripheral devices installed correctly?
- If the system has a hard disk drive, is it properly formatted or configured?
- Are all device drivers properly installed?
- Are the configuration settings made in Setup correct?
- Is the operating system properly loaded? See the operating system documentation.
- Did you press the system power on/off switch on the front panel to turn the server on (power on light should be lit)?
- Is the system power cord properly connected to the system and plugged into a NEMA 5 15R outlet for 100-120V or a NEMA 6-15R outlet for 200-240V ?
- Are all integrated components from the tested components lists? Check the tested memory, and chassis lists, as well as the supported hardware and operating system list. See [“Server System References”](#) on page ix for links to the tested component lists.

Hardware Diagnostic Testing

This section provides a more detailed approach to identifying a hardware problem and locating its source.

Caution: *Turn off devices before disconnecting cables: Before disconnecting any peripheral cables from the system, turn off the system and any external peripheral devices. Failure to do so can cause permanent damage to the system and/or the peripheral devices.*

1. Turn off the system and all external peripheral devices. Disconnect each device from the system, except for the keyboard and the video monitor.
2. Make sure the system power cord is plugged into a properly grounded AC outlet.
3. Make sure your video display monitor and keyboard are correctly connected to the system. Turn on the video monitor. Set its brightness and contrast controls to at least two thirds of their maximum ranges (see the documentation supplied with your video display monitor).
4. If the operating system normally loads from the hard disk drive, make sure there is no CD-ROM / DVD disk in the optical drive.
5. If the power LED does light, attempt to boot from a CD-ROM disk.
6. Turn on the system. If the power LED does not light, see [“Power Light Does Not Light” on page 108](#).

Verifying Proper Operation of Key System Lights

As POST determines the system configuration, it tests for the presence of each mass storage device installed in the system. As each device is checked, its activity light should turn on briefly. Check for the following:

- Does the drive activity light turn on briefly? If not, see [“Drive Activity Light Does Not Light” on page 110](#).

Confirming Loading of the Operating System

Once the system boots up, the operating system prompt appears on the screen. The prompt varies according to the operating system. If the operating system prompt does not appear, see [“No Characters Appear on Screen” on page 109](#).

Specific Problems and Corrective Actions

This section provides possible solutions for these specific problems:

- Power light does not light.
- No characters appear on screen.
- Characters on the screen appear distorted or incorrect.
- System cooling fans do not rotate.
- Diskette drive activity light does not light.
- Hard disk drive activity light does not light.
- CD-ROM drive activity light does not light.
- There are problems with application software.
- The bootable CD-ROM is not detected.

Try the solutions below in the order given. If you cannot correct the problem, contact your service representative or authorized dealer for help.

Power Light Does Not Light

Check the following:

- Did you press the power-on button?
- Is the system operating normally? If so, the power LED might be defective or the connection from the control panel to the server board might be loose.
- Have you securely plugged the server AC power cord into the power supply?
- Some ATX power supplies have a power switch on the back of the power supply, next to the fan. If your system has one, is it turned on?
- Remove all add-in cards and see if the system boots. If successful, add the cards back in one at a time with a reboot between each addition.
- Make sure the memory DIMMs comply with the system requirements.
- Make sure the memory DIMMs have been populated according to the system requirements.
- Remove the memory DIMMs and re-seat them.
- Make sure the processor(s) comply with the system requirements.
- Make sure the processor(s) have been populated according to the system requirements.
- Remove the processor(s) and re-seat them.
- Make sure the chassis standoffs are installed only below mounting holes. Misplaced standoffs can contact the pins on the bottom of the server board and cause a short.

No Characters Appear on Screen

Check the following:

- Is the keyboard functioning? Test it by turning the "Num Lock" function on and off to make sure the Num Lock light is functioning.
- Is the video monitor plugged in and turned on? If you are using a switch box, is it switched to the correct system?
- Are the brightness and contrast controls on the video monitor properly adjusted?
- Is the video monitor signal cable properly installed?
- Does this video monitor work correctly if plugged into a different system?
- Is the onboard video controller enabled in the BIOS?
- Remove all add-in cards and see if the video returns. If successful, add the cards back in one at a time with a reboot between each addition.
- Make sure the memory DIMMs comply with the system requirements.
- Make sure the memory DIMMs have been populated according to the system requirements.
- Remove the memory DIMMs and re-seat them.
- Make sure the processor(s) comply with the system requirements.
- Make sure the processor(s) have been populated according to the system requirements.
- Remove the processor(s) and re-seat them.

If you are using an add-in video controller board, do the following:

1. Verify that the video works using the onboard video controller.
2. Verify that the video controller board is fully seated in the server board connector.
3. Reboot the system for changes to take effect.
4. If there are still no characters on the screen after you reboot the system and POST emits a beep code, write down the beep code you hear. This information is useful for your service representative.
5. If you do not receive a beep code and characters do not appear, the video display monitor or video controller may have failed. Contact your service representative or authorized dealer for help.

Characters Are Distorted or Incorrect

Check the following:

- Are the brightness and contrast controls properly adjusted on the video monitor? See the manufacturer's documentation.
- Are the video monitor's signal and power cables properly installed?
- Does this video monitor work correctly if plugged into a different system?

System Cooling Fans Do Not Rotate Properly

If the system cooling fans are not operating properly, it is an indication of possible system component failure.

Check the following:

- Is the power-on light lit? If not, see [“Power Light Does Not Light” on page 108](#).
- If your system has LED lights for the fans, is one or more of these LEDs lit?
- Are any other control panel LEDs lit?
- Have any of the fan motors stopped? Use the server management subsystem to check the fan status.
- Have your fans speeded up in response to an overheating situation?
- Have your fans speeded up in response to a fan that has failed?
- Are the fan power connectors properly connected to the server board?
- Is the cable from the control panel board connected to the both the control panel board and to the server board?
- Are the power supply cables properly connected to the server board?
- Are there any shorted wires caused by pinched-cables or have power connector plugs been forced into power connector sockets the wrong way?

Drive Activity Light Does Not Light

Check the following:

- Are the drive's power and signal cables properly installed?
- Are all relevant switches and jumpers on the drive set correctly?
- Is the drive properly configured?
- Is the drive activity light always on? If so, the signal cable may be plugged in incorrectly.

CD-ROM Drive or DVD-ROM Drive Activity Light Does Not Light

Check the following:

- Are the CD-ROM/DVD-ROM drive's power and signal cables properly installed?
- Are all relevant switches and jumpers on the drive set correctly?
- Is the drive properly configured?

Cannot Connect to a Server

- Make sure the network cable is securely attached to the correct connector at the system back panel.
- Try a different network cable.
- Make sure you are using the correct and the current drivers. See [“Server System References” on page ix](#) for a link to the current drivers.
- Make sure the driver is loaded and the protocols are bound.
- Make sure the hub port is configured for the same duplex mode as the network controller.
- Make sure the correct networking software is installed.
- If you are directly connecting two servers (without a hub), you will need a crossover cable.
- Check the network controller LEDs next to the NIC connectors.

Problems with Network

The server hangs when the drivers are loaded

- Certain drivers may require interrupts that are not shared with other PCI drivers. For these drivers, it may be necessary to alter settings so that interrupts are not shared. See the documentation that came with your PCI card(s) for information on changing interrupts.

Diagnostics pass but the connection fails

- Make sure the network cable is securely attached.
- Make sure you specify the correct frame type in your NET.CFG file.
- The controller stopped working when an add-in adapter was installed.
- Make sure the cable is connected to the port from the onboard network controller.
- Make sure your BIOS is current. See [“Server System References” on page ix](#) for a link to the current version.

- Make sure the other adapter supports shared interrupts. Make sure your operating system supports shared interrupts.
- Try reseating the add-in adapter.

The add-in adapter stopped working without apparent cause

- Reseat the adapter.
- Put the adapter in a different slot.
- The network driver files may be corrupt or deleted. Delete and then reinstall the drivers.
- Run diagnostics.

System Boots when Installing PCI Card

System Management features require full-time "standby" power. This means some parts of the system have power going to them whenever the power cord is plugged in, even if you have turned the system power off with the power button on the front panel. If you install a PCI card with the AC power cord plugged in, a signal may be sent to command the system to boot. Before installing a PCI card, you should always:

- Turn off the server power by using the power button on the front of the system.
- Unplug the AC power cord(s) from the server.

Problems with Newly Installed Application Software

Problems that occur when you run new application software are usually related to the software, not the server hardware. Faulty equipment is unlikely, especially if other software runs correctly.

Check the following:

- Make sure the system meets the minimum hardware requirements for the software. See the software documentation.
- Make sure the software is properly installed and configured for the system. See the software documentation.
- Use only an authorized copy. Unauthorized copies often do not work.
- If you are running the software from a CD-ROM or DVD-ROM, try a different disk.
- Make sure the correct device drivers installed.

If the problems persist, contact the software vendor's customer service representative.

Problems with Application Software that Ran Correctly Earlier

Problems that occur after the system hardware and software have been running correctly sometimes indicate equipment failure. However, they can also be caused by file corruption or changes to the software configuration.

Check the following:

- If you are running the software from a CD-ROM or DVD-ROM, try a different disk.
- Check your system for a virus infection.
- Uninstall and reinstall the software. Make sure all necessary files are installed.
- If the problems are intermittent, there may be a loose cable, dirt in the keyboard (if keyboard input is incorrect), a marginal power supply, or other random component failures.
- If you suspect that a transient voltage spike, power outage, or brownout might have occurred, reload the software and try running it again. Symptoms of voltage spikes include a flickering video display, unexpected system reboots, and the system not responding to user commands.

***Note:** Random errors in data files: If you are getting random errors in your data files, they may be getting corrupted by voltage spikes on your power line. If you are experiencing any of the above symptoms that might indicate voltage spikes on the power line, you may want to install a surge suppressor between the power outlet and the system power cord.*

Devices are not Recognized under Device Manager (Microsoft Windows* Operating System)

The Microsoft Windows* operating systems do not include all of the drivers for the Intel[®] chipsets, onboard NICs, and other components. See [“Server System References” on page ix](#) for a link to the current drivers and chipset files.

Hard Drive(s) are not Recognized

Check the following:

- Make sure the drive is not disabled in BIOS Setup.
- Make sure the drive is connected correctly and that is plugged into the power supply.
- Make sure the drive is compatible. See [“Server System References” on page ix](#) for a link to the tested drives.
- Make sure you have not exceeded the power budget for the server. See [“Server System References” on page ix](#) for a link to software to check your power budget.
- If using ATA drives, verify that the master/slave settings are set correctly. See your drive documentation for details on setting the master/slave settings.

- If using a RAID configuration with SATA drives, make sure the RAID card is installed correctly.

Bootable CD-ROM Disk Is Not Detected

Check the following:

- Make sure the BIOS is configured to allow the CD-ROM to be the first bootable device.

LED Information

The Intel® Server System SR1530CL / SR1530HCL / SR1530HCLS includes LEDs that can aid in troubleshooting your system. A table of these LEDs with a description of their use is listed below.

Table 7. LED Information

| LED Name | Function | Location | LED Color | Notes |
|---------------|---|------------------------------------|----------------|---|
| Power | Indicates system power is on or off | Front control panel | Green | Off = Power is off or in sleep state S4 Blink = Sleep S1 On = Power is on |
| HD Activity | Visible indication of hard drive activity | Front control panel | Green | Blink = Hard drive access |
| System Status | Visible fault warning | Front control panel and back panel | Green or Amber | Green = no fault Green blinking = degraded condition Amber blinking = non-critical error Amber = critical or non-recoverable error See Table 8. |
| NIC1 Activity | Visible indication of LAN #1 activity | Front control panel | Green | On = LAN link, no access Blink = LAN access Off = Idle |
| NIC2 Activity | Visible indication of LAN #2 activity | Front control panel | Green | On = LAN link, no access Blink = LAN access Off = Idle |

System Status LED

The system status LED uses colors and blink codes as outlined in the following table.

Table 8. System Status LED Color and Blink Codes

| Color / Blink Pattern | Critical Level | Description |
|-----------------------|-----------------------------------|---|
| Off | No issue | System is not ready |
| Green on | No issue | System is booted and ready to use |
| Green blink | System degraded | <p>The system is not likely to fail soon, but a problem occurred that must be addressed. One of the following problems may have occurred:</p> <ul style="list-style-type: none"> • More than one DIMM is installed, but system cannot use all of the installed memory. • Correctable memory errors have passed the threshold of 10. Memory sparing is enabled and the system is migrating to a spare DIMM. DIMM redundancy is lost because of this. • The system is in a mirrored configuration and has lost memory redundancy. • A PCI-Express link error has occurred. • A processor has failed or is disabled. • A fan failed. • A temperature or voltage threshold has been crossed. |
| Amber blink | Non-critical problem | <p>The system is likely to fail. One of the following problems may have occurred</p> <ul style="list-style-type: none"> • A critical voltage threshold has been crossed. • The minimum number of fans needed to cool the system are not available or not working. • In non-sparing and non-mirroring mode the threshold of ten correctable errors has been crossed within an allotted time window. |
| Amber on | Critical, non-recoverable problem | <p>Fatal alarm - system has failed or shutdown</p> <ul style="list-style-type: none"> • Only one DIMM is installed and that DIMM has failed, or multiple DIMMs are installed and none is usable. • An uncorrectable run-time memory uncorrectable error occurred and the system is in a non-redundant mode. • The IERR signal has been asserted. • Processor 1 is missing. • Temperature critical threshold crossed (CPU ThermTrip, memory TempHi) • Power fault • Processor configuration error, such as a processor stepping mismatch) |

BIOS POST Beep Codes

The table below lists the POST error beep codes. Prior to system video initialization, the BIOS uses these beep codes to inform users of error conditions. Please note that not all error conditions are supported by BIOS beep codes.

Table 9. POST Error Beep Codes

| Number of Beeps | Reason for Beeps and Action to Take |
|------------------------|---|
| 1, 2, or 3 | Memory error. Reseat the memory or replace the DIMMs with known good modules. |
| 4 - 7 or 9 - 11 | Fatal error indicating a possible serious system problem. Remove all add-in cards and re-start the system. If the error still occurs, contact your system manufacturer. If the beep codes are not generated after the add-in cards are removed, insert the cards one at a time, booting the system between each card addition, until the beeps again occur to reveal the malfunctioning card. |
| 8 | Replace or reseat the system video add-in card. If on-board video is being used, the server board may be faulty. |

In addition to the beep codes above, additional beep codes are provided if an Intel[®] Remote Management Module is installed. The Intel[®] Remote Management Module provides the following additional beep codes.

Table 10. Error Beep Codes Generated by Intel[®] Remote Management Module

| Number of Beeps | Reason for Beeps and Action to Take |
|------------------------|--|
| 1 | Control panel CMOS clear has been initiated. |
| 1-5-1-1 | Processor failure. Reseat or replace the failed processor. |
| 1-5-2-1 | No processor is installed or the CPU 1 socket is empty. Reseat or replace the failed processor. |
| 1-5-2-3 | Processor configuration error or CPU 1 socket is empty. Reseat or replace the failed processor. In a two-processor system, make sure the processors are identical. |
| 1-5-2-4 | Front-side bus select configuration error. |
| 1-5-4-2 | DC power unexpectedly lost. |
| 1-5-4-3 | Chipset control failure. |
| 1-5-4-4 | Power control failure. |

Appendix C: Getting Help

World Wide Web

<http://support.intel.com/support/motherboards/server/S5000VCL>.

Telephone

All calls are billed per incident, levied in local currency at the applicable credit card exchange rate plus applicable taxes. (Intel reserves the right to change the pricing for telephone support at any time without notice.)

Before calling, fill out an Intel® Server Issue Report Form. An online / automatic submission version of this form is available at <http://support.intel.com/support/motherboards/server/>. For the fastest service, please submit your form via the Internet.

For an updated support contact list, see <http://www.intel.com/support/9089.htm/>

U.S. and Canada

1-800-404-2284

Europe

Belgium 02 714 3182

Denmark ... 38 487077

Finland 9 693 79297

France..... 01 41 918529

Germany ... 069 9509 6099

Holland 020 487 4562

Italy..... 02 696 33276

Norway 23 1620 50

Spain..... 91 377 8166

Sweden..... 08 445 1251

UK..... 870 6072439

In Asia-Pacific region

Australia.... 1800 649931

Cambodia.. 63 2 636 9797 (via Philippines)

China 800 820 1100 (toll-free)
..... 8 621 33104691 (not toll-free)

Hong Kong 852 2 844 4456

India..... 0006517 2 68303634 (manual toll-free. You need an IDD-equipped telephone)

Indonesia ... 803 65 7249

Korea 822 767 2595

Malaysia 1 800 80 1390

Myanmar... 63 2 636 9796 (via Philippines)

New Zealand 0800 444 365

Pakistan.... 632 63684 15 (IDD via Philippines)

Philippines 1 800 1 651 0117

Singapore .. 65 6213-1311

Taiwan 2 2545-1640

Thailand 1 800 631 0003

Vietnam 632 6368416 (IDD via Philippines)

Japan

Domestic.... 0120 868686

Outside country 81 298 47 0800

Latin America

Argentina .. Contact AT&T USA at 0-800 222 1288. Once connected, dial 800 843 4481

Brazil 001-916 377 0180

Chile

Easter Island. Contact AT&T USA at 800 800 311. Once connected, dial 800 843 4481

Mainland and Juan .. Contact AT&T USA at 800 225 288. Once connected, dial 800 843 4481

Colombia... Contact AT&T USA at 01 800 911 0010. Once connected, dial 800 843 4481

Costa Rica . Contact AT&T USA at 0 800 0 114 114. Once connected, dial 800 843 4481

Ecuador

(Andimate) Contact AT&T USA at 1 999 119. Once connected, dial 800 843 4481

(Pacifictel) Contact AT&T USA at 1 800 225 528. Once connected, dial 800 843 4481

Guatemala. Contact AT&T USA at 99 99 190. Once connected, dial 800 843 4481

Mexico Contact AT&T USA at 001 800 462 628 4240. Once connected, dial 800 843 4481

Miami 1 800 621 8423

Panama..... Contact AT&T USA at 00 800 001 0109. Once connected, dial 800 843 4481

Paraguay ... 001 916 377 0114

Peru 001 916 377 0114

Uruguay..... 001 916 377 0114

Venezuela... Contact AT&T USA at 0 800 2255 288. Once connected, dial 800 843 4481

Appendix D: Safety Information

English

Server Safety Information

This document applies to Intel® server boards, Intel® server chassis (pedestal and rack-mount) and installed peripherals. To reduce the risk of bodily injury, electrical shock, fire, and equipment damage, read this document and observe all warnings and precautions in this guide before installing or maintaining your Intel® server product.



In the event of a conflict between the information in this document and information provided with the product or on the website for a particular product, the product documentation takes precedence.



Your server should be integrated and serviced only by technically qualified persons.

You must adhere to the guidelines in this guide and the assembly instructions in your server manuals to ensure and maintain compliance with existing product certifications and approvals. Use only the described, regulated components specified in this guide. Use of other products / components will void the UL Listing and other regulatory approvals of the product, and may result in noncompliance with product regulations in the region(s) in which the product is sold.

Safety Warnings and Cautions

To avoid personal injury or property damage, before you begin installing the product, read, observe, and adhere to all of the following safety instructions and information. The following safety symbols may be used throughout the documentation and may be marked on the product and / or the product packaging.

| | |
|---|---|
| CAUTION | Indicates the presence of a hazard that may cause minor personal injury or property damage if the CAUTION is ignored. |
| WARNING | Indicates the presence of a hazard that may result in serious personal injury if the WARNING is ignored. |
|  | Indicates potential hazard if indicated information is ignored. |
|  | Indicates shock hazards that result in serious injury or death if safety instructions are not followed. |
|  | Indicates hot components or surfaces. |

| | |
|---|---|
|  | Indicates do not touch fan blades, may result in injury. |
|  | Indicates to unplug all AC power cord(s) to disconnect AC power |
|  | Please recycle battery |

Intended Application Uses

This product was evaluated as Information Technology Equipment (ITE), which may be installed in offices, schools, computer rooms, and similar commercial type locations. The suitability of this product for other product categories and environments (such as medical, industrial, residential, alarm systems, and test equipment), other than an ITE application, may require further evaluation.

Site Selection

The system is designed to operate in a typical office environment. Choose a site that is:

- Clean, dry, and free of airborne particles (other than normal room dust).
- Well-ventilated and away from sources of heat including direct sunlight and radiators.
- Away from sources of vibration or physical shock.
- Isolated from strong electromagnetic fields produced by electrical devices.
- In regions that are susceptible to electrical storms, we recommend you plug your system into a surge suppresser and disconnect telecommunication lines to your modem during an electrical storm.
- Provided with a properly grounded wall outlet.
- Provided with sufficient space to access the power supply cord(s), because they serve as the product's main power disconnect.

Equipment Handling Practices

Reduce the risk of personal injury or equipment damage:

- Conform to local occupational health and safety requirements when moving and lifting equipment.
- Use mechanical assistance or other suitable assistance when moving and lifting equipment.
- To reduce the weight for easier handling, remove any easily detachable components.

Power and Electrical Warnings

Caution: *The power button, indicated by the stand-by power marking, DOES NOT completely turn off the system AC power; 5V standby power is active whenever the system is plugged in. To remove power from system, you must unplug the AC power cord from the wall outlet. Your system may use more than one AC power cord. Make sure all AC power cords are unplugged. Make sure the AC power cord(s) is/are unplugged before you open the chassis, or add or remove any non hot-plug components.*

Do not attempt to modify or use an AC power cord if it is not the exact type required. A separate AC cord is required for each system power supply.

Some power supplies in Intel® servers use Neutral Pole Fusing. To avoid risk of shock use caution when working with power supplies that use Neutral Pole Fusing.

The power supply in this product contains no user-serviceable parts. Do not open the power supply. Hazardous voltage, current and energy levels are present inside the power supply. Return to manufacturer for servicing.

When replacing a hot-plug power supply, unplug the power cord to the power supply being replaced before removing it from the server.

To avoid risk of electric shock, turn off the server and disconnect the power cord, telecommunications systems, networks, and modems attached to the server before opening it.

Power Cord Warnings

If an AC power cord was not provided with your product, purchase one that is approved for use in your country.

Caution: *To avoid electrical shock or fire, check the power cord(s) that will be used with the product as follows:*

- *Do not attempt to modify or use the AC power cord(s) if they are not the exact type required to fit into the grounded electrical outlets*
- *The power cord(s) must meet the following criteria:*
- *The power cord must have an electrical rating that is greater than that of the electrical current rating marked on the product.*
- *The power cord must have safety ground pin or contact that is suitable for the electrical outlet.*
- *The power supply cord(s) is/are the main disconnect device to AC power. The socket outlet(s) must be near the equipment and readily accessible for disconnection.*
- *The power supply cord(s) must be plugged into socket-outlet(s) that is /are provided with a suitable earth ground.*

System Access Warnings

Caution: To avoid personal injury or property damage, the following safety instructions apply whenever accessing the inside of the product:

- Turn off all peripheral devices connected to this product.
- Turn off the system by pressing the power button to off.
- Disconnect the AC power by unplugging all AC power cords from the system or wall outlet.
- Disconnect all cables and telecommunication lines that are connected to the system.
- Retain all screws or other fasteners when removing access cover(s). Upon completion of accessing inside the product, refasten access cover with original screws or fasteners.
- Do not access the inside of the power supply. There are no serviceable parts in the power supply. Return to manufacturer for servicing.
- Power down the server and disconnect all power cords before adding or replacing any non hot-plug component.
- When replacing a hot-plug power supply, unplug the power cord to the power supply being replaced before removing the power supply from the server.

Caution: If the server has been running, any installed processor(s) and heat sink(s) may be hot. Unless you are adding or removing a hot-plug component, allow the system to cool before opening the covers. To avoid the possibility of coming into contact with hot component(s) during a hot-plug installation, be careful when removing or installing the hot-plug component(s).

Caution: To avoid injury do not contact moving fan blades. If your system is supplied with a guard over the fan, do not operate the system without the fan guard in place.

Rack Mount Warnings

The equipment rack must be anchored to an unmovable support to prevent it from tipping when a server or piece of equipment is extended from it. The equipment rack must be installed according to the rack manufacturer's instructions.

Install equipment in the rack from the bottom up, with the heaviest equipment at the bottom of the rack.

Extend only one piece of equipment from the rack at a time.

You are responsible for installing a main power disconnect for the entire rack unit. This main disconnect must be readily accessible, and it must be labeled as controlling power to the entire unit, not just to the server(s).

To avoid risk of potential electric shock, a proper safety ground must be implemented for the rack and each piece of equipment installed in it.

Electrostatic Discharge (ESD)

Caution: ESD can damage disk drives, boards, and other parts. We recommend that you perform all procedures at an ESD workstation. If one is not available, provide some ESD protection by wearing an antistatic wrist strap attached to chassis ground -- any unpainted metal surface -- on your server when handling parts.

Always handle boards carefully. They can be extremely sensitive to ESD. Hold boards only by their edges. After removing a board from its protective wrapper or from the server, place the board component side up on a grounded, static free surface. Use a conductive foam pad if available but not the board wrapper. Do not slide board over any surface.

Other Hazards

Battery Replacement

Caution: There is the danger of explosion if the battery is incorrectly replaced. When replacing the battery, use only the battery recommended by the equipment manufacturer.

Dispose of batteries according to local ordinances and regulations.

Do not attempt to recharge a battery.

Do not attempt to disassemble, puncture, or otherwise damage a battery.

Cooling and Airflow

Caution: Carefully route cables as directed to minimize airflow blockage and cooling problems.

For proper cooling and airflow, operate the system only with the chassis covers installed. Operating the system without the covers in place can damage system parts. To install the covers:

- Check first to make sure you have not left loose tools or parts inside the system.
- Check that cables, add-in boards, and other components are properly installed.
- Attach the covers to the chassis according to the product instructions.

Laser Peripherals or Devices

Caution: To avoid risk of radiation exposure and/or personal injury:

- Do not open the enclosure of any laser peripheral or device
- Laser peripherals or devices have are not user serviceable
- Return to manufacturer for servicing

Deutsch

Sicherheitshinweise für den Server

Das vorliegende Dokument bezieht sich auf Intel® Serverplatinen, Intel® Servergehäuse (Standfuß und Rack) sowie installierte Peripheriegeräte. Es enthält Warnungen und Vorsichtsmaßnahmen zur Vermeidung von Gefahren durch Verletzung, Stromschlag, Feuer und Beschädigungen von Geräten. Lesen Sie diese Dokument daher sorgfältig, bevor Sie Ihr Intel® Serverprodukt installieren oder warten.



Bei Widersprüchen zwischen den hier vorliegenden Angaben und den Informationen im Lieferumfang des Produkts oder auf der Website des betreffenden Produkts hat die Produktdokumentation Vorrang.



Die Integration und Wartung des Servers darf nur durch technisch qualifizierte Personen erfolgen.

Um die Einhaltung der vorhandenen Zulassungen und Genehmigungen für das Produkt zu gewährleisten, sind die Richtlinien in diesem Handbuch sowie die Montageanleitungen in den Serverhandbüchern zu beachten. Verwenden Sie nur die beschriebenen, zugelassenen Komponenten, die im vorliegenden Handbuch angegeben werden. Die Verwendung anderer Produkte oder Komponenten führt zum Erlöschen der UL-Zulassung und anderer Genehmigungen für das Produkt. Dadurch kann das Produkt gegen Produktbestimmungen verstoßen, die im Verkaufsland gelten.

Sicherheitshinweise und Vorsichtsmaßnahmen

Um Verletzungen und Beschädigungen zu vermeiden, sollten Sie vor dem Beginn der Produktinstallation die nachfolgend aufgeführten Sicherheitshinweise und -informationen sorgfältig lesen und befolgen. In dem vorliegenden Handbuch sowie auf dem Produkt und auf der Verpackung werden folgende Sicherheitssymbole verwendet:

| | |
|---|--|
| VORSICHT | Weist auf eine Gefahrenquelle hin, die bei Nichtbeachtung des VORSICHTSHINWEISES zu leichteren Verletzungen bzw. Sachbeschädigungen führen kann. |
| WARNUNG | Weist auf eine Gefahrenquelle hin, die bei Nichtbeachtung der WARNUNG zu ernstesten Verletzungen führen kann. |
|  | Weist auf potentielle Gefahr bei Nichtbeachtung der angezeigten Informationen hin. |
|  | Weist auf die Gefahr eines Stromschlags hin, der bei Nichtbeachtung der Sicherheitshinweise zu schweren oder tödlichen Verletzungen führen kann. |
|  | Weist auf Verbrennungsgefahr an heißen Bauteilen bzw. Oberflächen hin. |

| | |
|---|--|
|  | Weist darauf hin, daß das Anfassen des Gebläses zu Verletzungen führen kann. |
|  | Bedeutet, alle Netzkabel abzuziehen und das Gerät von der Netzspannung zu trennen. |
|  | Bereiten Sie bitte Batterie auf |

Zielbenutzer der Anwendung

Dieses Produkt wurde in seiner Eigenschaft als IT-Gerät getestet, das in Büros, Schulen, Computerräumen und ähnlichen öffentlichen Räumlichkeiten installiert werden kann. Die Eignung dieses Produkts für andere Einsatzbereiche als IT (z. B. Medizin, Industrie, Alarmsysteme oder Prüfgeräte) kann u. U. weitere Tests erfordern.

Standortauswahl

Das System ist für den Betrieb innerhalb normaler Büroumgebungen geeignet. Wählen Sie einen Standort, der folgenden Kriterien entspricht:

- Sauber, trocken und frei von Partikeln in der Luft (außer dem normalen Raumstaub).
- Gut belüftet, nicht in der Nähe von Wärmequellen und keiner direkten Sonnenbestrahlung ausgesetzt.
- Nicht in der Nähe von Vibrations- oder Erschütterungsquellen.
- Abgeschirmt von starken elektromagnetischen Feldern, die durch elektrische Geräte erzeugt werden.
- In gewittergefährdeten Gebieten sollten Sie das System an einen Überspannungsschutz anschließen und bei einem Gewitter die Telekommunikationskabel zum Modem abziehen.
- Eine ordnungsgemäß geerdete Wandsteckdose muß vorhanden sein.
- Ausreichender Freiraum für den Zugang zu den Netzkabeln, da diese die Hauptvorrichtung zum Trennen des Produkts von der Stromversorgung sind.

Handhabung von Geräten

Beachten Sie zur Vermeidung von Verletzungen oder Beschädigungen an den Geräten die folgenden Hinweise:

- Halten Sie beim Transportieren und Anheben von Geräten die örtlichen Gesundheits- und Sicherheitsvorschriften ein.
- Verwenden Sie mechanische oder andere geeignete Hilfsmittel zum Transportieren oder Anheben von Geräten.
- Entfernen Sie alle Komponenten, die sich leicht abnehmen lassen, um das Gewicht zu reduzieren und die Handhabung zu erleichtern.

Warnungen zu Netzspannung und Elektrizität

Caution: *Durch Betätigen der mit dem Standby-Symbol gekennzeichneten Netztaste wird das System NICHT vollständig vom Netz getrennt. Es sind weiterhin 5 V aktiv, solange das System eingesteckt ist. Um das System vollständig vom Strom zu trennen, muß das Netzkabel aus der Steckdose abgezogen werden. Das System verfügt möglicherweise über mehrere Netzkabel. Vergewissern Sie sich in diesem Fall, daß alle Netzkabel abgezogen sind. Wenn Sie Komponenten ein- oder ausbauen möchten, die nicht hot-plug-fähig sind, stellen Sie sicher, daß zuvor alle Netzkabel abgezogen sind.*

Nehmen Sie keine Änderungen am Netzkabel vor, und verwenden Sie kein Kabel, das nicht genau dem geforderten Typ entspricht. Jedes Netzteil im System muß über ein eigenes Netzkabel angeschlossen werden.

Einige Netzteile von Intel Servern verwenden Nullleitersicherungen. Vorsicht ist geboten im Umgang mit Netzteilen, welche Nullleitersicherungen verwenden, um das Risiko eines elektrischen Schlages zu vermeiden

Das Netzteil in diesem Produkt enthält keine Teile, die vom Benutzer gewartet werden können. Öffnen Sie das Netzteil nicht. Im Netzteil bestehen gefährliche Spannungen, Ströme und Energiequellen. Schicken Sie das Gerät für Wartungsarbeiten an den Hersteller zurück.

Wenn Sie ein hot-plug-fähiges Netzteil austauschen, ziehen Sie dessen Netzkabel ab, bevor Sie es aus dem Server ausbauen.

Zur Vermeidung von Stromschlägen schalten Sie den Server aus, und trennen Sie vor dem Öffnen des Geräts das Netzkabel sowie alle an den Server angeschlossene Telekommunikationssysteme, Netzwerke und Modems.

Hinweis für Netzkabel

Wenn kein Netzkabel mit dem Produkt geliefert wurde, kaufen Sie ein Kabel, das für die

Caution: *Prüfen Sie zur Vermeidung von Stromschlag oder Feuergefahr die mit dem Produkt zu verwendenden Netzkabel wie folgt:*

- *Nehmen Sie keine Änderungen an einem Netzkabel vor, und benutzen sie es nicht, wenn es nicht genau in die geerdeten Netzsteckdosen paßt.*
- *Netzkabel müssen die folgenden Anforderungen erfüllen:*
 - *Die Nennbelastbarkeit des Netzkabels muß mindestens so hoch sein wie die am Produkt angegebenen Nennstromaufnahme.*
 - *Das Netzkabel muß einen zur Netzsteckdose passenden Schutzkontakt besitzen.*
- *Die Netzkabel sind die Hauptvorrichtung zum Trennen des Geräts vom Stromnetz. Die Steckdose muß in der Nähe der Anlage angebracht und gut erreichbar sein.*
- *Netzkabel müssen an eine ordnungsgemäß geerdete Steckdose angeschlossen sein.*

Warnhinweise für den Systemzugang

Caution: Um Verletzungen und Beschädigungen zu vermeiden, sollten Sie vor Arbeiten im Produktinneren folgende Sicherheitsanweisungen beachten:

- Schalten Sie alle am Produkt angeschlossenen Peripheriegeräte aus.
- Schalten Sie das System mit dem Netzschalter aus.
- Trennen Sie das Gerät von der Stromquelle, indem Sie alle Netzkabel vom System bzw. aus der Steckdose ziehen.
- Ziehen Sie alle Kabel und alle an das System angeschlossenen Telekommunikationsleitungen ab.
- Bewahren Sie alle Schrauben und anderen Befestigungselemente gut auf, nachdem Sie die Gehäuseabdeckung entfernt haben. Wenn Sie Ihre Arbeiten im Systeminneren beendet haben, befestigen Sie die Gehäuseabdeckung mit den Originalschrauben bzw. -befestigungselementen.
- Führen Sie keine Arbeiten im Netzteil aus. Das Netzteil enthält keine für den Benutzer wartungsbedürftigen Teile. Schicken Sie das Gerät für Wartungsarbeiten an den Hersteller zurück.
- Schalten Sie den Server aus, und ziehen Sie alle Netzkabel ab, bevor Sie Komponenten ein- oder ausbauen, die nicht hot-plug-fähig sind.
- Wenn Sie ein hot-plug-fähiges Netzteil austauschen, ziehen Sie dessen Netzkabel ab, bevor Sie es aus dem Server ausbauen.

Caution: War Ihr Server in Betrieb, können die installierten Prozessoren und Kühlkörper heiß sein. Sofern Sie keine Hot-Plug-Komponenten ein- oder ausbauen, warten Sie mit dem Abnehmen der Abdeckungen, bis das System abgekühlt ist. Gehen Sie beim Aus- oder Einbauen von Hot-Plug-Komponenten sorgfältig vor, um nicht mit heißen Komponenten in Berührung zu kommen.

Caution: Berühren Sie nicht die rotierenden Lüfterflügel, um Verletzungen zu vermeiden. Falls Ihr System mit einer Lüfterabdeckung besitzt, darf es nicht ohne diese Abdeckung betrieben werden.

Warnhinweise für Racks

Das Geräte-Rack muß auf einer geeigneten, festen Unterlage verankert werden, um ein Umkippen zu vermeiden, wenn ein Server oder andere Geräte herausgezogen werden. Bei der Installation des Racks müssen die Anweisungen des Rack-Herstellers beachtet werden.

Gehen Sie bei der Installation von Geräten im Rack immer von unten nach oben vor, und bauen Sie das schwerste Gerät an der untersten Position im Rack ein.

Ziehen Sie jeweils immer nur ein Gerät aus dem Rack heraus.

Sie müssen für die gesamte Rack-Einheit einen Netztrennschalter einrichten. Dieser Netztrennschalter muß leicht zugänglich sein und über eine Kennzeichnung verfügen, die besagt, daß er die Stromzufuhr zur gesamten Einheit steuert und nicht nur zu den Servern.

Zur Vermeidung von Stromschlaggefahr müssen das Rack selbst und alle darin eingebauten Geräte ordnungsgemäß geerdet sein.

Elektrostatische Entladungen (ESD)

Caution: *Elektrostatische Entladungen können zur Beschädigung von Festplatten, Platinen und anderen Komponenten führen. Daher sollten Sie alle Arbeiten an einer ESD-Workstation ausführen. Steht ein solcher Arbeitsplatz nicht zur Verfügung, erzielen Sie einen gewissen Schutz vor elektrostatischen Entladungen durch Tragen einer Antistatik-Manschette, die Sie während der Arbeit zur Erdung an einem beliebigen unlackierten Metallteil des Computergehäuses befestigen.*

Gehen Sie bei der Handhabung von Platinen immer mit größter Vorsicht vor. Sie können äußerst empfindlich gegenüber elektrostatischer Entladung sein. Halten Sie Platinen nur an den Kanten fest. Legen Sie die Platinen nach dem Auspacken aus der Schutzhülle oder nach dem Ausbau aus dem Server mit der Bauelementseite nach oben auf eine geerdete, statisch entladene Unterlage. Verwenden Sie dazu, sofern verfügbar, eine leitfähige Schaumstoffunterlage, aber nicht die Schutzhülle der Platine. Ziehen Sie die Platine nicht über eine Fläche.

Andere Gefahren

Batterieaustausch

Caution: *Wird die Batterie unsachgemäß ausgetauscht, besteht Explosionsgefahr. Verwenden Sie als Ersatz nur die vom Gerätehersteller empfohlene Batterie.*

Beachten Sie bei der Entsorgung von Batterien die gültigen Bestimmungen.

Versuchen Sie nicht, eine Batterie aufzuladen.

Versuchen Sie nicht, eine Batterie zu öffnen oder sonstwie zu beschädigen.

Kühlung und Luftstrom

Caution: *Verlegen Sie Kabel sorgfältig entsprechend der Anleitung, um Störungen des Luftstroms und Kühlungsprobleme zu vermeiden.*

Zur Gewährleistung des ordnungsgemäßen Kühlungs- und Luftstromverhaltens darf das System nur mit angebrachten Gehäuseabdeckungen betrieben werden. Die Inbetriebnahme des Systems ohne Abdeckung kann zur Beschädigung von Systemkomponenten führen. So bringen Sie die Abdeckung wieder an:

- Vergewissern Sie sich zunächst, daß Sie keine Werkzeuge oder Teile im Gehäuse vergessen haben.

- Vérifiez que les câbles, les cartes d'extension et les autres composants sont correctement installés.
- Fixez les couvercles du boîtier du produit, comme décrit dans le manuel d'installation.

Laser-Peripheralgeräte oder -Komponenten

Caution: Beachten Sie zur Vermeidung von Strahlung und Verletzungen die folgenden Hinweise:

- Öffnen Sie keinesfalls das Gehäuse von Laser-Peripheralgeräten oder Laser-Komponenten.
- Laser-Peripheralgeräte oder -Komponenten besitzen keine für den Benutzer wartungsbedürftigen Teile.
- Schicken Sie das Gerät für Wartungsarbeiten an den Hersteller zurück.

Français

Consignes de sécurité sur le serveur

Ce document s'applique aux cartes serveur Intel[®], au châssis de serveur Intel[®] (sur pieds et sur rack) et aux périphériques installés. Pour réduire les risques de dommages corporels, d'électrocution, d'incendie et de dommages matériels, lisez ce document et respectez tous les avertissements et précautions mentionnés dans ce guide avant d'installer ou de mettre à jour votre produit serveur Intel[®].







En cas de conflit entre les informations fournies dans ce document et celles livrées avec le produit ou publiées sur le site Web pour un produit particulier, la documentation du produit prime.

Votre serveur doit être intégré et entretenu uniquement par des techniciens qualifiés.

Vous devez suivre les informations de ce guide et les instructions d'assemblage des manuels de serveur pour vérifier et maintenir la conformité avec les certifications et approbations de produit existantes. Utilisez uniquement les composants décrits et réglementés spécifiés dans ce guide. L'utilisation d'autres produits/composants annulera la liste UL et les autres approbations réglementaires du produit, et le produit peut ne pas être conforme aux autres lois et réglementations locales applicables au produit.

Sécurité: avertissements et mises en garde

Pour éviter de vous blesser ou d'endommager votre équipement, lisez et respectez toutes les informations et consignes de sécurité avant de commencer l'installation du produit. Les symboles de sécurité suivants peuvent être utilisés tout au long de cette documentation et peuvent figurer sur le produit ou sur son emballage.

| | |
|---|--|
| ATTENTION | Indique la présence d'un risque pouvant entraîner des blessures physiques mineures ou endommager légèrement le matériel si la mise en garde n'est pas prise en compte. |
| AVERTISSEMENT | Indique la présence d'un risque pouvant entraîner des blessures corporelles graves si l'avertissement n'est pas pris en compte. |
|  | Indique un risque potentiel si les informations signalées ne sont pas prises en compte. |
|  | Indique des risques d'électrocution pouvant entraîner des blessures corporelles graves ou mortelles si les consignes de sécurité ne sont pas respectées. |
|  | Signale des composants ou des surfaces soumis à des températures élevées. |
|  | Indique de ne pas toucher aux pales de ventilateur, car cela peut entraîner des blessures. |
|  | Indique de débrancher tous les cordons d'alimentation secteur pour déconnecter l'alimentation. |
|  | Veuillez réutiliser la batterie |

Domaines d'utilisation prévus

Ce produit a été testé comme équipement informatique (ITE) et peut être installé dans des bureaux, des écoles, des salles informatiques et des endroits commerciaux similaires. L'utilisation du présent produit dans des catégories et environnements de produits et domaines d'application (par exemple, le domaine médical, industriel, résidentiel, les systèmes d'alarme et les appareils de contrôle) autres qu'ITE doit faire l'objet d'évaluations supplémentaires.

Sélection d'un emplacement

Le système est conçu pour fonctionner dans un environnement standard de bureau. Choisissez un emplacement respectant les conditions suivantes :

- Propre, sec et exempt de particules en suspension (autres que la poussière normale d'une pièce).
- Bien ventilé et à l'écart des sources de chaleur telles que la lumière directe du soleil et les radiateurs.
- À l'écart des sources de vibration ou des chocs physiques.
- Isolé des champs électromagnétiques importants produits par des appareils électriques.

- Dans les régions sujettes aux orages magnétiques, nous vous recommandons de brancher votre système à un suppresseur de surtension et de déconnecter les lignes de télécommunication de votre modem pendant les orages.
- Équipé d'une prise murale reliée à la terre.
- Équipé d'un espace suffisant pour accéder aux cordons d'alimentation secteur, car ils servent de disjoncteur principal d'alimentation du produit.

Pratiques de manipulation de l'équipement

Réduisez le risque de dommages personnels ou matériels :

- Conformez-vous aux exigences de médecine du travail et de sécurité lorsque vous déplacez et soulevez le matériel.
- Utilisez l'assistance mécanique ou toute autre assistance appropriée lorsque vous déplacez et soulevez le matériel.
- Pour réduire le poids en vue de faciliter la manipulation, retirez tout composant amovible.

Alimentation et avertissements en matière d'électricité



Attention: Le bouton d'alimentation, indiqué par le symbole de mise en veille, NE COUPE PAS complètement l'alimentation secteur du système car le courant de veille 5 V reste actif lorsque le système est sous tension. Pour couper l'alimentation du système, vous devez débrancher le cordon d'alimentation secteur de la prise murale. Votre système peut utiliser plusieurs cordons d'alimentation secteur. Assurez-vous que tous les cordons d'alimentation sont débranchés. Vous devez les débrancher avant d'ouvrir le châssis, d'ajouter ou de supprimer un composant non connectable à chaud.

Les alimentations de certains serveurs Intel sont munies de doubles fusibles pôle/neutre: veuillez observer les précautions d'usage afin d'éviter tout risque d'électrocution.

N'essayez pas de modifier ou d'utiliser un cordon d'alimentation secteur s'il ne s'agit pas du type exact requis. Un cordon secteur est requis pour chaque alimentation système.

Le bloc d'alimentation de ce produit ne contient aucun composant réparable par l'utilisateur. N'ouvrez pas le bloc d'alimentation. L'intérieur de celui-ci est soumis à des

niveaux dangereux de tension, de courant et d'énergie. Renvoyez-le au fabricant en cas de problème.

Lorsque vous remplacez un bloc d'alimentation à chaud, débranchez le cordon du bloc d'alimentation en cours de remplacement avant de le retirer du serveur.

Pour éviter tout risque d'électrocution, mettez le système hors tension et débranchez les cordons d'alimentation ainsi que les systèmes de télécommunication, réseaux et modems reliés au système avant d'ouvrir ce dernier.

Avertissements sur le cordon d'alimentation

Si aucun cordon d'alimentation secteur n'a été fourni avec votre produit, vous devez vous en procurer un qui soit approuvé pour une utilisation dans votre pays.



Attention: Pour éviter tout risque d'électrocution ou d'incendie, vérifiez les cordons d'alimentation qui seront utilisés avec le produit comme suit :

- N'essayez pas d'utiliser ou de modifier les cordons d'alimentation en CA s'ils ne correspondent pas exactement au type requis pour les prises électriques reliées à la terre.
- Les cordons d'alimentation doivent répondre aux critères suivants :
 - Le cordon d'alimentation doit supporter une intensité supérieure à celle indiquée sur le produit.
 - Le cordon d'alimentation doit posséder une broche ou un contact de mise à la terre approprié à la prise électrique.
- Les cordons d'alimentation électrique représentent le principal dispositif de déconnexion raccordé à l'alimentation secteur. Les prises de courant doivent se trouver à proximité de l'équipement et être facilement accessibles pour une déconnexion.
- Les cordons d'alimentation doivent être branchés sur des prises électriques correctement reliées à la terre.

Avertissements sur l'accès au système



Attention: Pour éviter de vous blesser ou d'endommager votre équipement, les consignes de sécurité suivantes s'appliquent chaque fois que vous accédez à l'intérieur du produit :

- Mettez hors tension tous les périphériques connectés à ce produit.
- Éteignez le système en appuyant sur le bouton d'alimentation.
- Déconnectez l'alimentation secteur en débranchant tous les cordons d'alimentation secteur du système ou de la prise murale.
- Déconnectez l'ensemble des câbles et lignes de télécommunication qui sont connectés au système.

- Mettez toutes les vis ou autres attaches de côté lorsque vous retirez les panneaux d'accès. Une fois que vous avez terminé d'accéder à l'intérieur du produit, refixez le panneau d'accès avec les vis ou attaches d'origine.
- N'essayez pas d'accéder à l'intérieur du bloc d'alimentation. Il ne contient aucune pièce réparable. Renvoyez-le au fabricant en cas de problème.
- Mettez le serveur hors tension et débranchez tous les cordons d'alimentation avant d'ajouter ou de remplacer tout composant non connectable à chaud.
- Lorsque vous remplacez le bloc d'alimentation à chaud, débranchez le cordon du bloc d'alimentation en cours de remplacement avant de retirer le bloc du serveur.



Attention: Si le serveur a été utilisé, les processeurs et dissipateurs de chaleur installés peuvent être chauds. À moins que vous n'ajoutiez ou ne retiriez un composant connectable à chaud, laissez le système refroidir avant d'ouvrir les panneaux. Pour éviter tout risque d'entrer en contact avec un composant chaud lors d'une installation à chaud, prenez toutes les précautions nécessaires lorsque vous retirez ou installez des composants connectables à chaud.



Attention: Pour éviter de vous blesser, ne touchez pas les pales de ventilateur en mouvement. Si votre système est fourni avec une protection sur le ventilateur, ne mettez pas le système en route sans la protection en place.

Avertissements sur le montage en rack

Le rack doit être fixé à un support inamovible pour éviter qu'il ne bascule lors de l'extension d'un serveur ou d'un élément de l'équipement. Le rack doit être installé conformément aux instructions du fabricant.

Installez les équipements dans le rack en partant du bas, en plaçant le plus lourd en bas du rack.

N'étendez qu'un seul élément de l'équipement à partir du rack à la fois.

Vous êtes responsable de l'installation d'un disjoncteur principal d'alimentation pour la totalité du rack. Ce disjoncteur principal doit être rapidement accessible et doit être étiqueté comme contrôlant toute l'unité, et pas uniquement le ou les serveurs.

Pour éviter tout risque d'électrocution, le rack et chaque élément de l'équipement installé dans le rack doivent être correctement reliés à la terre.

Décharges électrostatiques (ESD)



Attention: Les décharges électrostatiques (ESD) peuvent endommager les lecteurs de disque dur, les cartes et d'autres pièces. Il est fortement conseillé d'effectuer l'ensemble des procédures décrites à un poste de travail protégé contre les ESD. Au cas où aucun poste de ce type ne serait disponible, protégez-vous contre les ESD en portant un bracelet antistatique relié à la masse du châssis (n'importe quelle surface métallique non peinte) de votre serveur lorsque que vous manipulez les pièces.

Manipulez toujours les cartes avec précaution. Elles peuvent être extrêmement sensibles aux ESD. Ne tenez les cartes que par leurs bords. Après avoir retiré une carte de son emballage de protection ou du serveur, placez-la sur une surface reliée à la terre, exempte de charge statique, composants orientés vers le haut. Utilisez si possible un tapis de mousse conducteur, mais pas l'emballage de la carte. Veillez à ce que la carte ne glisse sur aucune surface.

Autres risques

Remplacement de la pile



Attention: Il existe un risque d'explosion si la pile n'est pas correctement remplacée. Lors du remplacement de la pile, utilisez uniquement celle recommandée par le fabricant du matériel.

Mettez la pile au rebut en vous conformant aux réglementations locales.

N'essayez pas de recharger une pile.

N'essayez pas de démonter, de percer ou d'endommager la pile d'une quelconque façon.

Refroidissement et ventilation



Attention: Routez les câbles avec précaution comme indiqué pour minimiser les blocages de circulation d'air et les problèmes de refroidissement.

Afin de permettre une ventilation et un refroidissement corrects, ne mettez le système en marche que lorsque les panneaux du châssis sont en place. L'utilisation du système sans les panneaux peut endommager les composants système. Pour installer les panneaux :

- Vérifiez tout d'abord que vous n'avez pas oublié d'outils ou de composants détachés à l'intérieur du système.
- Vérifiez que les câbles, les cartes d'extension et les autres composants sont correctement installés.
- Fixez les panneaux au châssis en suivant les instructions du produit.

Périphériques laser



Attention: Pour éviter tout risque d'exposition aux rayonnements et/ou de dommage personnel:

- *N'ouvrez pas l'enceinte d'un périphérique laser.*
- *Les périphériques laser ne sont pas réparables par l'utilisateur.*
- *Retournez-les au fabricant en cas de problème.*

Español

Información de seguridad del servidor

Este documento se aplica a las tarjetas de servidor de Intel®, las carcasas de servidor de Intel® (montaje en bastidor y en pedestal) y los dispositivos periféricos. Para reducir el riesgo de daños corporales, descargas eléctricas, fuego y en el equipo, lea este documento y preste atención a todos las advertencias y precauciones de esta guía antes de instalar o mantener el producto de servidor de Intel®.

En el caso de que haya diferencias entre la información para un producto en particular contenida en este documento y la información proporcionada con dicho producto o en el sitio Web, la documentación del producto es la que prevalece.







Sólo personal técnico cualificado debe montar y prestar los servicios para el servidor.

Debe ceñirse a las directrices de esta guía y a las instrucciones de montaje de los manuales del servidor para asegurar y mantener el cumplimiento con las certificaciones y homologaciones existentes de los productos. Utilice sólo los componentes descritos y homologados que se especifican en esta guía. El uso de otros productos o componentes anulará la homologación UL y otras certificaciones oficiales del producto, pudiendo dejar de ser compatible con las normativas locales de los países en los que se comercializa.

Advertencias y precauciones sobre seguridad

Para reducir la posibilidad de que se produzcan lesiones personales o daños en la propiedad, antes de empezar a instalar el producto, lea, observe y cumpla toda la información e instrucciones de seguridad siguientes. Puede que se utilicen los siguientes símbolos de seguridad en la documentación y es posible que aparezcan en el producto o en su embalaje.

| | |
|--------------------|---|
| PRECAUCIÓN | Indica la existencia de un riesgo que podría causar lesiones personales o daños en la propiedad leves si no se tiene en cuenta la PRECAUCIÓN. |
| ADVERTENCIA | Indica la existencia de un riesgo que podría causar lesiones personales graves si no se tiene en cuenta la ADVERTENCIA. |

| | |
|---|--|
|  | Indica un riesgo potencial si no se tiene en cuenta la información indicada. |
|  | Indica riesgo de descargas eléctricas que podrían causar lesiones graves o la muerte si no se siguen las instrucciones de seguridad. |
|  | Indica componentes o superficies calientes. |
|  | Indica que no se deben tocar las aspas de los ventiladores, ya que de lo contrario se podrían producir lesiones. |
|  | Indica que es necesario desenchufar los cables de alimentación de CA para desconectar la alimentación de CA |
|  | Recicle por favor la batería |

Aplicaciones y usos previstos

Este producto ha sido evaluado como equipo de tecnología informática (ITE) que puede instalarse en oficinas, escuelas, salas de equipos informáticos o lugares de ámbito comercial similares. Es posible que sea necesario llevar a cabo una evaluación adicional para comprobar si este producto es apropiado para otras categorías de productos y entornos además de las aplicaciones informáticas (por ejemplo, soluciones médicas, industriales, residenciales, sistemas de alarma y equipos de pruebas).

Selección de la ubicación

El sistema se ha diseñado para funcionar en un entorno normal de oficinas. Seleccione una ubicación que esté:

- Limpia, seca y libre de macropartículas en suspensión en el aire (que no sean el polvo habitual de la habitación).
- Bien ventilada y alejada de fuentes de calor, incluida la luz solar directa y los radiadores.
- Alejada de fuentes de vibración o de golpes físicos.
- Aislada de campos electromagnéticos producidos por dispositivos eléctricos.
- En zonas propensas a tormentas eléctricas, se recomienda que conecte el servidor a un supresor de sobretensiones y desconecte las líneas de telecomunicaciones al módem durante una tormenta eléctrica.
- Provista de una toma de corriente alterna correctamente conectada a tierra.
- Provista de espacio suficiente para acceder a los cables de la fuente de alimentación ya que constituyen la desconexión principal de la alimentación.

Manipulación del equipo

Reduzca el riesgo de daños personales o en el equipo:

- Respete los requisitos de sanidad y seguridad laborales de su país cuando traslade y levante el equipo.
- Utilice medios mecánicos u otros que sean adecuados al trasladar o levantar el equipo.
- Para que el peso sea menor para manipularlo con más facilidad, extraiga los componentes que sean de fácil extracción.

Advertencias de alimentación y eléctricas



Precaución: El botón de encendido, indicado con la marca del modo de reposo o stand-by, NO DESCONECTA completamente la alimentación de CA del sistema, ya que el modo de reposo de 5 V sigue activo mientras el sistema está enchufado. Para desconectar el sistema debe desenchufar el cable de alimentación de CA de la toma de la pared. Puede usar más de un cable de alimentación de CA con el sistema. Asegúrese de que todos los cables de alimentación de CA están desenchufados. Asegúrese de que los cables de alimentación de CA estén desenchufado antes de abrir la carcasa, agregar o extraer cualquier componente que no es de conexión en funcionamiento.

Algunas fuentes de alimentación de electricidad de los servidores de Intel utilizan el polo neutral del fuselaje. Para evitar riesgos de choques eléctricos use precauciones al trabajar con las fuentes de alimentación que utilizan el polo neutral de fuselaje.

No intente modificar ni utilizar un cable de alimentación de CA si no es del tipo exacto requerido. Se necesita un cable de CA para cada fuente de alimentación del sistema.

La fuente de alimentación de este producto no contiene piezas que puedan ser reparadas por el usuario. No abra la fuente de alimentación. Dentro de la fuente de alimentación puede haber niveles de tensión, corriente y energía peligrosos. Devuélvala al fabricante para repararla.

Al reemplazar una fuente de alimentación de conexión en funcionamiento, desenchufe el cable de alimentación de la fuente de alimentación que va a reemplazar antes de extraerla del servidor.

Para evitar el riesgo de descargas eléctricas, antes de abrir el servidor, apáguelo, desconecte el cable de alimentación, los sistemas de telecomunicaciones, las redes y los módems conectados al mismo.

Advertencias sobre el cable de alimentación

Si no se ha proporcionado con el producto ningún cable de alimentación de CA, adquiera alguno cuyo uso esté aprobado en su país.



Precaución: Para evitar descargas eléctricas o fuego, revise los cables de alimentación que usará con el producto tal y como se describe a continuación:

- *No intente modificar ni utilizar los cables de alimentación de CA si no son exactamente del modelo especificado para ajustarse a las tomas de corriente conectadas a tierra.*
- *Los cables de alimentación deben reunir los siguientes requisitos:*
 - *El cable de alimentación debe disponer de una capacidad nominal de corriente eléctrica mayor que la capacidad especificada en el producto.*
 - *El cable de alimentación debe disponer de una patilla o contacto de conexión a tierra que sea apto para la toma de corriente.*
- *Los cables de la fuente de alimentación son los dispositivos de desconexión principales a la corriente alterna. El enchufe o enchufes de zócalo deben encontrarse cerca del equipo y el acceso a ellos debe poderse efectuar de forma inmediata con el fin de desconectarlos.*
- *Los cables de la fuente de alimentación deben estar conectados a los enchufes con una toma de tierra adecuada.*

Advertencias el acceso al sistema



Precaución: Para evitar lesiones personales o daños en la propiedad, se aplican las siguientes instrucciones de seguridad siempre que se acceda al interior del producto:

- *Apague todos los dispositivos periféricos conectados a este producto.*
- *Pulse el botón de alimentación para apagar el sistema.*
- *Desconecte la alimentación de CA desenchufando los cables de alimentación de CA del sistema o de la toma de corriente alterna.*
- *Desconecte todos los cables y líneas de telecomunicación que estén conectados al sistema.*
- *Guarde todos los tornillos o elementos de fijación cuando retire las cubiertas de acceso. Cuando termine de operar en el interior del producto, vuelva a colocar los tornillos o los elementos de fijación originales de la cubierta de acceso.*
- *No acceda al interior de la fuente de alimentación. No hay elementos en la fuente de alimentación que usted pueda reparar y utilizar. Devuélvala al fabricante para repararla.*
- *Apague el servidor y desconecte todos los cables de alimentación antes de agregar o reemplazar cualquier componente que no es de conexión en funcionamiento.*

- *Al reemplazar una fuente de alimentación de conexión en funcionamiento, desenchufe el cable de alimentación de la fuente de alimentación que va a reemplazar antes de extraerla del servidor.*



Precaución: Si el servidor se ha estado ejecutando, los procesadores y disipadores de calor estarán recalentados. A no ser que esté instalando o extrayendo un componente de conexión en funcionamiento, deje que el sistema se enfríe antes de abrir las cubiertas. Para que no llegue a tocar los componentes que estén calientes cuando esté realizando una instalación de conexión en funcionamiento, tenga cuidado al extraer o instalar los componentes de conexión en funcionamiento.



Precaución: Para evitar posibles daños, no toque las aspas en movimiento de los ventiladores. Si el sistema se le ha suministrado con una protección para el ventilador, asegúrese de que cuando esté funcionando el sistema la protección esté en su sitio.

Advertencias sobre el montaje en bastidor

El bastidor del equipo se debe sujetar con un soporte fijo para evitar que se caiga cuando se extraiga un servidor o una pieza del mismo. El bastidor del equipo debe instalarse siguiendo las instrucciones del fabricante del bastidor.

Instale el equipo en el bastidor comenzando desde la parte de abajo, con el equipo más pesado en la parte inferior del bastidor.

Extraiga las piezas del equipo del bastidor de una a una.

El usuario es el responsable de la instalación de un dispositivo de desconexión de la alimentación principal para toda la unidad del bastidor. El acceso a este dispositivo de desconexión deberá ser de fácil acceso y deberán incluirse indicaciones que lo identifiquen como el control de alimentación eléctrica de toda la unidad, no sólo de los servidores.

Para evitar el riesgo de descargas eléctricas, deberá instalar una conexión a tierra apropiada para el bastidor y para cada pieza del equipo instalada en el mismo.

Descarga electrostática (ESD)



Precaución: Las descargas electrostáticas pueden dañar las unidades de disco, las tarjetas y otros componentes. Recomendamos que realice todos los procedimientos en una estación de trabajo protegida contra descargas electrostáticas. En caso de que no haya una disponible, protéjase de alguna forma contras las descargas llevando un brazaletes antiestático conectado a la toma de tierra de la carcasa (cualquier superficie de metal que no esté pintada) del servidor cuando manipule las piezas.

Manipule siempre las tarjetas con el máximo cuidado. Pueden ser sumamente sensibles a las descargas electrostáticas. Sujételas sólo por los bordes. Una vez extraída la tarjeta de su envoltorio de protección o del servidor, colóquela con el lado de los componentes hacia arriba sobre una superficie con toma de tierra y sin carga estática. Utilice una

almohadilla de espuma conductora si dispone de ella, pero nunca el envoltorio de la tarjeta. No deslice la tarjeta sobre ninguna superficie.

Otros riesgos

Sustitución de la batería



Precaución: Existe el peligro de explosión si la batería no se reemplaza correctamente. Al reemplazar la batería, utilice sólo la batería recomendada por el fabricante del equipo.

Deseche las baterías respetando la normativa local.

No intente recargar la batería.

No intente desmontar, pinchar o causar cualquier otro desperfecto a una batería.

Enfriamiento y circulación de aire

Precaución: El tendido de los cables debe realizarse cuidadosamente tal y como se le indica para reducir al mínimo los problemas de obstrucción de la ventilación y de refrigeración.

Para conseguir una refrigeración y corriente de aire adecuadas, compruebe que cuando sistema esté funcionando, las cubiertas de la carcasa están instaladas. Si utiliza el sistema sin las cubiertas, podría dañar sus componentes. Para instalar las cubiertas:

- *Compruebe primero que no ha dejado herramientas o piezas sueltas dentro del sistema.*
- *Compruebe que los cables, tarjetas adicionales y otros componentes están instalados correctamente.*
- *Sujete las cubiertas a la carcasa siguiendo las instrucciones del producto.*



Periféricos o dispositivos láser

Precaución Para evitar el riesgo de la exposición a radiaciones o de daños personales:

- *No abra la caja de ningún periférico o dispositivo láser*
- *Los periféricos o dispositivos láser no pueden ser reparados por el usuario*
- *Haga que el fabricante los repare*

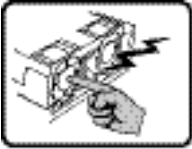
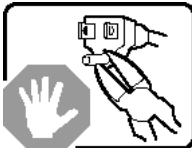

Appendix E: Installation / Assembly Safety Instructions

English

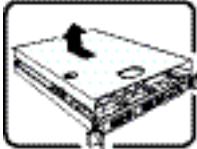
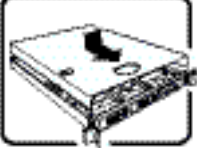
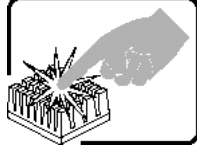
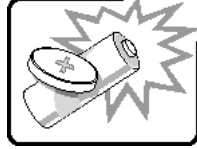
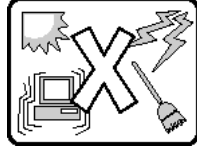
| | |
|---|--|
|  | <p>The power supply in this product contains no user-serviceable parts. Refer servicing only to qualified personnel.</p> |
|  | <p>Do not attempt to modify or use the supplied AC power cord if it is not the exact type required. A product with more than one power supply will have a separate AC power cord for each supply.</p> |
|  | <p>The power button on the system does not turn off system AC power. To remove AC power from the system, you must unplug each AC power cord from the wall outlet or power supply.</p> <p>The power cord(s) is considered the disconnect device to the main (AC) power. The socket outlet that the system plugs into shall be installed near the equipment and shall be easily accessible.</p> |
|  | <p>SAFETY STEPS: Whenever you remove the chassis covers to access the inside of the system, follow these steps:</p> <ol style="list-style-type: none">1. Turn off all peripheral devices connected to the system.2. Turn off the system by pressing the power button.3. Unplug all AC power cords from the system or from wall outlets.4. Label and disconnect all cables connected to I/O connectors or ports on the back of the system.5. Provide some electrostatic discharge (ESD) protection by wearing an antistatic wrist strap attached to chassis ground of the system-any unpainted metal surface-when handling components.6. Do not operate the system with the chassis covers removed. |

| | |
|---|---|
|  | <p>After you have completed the six SAFETY steps above, you can remove the system covers. To do this:</p> <ol style="list-style-type: none"> 1. Unlock and remove the padlock from the back of the system if a padlock has been installed. 2. Remove and save all screws from the covers. 3. Remove the cover(s). |
|  | <p>For proper cooling and airflow, always reinstall the chassis covers before turning on the system. Operating the system without the covers in place can damage system parts. To install the covers:</p> <ol style="list-style-type: none"> 1. Check first to make sure you have not left loose tools or parts inside the system. 2. Check that cables, add-in boards, and other components are properly installed. 3. Attach the covers to the chassis with the screws removed earlier, and tighten them firmly. 4. Insert and lock the padlock to the system to prevent unauthorized access inside the system. 5. Connect all external cables and the AC power cord(s) to the system. |
|  | <p>A microprocessor and heat sink may be hot if the system has been running. Also, there may be sharp pins and edges on some board and chassis parts. Contact should be made with care. Consider wearing protective gloves.</p> |
|  | <p>Danger of explosion if the battery is incorrectly replaced. Replace only with the same or equivalent type recommended by the equipment manufacturer. Dispose of used batteries according to manufacturer's instructions.</p> |
|  | <p>The system is designed to operate in a typical office environment. Choose a site that is:</p> <ul style="list-style-type: none"> • Clean and free of airborne particles (other than normal room dust). • Well ventilated and away from sources of heat including direct sunlight. • Away from sources of vibration or physical shock. • Isolated from strong electromagnetic fields produced by electrical devices. • In regions that are susceptible to electrical storms, we recommend you plug your system into a surge suppresser and disconnect telecommunication lines to your modem during an electrical storm. • Provided with a properly grounded wall outlet. • Provided with sufficient space to access the power supply cord(s), because they serve as the product's main power disconnect. |

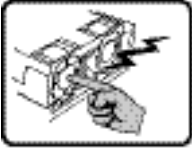
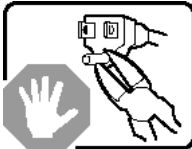
Deutsch

| | |
|---|---|
|  | <p>Benutzer können am Netzgerät dieses Produkts keine Reparaturen vornehmen. Das Produkt enthält möglicherweise mehrere Netzgeräte. Wartungsarbeiten müssen von qualifizierten Technikern ausgeführt werden.</p> |
|  | <p>Versuchen Sie nicht, das mitgelieferte Netzkabel zu ändern oder zu verwenden, wenn es sich nicht genau um den erforderlichen Typ handelt. Ein Produkt mit mehreren Netzgeräten hat für jedes Netzgerät ein eigenes Netzkabel.</p> |
|  | <p>Der Wechselstrom des Systems wird durch den Ein-/Aus-Schalter für Gleichstrom nicht ausgeschaltet. Ziehen Sie jedes Wechselstrom-Netzkabel aus der Steckdose bzw. dem Netzgerät, um den Stromanschluß des Systems zu unterbrechen.</p> |
|  | <p>SICHERHEISSMASSNAHMEN: Immer wenn Sie die Gehäuseabdeckung abnehmen um an das Systeminnere zu gelangen, sollten Sie folgende Schritte beachten:</p> <ol style="list-style-type: none">1. Schalten Sie alle an Ihr System angeschlossenen Peripheriegeräte aus.2. Schalten Sie das System mit dem Hauptschalter aus.3. Ziehen Sie den Stromanschlußstecker Ihres Systems aus der Steckdose.4. Auf der Rückseite des Systems beschriften und ziehen Sie alle Anschlußkabel von den I/O Anschlüssen oder Ports ab.5. Tragen Sie ein geerdetes Antistatik Gelenkband, um elektrostatische Ladungen (ESD) über blanke Metallstellen bei der Handhabung der Komponenten zu vermeiden.6. Schalten Sie das System niemals ohne ordnungsgemäß montiertes Gehäuse ein. |

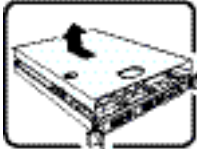
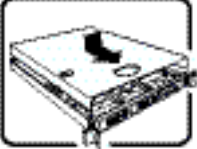
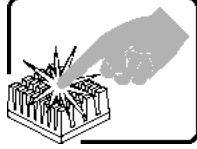
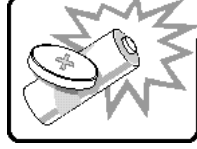
| | |
|---|--|
|  | <p>SICHERHEISSMASSNAHMEN: Immer wenn Sie die Gehäuseabdeckung abnehmen um an das Systeminnere zu gelangen, sollten Sie folgende Schritte beachten:</p> <ol style="list-style-type: none"> 1. Schalten Sie alle an Ihr System angeschlossenen Peripheriegeräte aus. 2. Schalten Sie das System mit dem Hauptschalter aus. 3. Ziehen Sie den Stromanschlußstecker Ihres Systems aus der Steckdose. 4. Auf der Rückseite des Systems beschrifteten und ziehen Sie alle Anschlußkabel von den I/O Anschlüssen oder Ports ab. 5. Tragen Sie ein geerdetes Antistatik Gelenkband, um elektrostatische Ladungen (ESD) über blanke Metallstellen bei der Handhabung der Komponenten zu vermeiden. 6. Schalten Sie das System niemals ohne ordnungsgemäß montiertes Gehäuse ein. |
|  | <p>Zur ordnungsgemäßen Kühlung und Lüftung muß die Gehäuseabdeckung immer wieder vor dem Einschalten installiert werden. Ein Betrieb des Systems ohne angebrachte Abdeckung kann Ihrem System oder Teile darin beschädigen. Um die Abdeckung wieder anzubringen:</p> <ol style="list-style-type: none"> 1. Vergewissern Sie sich, daß Sie keine Werkzeuge oder Teile im Innern des Systems zurückgelassen haben. 2. Überprüfen Sie alle Kabel, Zusatzkarten und andere Komponenten auf ordnungsgemäßen Sitz und Installation. 3. Bringen Sie die Abdeckungen wieder am Gehäuse an, indem Sie die zuvor gelösten Schrauben wieder anbringen. Ziehen Sie diese gut an. 4. Bringen Sie die Verschlusseinrichtung (Padlock) wieder an und schließen Sie diese, um ein unerlaubtes Öffnen des Systems zu verhindern. 5. Schließen Sie alle externen Kabel und den AC Stromanschlußstecker Ihres Systems wieder an. |
|  | <p>Der Mikroprozessor und der Kühler sind möglicherweise erhitzt, wenn das System in Betrieb ist. Außerdem können einige Platinen und Gehäuseteile scharfe Spitzen und Kanten aufweisen. Arbeiten an Platinen und Gehäuse sollten vorsichtig ausgeführt werden. Sie sollten Schutzhandschuhe tragen.</p> |
|  | <p>Bei falschem Einsetzen einer neuen Batterie besteht Explosionsgefahr. Die Batterie darf nur durch denselben oder einen entsprechenden, vom Hersteller empfohlenen Batterietyp ersetzt werden. Entsorgen Sie verbrauchte Batterien den Anweisungen des Herstellers entsprechend.</p> |

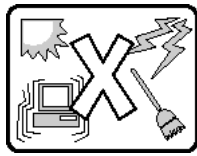

Das System wurde für den Betrieb in einer normalen Büroumgebung entwickelt. Der Standort sollte:

- "sauber und staubfrei sein (Hausstaub ausgenommen);
- "gut gelüftet und keinen Heizquellen ausgesetzt sein (einschließlich direkter Sonneneinstrahlung);
- "keinen Erschütterungen ausgesetzt sein;
- "keine starken, von elektrischen Geräten erzeugten elektromagnetischen Felder aufweisen;
- "in Regionen, in denen elektrische Stürme auftreten, mit einem Überspannungsschutzgerät verbunden sein; während eines elektrischen Sturms sollte keine Verbindung der Telekommunikationsleitungen mit dem Modem bestehen;
- "mit einer geerdeten Wechselstromsteckdose ausgerüstet sein;
- "über ausreichend Platz verfügen, um Zugang zu den Netzkabeln zu gewährleisten, da der Stromanschluß des Produkts hauptsächlich über die Kabel unterbrochen wird

Français

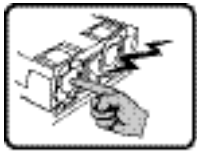

Le bloc d'alimentation de ce produit ne contient aucune pièce pouvant être réparée par l'utilisateur. Ce produit peut contenir plus d'un bloc d'alimentation. Veuillez contacter un technicien qualifié en cas de problème.

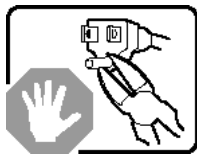

Ne pas essayer d'utiliser ni modifier le câble d'alimentation CA fourni, s'il ne correspond pas exactement au type requis. Le nombre de câbles d'alimentation CA fournis correspond au nombre de blocs d'alimentation du produit

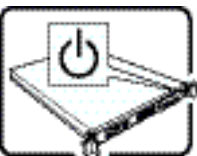



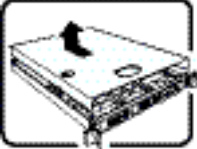
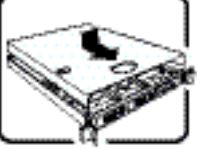
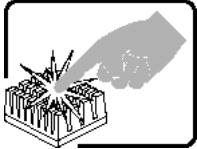

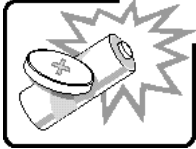
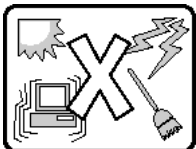
Notez que le commutateur CC de mise sous tension /hors tension du panneau avant n'éteint pas l'alimentation CA du système. Pour mettre le système hors tension, vous devez débrancher chaque câble d'alimentation de sa prise.

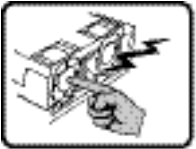
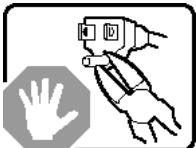

| | |
|---|---|
|  | <p>CONSIGNES DE SÉCURITÉ -Lorsque vous ouvrez le boîtier pour accéder à l'intérieur du système, suivez les consignes suivantes:</p> <ol style="list-style-type: none"> 1. Mettez hors tension tous les périphériques connectés au système. 2. Mettez le système hors tension en mettant l'interrupteur général en position OFF (bouton-poussoir). 3. Débranchez tous les cordons d'alimentation c.a. du système et des prises murales. 4. Identifiez et débranchez tous les câbles reliés aux connecteurs d'E-S ou aux accès derrière le système. 5. Pour prévenir les décharges électrostatiques lorsque vous touchez aux composants, portez une bande antistatique pour poignet et reliez-la à la masse du système (toute surface métallique non peinte du boîtier). 6. Ne faites pas fonctionner le système tandis que le boîtier est ouvert. |
|  | <p>Une fois TOUTES les étapes précédentes accomplies, vous pouvez retirer les panneaux du système. Procédez comme suit:</p> <ol style="list-style-type: none"> 1. Si un cadenas a été installé sur à l'arrière du système, déverrouillez-le et retirez-le. 2. Retirez toutes les vis des panneaux et mettez-les dans un endroit sûr. 3. Retirez les panneaux. |
|  | <p>Afin de permettre le refroidissement et l'aération du système, réinstallez toujours les panneaux du boîtier avant de mettre le système sous tension. Le fonctionnement du système en l'absence des panneaux risque d'endommager ses pièces. Pour installer les panneaux, procédez comme suit:</p> <ol style="list-style-type: none"> 1. Assurez-vous de ne pas avoir oublié d'outils ou de pièces démontées dans le système. 2. Assurez-vous que les câbles, les cartes d'extension et les autres composants sont bien installés. 3. Revissez solidement les panneaux du boîtier avec les vis retirées plus tôt. 4. Remettez le cadenas en place et verrouillez-le afin de prévenir tout accès non autorisé à l'intérieur du système. 5. Rebranchez tous les cordons d'alimentation c. a. et câbles externes au système. |
|  | <p>Le microprocesseur et le dissipateur de chaleur peuvent être chauds si le système a été sous tension. Faites également attention aux broches aiguës des cartes et aux bords tranchants du capot. Nous vous recommandons l'usage de gants de protection.</p> |

| | |
|---|--|
|  | <p>Danger d'explosion si la batterie n'est pas remontée correctement. Remplacer uniquement avec une batterie du même type ou d'un type équivalent recommandé par le fabricant. Disposez des piles usées selon les instructions du fabricant.</p> |
|  | <p>Le système a été conçu pour fonctionner dans un cadre de travail normal. L'emplacement choisi doit être:</p> <ul style="list-style-type: none"> • "Propre et dépourvu de poussière en suspension (sauf la poussière normale). • "Bien aéré et loin des sources de chaleur, y compris du soleil direct. • "A l'abri des chocs et des sources de vibrations. • "Isolé de forts champs électromagnétiques générés par des appareils électriques. • "Dans les régions sujettes aux orages magnétiques il est recommandé de brancher votre système à un supresseur de surtension, et de débrancher toutes les lignes de télécommunications de votre modem durant un orage. • "Muni d'une prise murale correctement mise à la terre. • "Suffisamment spacieux pour vous permettre d'accéder aux câbles d'alimentation (ceux-ci étant le seul moyen de mettre le système hors tension). |

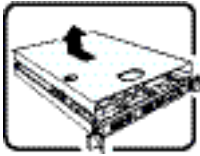
Español

| | |
|---|---|
|  | <p>El usuario debe abstenerse de manipular los componentes de la fuente de alimentación de este producto, cuya reparación debe dejarse exclusivamente en manos de personal técnico especializado. Puede que este producto disponga de más de una fuente de alimentación</p> |
|  | <p>No intente modificar ni usar el cable de alimentación de corriente alterna, si no corresponde exactamente con el tipo requerido. El número de cables suministrados se corresponden con el número de fuentes de alimentación de corriente alterna que tenga el producto</p> |

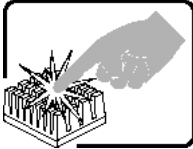
| | |
|---|---|
|  | <p>Nótese que el interruptor activado/desactivado en el panel frontal no desconecta la corriente alterna del sistema. Para desconectarla, deberá desenchufar todos los cables de corriente alterna de la pared o desconectar la fuente de alimentación.</p> |
|  | <p>INSTRUCCIONES DE SEGURIDAD: Cuando extraiga la tapa del chasis para acceder al interior del sistema, siga las siguientes instrucciones:</p> <ol style="list-style-type: none"> 1. Apague todos los dispositivos periféricos conectados al sistema. 2. Apague el sistema presionando el interruptor encendido/apagado. 3. Desconecte todos los cables de alimentación CA del sistema o de las tomas de corriente alterna. 4. Identifique y desconecte todos los cables enchufados a los conectores E/S o a los puertos situados en la parte posterior del sistema. 5. Cuando manipule los componentes, es importante protegerse contra la descarga electrostática (ESD). Puede hacerlo si utiliza una muñequera antiestática sujeta a la toma de tierra del chasis - o a cualquier tipo de superficie de metal sin pintar. 6. No ponga en marcha el sistema si se han extraído las tapas del chasis. |
|  | <p>Después de completar las seis instrucciones de SEGURIDAD mencionadas, ya puede extraer las tapas del sistema. Para ello:</p> <ol style="list-style-type: none"> 1. Desbloquee y extraiga el bloqueo de seguridad de la parte posterior del sistema, si se ha instalado uno. 2. Extraiga y guarde todos los tornillos de las tapas. Extraiga las tapas. |
|  | <p>Para obtener un enfriamiento y un flujo de aire adecuados, reinstale siempre las tapas del chasis antes de poner en marcha el sistema. Si pone en funcionamiento el sistema sin las tapas bien colocadas puede dañar los componentes del sistema. Para instalar las tapas:</p> <ol style="list-style-type: none"> 1. Asegúrese primero de no haber dejado herramientas o componentes sueltos dentro del sistema. 2. Compruebe que los cables, las placas adicionales y otros componentes se hayan instalado correctamente. 3. Incorpore las tapas al chasis mediante los tornillos extraídos anteriormente, tensándolos firmemente. 4. Inserte el bloqueo de seguridad en el sistema y bloquéelo para impedir que pueda accederse al mismo sin autorización. 5. Conecte todos los cables externos y los cables de alimentación CA al sistema. |

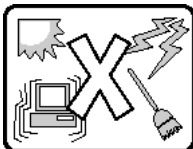
| | |
|---|---|
|  | <p>Si el sistema ha estado en funcionamiento, el microprocesador y el disipador de calor pueden estar aún calientes. También conviene tener en cuenta que en el chasis o en el tablero puede haber piezas cortantes o punzantes. Por ello, se recomienda precaución y el uso de guantes protectores.</p> |
|  | <p>Existe peligro de explosión si la pila no se cambia de forma adecuada. Utilice solamente pilas iguales o del mismo tipo que las recomendadas por el fabricante del equipo. Para deshacerse de las pilas usadas, siga igualmente las instrucciones del fabricante.</p> |
|  | <p>El sistema está diseñado para funcionar en un entorno de trabajo normal. Escoja un lugar:</p> <ul style="list-style-type: none"> • "Limpio y libre de partículas en suspensión (salvo el polvo normal). • "Bien ventilado y alejado de fuentes de calor, incluida la luz solar directa. • "Alejado de fuentes de vibración. • "Aislado de campos electromagnéticos fuertes producidos por dispositivos eléctricos. • "En regiones con frecuentes tormentas eléctricas, se recomienda conectar su sistema a un eliminador de sobrevoltage y desconectar el módem de las líneas de telecomunicación durante las tormentas. • "Provisto de una toma de tierra correctamente instalada. • "Provisto de espacio suficiente como para acceder a los cables de alimentación, ya que éstos hacen de medio principal de desconexión del sistema. |

Italiano

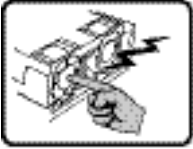
| | |
|---|--|
|  | <p>Rivolgersi ad un tecnico specializzato per la riparazione dei componenti dell'alimentazione di questo prodotto. È possibile che il prodotto disponga di più fonti di alimentazione.</p> |
|---|--|

| | |
|---|--|
|  | <p>Non modificare o utilizzare il cavo di alimentazione in c.a. fornito dal produttore, se non corrisponde esattamente al tipo richiesto. Ad ogni fonte di alimentazione corrisponde un cavo di alimentazione in c.a. separato</p> |
|  | <p>L'interruttore attivato/disattivato nel pannello anteriore non interrompe l'alimentazione in c.a. del sistema. Per interromperla, è necessario scollegare tutti i cavi di alimentazione in c.a. dalle prese a muro o dall'alimentazione di corrente.</p> |
|  | <p>PASSI DI SICUREZZA: Qualora si rimuovano le coperture del telaio per accedere all'interno del sistema, seguire i seguenti passi:</p> <ol style="list-style-type: none"> 1. Spegner tutti i dispositivi periferici collegati al sistema. 2. Spegner il sistema, usando il pulsante spento/acceso dell'interruttore del sistema. 3. Togliere tutte le spine dei cavi del sistema dalle prese elettriche. 4. Identificare e sconnettere tutti i cavi attaccati ai collegamenti I/O od alle prese installate sul retro del sistema. 5. Qualora si tocchino i componenti, proteggersi dallo scarico elettrostatico (SES), portando un cinghia anti-statica da polso che è attaccata alla presa a terra del telaio del sistema - qualsiasi superficie non dipinta - . 6. Non far operare il sistema quando il telaio è senza le coperture. |
|  | <p>Dopo aver seguito i sei passi di SICUREZZA sopracitati, togliere le coperture del telaio del sistema come segue:</p> <ol style="list-style-type: none"> 1. Aprire e rimuovere il lucchetto dal retro del sistema qualora ve ne fosse uno installato. 2. Togliere e mettere in un posto sicuro tutte le viti delle coperture. 3. Togliere le coperture. |
|  | <p>Per il giusto flusso dell'aria e raffreddamento del sistema, rimettere sempre le coperture del telaio prima di riaccendere il sistema. Operare il sistema senza le coperture al loro proprio posto potrebbe danneggiare i componenti del sistema. Per rimettere le coperture del telaio:</p> <ol style="list-style-type: none"> 1. Controllare prima che non si siano lasciati degli attrezzi o dei componenti dentro il sistema. 2. Controllare che i cavi, dei supporti aggiuntivi ed altri componenti siano stati installati appropriatamente. 3. Attaccare le coperture al telaio con le viti tolte in precedenza e avvitarle strettamente. 4. Inserire e chiudere a chiave il lucchetto sul retro del sistema per impedire l'accesso non autorizzato al sistema. 5. Ricollegare tutti i cavi esterni e le prolunghe AC del sistema. |

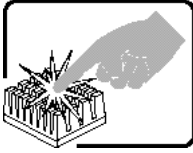
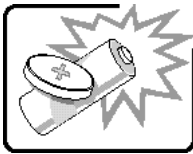
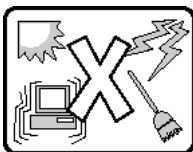
| | |
|---|--|
|  | <p>Se il sistema è stato a lungo in funzione, il microprocessore e il dissipatore di calore potrebbero essere surriscaldati. Fare attenzione alla presenza di piedini appuntiti e parti taglienti sulle schede e sul telaio. È consigliabile l'uso di guanti di protezione.</p> |
|  | <p>Esiste il pericolo di un'esplosione se la pila non viene sostituita in modo corretto. Utilizzare solo pile uguali o di tipo equivalente a quelle consigliate dal produttore. Per disfarsi delle pile usate, seguire le istruzioni del produttore.</p> |
|  | <p>Il sistema è progettato per funzionare in un ambiente di lavoro tipo. Scegliere una postazione che sia:</p> <ul style="list-style-type: none"> • "Pulita e libera da particelle in sospensione (a parte la normale polvere presente nell'ambiente). • "Ben ventilata e lontana da fonti di calore, compresa la luce solare diretta. • "Al riparo da urti e lontana da fonti di vibrazione. • "Isolata dai forti campi magnetici prodotti da dispositivi elettrici. • "In aree soggette a temporali, è consigliabile collegare il sistema ad un limitatore di corrente. In caso di temporali, scollegare le linee di comunicazione dal modem. • "Dotata di una presa a muro correttamente installata. • "Dotata di spazio sufficiente ad accedere ai cavi di alimentazione, i quali rappresentano il mezzo principale di scollegamento del sistema. |

Appendix F: Regulatory and Compliance Information

Product Regulatory Compliance

Warning: *To ensure regulatory compliance, you must adhere to the assembly instructions in this guide to ensure and maintain compliance with existing product certifications and approvals. Use only the described, regulated components specified in this guide. Use of other products/components will void the UL listing and other regulatory approvals of the product and will most likely result in noncompliance with product regulations in the region(s) in which the product is sold.*

To help ensure EMC compliance with your local regional rules and regulations, before computer integration, make sure that the server system, power supply, and other modules have passed EMC testing using a server board with a microprocessor from the same family (or higher) and operating at the same (or higher) speed as the microprocessor used on this server board. The final configuration of your end system product may require additional EMC compliance testing. For more information, please contact your local Intel representative.

This is an FCC Class A device. Integration of it into a Class B system does not result in a Class B device.

Product Safety Compliance

This server chassis product, when correctly integrated per this guide, complies with the following safety and electromagnetic compatibility (EMC) regulations.

Intended Application

This product was evaluated as Information Technology Equipment (ITE), which may be installed in offices, schools, computer rooms, and similar commercial type locations. The suitability of this product for other product categories and environments (such as: medical, industrial, telecommunications, NEBS, residential, alarm systems, test equipment, etc.), other than an ITE application, may require further evaluation.

Product Regulatory Compliance References

The following table references Server Chassis Compliance and markings that may appear on the product. Markings below are typical markings however, may vary or be different based on how certification is obtained.

Note: Certifications Emissions requirements are to Class A.

Table 11. Product Regulatory Compliance Markings



| Compliance Regional Description | Compliance Reference | Compliance Reference Marking Example |
|---------------------------------|--------------------------------------|---|
| Australia / New Zealand | AS/NZS 3548 (Emissions) |  N232 |
| Argentina | IRAM Certification (Safety) |  |
| Belarus | Belarus Certification | None Required |
| Canada / USA | CSA 60950 - UL 60950 (Safety) |  |
| Canada / USA | Industry Canada ICES-003 (Emissions) | CANADA ICES-003 CLASS A CANADA NMB-003 CLASSE A |
| | FCC CFR 47, Part 15 (Emissions) | This device complies with Part 15 of the FCC Rules. Operation of this device is subject to the following two conditions: (1) This device may not cause harmful interference, and (2) This device must accept any interference received, including interference that may cause undesired operation. Manufactured by Intel Corporation |

Table 11. Product Regulatory Compliance Markings





| Compliance Regional Description | Compliance Reference | Compliance Reference Marking Example |
|---------------------------------|---|---|
| CENELEC Europe | Low Voltage Directive 93/68/EEC; EMC Directive 89/336/EEC EN55022 (Emissions) EN55024 (Immunity) EN61000-3-2 (Harmonics) EN61000-3-3 (Voltage Flicker) CE Declaration of Conformity |  |
| Germany | GS Certification - EN60950 |  |
| International | CB Certification - IEC60950 CISPR 22 / CISPR 24 | None Required |
| Japan | VCCI Certification | <p>この装置は、クラス A 情報技術装置です。この装置を家庭環境で使用すると電波妨害を引き起こすことがあります。この場合には使用者が適切な対策を講ずるよう要求されることがあります。VCCI-A</p> |
| Korea | RRL Certification MIC Notice No. 1997-41 (EMC) & 1997-42 (EMI) |  인증번호: CPU |

Table 11. Product Regulatory Compliance Markings

| Compliance Regional Description | Compliance Reference | Compliance Reference Marking Example |
|---------------------------------|---|---|
| Russia | GOST-R Certification GOST R 29216-91 (Emissions) GOST R 50628-95 (Immunity) |  |
| Ukraine | Ukraine Certification | None Required |
| Taiwan | BSMI CNS13438 |  <p>R33025</p> <div style="border: 1px solid black; padding: 2px; width: fit-content;"> <p>警告使用者： 這是甲類的資訊產品，在居住的環境中使用時， 可能會造成射頻干擾，在這種情況下，使用者會 被要求採取某些適當的對策</p> </div> |

Electromagnetic Compatibility Notices

FCC Verification Statement (USA)

This device complies with Part 15 of the FCC Rules. Operation is subject to the following two conditions: (1) this device may not cause harmful interference, and (2) this device must accept any interference received, including interference that may cause undesired operation.

For questions related to the EMC performance of this product, contact:

Intel Corporation
5200 N.E. Elam Young Parkway
Hillsboro, OR 97124-6497
1-800-628-8686

This equipment has been tested and found to comply with the limits for a Class A digital device, pursuant to Part 15 of the FCC Rules. These limits are designed to provide reasonable protection against harmful interference in a residential installation. This equipment generates, uses, and can radiate radio frequency energy and, if not installed and used in accordance with the instructions, may cause harmful interference to radio communications. However, there is no guarantee that interference will not occur in a particular installation. If this equipment does cause harmful interference to radio or television reception, which can be determined by turning the equipment off and on, the user is encouraged to try to correct the interference by one or more of the following measures:

- Reorient or relocate the receiving antenna.
- Increase the separation between the equipment and the receiver.
- Connect the equipment to an outlet on a circuit other than the one to which the receiver is connected.
- Consult the dealer or an experienced radio/TV technician for help.

Any changes or modifications not expressly approved by the grantee of this device could void the user's authority to operate the equipment. The customer is responsible for ensuring compliance of the modified product.

Only peripherals (computer input/output devices, terminals, printers, etc.) that comply with FCC Class A or B limits may be attached to this computer product. Operation with noncompliant peripherals is likely to result in interference to radio and TV reception.

All cables used to connect to peripherals must be shielded and grounded. Operation with cables, connected to peripherals, that are not shielded and grounded may result in interference to radio and TV reception.

Industry Canada (ICES-003)

Cet appareil numérique respecte les limites bruits radioélectriques applicables aux appareils numériques de Classe A prescrites dans la norme sur le matériel brouilleur: "Appareils Numériques", NMB-003 édictée par le Ministre Canadien des Communications.

English translation of the notice above:

This digital apparatus does not exceed the Class A limits for radio noise emissions from digital apparatus set out in the interference-causing equipment standard entitled: "Digital Apparatus," ICES-003 of the Canadian Department of Communications.

Europe (CE Declaration of Conformity)

This product has been tested in accordance to, and complies with the Low Voltage Directive (73/23/EEC) and EMC Directive (89/336/EEC). The product has been marked with the CE Mark to illustrate its compliance.

VCCI (Japan)

この装置は、情報処理装置等電波障害自主規制協議会（VCCI）の基準に基づくクラス A 情報技術装置です。この装置を家庭環境で使用すると電波妨害を引き起こすことがあります。この場合には使用者が適切な対策を講ずるよう要求されることがあります。

English translation of the preceding notice:

This is a Class A product based on the standard of the Voluntary Control Council for Interference (VCCI) from Information Technology Equipment. If this is used near a radio or television receiver in a domestic environment, it may cause radio interference. Install and use the equipment according to the instruction manual.

BSMI (Taiwan)

警告使用者：
這是甲類的資訊產品，在居住的環境中使用時，可能會造成射頻干擾，在這種情況下，使用者會被要求採取某些適當的對策

The BSMI Certification Marking and EMC warning is located on the outside rear area of the product.

Korean Compliance (RRL)

Following is the RRL certification information for Korea.



1. 기기의 명칭(모델명) :
2. 인증번호 :
3. 인증받은 자의 상호 :
4. 제조년월일 :
5. 제조자/제조국가 :



English translation of the notice above:



1. Type of Equipment (Model Name): On License and Product
2. Certification No.: On RRL certificate. Obtain certificate from local Intel representative
3. Name of Certification Recipient: Intel Corporation
4. Date of Manufacturer: Refer to date code on product
5. Manufacturer/Nation: Intel Corporation/Refer to country of origin marked on product

Product Ecology Compliance

Intel has a system in place to restrict the use of banned substances in accordance with world wide product ecology regulatory requirements. The following is Intel's product ecology compliance criteria.

Table 12. Product Ecology Compliance Markings

| Compliance Regional Description | Compliance Reference | Compliance Reference Marking Example |
|--|--|---|
| California | California Code of Regulations, Title 22, Division 4.5; Chapter 33: Best Management Practices for Perchlorate Materials. | Special handling may apply. See www.dtsc.ca.gov/hazardouswaste/perchlorate . This notice is required by California Code of Regulations, Title 22, Division 4.5; Chapter 33: Best Management Practices for Perchlorate Materials. This product / part includes a battery which contains Perchlorate material. |
| China | <p><u>China RoHS</u> Administrative Measures on the Control of Pollution Caused by Electronic Information Products" (EIP) #39. Referred to as China RoHS.</p> <p>Mark requires to be applied to retail products only. Mark used is the Environmental Friendly Use Period (EFUP). Number represents years.</p> |  |
| | <p><u>China Recycling (GB18455-2001)</u> Mark requires to be applied to be retail product only. Marking applied to bulk packaging and single packages. Not applied to internal packaging such as plastics, foams, etc.</p> |  |
| Intel Internal Specification | All materials, parts and subassemblies must not contain restricted materials as defined in Intel's Environmental Product Content Specification of Suppliers and Outsourced Manufacturers - http://supplier.intel.com/ehs/environmental.htm | None Required |
| Europe | Waste Electrical and Electronic Equipment (WEEE) Directive 2002/96/EC - Mark applied to system level products only. |  |

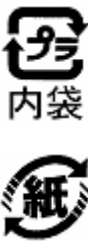
| Compliance Regional Description | Compliance Reference | Compliance Reference Marking Example |
|---------------------------------|---|---|
| Europe | <p>European Directive 2002/95/EC - Restriction of Hazardous Substances (RoHS). Threshold limits and banned substances are noted below.</p> <p>Quantity limit of 0.1% by mass (1000 PPM) for: Lead, Mercury, Hexavalent Chromium, Polybrominated Biphenyls Diphenyl Ethers (PBB/PBDE)</p> <p>Quantity limit of 0.01% by mass (100 PPM) for: Cadmium</p> | None Required. |
| Germany | <p>German Green Dot Applied to Retail Packaging Only for Boxed Boards</p> |  |
| Intel Internal Specification | All materials, parts and subassemblies must not contain restricted materials as defined in Intel's Environmental Product Content Specification of Suppliers and Outsourced Manufacturers - http://supplier.intel.com/ehs/environmental.htm . | None Required |
| International | <p>ISO11469 - Plastic parts weighing >25gm are intended to be marked with per ISO11469.</p> | >PC/ABS< |
| | <p>Recycling Markings - Fiberboard (FB) and Cardboard (CB) are marked with international recycling marks. Applied to outer bulk packaging and single package.</p> |  |
| Japan | <p>Japan Recycling Applied to Retail Packaging Only for Boxed Boards</p> |  |

Other Markings

Table 13. Other Markings

| Compliance Description | Compliance Reference | Compliance Reference Marking Example |
|-------------------------------|--|---|
| Stand-by Power | Stand-by Power Warnings Applied to product if stand-by power switch is used. |  |
| Multiple Power Cords | Multiple Power Cords Warnings Applied to product if more than one power cord is used. | <p>English:</p> <p>This unit has more than one power supply cord. To reduce the risk of electrical shock, disconnect (2) two power supply cords before servicing.</p> <hr/> <p>Simplified Chinese</p> <p>注意： 本设备包括多条电源系统电缆。为避免遭受电击，在进行维修之前应断开两（2）条电源系统电缆</p> <p>Traditional Chinese</p> <p>注意： 本設備包括多條電源系統電纜。為避免遭受電擊，在進行維修之前應斷開兩（2）條電源系統電纜</p> <hr/> <p>German:</p> <p>Dieses Geräte hat mehr als ein Stromkabel. Um eine Gefahr des elektrischen Schlages zu verringern trennen sie beide (2) Stromkabeln bevor Instandhaltung</p> |

| Compliance Description | Compliance Reference | Compliance Reference Marking Example |
|------------------------|----------------------------|--|
| Ground Connection | Ground Connection Warnings | Line1 : "WARNING:" Swedish on line2: "Apparaten skall anslutas till jordat uttag, när den ansluts till ett nätverk." Finnish on line 3: "Laite on liitettävä suojavaadoituskoskettimilla varustettuun pistorasiaan." English on line 4: "Connect only to a properly earth grounded outlet." |

Regulated Specified Components

To maintain the UL listing and compliance to other regulatory certifications and/or declarations, the following regulated components must be used and conditions adhered to. Interchanging or use of other components will void the UL listing and other product certifications and approvals.

Updated product information for configurations can be found on the Intel Server Builder Web site at the following URL: <http://channel.intel.com/go/serverbuilder>

If you do not have access to Intel's Web address, please contact your local Intel representative.

- **Server Chassis:** (base chassis is provided with power supply and fans) - UL listed.
- **Server board:** you must use an Intel server board - UL recognized.
- **Add-in boards:** must have a printed wiring board flammability rating of minimum UL94V-1. Add-in boards containing external power connectors and/or lithium batteries must be UL recognized or UL listed. Any add-in board containing modem telecommunication circuitry must be UL listed. In addition, the modem must have the appropriate telecommunications, safety, and EMC approvals for the region in which it is sold.
- **Peripheral Storage Devices:** must be a UL recognized or UL listed accessory and TUV or VDE licensed. Total server configuration is not to exceed the maximum loading conditions of the power supply.

End-of-Life / Product Recycling

Product recycling and end-of-life take-back systems and requirements vary by country. Contact the retailer or distributor of this product for information about product recycling and / or take-back.

Appendix G: Warranty

Limited Warranty for Intel® Chassis Subassembly Products

Intel warrants that the Products (defined herein as the Intel® chassis subassembly and all of its various components and software delivered with or as part of the Products) to be delivered hereunder, if properly used and installed, will be free from defects in material and workmanship and will substantially conform to Intel's publicly available specifications for a period of three (3) years after the date the Product was purchased from an Intel authorized distributor. Software of any kind delivered with or as part of products is expressly provided "as is" unless specifically provided for otherwise in any software license accompanying the software.

If any Product furnished by Intel which is the subject of this Limited Warranty fails during the warranty period for reasons covered by this Limited Warranty, Intel, at its option, will:

- REPAIR the Product by means of hardware and/or software; OR
- REPLACE the Product with another Product; OR
- REFUND the then-current value of the Product if Intel is unable to repair or replace the Product.

If such Product is defective, transportation charges for the return of Product to buyer within the USA will be paid by Intel. For all other locations, the warranty excludes all costs of shipping, customs clearance, and other related charges. Intel will have a reasonable time to make repairs or to replace Product or to refund the then-current value of the Product.

In no event will Intel be liable for any other costs associated with the replacement or repair of Product, including labor, installation or other costs incurred by buyer and in particular, any costs relating to the removal or replacement of any product soldered or otherwise permanently affixed to any printed circuit board.

This Limited Warranty, and any implied warranties that may exist under state law, apply only to the original purchaser of the Product.

Extent of Limited Warranty

Intel does not warrant that Products to be delivered hereunder, whether delivered stand-alone or integrated with other Products, including without limitation semiconductor components, will be free from design defects or errors known as "errata." Current characterized errata are available upon request.

This Limited Warranty does not cover damages due to external causes, including accident, problems with electrical power, usage not in accordance with product instructions, misuse, neglect, alteration, repair, improper installation, or improper testing.

Warranty Limitations and Exclusions

These warranties replace all other warranties, expressed or implied including, but not limited to, the implied warranties of merchantability and fitness for a particular purpose. Intel makes no expressed warranties beyond those stated here. Intel disclaims all other warranties, expressed or implied including, without limitation, implied warranties of merchantability and fitness for a particular purpose. Some jurisdictions do not allow the exclusion of implied warranties, so this limitation may not apply.

All expressed and implied warranties are limited in duration to the limited warranty period. No warranties apply after that period. Some jurisdictions do not allow limitations on how long an implied warranty lasts, so this limitation may not apply to you.

Limitations of Liability

Intel's responsibility under this, or any other warranty, implied or expressed, is limited to repair, replacement, or refund, as set forth above. These remedies are the sole and exclusive remedies for any breach of warranty. Intel is not responsible for direct, special, incidental, or consequential damages resulting from any breach of warranty under another legal theory including, but not limited to, lost profits, downtime, goodwill, damage to or replacement of equipment and property, and any costs of recovering, reprogramming, or reproducing any program or data stored in or used with a system containing this product. Some jurisdictions do not allow the exclusion or limitation of incidental or consequential damages, so the above limitations or exclusions may not apply to you.

This limited warranty gives you specific legal rights, and you may also have other rights that vary from jurisdiction to jurisdiction.

Any and all disputes arising under or related to this Limited Warranty shall be adjudicated in the following forums and governed by the following laws: for the United States of America, Canada, North America, and South America, the forum shall be Santa Clara, California, USA, and the applicable law shall be that of the State of California, USA; for the Asia Pacific region, the forum shall be Singapore and the applicable law shall be that of Singapore; for Europe and the rest of the world, the forum shall be London and the applicable law shall be that of the United Kingdom.

In the event of any conflict between the English language version and any other translated version(s) of this Limited Warranty, the English language version shall control.

How to Obtain Warranty Service

To obtain warranty service for this Product, you may contact Intel or your authorized distributor.

- North America and Latin America To obtain warranty repair for the product, please go to the following Web site to obtain instructions: <http://support.intel.com/support/motherboards/draform.htm>
- In Europe and in Asia Contact your original authorized distributor for warranty service.

Any replacement Product is warranted under this written warranty and is subject to the same limitations and exclusions for the remainder of the original warranty period.

Telephone Support

If you cannot find the information you need on Intel's World Wide Web site (<http://www.intel.com/>), call your local distributor or an Intel Customer Support representative. See “[Getting Help](#)” for telephone numbers.

Returning a Defective Product

Before returning any product, call your authorized dealer/distribution authority.

