

# Intel® Storage System SSR212CC User Guide

---

**A Guide for Technically Qualified Assemblers of Intel® Identified Subassemblies/  
Products**

Intel Order Number D55418-002

## **Disclaimer**

Information in this document is provided in connection with Intel® products. No license, express or implied, by estoppel or otherwise, to any intellectual property rights is granted by this document. Except as provided in Intel's Terms and Conditions of Sale for such products, Intel assumes no liability whatsoever, and Intel disclaims any express or implied warranty, relating to sale and/or use of Intel® products including liability or warranties relating to fitness for a particular purpose, merchantability, or infringement of any patent, copyright or other intellectual property right. Intel products are not designed, intended or authorized for use in any medical, life saving, or life sustaining applications or for any other application in which the failure of the Intel product could create a situation where personal injury or death may occur. Intel may make changes to specifications and product descriptions at any time, without notice.

Intel® server boards contain a number of high-density VLSI and power delivery components that need adequate airflow for cooling. Intel's own chassis are designed and tested to meet the intended thermal requirements of these components when the fully integrated system is used together. It is the responsibility of the system integrator that chooses not to use Intel developed server building blocks to consult vendor datasheets and operating parameters to determine the amount of airflow required for their specific application and environmental conditions. Intel Corporation can not be held responsible if components fail or the server board does not operate correctly when used outside any of their published operating or non-operating limits.

Intel, Intel Pentium, and Intel Xeon are trademarks or registered trademarks of Intel Corporation or its subsidiaries in the United States and other countries.

\* Other names and brands may be claimed as the property of others.

Copyright © 2006, Intel Corporation. All Rights Reserved

# Safety Information

---

## Important Safety Instructions

Read all caution and safety statements in this document before performing any of the instructions. See also Intel Server Boards and Server Chassis Safety Information on the *Intel® Server Deployment Toolkit CD* and/or at <http://support.intel.com/support/motherboards/server/sb/cs-010770.htm>.

## Wichtige Sicherheitshinweise

Lesen Sie zunächst sämtliche Warnung und Sicherheitshinweise in diesem Dokument, bevor Sie eine der Anweisungen ausführen. Beachten Sie hierzu auch die Sicherheitshinweise zu Intel-Serverplatinen und Servergehäusen auf der *Intel® Server Deployment Toolkit CD* oder unter <http://support.intel.com/support/motherboards/server/sb/cs-010770.htm>.

## Consignes de sécurité

Lisez attention toutes les consignes de sécurité et les mises en garde indiquées dans ce document avant de suivre toute instruction. Consultez Intel Server Boards and Server Chassis Safety Information sur le *Intel® Server Deployment Toolkit CD* ou bien rendez-vous sur le site <http://support.intel.com/support/motherboards/server/sb/cs-010770.htm>.

## Instrucciones de seguridad importantes

Lea todas las declaraciones de seguridad y precaución de este documento antes de realizar cualquiera de las instrucciones. Vea Intel Server Boards and Server Chassis Safety Information en el *Intel® Server Deployment Toolkit CD* y/o en <http://support.intel.com/support/motherboards/server/sb/cs-010770.htm>.

## 重要安全指导

在执行任何指令之前，请阅读本文档中的所有注意事项及安全声明。和/或 <http://support.intel.com/support/motherboards/server/sb/cs-010770.htm> 上的 *Intel Server Boards and Server Chassis Safety Information* (《Intel 服务器主板与服务器机箱安全信息》)。

## Warnings

**Heed safety instructions:** Before working with your server product, whether you are using this guide or any other resource as a reference, pay close attention to the safety instructions. You must adhere to the assembly instructions in this guide to ensure and maintain compliance with existing product certifications and approvals. Use only the described, regulated components specified in this guide. Use of other products / components will void the UL listing and other regulatory approvals of the product and will most likely result in noncompliance with product regulations in the region(s) in which the product is sold.

**System power on/off:** The power button DOES NOT turn off the system AC power. To remove power from system, you must unplug the AC power cord from the wall outlet. Make sure the AC power cord is unplugged before you open the chassis, add, or remove any components.

**Hazardous conditions, devices and cables:** Hazardous electrical conditions may be present on power, telephone, and communication cables. Turn off the server and disconnect the power cord, telecommunications systems, networks, and modems attached to the server before opening it. Otherwise, personal injury or equipment damage can result.

**Electrostatic discharge (ESD) and ESD protection:** ESD can damage disk drives, boards, and other parts. We recommend that you perform all procedures in this chapter only at an ESD workstation. If one is not available, provide some ESD protection by wearing an antistatic wrist strap attached to chassis ground any unpainted metal surface on your server when handling parts.

**ESD and handling boards:** Always handle boards carefully. They can be extremely sensitive to ESD. Hold boards only by their edges. After removing a board from its protective wrapper or from the server, place the board component side up on a grounded, static free surface. Use a conductive foam pad if available but not the board wrapper. Do not slide board over any surface.

**Installing or removing jumpers:** A jumper is a small plastic encased conductor that slips over two jumper pins. Some jumpers have a small tab on top that you can grip with your fingertips or with a pair of fine needle nosed pliers. If your jumpers do not have such a tab, take care when using needle nosed pliers to remove or install a jumper; grip the narrow sides of the jumper with the pliers, never the wide sides. Gripping the wide sides can damage the contacts inside the jumper, causing intermittent problems with the function controlled by that jumper. Take care to grip with, but not squeeze, the pliers or other tool you use to remove a jumper, or you may bend or break the pins on the board.

# Preface

---

## About this Manual

Thank you for purchasing and using the Intel® Storage System SSR212CC.

This manual is written for system technicians who are responsible for troubleshooting, upgrading, and repairing this storage system. This document provides a brief overview of the features of the product, a list of accessories or other components you may need, troubleshooting information, and instructions on how to add and replace components on the Intel® Storage System SSR212CC. For the latest version of this manual, see <http://support.intel.com/support/motherboards/server/ssr212cc/>.

## Manual Organization

Chapter 1 provides a brief overview of the Intel® Storage System SSR212CC. In this chapter, you will find a list of the storage system's features, photos of the product, and product diagrams to help you identify components and their locations.

Chapter 2 provides instructions on adding and replacing components. Use this chapter for step-by-step instructions and diagrams for installing or replacing components such as the fans, power supply, drives, and other components.

At the back of this book, you will find technical specifications, regulatory information, safety information, "getting help" information, and warranty information.

## Product Contents, Order Options, and Accessories

This storage system is compatible with the following Intel® Server Boards:

- Intel® Server Board SE7520JR2

Your Intel® Storage System SSR212CC ships with the following items:

- Intel® Storage System SSR212CC
- Attention document, in the product box
- *Intel® Storage System SSR212CC Quick Start User's Guide*, in the product box
- AC power cord (North America only)
- 50 Phillips\* head screws
- Resource CD
- Rail kit
- T10 TORX\* screwdriver

- RJ-45 serial cable

In addition, you may need or want to purchase one or more of the following accessory items for your server:

Memory DIMMs, and hard drives.

For information about which accessories, memory, processors, and third-party hardware have been tested and can be used with your storage system, and for ordering information for Intel® products, see <http://support.intel.com/support/motherboards/server/ssr212cc/compat.htm>.

## Additional Information and Software

If you need more information about this product or information about the accessories that can be used with this storage system, use the following resources. These files are available at <http://support.intel.com/support/motherboards/server/ssr212cc/>. Unless otherwise indicated in the following table, once on this Web page, type the document or software name in the search field at the left side of the screen and select the option to search "This Product."

<b>For this information or software</b>	<b>Use this Document or Software</b>
For in-depth technical information about this product, including BIOS settings and chipset information	<i>Intel® Storage System SSR212CC Technical Product Specification</i>
If you just received this product and need to install it	<i>Intel® Storage System SSR212CC Quick Start User's Guide</i> in the product box
For virtual system tours and interactive repair information	A link to the SMaRT Tool is available under "Other Resources" at the right side of the screen at <a href="http://support.intel.com/support/motherboards/server/ssr212cc/">http://support.intel.com/support/motherboards/server/ssr212cc/</a>
Accessories or other Intel server products	Spares and Configuration Guide
Hardware (peripheral boards, adapter cards) and operating systems that have been tested with this product	Tested Hardware Operating Systems List
To make sure your system falls within the allowed power budget	Power Budget Tool
For software to manage your Intel® server	Intel® Server Management Software
For diagnostics test software	Diagnostics

# Contents

---

<b>Safety Information</b> .....	<b>iii</b>
Important Safety Instructions .....	iii
Wichtige Sicherheitshinweise .....	iii
Consignes de sécurité .....	iii
Instrucciones de seguridad importantes .....	iii
Warnings.....	iv
<b>Preface</b> .....	<b>v</b>
About this Manual .....	v
Manual Organization .....	v
Product Contents, Order Options, and Accessories .....	v
Additional Information and Software .....	vi
<b>Storage System Features</b> .....	<b>1</b>
The Enclosure Core Product .....	2
Enclosure Chassis .....	4
Server Board Sub-system .....	5
Power Supply Module .....	5
Multiple Power Supply Modules .....	6
Power Supply Output Cables .....	7
Cooling Module .....	7
Drive Carrier .....	8
Drive LED Indicators .....	8
Blanking Plates .....	9
Front Panel .....	9
Spare Parts and Accessories .....	10
<b>Hardware Installations and Upgrades</b> .....	<b>11</b>
Before You Begin .....	11
Tools and Supplies Needed .....	11
System References .....	11
Planning Your Installation .....	11
Drive Bay Numbering Convention .....	12
Installing the Enclosure in a Rack System.....	13
Rack System Precautions .....	13
Rack Mount Rail Kit .....	14
Removing or Installing the Enclosure Cover .....	14
Removing the Enclosure Cover .....	14
Installing the Enclosure Cover .....	16
Removing or Installing a Power Supply Module .....	17
Removing a Power Supply Module.....	18

## Contents

Installing a Power Supply Module .....	19
Connecting the Power Cord(s) .....	21
Grounding Checks .....	22
Removing or Installing the PCI Riser Assembly .....	22
Blanking Plates .....	22
Removing the PCI Riser Assembly .....	22
Installing the PCI Riser Assembly .....	25
Replacing a PCI Riser Connector Card .....	28
Removing and Installing an Intel® RAID Controller .....	30
Removing an Intel® RAID Controller .....	30
Installing an Intel® RAID Controller .....	33
Replacing the Battery for an Intel® RAID Controller .....	37
Installing a PCI Card .....	43
Hot Swap Replacing, Removing or Installing the Cooling Module .....	47
Hot Swap Replacing the Cooling Module .....	47
Removing the Cooling Module .....	51
Installing the Cooling Module .....	54
Replacing the Fan Interposer Board .....	57
Removing or Installing a Drive Carrier .....	62
Planning Your Drive Carrier Configuration .....	62
Removing a Drive Carrier .....	62
Installing a Drive Carrier .....	63
Removing or Installing a Hard Drive into a Drive Carrier .....	65
Removing a Hard Drive from a Drive Carrier .....	65
Installing a Hard Drive into a Drive Carrier .....	66
Replacing an Intel® Server Board SE7520JR2 .....	67
Removing a Server Board .....	67
Installing a Server Board .....	70
Removing or Installing the Processor Air Duct .....	72
Removing the Processor Air Duct .....	72
Installing the Processor Air Duct .....	73
Removing or Installing the Processor .....	74
Removing the Processor .....	74
Installing the Processor .....	76
Replacing a Chassis (FXCCHASSIS) .....	79
Replacing the Server Board Battery .....	85
Removing or Installing Memory .....	89
Memory Requirements .....	89
Removing DIMMs .....	91
Installing DIMMs .....	93
Removing or Installing the Intel® Management Module Professional (IMM Pro) Module ...	94
Removing the IMM Pro Module .....	94
Installing the IMM Pro Module .....	98
<b>Operation .....</b>	<b>103</b>



Before You Begin .....	103
Power On .....	103
Power Supply Module LED .....	103
Front Panel LEDs .....	104
Rear Panel Buttons .....	105
Starting the Drives .....	105
Disk Drives LEDs .....	105
Power Down .....	105
<b>Troubleshooting and Problem Solving .....</b>	<b>107</b>
Overview .....	107
Initial Start-up Problems .....	107
LEDs .....	107
Power Supply Units .....	107
Front Panel .....	108
Troubleshooting .....	108
Power Supply Module Faults .....	109
Thermal Control .....	109
Thermal Alarm .....	110
Thermal Shutdown .....	110
Drive Carrier Module Faults.....	111
Blank Drive Carriers .....	111
Dealing with Hardware Faults .....	111
<b>Technical Specifications .....</b>	<b>113</b>
Dimensions .....	113
Weight .....	113
AC Power Module (1 or 2 500-W Power Supply Units) .....	113
Power Supply Safety and EMC Compliance .....	114
Power Cord .....	114
Cooling Module.....	115
Environment .....	115
Drive Carrier Specification .....	116
<b>A Intel® Server Board SE7520JR2 BIOS Settings .....</b>	<b>117</b>
<b>B RAID Levels .....</b>	<b>119</b>
RAID 0 - Data Striping .....	119
RAID 1 - Disk Mirroring / Disk Duplexing.....	120
RAID 5 - Data Striping with Striped Parity .....	120
RAID 10 - Combination of RAID 1 and RAID 0 .....	121
RAID 50 - Combination of RAID 5 and RAID 0.....	122
<b>C Upgrading Component Firmware .....</b>	<b>123</b>
Upgrading Component Firmware or the Server Board BIOS .....	123
<b>D Safety Information .....</b>	<b>125</b>

## Contents

English .....	125
Server Safety Information .....	125
Safety Warnings and Cautions .....	125
Intended Application Uses .....	126
Site Selection .....	126
Equipment Handling Practices .....	126
Power and Electrical Warnings .....	126
System Access Warnings .....	127
Rack Mount Warnings .....	128
Electrostatic Discharge (ESD) .....	128
Other Hazards .....	129
Deutsch .....	130
Sicherheitshinweise für den Server .....	130
Sicherheitshinweise und Vorsichtsmaßnahmen .....	130
Zielbenutzer der Anwendung .....	131
Standortauswahl .....	131
Handhabung von Geräten .....	131
Warnhinweise für den Systemzugang .....	133
Elektrostatische Entladungen (ESD) .....	134
Andere Gefahren .....	135
Français .....	136
Consignes de sécurité sur le serveur .....	136
Sécurité: avertissements et mises en garde .....	136
Domaines d'utilisation prévus .....	137
Sélection d'un emplacement .....	137
Pratiques de manipulation de l'équipement .....	137
Décharges électrostatiques (ESD) .....	140
Autres risques .....	141
Español .....	142
Información de seguridad del servidor .....	142
Advertencias y precauciones sobre seguridad .....	142
Aplicaciones y usos previstos .....	143
Selección de la ubicación .....	143
Manipulación del equipo .....	143
Advertencias el acceso al sistema .....	145
Descarga electrostática (ESD) .....	146
<b>E Intel® Server Issue Report Form .....</b>	<b>153</b>
<b>F Getting Help .....</b>	<b>157</b>
World Wide Web .....	157
Telephone .....	157
U.S. and Canada .....	157
Europe .....	157
In Asia-Pacific region .....	158
Japan .....	158
Latin America .....	158

<b>G Regulatory and Compliance Information .....</b>	<b>161</b>
Product Regulatory Compliance .....	161
Product Safety Compliance .....	161
Product EMC Compliance - Class A Compliance .....	162
Certifications / Registrations / Declarations .....	162
Product Regulatory Compliance Markings .....	163
Electromagnetic Compatibility Notices .....	164
FCC Verification Statement (USA) .....	164
Industry Canada (ICES-003) .....	165
Europe (CE Declaration of Conformity) .....	165
VCCI (Japan) .....	165
BSMI (Taiwan) .....	166
Korean Compliance (RRL) .....	166
Regulated Specified Components .....	166
End of Life / Product Recycling .....	167
<b>H Installation/Assembly Safety Instructions .....</b>	<b>169</b>
English .....	169
Deutsch .....	171
Français .....	174
Español .....	176
Italiano .....	178
<b>I Warranty .....</b>	<b>181</b>
Limited Warranty for Intel® Chassis Subassembly Products .....	181
Extent of Limited Warranty .....	181
Warranty Limitations and Exclusions .....	182
Limitations of Liability .....	182
How to Obtain Warranty Service .....	182
Telephone Support .....	183
Returning a Defective Product .....	183

*Contents*

# List of Figures

---

Figure 1. Intel® Storage System SSR212CC - Front View .....	1
Figure 2. Intel® Storage System SSR212CC - Rear View Showing Service Areas.....	2
Figure 3. Rear Isometric View.....	3
Figure 4. Front Isometric View .....	4
Figure 5. Storage System Chassis.....	5
Figure 6. Power Supply Module .....	6
Figure 7. System With One Power Supply Module Fitted .....	6
Figure 8. Cooling Module .....	7
Figure 9. Empty Drive Carrier.....	8
Figure 10. Front Panel.....	9
Figure 11. Drive Bay Numbering .....	12
Figure 12. Unlatching Enclosure Cover.....	15
Figure 13. Removing Enclosure Cover .....	16
Figure 14. Installing Enclosure Cover .....	17
Figure 15. Unlatching a Power Supply Module .....	18
Figure 16. Removing a Power Supply Module .....	19
Figure 17. Removing Blanking Plate .....	20
Figure 18. Inserting Power Supply Module .....	20
Figure 19. Connecting Power Cords .....	21
Figure 20. Disconnecting First SATA Cable.....	23
Figure 21. Disconnecting Main Power (P1) Cable from Server Board .....	23
Figure 22. Disconnecting Remaining Two SATA Cables .....	24
Figure 23. Removing PCI Riser Assembly from Chassis .....	24
Figure 24. Installing PCI Riser Assembly into Chassis .....	25
Figure 25. Connecting First Two SATA Cables.....	26
Figure 26. Connecting Main Power Cable.....	26
Figure 27. Connecting Third SATA Cable to Server Board.....	27
Figure 28. Removing PCI Riser Connector Card from PCI Riser Assembly .....	28
Figure 29. Securing PCI Riser Connector Card to PCI Riser Assembly .....	29
Figure 30. Disconnecting SATA Cables .....	31
Figure 31. Removing Intel® RAID Controller from PCI Riser Assembly.....	31
Figure 32. Removing Battery Backup Unit .....	32
Figure 33. Connecting Extended Battery Cable to Battery Backup Unit .....	33
Figure 34. Attaching Battery Backup Unit to Intel® RAID Controller .....	34
Figure 35. Installing Intel® RAID Controller .....	35
Figure 36. Attaching Extended Battery Cable to Battery.....	35
Figure 37. Attach SATA Cables .....	36
Figure 38. Disconnecting Battery Cable from New Battery Backup Unit.....	37
Figure 39. Detaching Battery from New Battery Backup Unit .....	37
Figure 40. Removing Battery Holder from PCI Riser Assembly.....	38
Figure 41. Removing Old Battery from Battery Holder.....	38
Figure 42. Securing New Battery to Battery Holder .....	39

## List of Figures

Figure 43. Re-attaching Battery Holder to PCI Riser Assembly .....	40
Figure 44. Detaching Bad Battery Backup Unit from Intel® RAID Controller .....	41
Figure 45. Disconnecting Extended Battery Cable from Battery Backup Unit .....	41
Figure 46. Connecting Battery Cable to New Battery Backup Unit.....	42
Figure 47. Attaching New Battery Backup Unit to Intel® RAID Controller.....	42
Figure 48. Removing PCI Riser Assembly from Chassis.....	43
Figure 49. Removing PCI Slot Filler.....	44
Figure 50. Installing PCI Card into PCI Riser Assembly .....	45
Figure 51. Installing PCI Riser Assembly into Chassis .....	46
Figure 52. Accessing the Cooling Module .....	47
Figure 53. Opening Cooling Module Latches.....	48
Figure 54. Cooling Module with Latches in Open Position .....	48
Figure 55. Unlatching Cooling Module from Chassis.....	49
Figure 56. Removing Cooling Module from Chassis.....	49
Figure 57. Installing the Cooling Module.....	50
Figure 58. Latching Cooling Module into Chassis.....	50
Figure 59. Closing Enclosure Cover .....	51
Figure 60. Accessing the Cooling Module .....	52
Figure 61. Unlatching Cooling Module.....	53
Figure 62. Removing Cooling Module.....	53
Figure 63. Accessing the Cooling Module .....	54
Figure 64. Opening Cooling Module Latches.....	55
Figure 65. Cooling Module with Latches in Open Position .....	55
Figure 66. Inserting Cooling Module into Chassis .....	56
Figure 67. Closing Latches on Cooling Module .....	56
Figure 68. Disconnecting IPMB Cable from Fan Interposer Board.....	58
Figure 69. Removing Fan Interposer Board from Chassis.....	59
Figure 70. Securing Fan Interposer Board to Chassis.....	60
Figure 71. Connecting IPMB Cable to Fan Interposer Board .....	61
Figure 72. Releasing Screw from Front of Drive Carrier.....	62
Figure 73. Removing Drive Carrier from Drive Bay .....	63
Figure 74. Installing Drive Carrier into Drive Bay.....	64
Figure 75. Removing Hard Drive from Drive Carrier.....	65
Figure 76. Installing Hard Drive in Drive Carrier .....	66
Figure 77. Disconnecting Cables from Server Board.....	68
Figure 78. Removing Server Board from Chassis .....	69
Figure 79. Installing Server Board in Chassis.....	70
Figure 80. Connecting Cables to Server Board .....	71
Figure 81. Removing Processor Air Duct.....	72
Figure 82. Installing Processor Air Duct.....	73
Figure 83. Removing Heatsink.....	75
Figure 84. Opening Socket Lever .....	75
Figure 85. Removing Processor .....	76
Figure 86. Opening Socket Lever .....	77
Figure 87. Inserting Processor.....	77
Figure 88. Closing Socket Lever.....	78
Figure 89. Installing the Heatsink.....	78

Figure 90. Disconnecting Cables from Server Board .....	80
Figure 91. Installing Server Board in Chassis .....	81
Figure 92. Drive Bay Numbering Order .....	81
Figure 93. Installing Server Board in Chassis .....	82
Figure 94. Connecting Cables to Server Board.....	83
Figure 95. Connecting P4 Power Supply Cable to Backplane .....	84
Figure 96. Drive Bay Numbering Order.....	84
Figure 97. Removing PCI Riser Assembly from Chassis .....	86
Figure 98. Removing Server Board Battery .....	87
Figure 99. Installing PCI Riser Assembly into Chassis .....	88
Figure 100. DIMM Identification .....	89
Figure 101. Removing Memory.....	92
Figure 102. Installing Memory.....	93
Figure 103. Removing PCI Riser Assembly from Chassis .....	95
Figure 104. Removing IMM Pro Module from Server Board .....	96
Figure 105. Installing PCI Riser Assembly into Chassis .....	97
Figure 106. Removing PCI Riser Assembly from Chassis .....	99
Figure 107. Securing IMM Pro Module Stand-off to Server Board.....	99
Figure 108. Installing IMM Pro Module to Server Board .....	100
Figure 109. Installing PCI Riser Assembly into Chassis .....	101
Figure 110. Front Panel LEDs.....	108
Figure 111. RAID 0 - Data Striping.....	119
Figure 112. RAID 1 - Disk Mirroring / Disk Duplexing .....	120
Figure 113. RAID 5 - Data Striping with Striped Parity.....	120
Figure 114. RAID 10 - Combination of RAID 1 and RAID 0 .....	121
Figure 115. RAID 50 - Combination of RAID 5 and RAID 0 .....	122

*List of Figures*



# List of Tables

---

Table 1. Front Panel Descriptions .....	10
Table 2. Spare Parts and Accessories .....	10
Table 3. Configuration Requirements.....	12
Table 4. DIMM Module Memory Capacity Support .....	90
Table 5. Power Supply Module LED Indicators.....	103
Table 6. Front Panel LED Indicators .....	104
Table 7. Rear Panel Button Functions .....	105
Table 8. Front Panel LED States.....	108
Table 9. Drive Fault LED Functions .....	111
Table 10. Intel® Server Board SE7520JR2 BIOS Settings.....	117

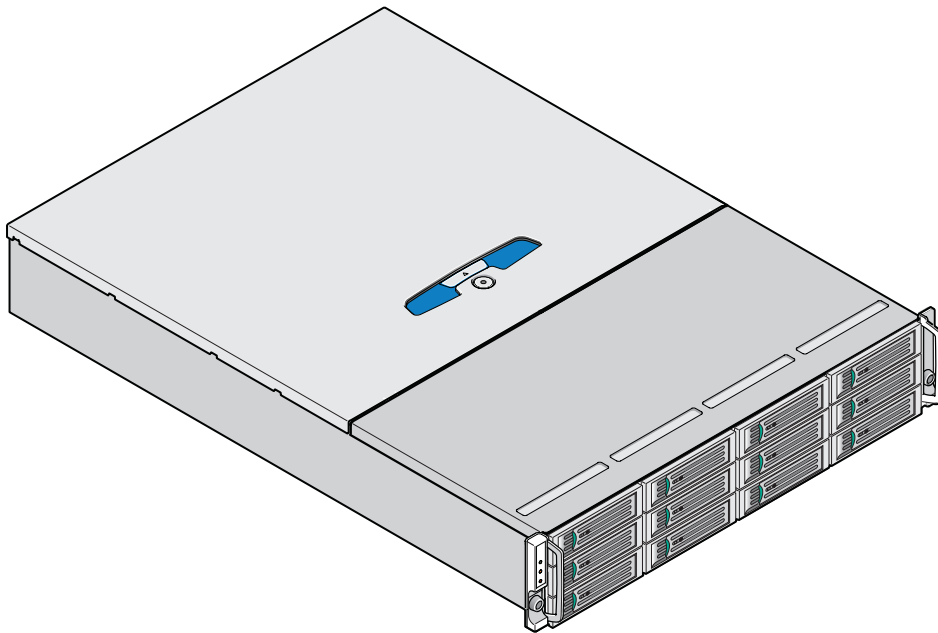
*List of Tables*

# 1 Storage System Features

---

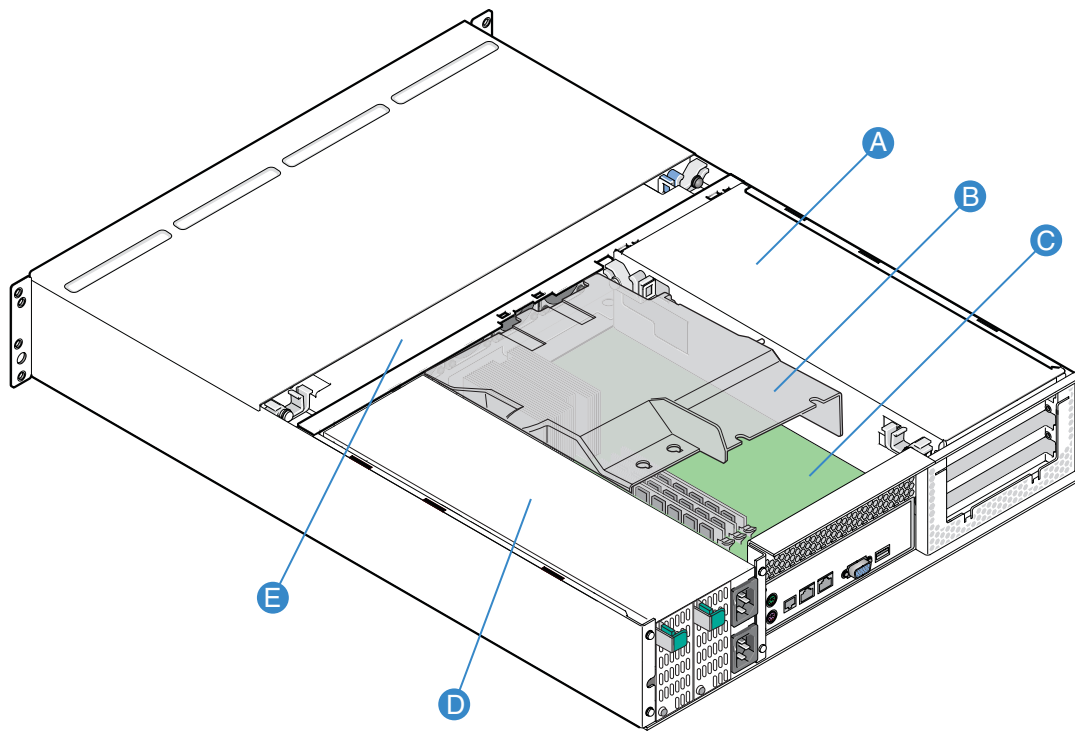
The Intel® Storage System SSR212CC is a 2U (rack space) disk drive enclosure, currently housing twelve low-profile (1-in high), 3.5-in form factor SATA disk drives.

Figure 1 shows a front view of the Intel® Storage System SSR212CC while Figure 2 depicts a rear view with the lid removed, showing those areas accessible to *service personnel only*.



TP01828

**Figure 1. Intel® Storage System SSR212CC - Front View**



TP01857

**Figure 2. Intel® Storage System SSR212CC - Rear View Showing Service Areas**

A. Riser Card Assembly
B. Processor Air Duct
C. Server Board
D. Power Supply Cage
E. Cooling Module

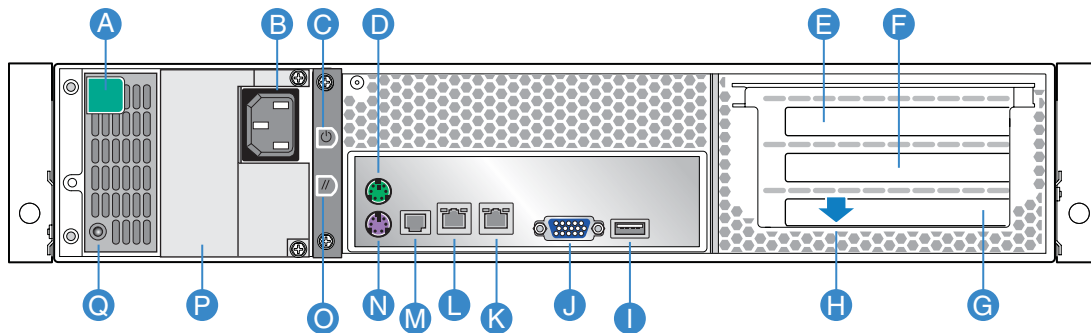
## The Enclosure Core Product

The Intel® Storage System SSR212CC design concept is based on a sub-system together with a set of plug-in modules and (*as supplied*) comprises:

- An enclosure chassis with backplane
- A server sub-system comprising:
  - An Intel® Server Board SE7520JR2
  - A PCI Riser card assembly
  - Two Intel® RAID Controller SRCS28X cards
- A power supply cage containing one AC, 500-W plug-in power supply unit

- A cooling module, comprising three high-speed dual-rotor axial fans and two single-rotor axial fans
- 12 serial ATA (SATA) drive carrier modules (must be fitted in all unused drive bays)

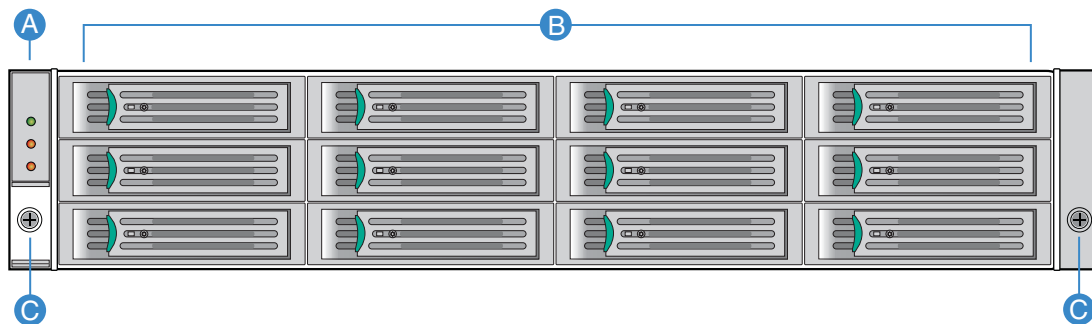
Module and major component locations are shown in Figure 2.



TP01824

**Figure 3. Rear Isometric View**

A.	Power Supply Modules
B.	Primary A/C Power Connector
C.	Power Button
D.	PS2 Mouse Port
E.	Intel® RAID Controller SRCS28X
F.	Intel® RAID Controller SRCS28X
G.	Empty slot
H.	ID LED
I.	USB Port
J.	Video Port
K.	NIC2 Port (1 GB)
L.	NIC1 Port (1 GB)
M.	Serial Port
N.	PS2 Keyboard Port
O.	Reset Button
P.	Blanking Plate
Q.	Power Supply Module Indicator LED



TP01823

**Figure 4. Front Isometric View**

- |                         |
|-------------------------|
| A. Front Panel          |
| B. Drive Bays           |
| C. Rack Retaining Screw |

## Enclosure Chassis

The chassis consists of a sheet metal enclosure assembly containing an integrated backplane printed circuit board.

The chassis is fitted with 19-in rack-mounting features, which enables it to be fitted to standard 19-in racks, and uses two EIA units of rack space (*i.e.*, 3.5 in high).

The backplane printed circuit board provides 12 direct dock serial ATA connectors to the drives and acts as the connectivity hub of the enclosure, connecting to the power supply enclosure, cooling module, server board and serial ATA controller.

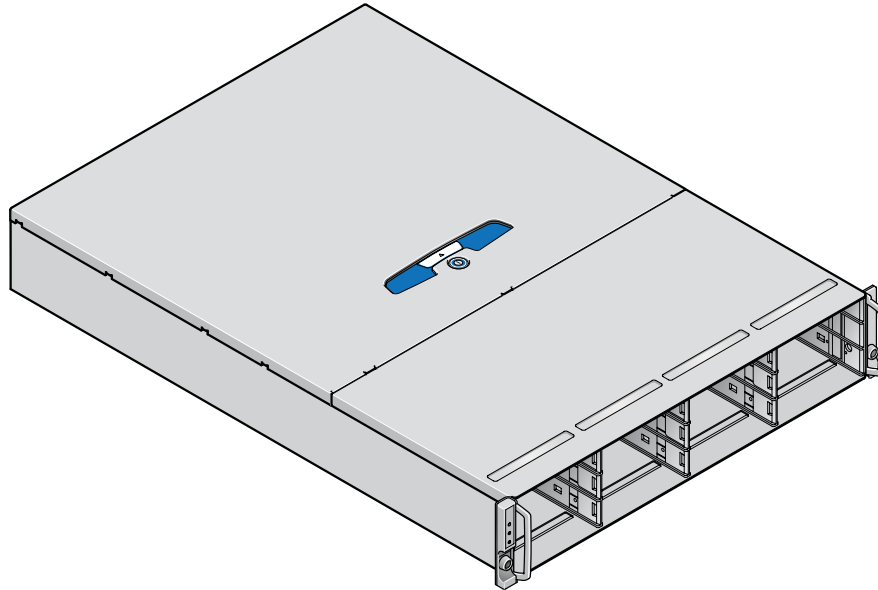
There are 12 drive bays at the front of the enclosure. Each drive bay accommodates a plug-in drive carrier that houses low-profile (1-in) high 3.5-in form factor drives.

**Note:** A bay is defined as the space required to house a single 1.0-in high 3.5-in SATA disk drive in its carrier module.

At the rear, the chassis assembly accommodates a power supply cage, a server board, and a PCI riser card assembly.

A cover on the enclosure provides access to the cooling module and the server board sub-system.

**Important:** The cover should only be removed by service personnel as it provides access to a service area. Upon replacement, the cover **MUST** be secured by tightening the lock with a screwdriver.



TP01834

**Figure 5. Storage System Chassis**

## Server Board Sub-system

The server board sub-system consists of:

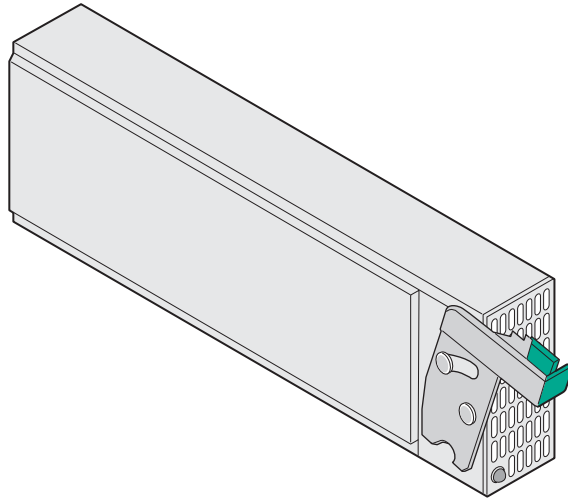
- An Intel® Server Board SE7520JR2 with a single low-voltage Intel® Xeon® processor
- An Intel® Management Module Professional
- Two Intel® RAID Controller SRCS28X cards
- Dual Intel® 10/100/1000 LAN ports

## Power Supply Module

The Intel® Storage System SSR212CC ships with one 500-W power supply module. A second 500-W power supply module can be ordered optionally as an accessory. Each power supply module comes with its own IEC inlet connector and failure indicator.

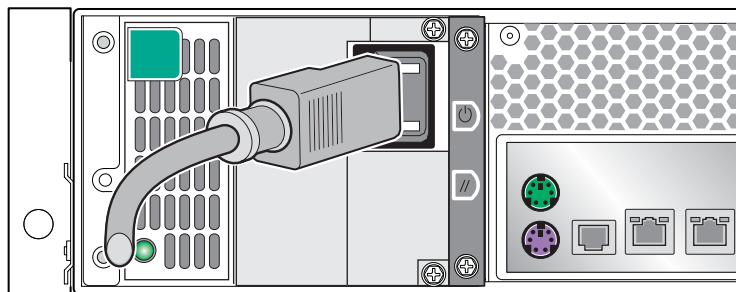
The power supply enclosure is mounted in the rear of the chassis as part of the sub-system core product

**Important:** If only one power supply module is fitted, it must be installed in the lefthand slot with the top AC input socket used for connection to the power source. A blanking plate must be fitted to cover the empty righthand slot and the unused (lower) AC input socket. Operation of the storage system with ANY modules missing will disrupt the airflow, and the drives will not receive sufficient cooling. It is **ESSENTIAL** that all apertures are filled before operating the system.



TP01844

**Figure 6. Power Supply Module**



TP01772

**Figure 7. System With One Power Supply Module Fitted**

Power supply module voltage operating ranges are nominally 100V - 240V AC, selected automatically. A typical power supply module is shown in Figure 6.

## Multiple Power Supply Modules

The Intel® Storage System SSR212CC can be operated with one or two power supply modules fitted in the power supply enclosure, providing dual-power sources for the system so that if one power supply module fails the other maintains the power supply and enclosure operation is not affected while the faulty unit is replaced.



Power supply module replacement must be completed within 30 seconds of removal of the failed power supply module.

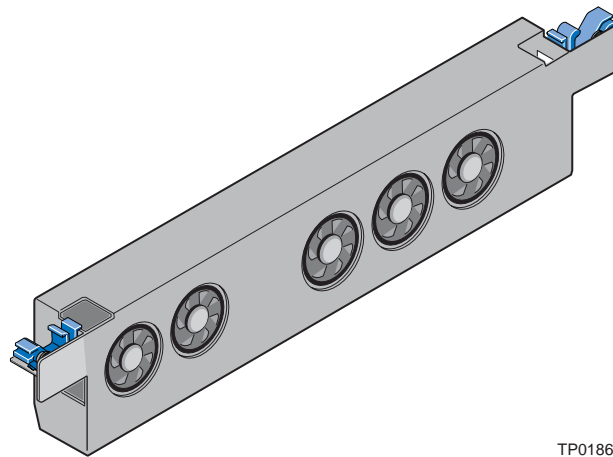
## Power Supply Output Cables

The power supply output cables provide the following outputs:

- Backplane power connector, including Power Good and Power Fail
- Server board power connectors (1 x 24 pin, 1 x 8 pin)
- 1 x 4-pin power sockets for internal peripheral power (*not used*)
- 1 x 5 power signal cable

## Cooling Module

The cooling module consists of three high-speed dual-rotor axial fans and two single-rotor axial fans, mounted in a common frame for ease of maintenance. The fans are mounted in a single fan tray in the center of the enclosure; this ensures maximum airflow through the power supply unit and minimizes noise. The single interface to the cooling module provides power and speed control to the fans and returns tacho output from each fan.



TP01862

**Figure 8. Cooling Module**

Airflow is front to rear with cooling air being drawn across the drives, through the fans and pressurizing the rear of the enclosure. The pressurized rear allows the power supply unit to draw the air that it requires, and perforations at the rear of the chassis allow cooling airflow over the processor heatsinks, server board and PCI cards.

The cooling system must be operated with low-pressure rear exhaust installation [Back pressure created by rack doors and obstacles not to exceed 5 pascals (0.5-mm water gauge)].

The cooling system provides sufficient capacity to ensure that drive maximum temperatures are not exceeded at 35°C ambient with one fan failed at 7,000 ft.

## Drive Carrier

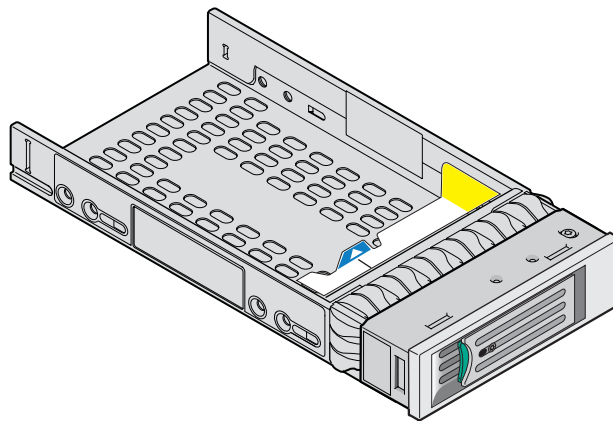
Drive carriers are provided for fitting in all unused drive bays. They are designed as integral drive carrier front caps with handles and must be fitted to all unused drive bays to maintain a balanced airflow. The removable air baffle labels in empty drive carriers must be removed upon installation of a hard drive.

The drive carrier comprises a hard disk mounted in a carrier. Each drive bay will house a single low-profile 1.0-in high, 3.5-in form factor SATA disk drive in its drive carrier. The drive carrier has mounting locations for SATA drives.

Each disk drive is enclosed in a sheet steel carrier, which provides excellent thermal conduction, radio frequency and electro-magnetic induction protection and affords the drive maximum physical protection. A TORX\* screw secures the drive carrier to the drive bay to prevent accidental removal.

The front cap also supports an ergonomic handle, which provides the following functions:

- Spring loading of drive carrier into and out of drive bays
- Positive “spring loading” of the drive/backplane connector.



TP01843

**Figure 9. Empty Drive Carrier**

## Drive LED Indicators

Each drive carrier incorporates a green Drive Status LED and an amber Drive Fault LED.

LED	Definition
Drive Status LED	Flashes green as drive operates
Drive Fault LED	Continuous amber light indicates a failure condition

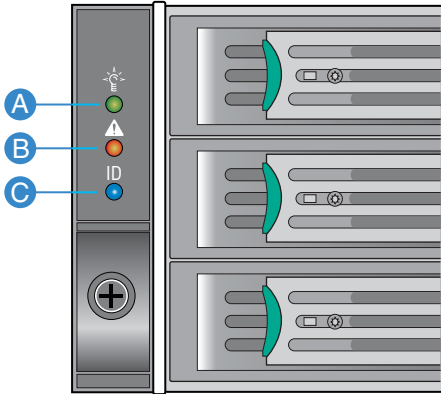
## Blanking Plates

Blanking plates must be fitted in any vacant power supply module or PCI card slots at the rear of the storage system to maintain proper airflow and ensure correct operation.

**Warning:** Operation of the storage system with ANY modules missing will disrupt the airflow and the drives will not receive sufficient cooling.

## Front Panel

The front panel provides visibility access to three LEDs.



TP01833

**Figure 10. Front Panel**

- 
- A. Power LED
  - B. Fault LED
  - C. ID LED
-

**Table 1. Front Panel Descriptions**

<b>Power LED</b>	Continuous green light indicates the system has power applied to it. No light indicates the system does not have power applied to it (other than 5-V standby power).
<b>Fault LED</b>	Continuous amber light indicates a fault is present.
<b>ID LED</b>	The blue system identification LED is used to help identify a system for servicing. This is especially useful when the system is installed within a high-density rack or cabinet that is populated with several similar systems.

**Warning:** *The Front Panel is an integral part of the chassis and is not field replaceable.*

## Spare Parts and Accessories

The following replaceable parts are available for the Intel® Storage System SSR212CC.

**Table 2. Spare Parts and Accessories**

<b>Part Number</b>	<b>Description</b>
FXSCABLES	Cable Kit (three SATA cables in bundles of four, I <sup>2</sup> C cable, 2-pin cable, RJ-45 serial cable)
FXCCHASSIS	Chassis
FXSDRVCARR	Drive carriers (including torque screwdriver and hard drive label set)
FXSIPOSER	Interposer board (connects fan tray assembly to backplane)
FXSPSCAGE	Power supply cage
FXSFANTRAY	Fan tray assembly (includes fan distribution board)
SE7520JR2ATAD2	Intel® Server Board SE7520JR2
ADRACTRIS	2U three-slot active PCI-X riser for Intel® RAID Controller SRCS28X
SRCS28X	Intel® RAID Controller SRCS28X
AXXRIBBU1	Battery backup unit for Intel® RAID Controller SRCS28X
TLPACPSU002	500-W power supply
AXXIMMPRO	Intel® Management Module Professional for Intel® Server Board SE7520JR2

# 2 Hardware Installations and Upgrades

---

This chapter provides instructions for removing, installing, and replacing storage system components in your Intel® Storage System SSR212CC.

**Caution:** *When connecting the Intel® Storage System SSR212CC to a power source, use either the power cords that shipped with the system, or match the power cord specifications listed under “Power Cord” on page 114.*

**Caution:** *It is recommended that you fit and check a suitable anti-static wrist and conductive foam pad and observe all conventional ESD precautions when handling storage system modules and components. Avoid contact with the backplane components and module connectors.*

## Before You Begin

Before working with your storage system, review the important safety information listed in Appendix D, “Safety Information”.

## Tools and Supplies Needed

- #10 TORX\* screwdriver
- Phillips\* (cross head) screwdriver (#1 bit and #2 bit)
- Needle-nosed pliers
- Anti-static wrist strap and conductive foam pad (recommended)

## System References

All references to left, right, front, top, and bottom assume the reader is facing the front of the storage system as it would be positioned for normal operation.

## Planning Your Installation

Power down your host computer and all attached peripheral devices before beginning installation.

If the storage system is used with modules or blanking plates missing for more than a few minutes, the system can overheat, causing power failure and data loss. Such use may also invalidate the warranty.

All modules and/or blanking plates must be in place for the air to flow correctly around the storage system and to complete the internal circuitry.

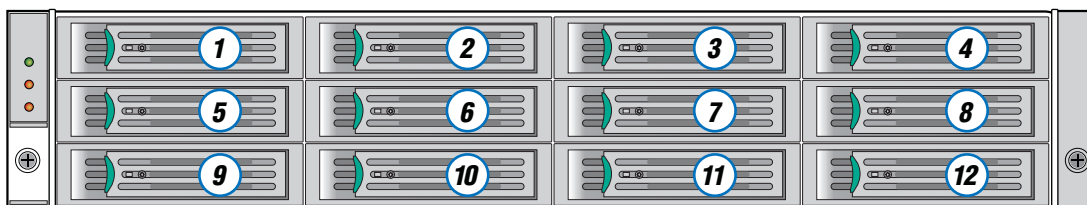
Before beginning your storage system installation, review the configuration requirements listed in [Table 3](#) for the Intel® Storage System SSR212CC.

**Table 3. Configuration Requirements**

Module	Location
Drive Bays	To ensure proper airflow, ALL drive bays must be fitted with either a drive carrier or a blank drive carrier. No bays should be left completely empty. A minimum of one drive should be installed.
Power Supply Modules	One power supply module must be installed in the power supply enclosure. Full power redundancy is available by installing a second power supply module.

## Drive Bay Numbering Convention

The drive bay numbering convention is shown in the following figure.



TP01831

**Figure 11. Drive Bay Numbering**

A bay is defined as the space required to house a single 1.0-in high 3.5-in disk drive in its carrier module, e.g., a 1 x 4 bay bank would take the space of one drive width by four drive bays across (in the rack mount configuration).

The Intel® Storage System SSR212CC subsystem is housed in a 4 x 3 enclosure, i.e., four drive bays wide by three bays high. The top bays are numbered 1 to 4 from left to right, as viewed from the front. Drive carrier module locations are identified from a matrix of the top and side numbers. Additional drives must be populated in order from left to right, top to bottom, beginning with Drive Bay 1 and ending with Drive Bay 12.

**Warning:** *Operation of the enclosure with ANY modules missing will disrupt the airflow and the drives will not receive sufficient cooling. It is ESSENTIAL that all apertures are filled before operating the unit. Dummy drive carrier modules are available for fitting in unused drive bays.*

## Installing the Enclosure in a Rack System

**Warning:** *The Intel® Storage System SSR212CC enclosure with all its component parts installed is too heavy for a single person to easily install into a rack cabinet. The following procedures describe the installation of the enclosure and highlight any critical pre-requisite requirements and good handling practices which we encourage you to follow so as to ensure that a successful installation is achieved in the easiest manner.*

**Caution:** *Ensure that you have fitted and checked a suitable anti-static wrist or ankle strap and observe all conventional ESD precautions when handling modules and components. Avoid contact with the backplane, server board and PCI card components and module connectors, etc.*

The enclosure is designed for installation into an industry standard 19-in cabinet capable of holding the unit.

- Minimum depth, 500 mm from front flange to rear metalwork (excludes rear cabling)
- Weight: up to 30 kg, dependent upon configuration, per enclosure
- A minimum gap of 25-mm (1-in) clearance between the rack cover and front of drawer, and 50-mm (2-in) rear clearance between rear of drawer and rear of rack is recommended in order to maintain the correct airflow around the enclosure.
- The rack should present a maximum back pressure of 5 pascals (0.5-mm water gauge).

## Rack System Precautions

The following safety requirements must be considered when the storage system is mounted in a rack:

- The rack construction must be capable of supporting the total weight of the installed storage system and the design should incorporate stabilizing features suitable to prevent the rack from tipping or being pushed over during installation or in normal use.
- When loading a rack with units, fill the rack from the bottom up and empty from the top down.

**Warning:** *It is recommended that you do not slide more than one unit out of the rack at a time, to avoid danger of the rack toppling over. Under no circumstances should more than one unit be drawn out of any cabinet at any one time.*

- The system must be operated with low pressure rear exhaust installation (back pressure created by rack doors and obstacles not to exceed 5 pascals [0.5-mm water gauge]).
- The rack design should take into consideration the maximum operating ambient temperature for the storage system, which is 35°C.
- The rack should have a safe electrical distribution system. It must provide over-current protection for the storage system and must not be overloaded by the total

number of units installed in the rack. Consideration of the units' nameplate rating should be used when addressing these concerns.

- The electrical distribution system must provide a reliable earth for each unit and the rack.
- Each storage system has an earth leakage current of 0.75 mA. The design of the electrical distribution system must take into consideration the total earth leakage current from all the power supplies in all the units. The rack will require labelling with "HIGH LEAKAGE CURRENT. Earth connection essential before connecting supply."
- The rack when configured with the units must meet the safety requirements of UL 60950-1 and IEC 6095-10.

## Rack Mount Rail Kit

A set of mounting rails is available for use in 19-in rack cabinets. These rails have been designed and tested to handle the maximum enclosure weight and to ensure that multiple enclosures may be installed without loss of space within the rack. Use of other mounting hardware may cause some loss of rack space.

## Assembling the Rail Kit

Please refer to the *Rail Kit Install Guide: Intel® Storage System SSR212MA/Intel® Storage System SSR212CC* supplied with the rack mounting rail kit for assembly details.

## Removing or Installing the Enclosure Cover

**Warning:** *The enclosure cover must only be removed by a service personnel. Potential hazards include:*

- *Energy hazard*
- *Rotating fans*
- *Hot surfaces*
- *Access to power supply unit openings*

*Upon replacement, the cover MUST be secured by tightening the retaining screw with a screwdriver.*

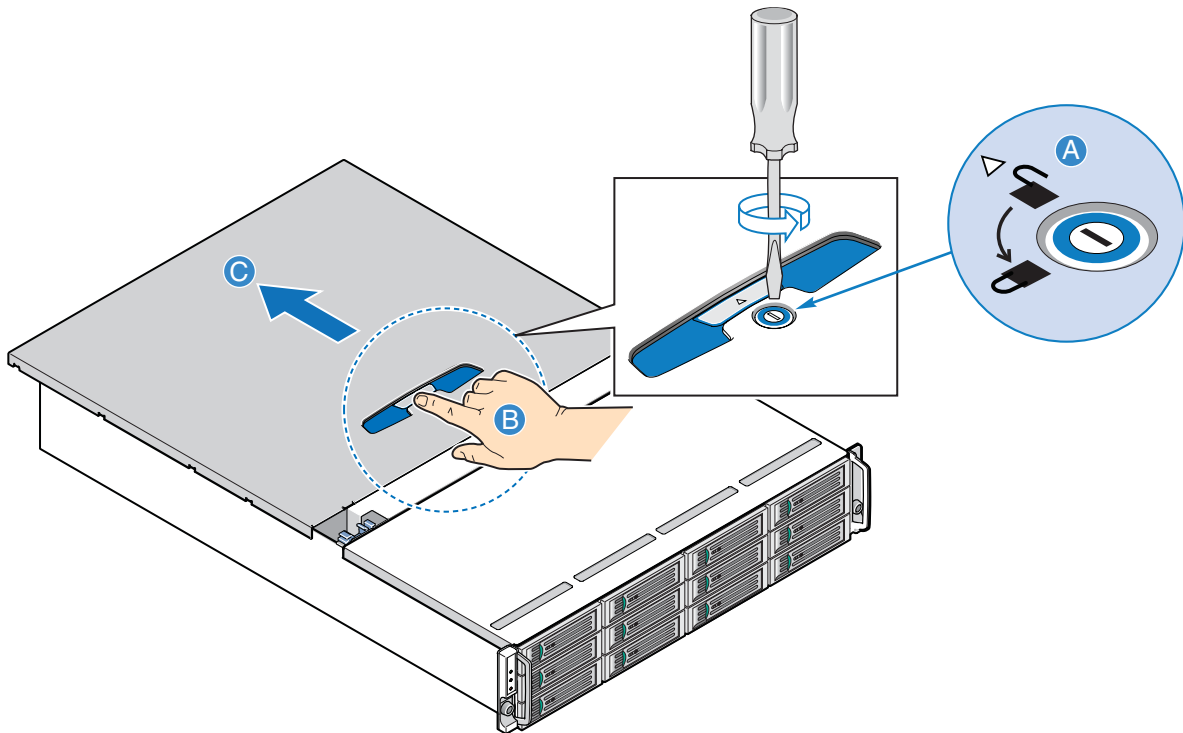
## Removing the Enclosure Cover

**Important:** *The cover should only be removed by service personnel as it provides access to a service area.*

1. Observe all safety and ESD precautions listed in [Appendix D, "Safety Information"](#).



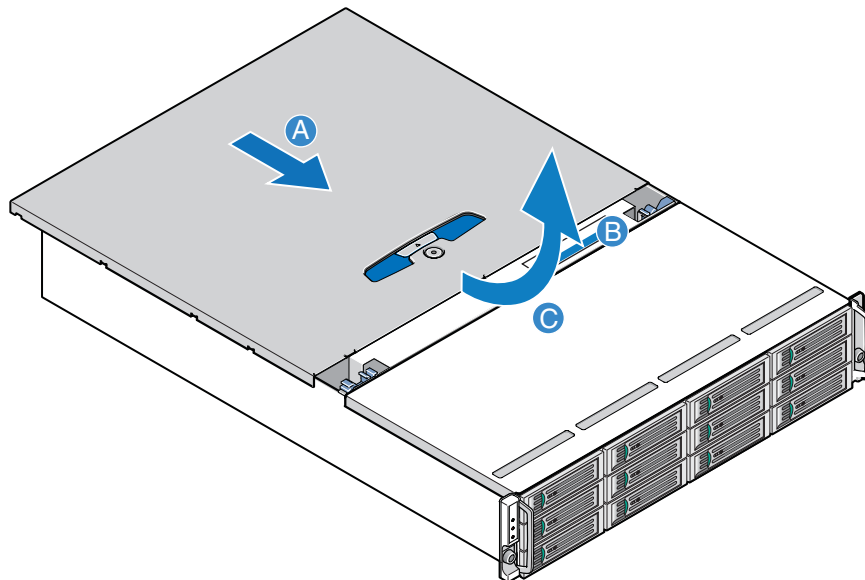
2. Release the lock by turning the screw a quarter turn until the open lock symbol aligns with the notch on the cover (see letter “A” in the following figure). Press in on the palm latch (see letter “B”) and slide the enclosure cover back (see letter “C”) until it stops (about 2 inches).



TP01826

**Figure 12. Unlatching Enclosure Cover**

3. Next, slide the enclosure cover forward (see letter “A” in the following figure) up to the blue lid removal zone displayed on the top of the cooling module (see letter “B”). Lift the enclosure cover (see letter “C”) to completely remove it from the chassis.



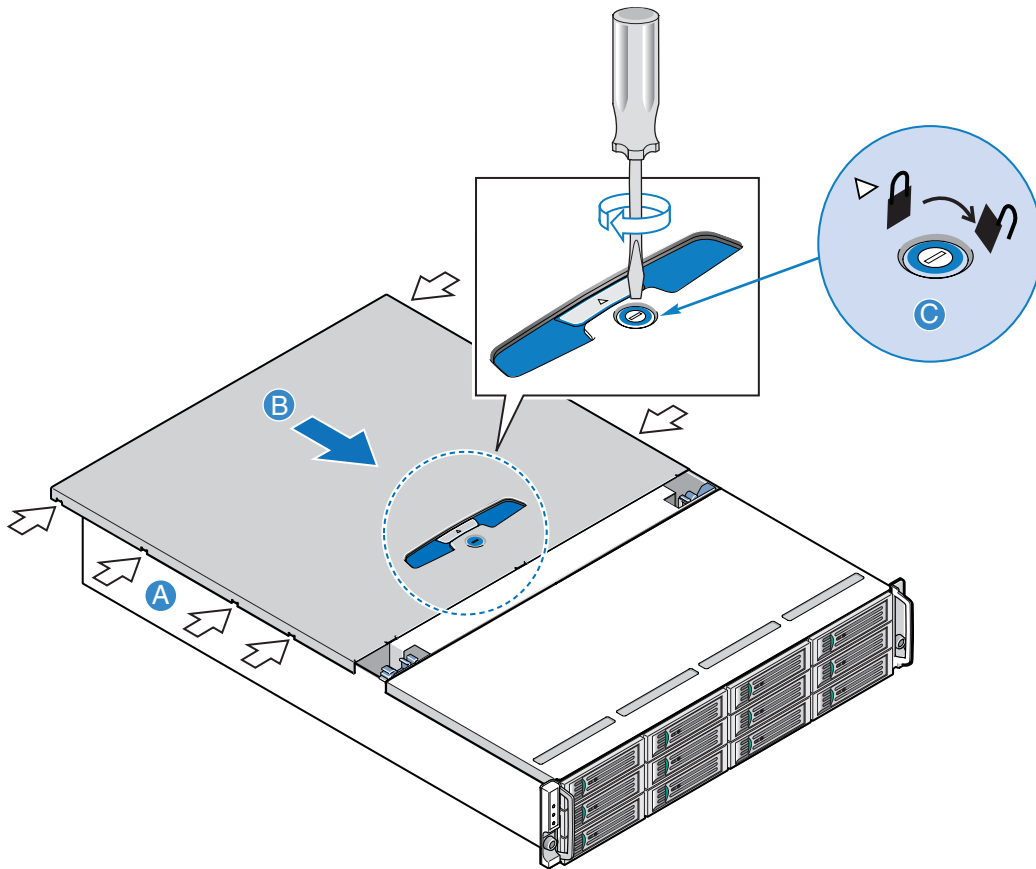
TP01827

**Figure 13. Removing Enclosure Cover**

## Installing the Enclosure Cover

**Important:** The enclosure cover *MUST* be secured to the chassis by tightening the retaining screw at the rear of the enclosure cover.

1. Observe all safety and ESD precautions listed in [Appendix D, “Safety Information”](#).
2. Align the enclosure cover over the corresponding notches in the chassis (see letter “A” in the following figure). Slide the enclosure cover toward the front of the chassis (see letter “B”). With a screwdriver, secure the enclosure cover to the chassis by tightening the lock a quarter turn until the close lock symbol aligns with the notch on the cover (see letter “C”).



TP01847

**Figure 14. Installing Enclosure Cover**

## Removing or Installing a Power Supply Module

A power supply module can be replaced if it fails. If your storage system uses a redundant power supply system, you do not need to power down the system to replace the failed power supply module as long as the remaining power supply module is plugged into an AC power source and is functioning.

**Important:** *If only one power supply module is used in the storage system, a blanking plate must be fitted to cover the unused righthand slot and lower AC input socket. Operation of the storage system with ANY modules missing will disrupt airflow and the drives will not receive sufficient cooling. It is ESSENTIAL that all apertures are filled before operating the system.*

## Removing a Power Supply Module

**Note:** The storage system does not need to be powered down if replacing a failed power supply module in a hot swap (redundant) power supply system. The storage system must be powered down if replacing a failed power supply module in a non-redundant power supply system.

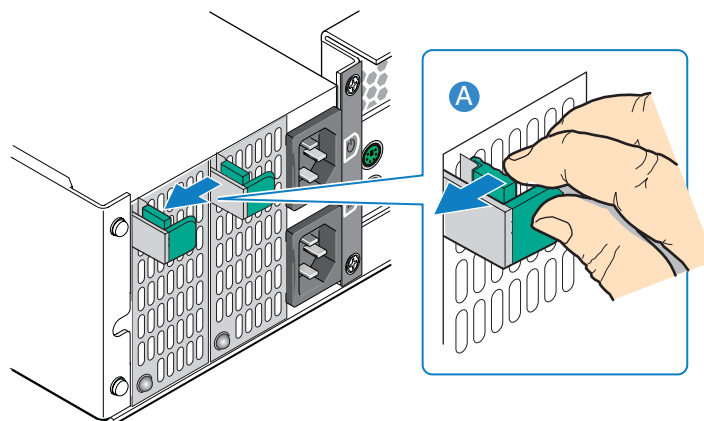
**Caution:** Before performing any maintenance on the system, back up the data. Follow the instructions in the operating system manual for shutting down the system.

**Warning:** Do not remove a faulty redundant power supply module unless you have a replacement module of the correct type ready for insertion.

**Warning:** A failed redundant power supply module should be replaced in less than 30 seconds to ensure proper airflow.

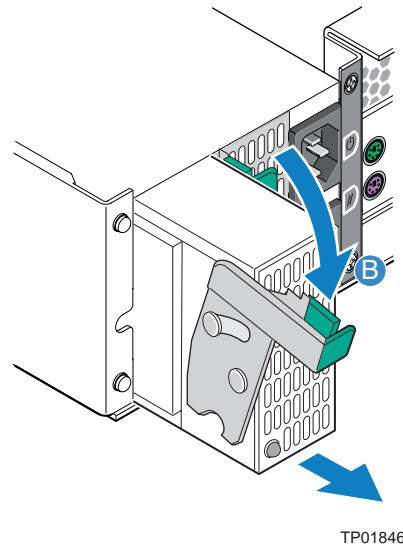
**Warning:** Do not remove covers from a power supply module. Danger of electric shock exists inside. Return the power supply module to your supplier for repair.

1. Observe all safety and ESD precautions listed in [Appendix D, “Safety Information”](#).
2. For non-redundant power supply systems only, power down the storage system. See the *Intel® Storage System Software User’s Manual* for instructions on powering down the system.
3. Remove the AC power cable from the failed power supply module. The top AC connector is for the left power supply. The bottom connector is for the right power supply.
4. Press in the inside green latch at the rear of the power supply module to release the latching mechanism (see letter “A” in the following figure). While pressing in on the inside green latch, pull down on the outside green lever (see letter “B” in Figure 16) to eject the power supply module from the chassis. Remove the power supply module from the chassis.



TP01845

**Figure 15. Unlatching a Power Supply Module**



**Figure 16. Removing a Power Supply Module**

## Installing a Power Supply Module

**Caution:** Before performing any maintenance on the system, back up the data. Follow the instructions in the operating system manual for shutting down the system.

**Warning:** This procedure should be performed by Service Personnel Only.

**Warning:** Do not remove the covers from a power supply module. Danger of electric shock exists inside. Return the power supply module to your supplier for repair.

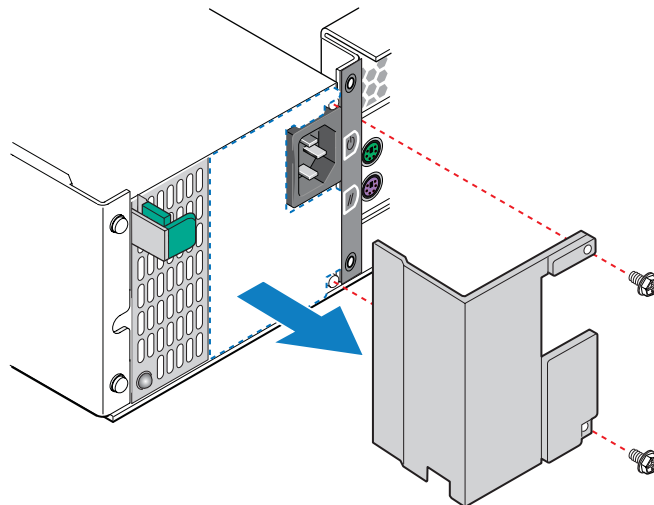
**Caution:** Handle the power supply module carefully and avoid damaging the connector pins. Do not install the power supply module if any pins appear to be bent.

**Important:** If only one power supply module is to be installed in the storage system, it must be installed in the lefthand slot with the top AC input socket used for connection to the power source. A blanking plate must be fitted to cover the empty righthand slot and the unused (lower) AC input socket. Operation of the storage system with ANY modules and/or blanking plates missing will disrupt the airflow and the drives will not receive sufficient cooling. It is **ESSENTIAL** that all apertures are filled before operating the unit.

To install a replacement power supply module or to add a redundant power supply module, use the following instructions:

1. Observe all safety and ESD precautions listed in [Appendix D, “Safety Information”](#).
2. (For replacing a power supply module only) Remove the failed power supply module. For instructions, see [“Removing a Power Supply Module”](#) on page 18.

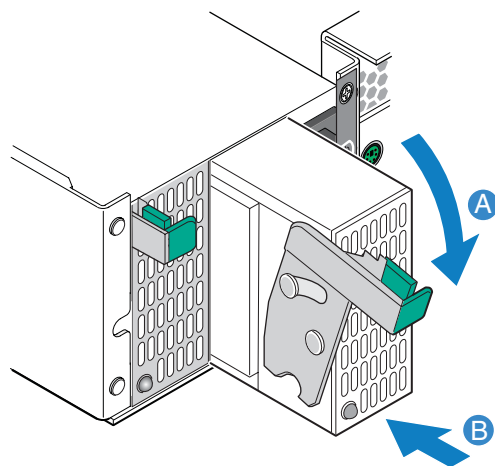
3. (For installing a redundant power supply module only) Remove the two screws securing the blanking plate to the chassis. Remove the blanking plate. Re-install the two screws.



TP01848

**Figure 17. Removing Blanking Plate**

4. Push the green lever down (see letter “A” in the following figure) and slide the new power supply module into the power supply cage (see letter “B”) until it clicks into place.



TP01849

**Figure 18. Inserting Power Supply Module**

5. Plug in the AC power cable to the new power supply module.
6. On non-redundant power supply systems, power up the storage system.

## Connecting the Power Cord(s)

1. Observe all safety and ESD precautions listed in [Appendix D, “Safety Information”](#).
2. Attach the power cord(s) to all installed power supply modules (see letter “A” in the following figure).

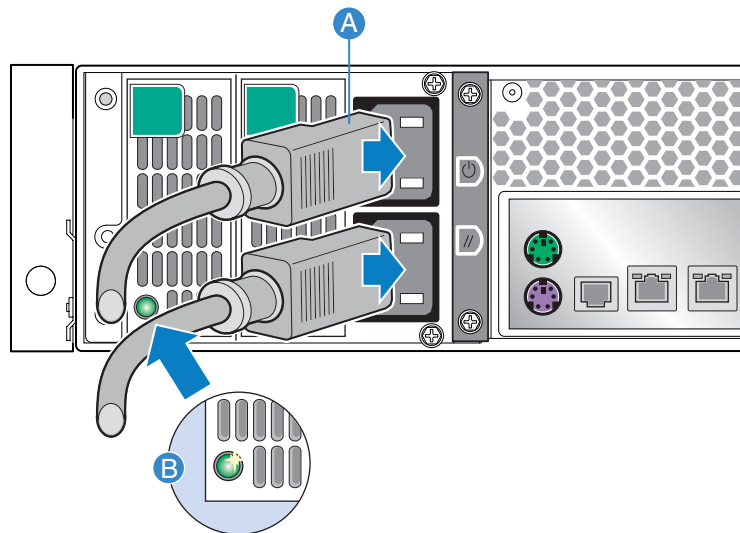
**Note:** *If power was previously interrupted, the storage system may boot up when you plug in the AC power cord(s). If this happens, it is because the “Resume on AC Power Loss” setting in the BIOS has been set to “Power On.”*

**Warning:**

**Important:** *To ensure redundancy in redundant power supply systems, the two power cords must be connected to separate and independent supplies.*

3. The Power On LED on each power supply module (see letter “B”) indicates whether AC mains power is present.

**Caution:** *The power connections must always be disconnected prior to removal of the power supply unit from the enclosure.*



TP01850

**Figure 19. Connecting Power Cords**

## Grounding Checks

This product must only be connected to a power source that has a safety electrical earth connection.

**Warning:** *If more than one product is fitted in a rack, the earth connection to the rack is even more important, because the rack will then have a high “EARTH LEAKAGE CURRENT” (“TOUCH CURRENT”).*

The earth connection to the rack must be checked before switching on, by an electrical engineer who is qualified to the appropriate local and National standards to perform the check.

## Removing or Installing the PCI Riser Assembly

Always operate your storage system with the PCI riser assembly in place. The PCI riser assembly is required for proper airflow within the chassis. You will need to remove the PCI riser assembly from the chassis to replace the PCI riser connectors, or to add or remove a PCI add-in card.

**Warning:** *This module is not “hot-pluggable”. Prior to removing the riser card module from the enclosure, disconnect the power from the power supply by either turning off the main switch (if present) or by physically removing the power source.*

## Blanking Plates

A blanking plate must be fitted into any vacant PCI card slots.

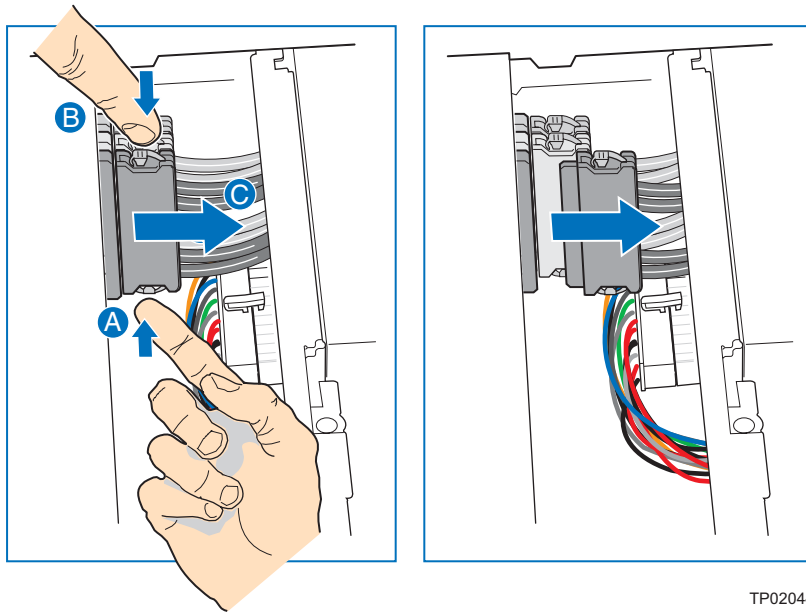
## Removing the PCI Riser Assembly

**Caution:** *Before performing any maintenance on the system, back up the data. Follow the instructions in the Intel® Storage System Software User Manual for shutting down the system.*

1. Observe all safety and ESD precautions listed in [Appendix D, “Safety Information”](#).
2. Turn off all peripheral devices connected to the storage system. Turn off the storage system.
3. Disconnect the AC power cord(s).
4. Remove the enclosure cover. For instructions, see [“Removing the Enclosure Cover” on page 14](#).
5. Remove the cooling module. For instructions, see [“Removing the Cooling Module” on page 51](#).
6. Remove the processor air duct. For instructions, see [“Removing the Processor Air Duct” on page 72](#).



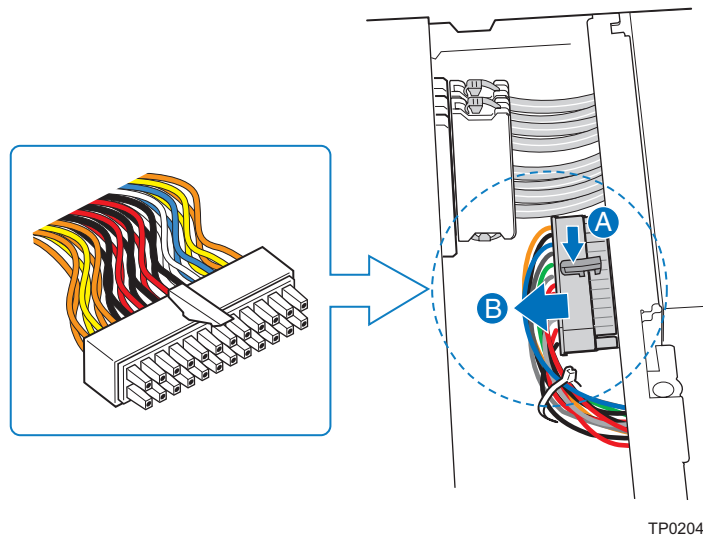
7. Disconnect the first SATA cable from backplane by pressing in on the top and bottom latches of the connector (see letters “A” and “B” in the following figure).



TP02044

**Figure 20. Disconnecting First SATA Cable**

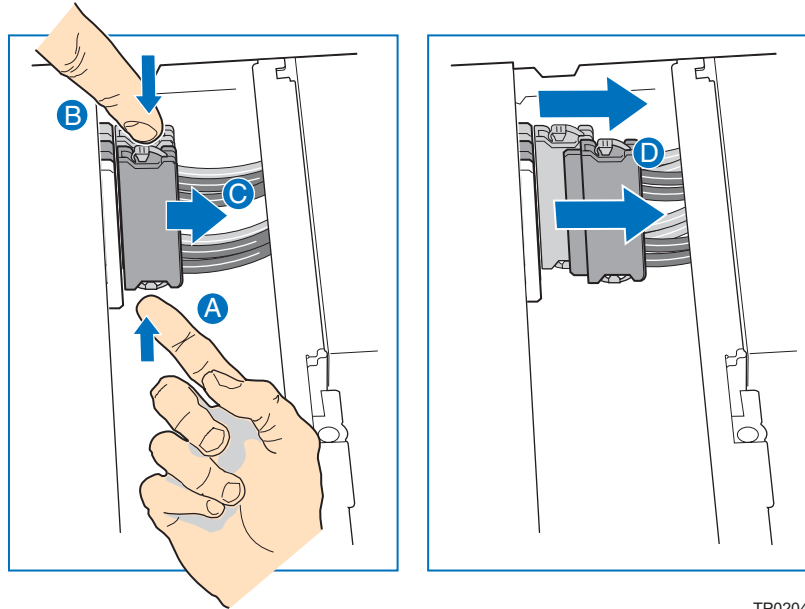
8. Lift up on latch (see letter “A” in the following figure) and disconnect the main power (P1) cable from the server board (see letter “B”).



TP02045

**Figure 21. Disconnecting Main Power (P1) Cable from Server Board**

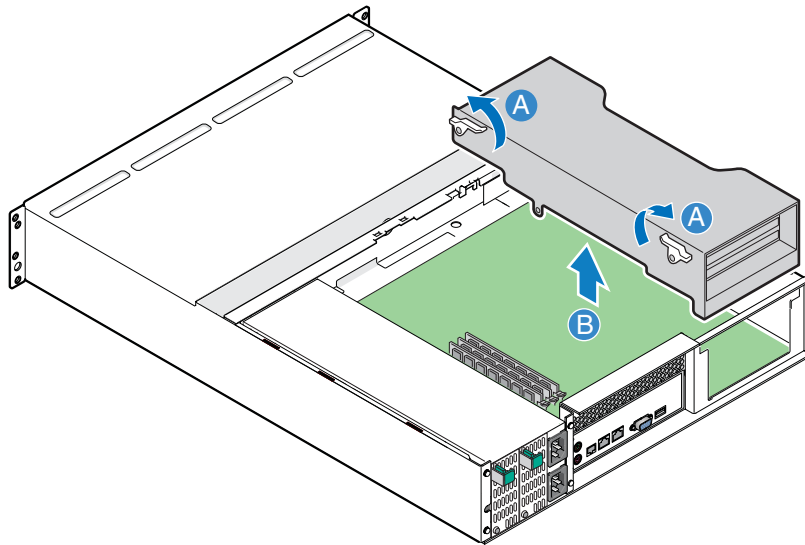
9. Disconnect the remaining two SATA cables connected to the backplane by pressing in on the top and bottom latches of the connector (see letters “A” and “B” in the following figure).



TP02046

**Figure 22. Disconnecting Remaining Two SATA Cables**

10. Remove the tie wrap from around the SATA cables.
11. Unlatch the two levers (see letter “A” in the following figure) on the PCI riser assembly and lift the assembly out of the chassis (see letter “B”). Guide the SATA cables so that they clear the opening in the cross bar. Lay the PCI riser assembly on an anti-static surface.



TP02043

**Figure 23. Removing PCI Riser Assembly from Chassis**

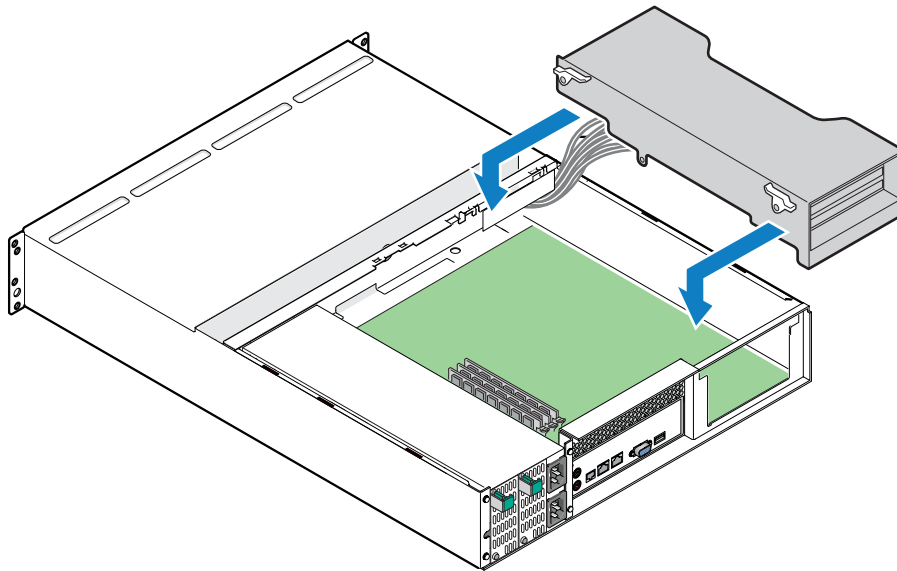
12. If you need to add or replace an Intel® RAID Controller SRCS28X, see [“Removing and Installing an Intel® RAID Controller”](#) on page 30.
13. If you removed the PCI riser assembly as part of another procedure, continue with that procedure.

## Installing the PCI Riser Assembly

**Caution:** Before performing any maintenance on the system, back up the data. Follow the instructions in the operating system manual for shutting down the system.

**Caution:** Do not operate the storage system without the presence of a PCI riser assembly.

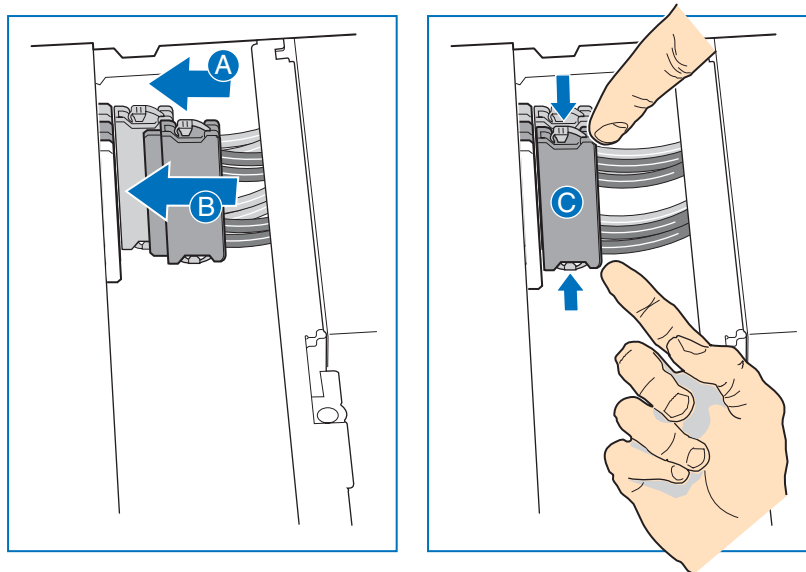
1. Observe all safety and ESD precautions listed in [Appendix D, “Safety Information”](#).
2. Install any necessary add-in cards into the PCI riser assembly. For instructions on installing the Intel® RAID Controller SRCS28X, see [“Installing an Intel® RAID Controller”](#) on page 33.
3. Ensure the SATA cables connected to the RAID controller cards are properly connected. Match the hooks on the back of the PCI riser assembly with the notches on the cross bar and rear of the chassis. While routing the SATA cables through the opening in the cross bar, guide the PCI riser assembly home by firmly gripping and sliding the assembly downwards until the riser card mates with the connector on the server board. The latches should lock into position once the PCI riser assembly is seated properly.



TP02055

**Figure 24. Installing PCI Riser Assembly into Chassis**

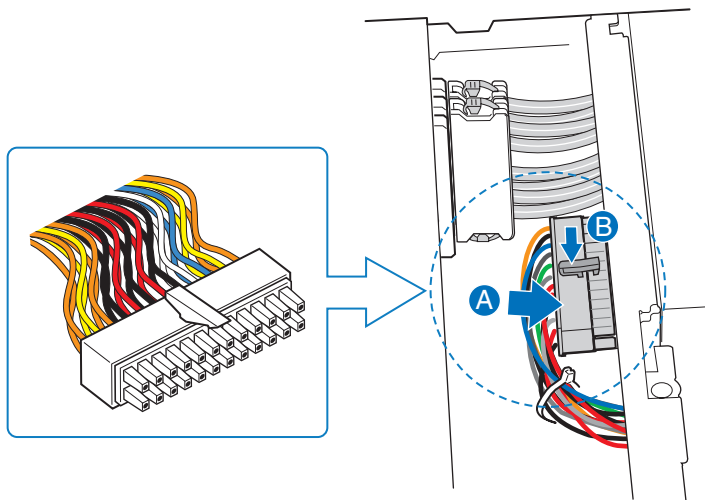
4. Connect the two SATA cables nearest the side of the chassis (see letters “A” and “B” in the following figure) to their connectors on the backplane (see letter “C”).



TP02052

**Figure 25. Connecting First Two SATA Cables**

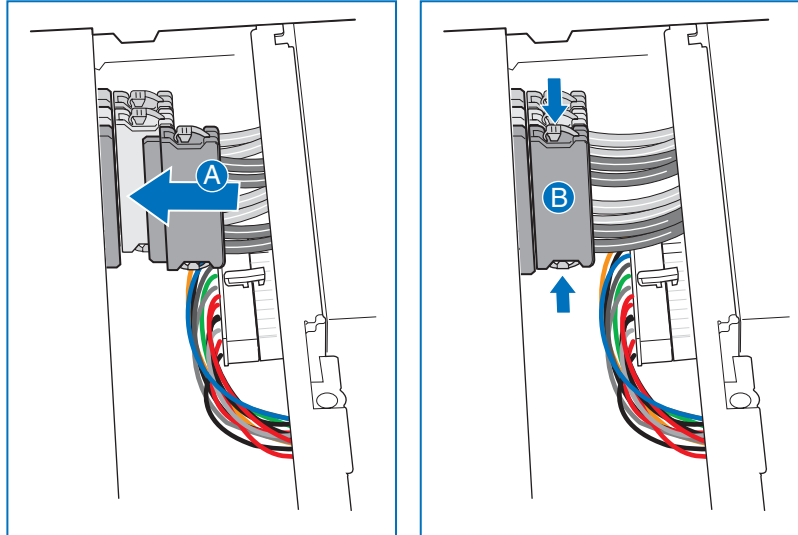
5. Connect the main P1 power cable to its connector on the server board (see letter “A” in the following figure). When properly seated, the latch on the top of the connector (see letter “B”) should lock the connector into position.



TP02053

**Figure 26. Connecting Main Power Cable**

6. Connect the remaining SATA cable (see letter “A” in the following figure) to its connector on the backplane (see letter “B”). Check the other SATA cables connected to the backplane to ensure that they are properly connected and have not come loose.



TP02054

**Figure 27. Connecting Third SATA Cable to Server Board**

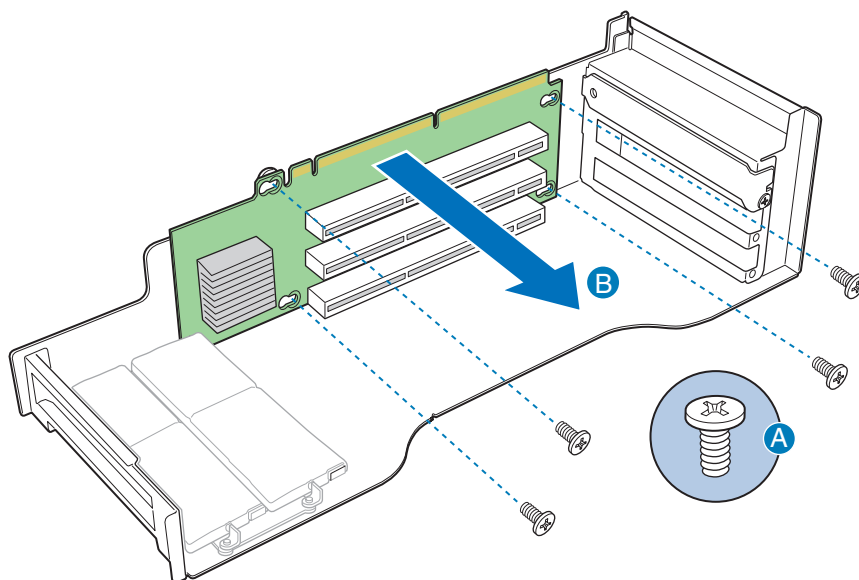
7. Secure a tie wrap around the SATA cables.
8. If the PCI riser assembly is being installed as part of another procedure, continue with that procedure.
9. Re-install the cooling module. For instructions, see [“Installing the Cooling Module” on page 54](#).
10. Re-install the processor air duct. For instructions, see [“Installing the Processor Air Duct” on page 73](#).
11. Install the enclosure cover. For instructions, see [“Installing the Enclosure Cover” on page 16](#).
12. Re-connect all peripheral devices and the AC power cable. Power up the storage system.

## Replacing a PCI Riser Connector Card

A PCI riser connector card can be replaced if it fails or if a different option is required.

**Caution:** Before performing any maintenance on the system, back up the data. Follow the instructions in the operating system manual for shutting down the system.

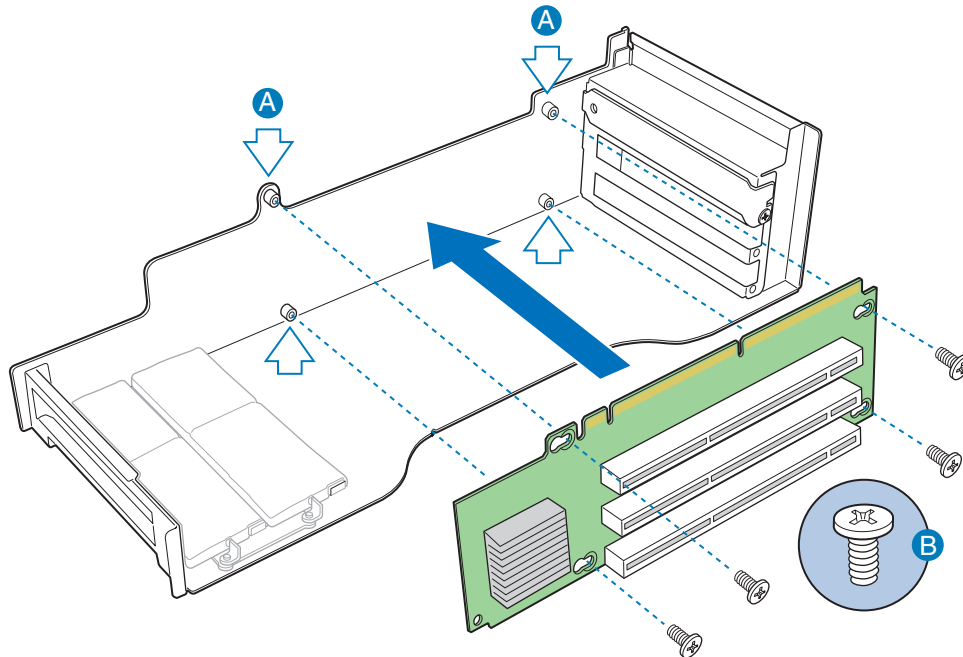
1. Observe all safety and ESD precautions listed in [Appendix D, “Safety Information”](#).
2. Turn off all peripheral devices connected to the storage system. Turn off the storage system.
3. Disconnect the AC power cord(s).
4. Remove the enclosure cover. For instructions, see [“Removing the Enclosure Cover” on page 14](#).
5. Remove the PCI riser assembly. For instructions, see [“Removing the PCI Riser Assembly” on page 22](#).
6. Remove any installed Intel® RAID Controller SCRS28X cards. For instructions, see [“Removing an Intel® RAID Controller” on page 30](#).
7. Remove the four screws securing the old PCI riser connector card to the PCI riser assembly (see letter “A” in the following figure). Detach the old PCI riser connector card from the PCI riser assembly (see letter “B”).



TP02063

**Figure 28. Removing PCI Riser Connector Card from PCI Riser Assembly**

8. Line up the stand-offs on the PCI riser assembly with the screw holes on the new PCI riser connector card (see letter “A” in the following figure). Secure the new PCI riser connector card to the PCI riser assembly with four screws (see letter “B”).



TP02064

**Figure 29. Securing PCI Riser Connector Card to PCI Riser Assembly**

9. Install any Intel® RAID Controller SRCS28X cards. For instructions, see [“Installing an Intel® RAID Controller”](#) on page 33.
10. Re-install the PCI riser assembly into the chassis. For instructions, see [“Installing the PCI Riser Assembly”](#) on page 25.
11. Install the enclosure cover. For instructions, see [“Installing the Enclosure Cover”](#) on page 16.
12. Re-connect all peripheral devices and the AC power cable. Power up the storage system.

## Removing and Installing an Intel® RAID Controller

Up to two Intel® RAID Controller cards can be installed in the upper two slots of the PCI riser assembly. The third riser slot is currently not used, but may be available in future upgrades.

### Removing an Intel® RAID Controller

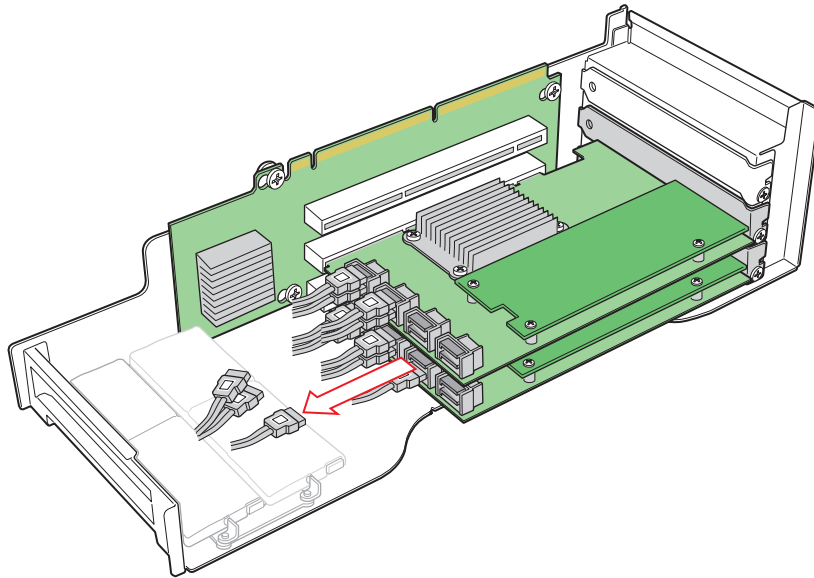
**Caution:** Before performing any maintenance on the system, back up the data. Follow the instructions in the operating system manual for shutting down the system.

**Caution:** Refer to the support site at <http://www.intel.com/support/motherboards/server/ssr212ma> for the appropriate firmware version to use.

1. Observe all safety and ESD precautions listed in [Appendix D, “Safety Information”](#).
2. Turn off all peripheral devices connected to the storage system. Turn off the storage system.
3. Disconnect the AC power cord(s).
4. Remove the enclosure cover. For instructions, see [“Removing the Enclosure Cover” on page 14](#).
5. Remove the cooling module. For instructions, see [“Removing the Cooling Module” on page 51](#).
6. Remove the PCI riser assembly. For instructions, see [“Removing the PCI Riser Assembly” on page 22](#).



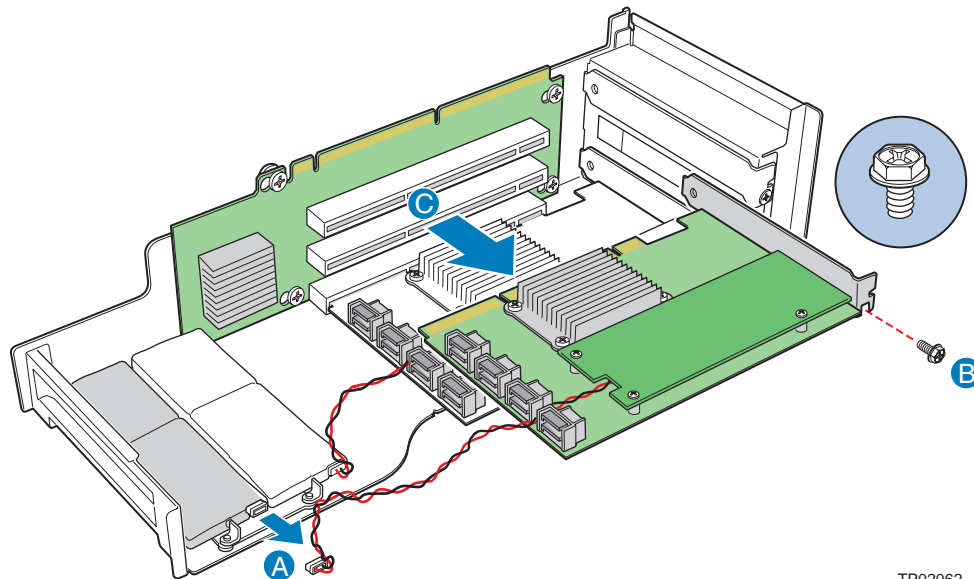
7. Disconnect the SATA cables connected to the Intel® RAID Controller being replaced.



TP02065

**Figure 30. Disconnecting SATA Cables**

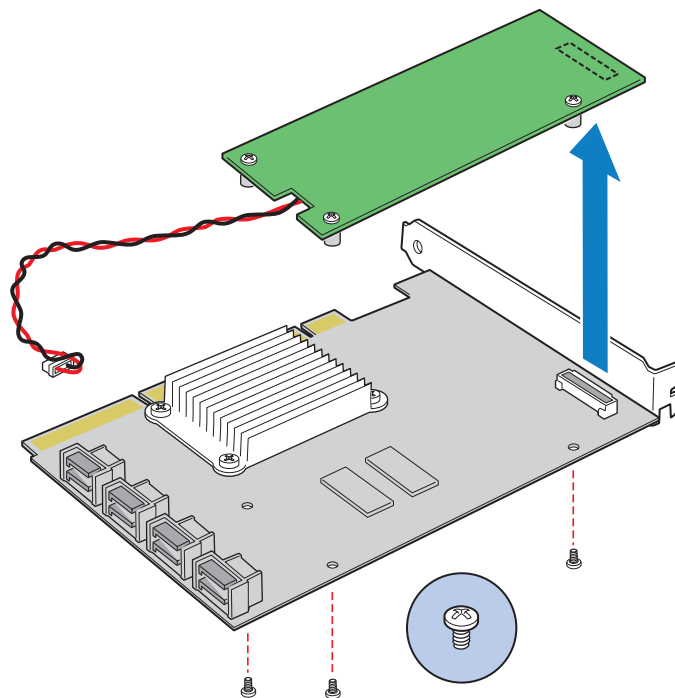
8. Disconnect the extended battery cable from the battery (see letter “A” in the following figure). Remove the screw securing the Intel® RAID Controller to the PCI riser assembly (see letter “B”). Detach the Intel® RAID Controller from its connector on the PCI riser assembly (see letter “C”).



TP02062

**Figure 31. Removing Intel® RAID Controller from PCI Riser Assembly**

9. Remove the three screws securing the battery backup unit to the Intel® RAID Controller. Remove the battery backup unit.



TP02338

**Figure 32. Removing Battery Backup Unit**

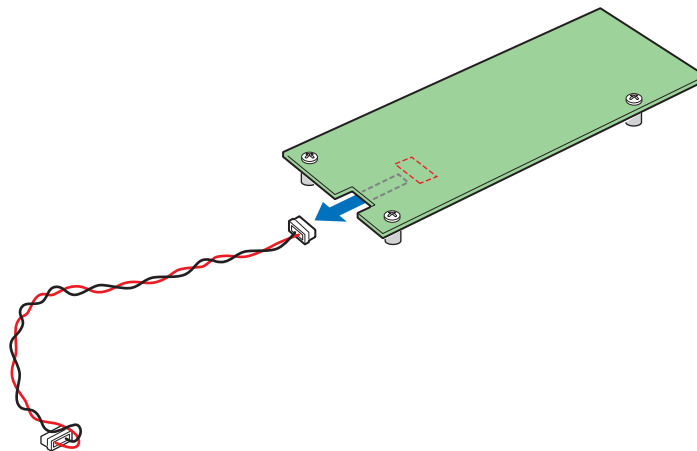
10. If removing the Intel® RAID Controller as part of another procedure, continue with that procedure.
11. If replacing with a new Intel® RAID Controller, see [“Installing an Intel® RAID Controller” on page 33](#) for instructions.
12. Re-install the PCI riser assembly into the chassis. For instructions, see [“Installing the PCI Riser Assembly” on page 25](#).
13. Install the enclosure cover. For instructions, see [“Installing the Enclosure Cover” on page 16](#).
14. Re-connect all peripheral devices and the AC power cable.

## Installing an Intel® RAID Controller

**Caution:** Before performing any maintenance on the system, back up the data. Follow the instructions in the operating system manual for shutting down the system.

**Caution:** Refer to the support site at <http://www.intel.com/support/motherboards/server/ssr212cc> for the appropriate firmware version to use.

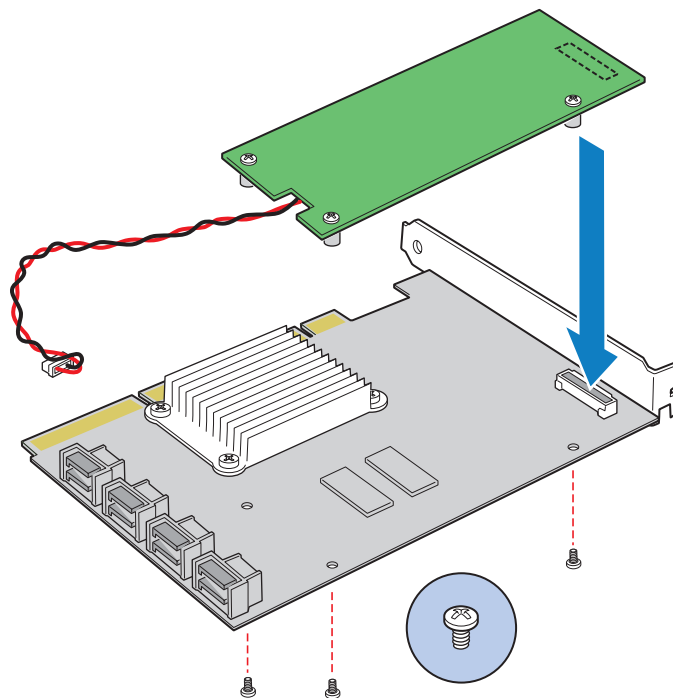
1. Observe all safety and ESD precautions listed in [Appendix D, “Safety Information”](#).
2. Turn off all peripheral devices connected to the storage system. Turn off the storage system.
3. Disconnect the AC power cord(s).
4. Remove the enclosure cover. For instructions, see [“Removing the Enclosure Cover” on page 14](#).
5. Remove the PCI riser assembly. For instructions, see [“Removing the PCI Riser Assembly” on page 22](#).
6. Unpack the Intel® RAID Controller. Remove the Intel® RAID Controller from the anti-static bag and inspect for damage. Contact Intel or your Intel support representative if the Intel® RAID Controller appears damaged.
7. Configure the jumper settings on the Intel® RAID Controller using the jumper definitions and locations in the documentation that shipped with the card.
8. Connect the extended battery cable to the battery backup unit.



TP02339

**Figure 33. Connecting Extended Battery Cable to Battery Backup Unit**

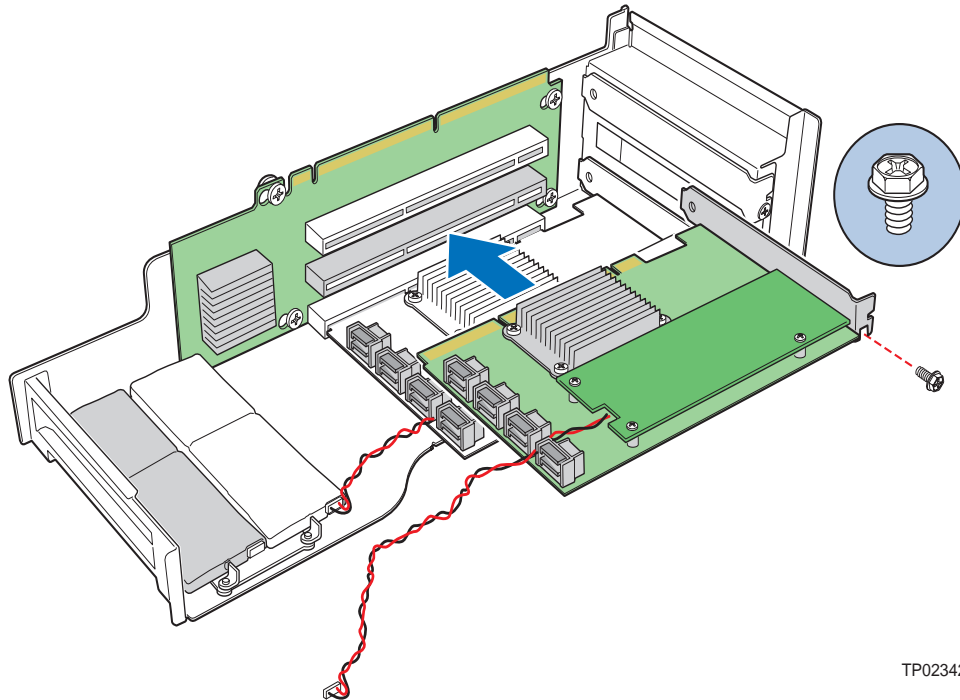
9. Align and seat the battery backup unit in its connector on the Intel<sup>®</sup> RAID Controller. Secure the battery backup unit to the Intel<sup>®</sup> RAID Controller with three screws.



TP02341

**Figure 34. Attaching Battery Backup Unit to Intel<sup>®</sup> RAID Controller**

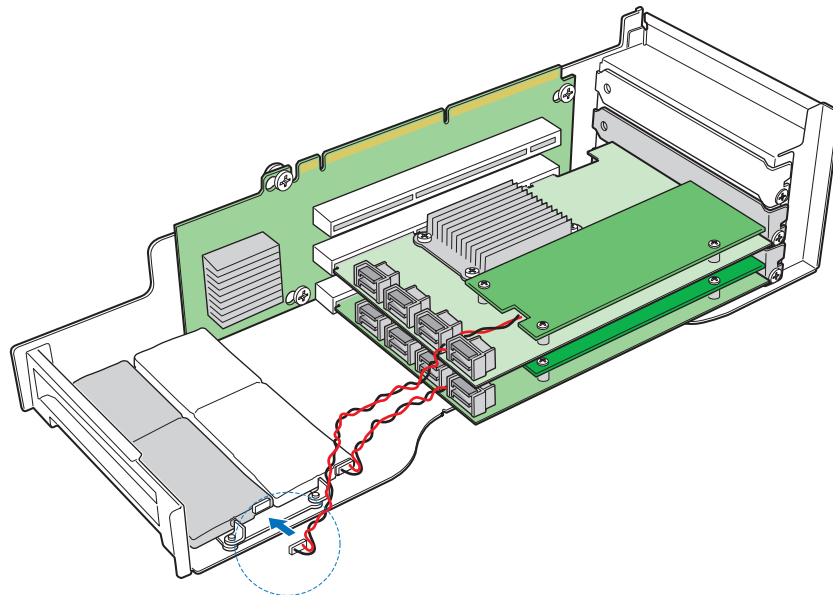
10. Align the Intel<sup>®</sup> RAID Controller with the PCI-X slot on the PCI riser connector. Press down gently but firmly to properly seat the Intel<sup>®</sup> RAID Controller in the slot.



TP02342

**Figure 35. Installing Intel<sup>®</sup> RAID Controller**

11. Attach the extended battery cable to the battery of the card being replaced.



TP02343

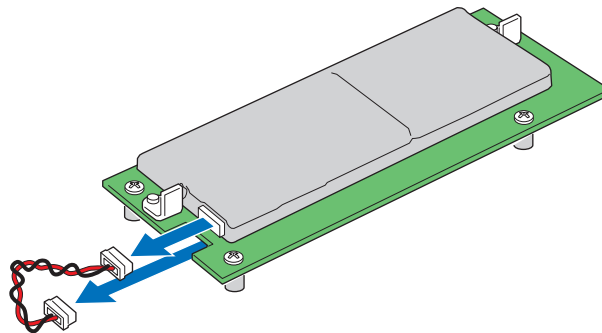
**Figure 36. Attaching Extended Battery Cable to Battery**



## Replacing the Battery for an Intel® RAID Controller

**Caution:** Before performing any maintenance on the storage system, back up the data. See the operating system manual for instructions on shutting power the system.

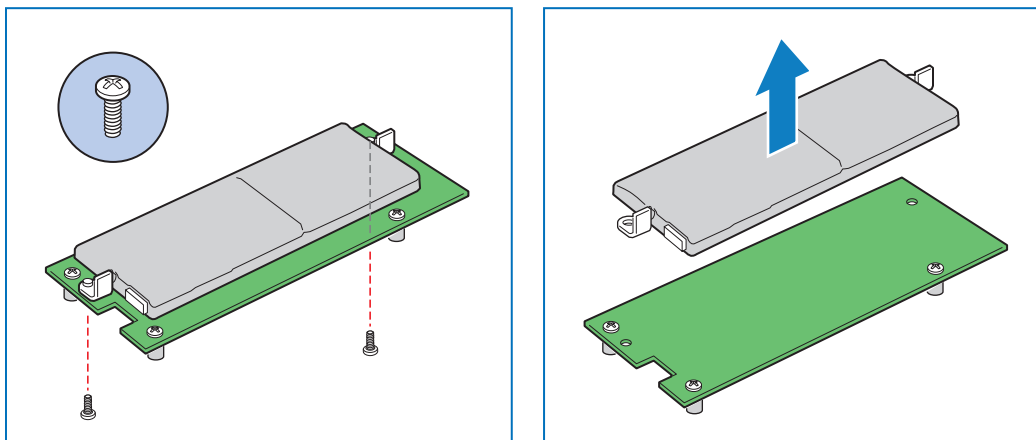
1. Observe all safety and ESD precautions listed in [Appendix D, “Safety Information”](#).
2. Remove the new battery backup unit from its packaging.
3. Disconnect both ends of the battery cable and remove from battery backup unit. (You will not be using this cable for this procedure).



TP02335

**Figure 38. Disconnecting Battery Cable from New Battery Backup Unit**

4. Remove the two screws securing the battery to the new battery backup unit.

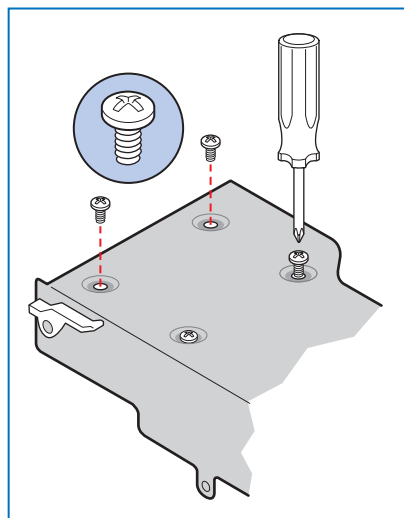


TP02333

**Figure 39. Detaching Battery from New Battery Backup Unit**

5. Turn off all peripheral devices connected to the storage system. Turn off the storage system.
6. Disconnect the AC power cord(s).
7. Remove the enclosure cover. For instructions, see [“Removing the Enclosure Cover” on page 14](#).

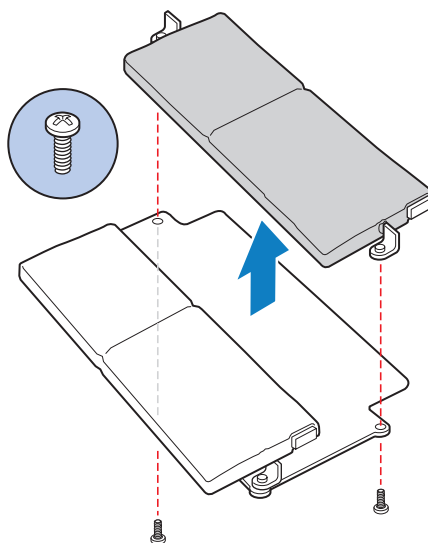
8. Remove the PCI riser assembly. For instructions, see [“Removing the PCI Riser Assembly”](#) on page 22.
9. With the top side of the PCI riser assembly facing you, use a #1 Phillips screwdriver to remove the four screws securing the battery holder to the PCI riser assembly.



TP02331

**Figure 40. Removing Battery Holder from PCI Riser Assembly**

10. Remove the two screws securing the old battery to the battery holder.

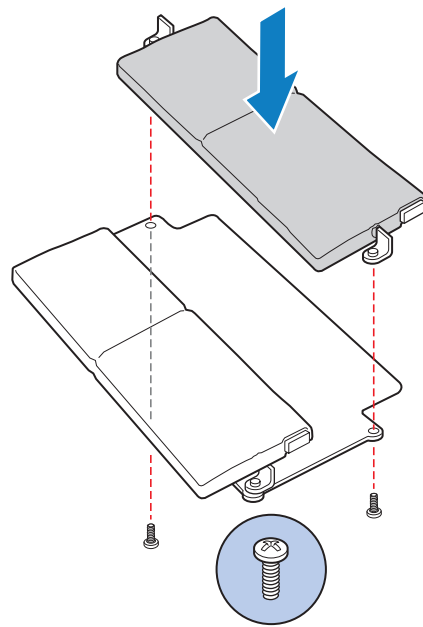


TP02332

**Figure 41. Removing Old Battery from Battery Holder**



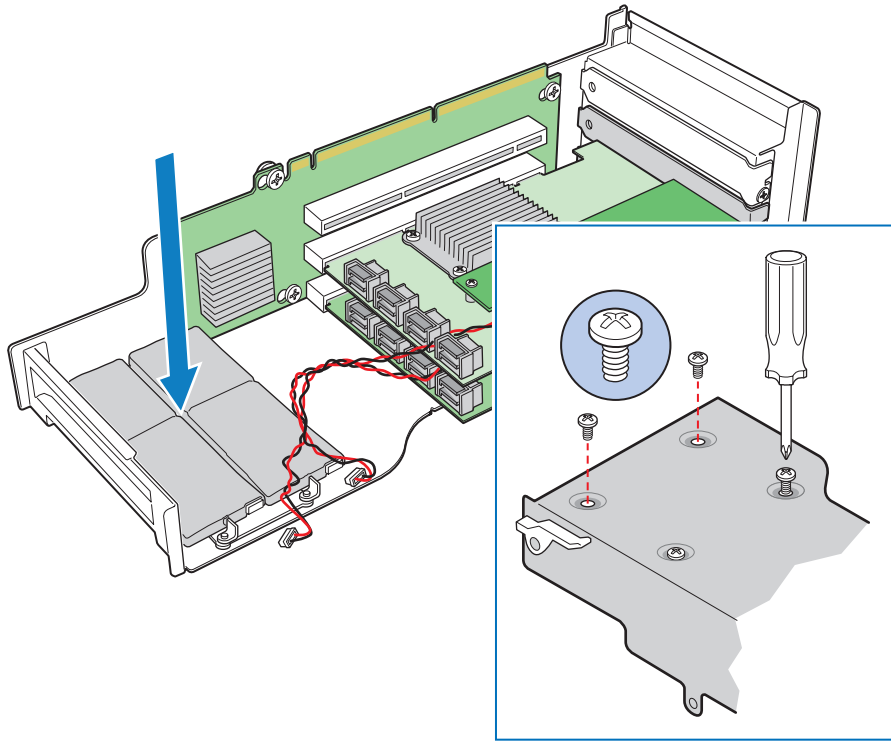
11. Secure the new battery to the battery holder with two screws.



TP02334

**Figure 42. Securing New Battery to Battery Holder**

12. Position the battery holder on the PCI riser assembly and secure the battery holder to the PCI riser assembly with four screws.

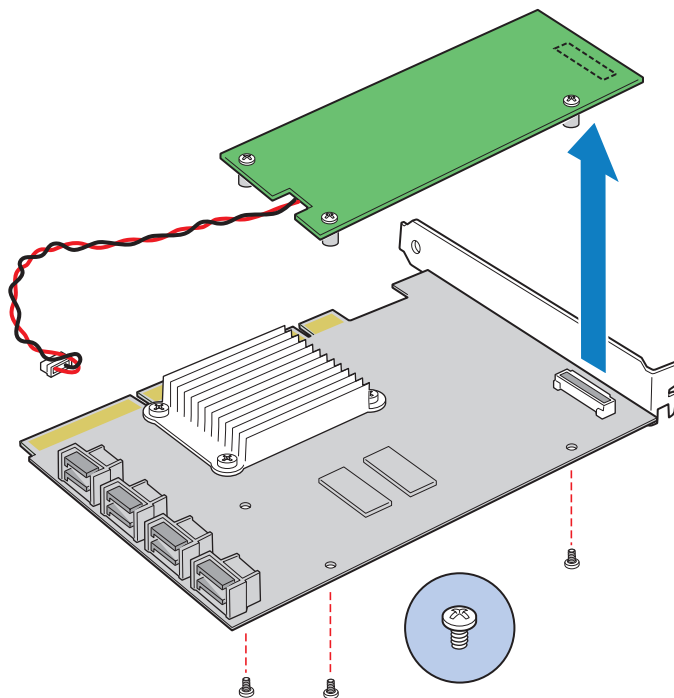


TP02337

**Figure 43. Re-attaching Battery Holder to PCI Riser Assembly**

13. Remove the Intel® RAID Controller with the bad battery from the PCI Riser Assembly. For instructions, see “Removing an Intel® RAID Controller” on page 30.

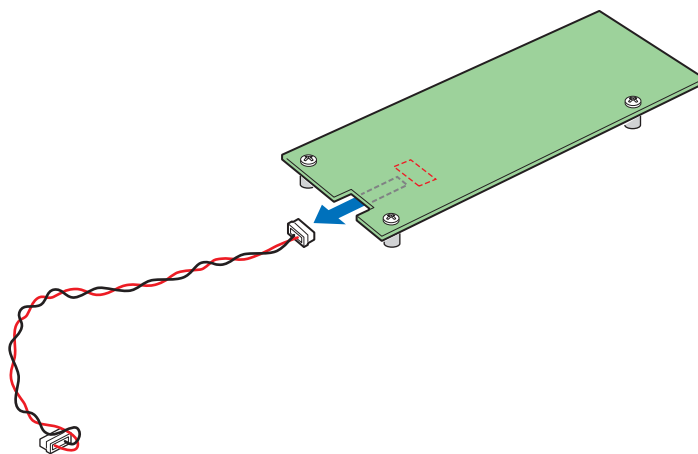
14. Remove the three screws on the bottom side of the Intel® RAID Controller SRCS28X to detach the bad battery backup unit from the card.



TP02338

**Figure 44. Detaching Bad Battery Backup Unit from Intel® RAID Controller**

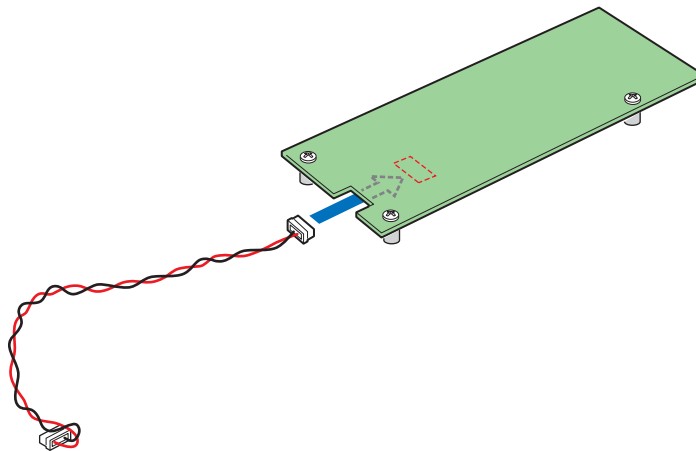
15. Disconnect the extended battery cable from the bad battery backup unit.



TP02339

**Figure 45. Disconnecting Extended Battery Cable from Battery Backup Unit**

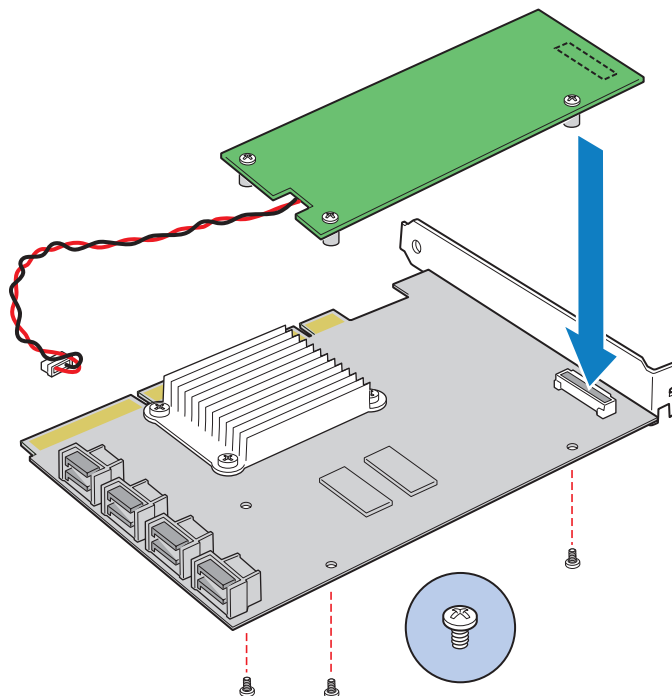
16. Connect the extended battery cable to its connector on the new battery backup unit. The metal contacts of the cable connector should be facing the board. The cable connector will only fit one way and will gently snap into place when fully seated.



TP02340

**Figure 46. Connecting Battery Cable to New Battery Backup Unit**

17. Secure the new backup battery unit to the Intel® RAID Controller with three screws.



TP02341

**Figure 47. Attaching New Battery Backup Unit to Intel® RAID Controller**

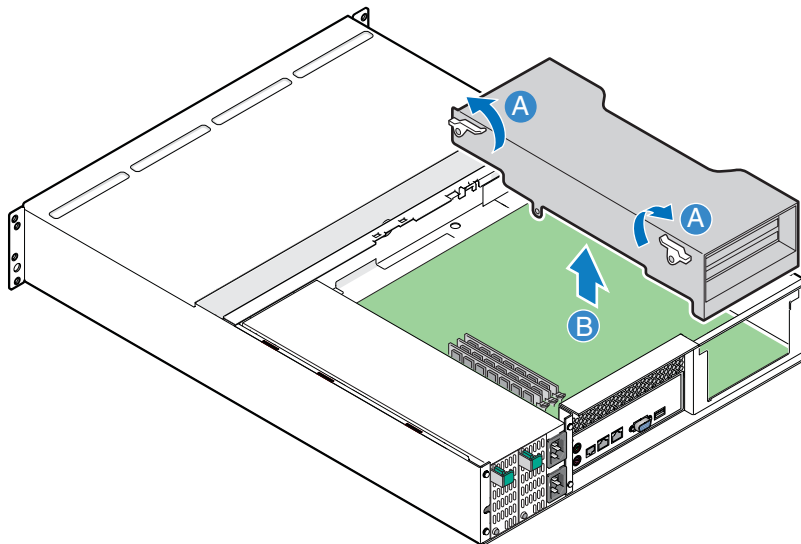
18. Install the Intel® RAID Controller into the PCI riser assembly. For instructions, see “Installing an Intel® RAID Controller” on page 33.

19. Re-install the PCI riser assembly into the chassis. For instructions, see [“Installing the PCI Riser Assembly” on page 25](#).
20. Install the enclosure cover. For instructions, see [“Installing the Enclosure Cover” on page 16](#).
21. Re-connect all peripheral devices and the AC power cable. Power up the storage system.

## Installing a PCI Card

**Caution:** Before performing any maintenance on the system, back up the data. Follow the instructions in the operating system manual for shutting down the system.

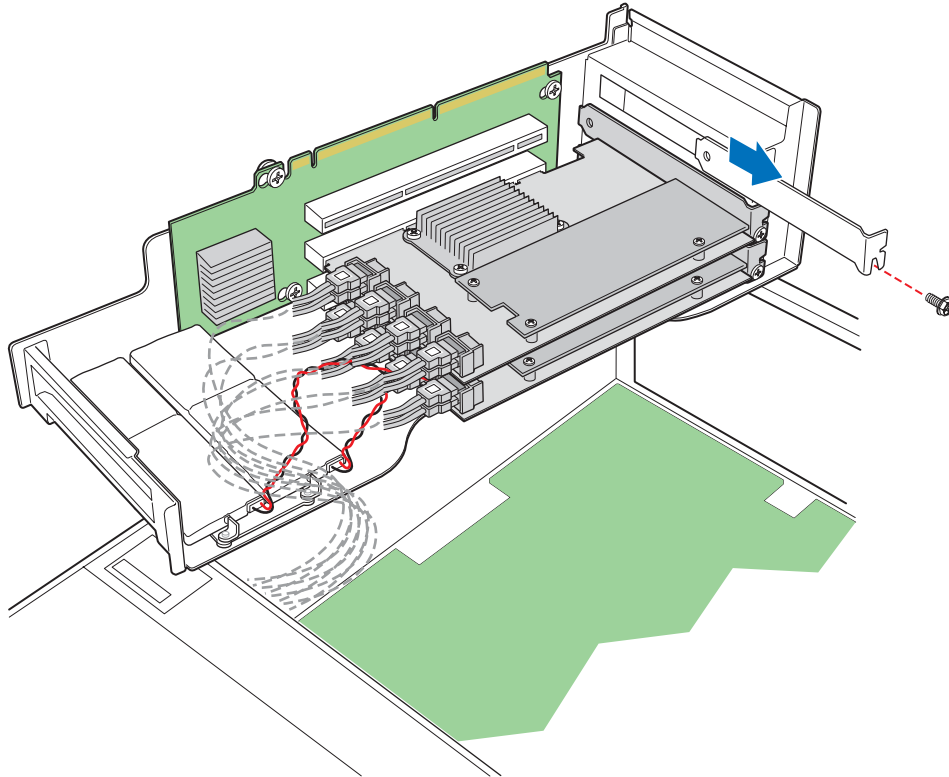
1. Observe all safety and ESD precautions listed in [Appendix D, “Safety Information”](#).
2. Turn off all peripheral devices connected to the storage system. Turn off the storage system.
3. Disconnect the AC power cord(s).
4. Remove the enclosure cover. For instructions, see [“Removing the Enclosure Cover” on page 14](#).
5. Remove the processor air duct. For instructions, see [“Removing the Processor Air Duct” on page 72](#).
6. Unlatch the two levers (see letter “A” in the following figure) on the PCI riser assembly and lift the assembly out of the chassis (see letter “B”).



TP02043

**Figure 48. Removing PCI Riser Assembly from Chassis**

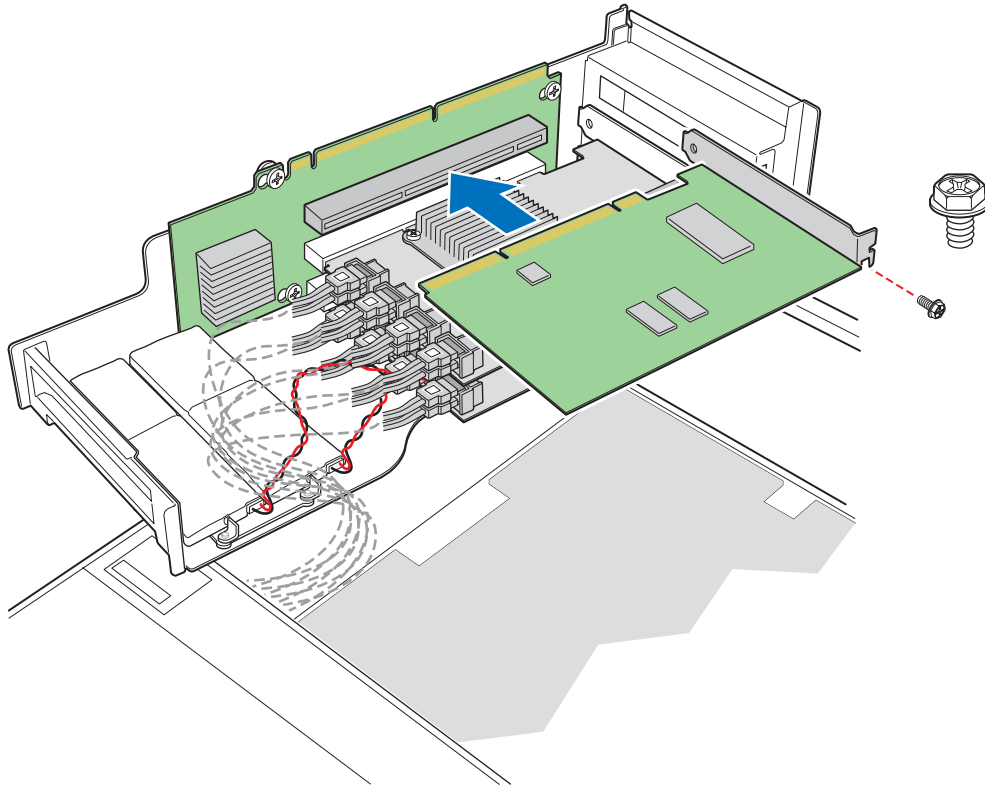
7. Lay the PCI riser assembly upside down across the corner of the chassis. Take care not to unnecessarily pinch the SATA cables. Remove the PCI slot filler.



AF000563

**Figure 49. Removing PCI Slot Filler**

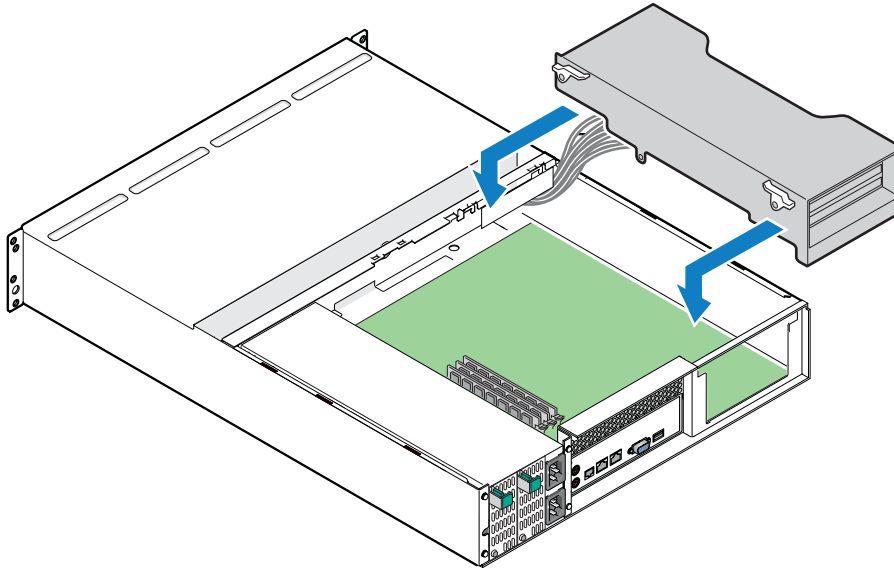
8. Refer to the manufacturer's manual that shipped with the PCI card to configure any necessary jumper settings. Align the PCI card with the connector on the the PCI riser assembly. Press the PCI card firmly into the connector to seat it properly into the PCI slot. Secure the PCI card to the PCI riser assembly with the screw that was removed in the previous step.



AF000564

**Figure 50. Installing PCI Card into PCI Riser Assembly**

9. Match the hooks on the back of the PCI riser assembly with the notches on the cross bar and rear of the chassis. Slide the PCI riser assembly downwards until the PCI riser assembly mates with the connector on the server board. Ensure that you do not pinch any of the SATA cables. The latches should lock into position once the PCI riser assembly is seated properly with the connector on the server board.



TP02055

**Figure 51. Installing PCI Riser Assembly into Chassis**

10. Re-install the processor air duct. For instructions, see [“Installing the Processor Air Duct”](#) on page 73.
11. Re-install the enclosure cover. For instructions, see [“Installing the Enclosure Cover”](#) on page 16.
12. Re-connect all peripheral devices and the AC power cable. Power up the storage system.

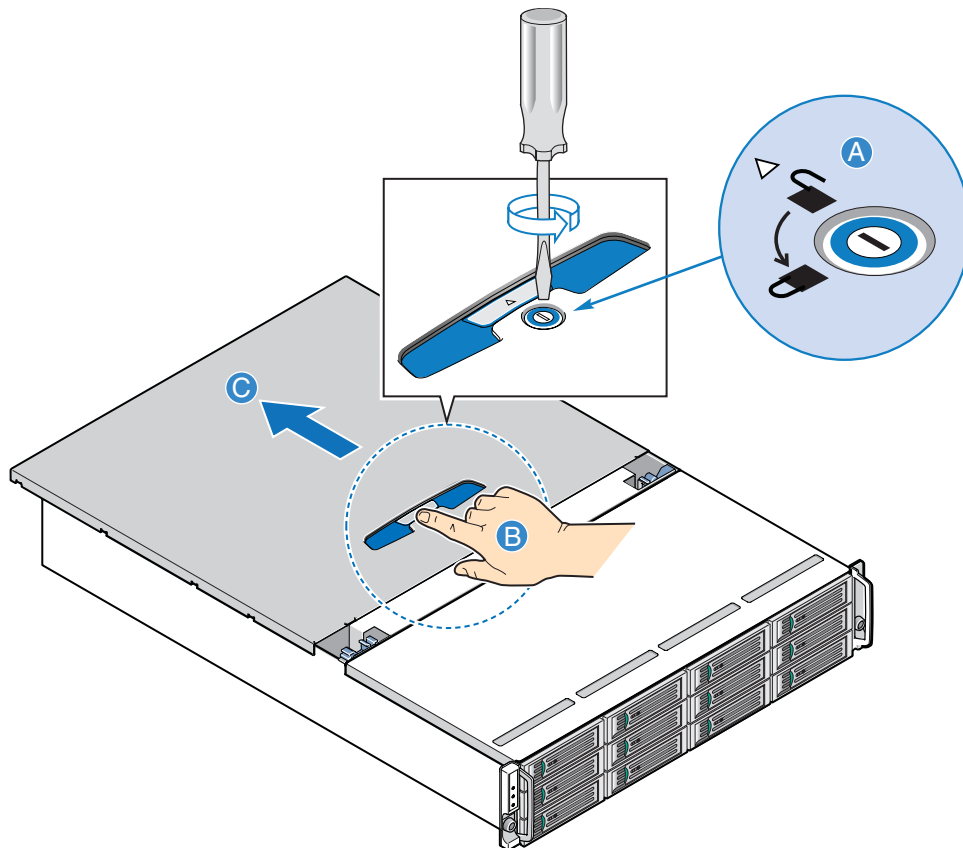


## Hot Swap Replacing, Removing or Installing the Cooling Module

The cooling module is located centrally within the enclosure, installed between the drive bays and the server board.

### Hot Swap Replacing the Cooling Module

1. Observe all safety and ESD precautions listed in [Appendix D, “Safety Information”](#).
2. To access the cooling module location, release the lock by turning the screw a quarter turn until the open lock symbol aligns with the notch in the chassis (see letter “A” in the following figure). Press in on the palm latch (see letter “B”), and slide the enclosure cover back (see letter “C”) until it stops (about 2 inches), revealing the mounting brackets for the cooling module.

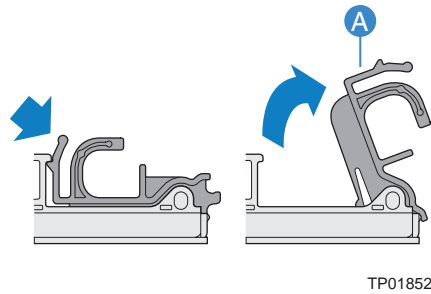


TP01851

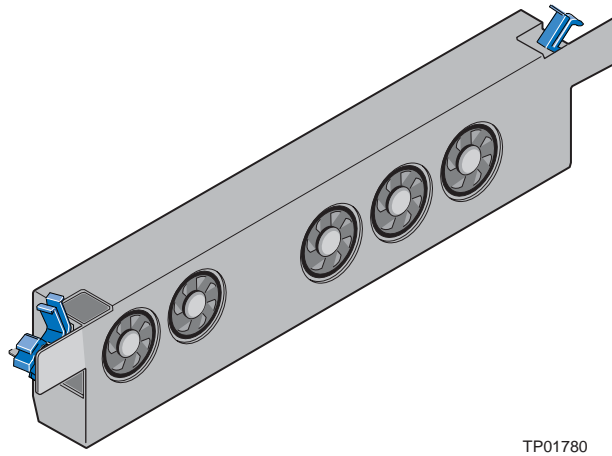
Figure 52. Accessing the Cooling Module

3. Prepare the replacement (new) cooling module by ensuring the latches are in the open position (see letter “A” in the following figure).

**Caution:** The cooling module must be replaced within 30 seconds to ensure the system does not overheat and shut down.

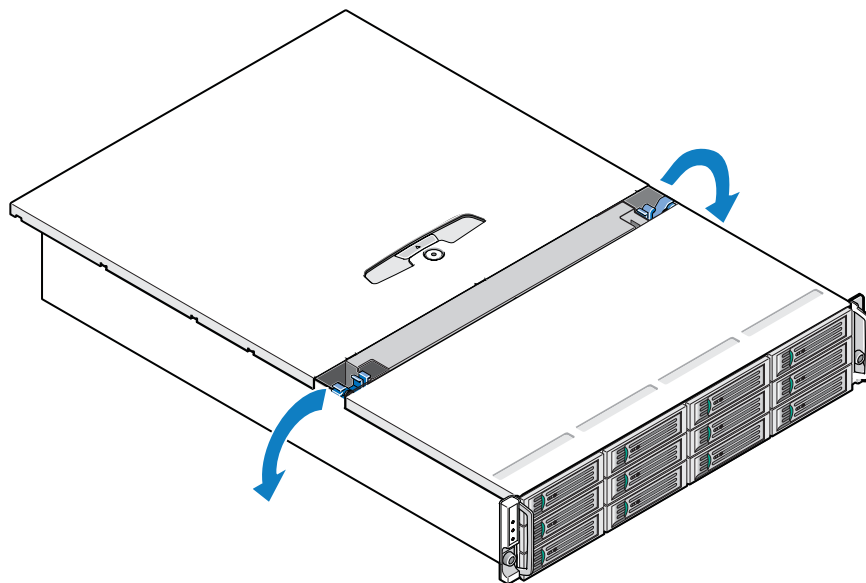


**Figure 53. Opening Cooling Module Latches**



**Figure 54. Cooling Module with Latches in Open Position**

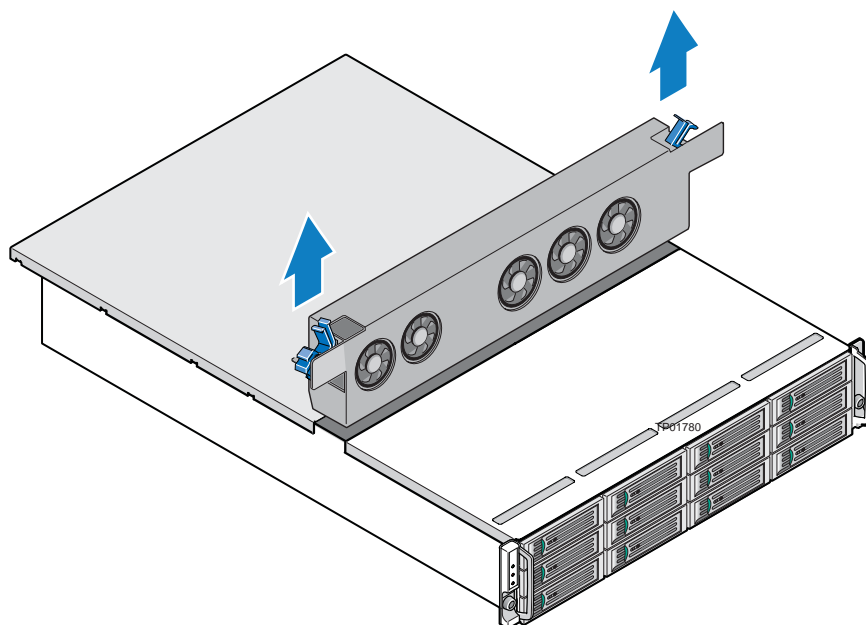
4. Rotate the two latches on the old cooling module to the open position.



TP01860

**Figure 55. Unlatching Cooling Module from Chassis**

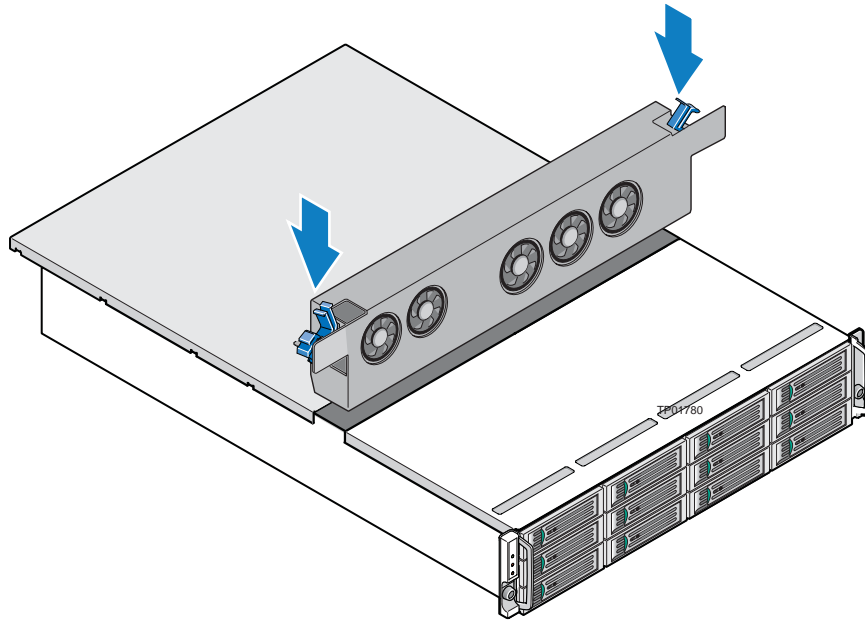
5. With the two latches in the open position, slide the old cooling module out of the enclosure.



TP01858

**Figure 56. Removing Cooling Module from Chassis**

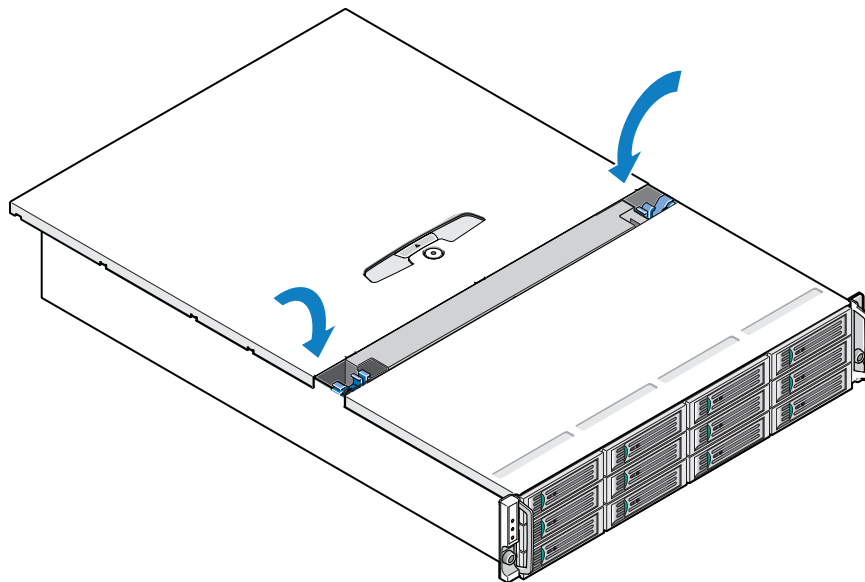
6. With the two latches in the open position, slide the replacement (new) cooling module into the enclosure until the latches engage automatically. This step needs to be completed in less than 30 seconds.



TP01859

**Figure 57. Installing the Cooling Module**

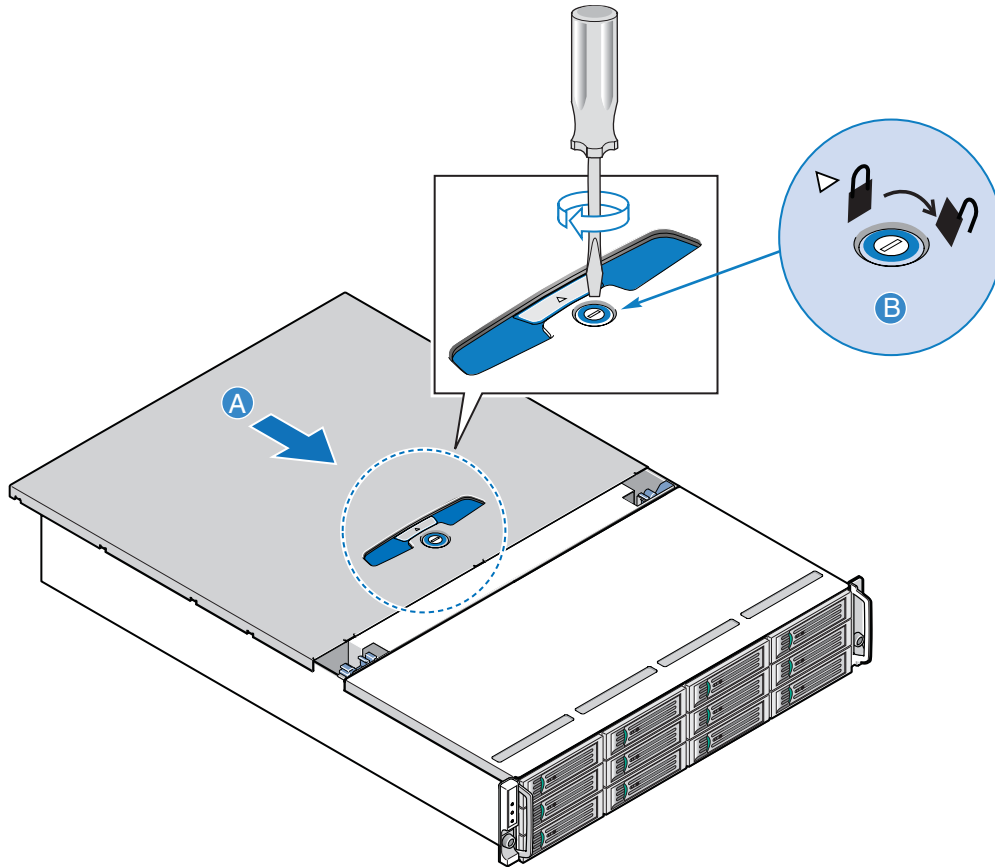
7. Cam the replacement (new) cooling module home by manually closing the latches. A click should be heard as the latches engage.



TP01861

**Figure 58. Latching Cooling Module into Chassis**

8. Close the enclosure cover by sliding it forward (see letter “A” in the following figure). Secure the enclosure cover to the chassis by tightening the lock a quarter turn until the close lock symbol aligns with the notch on the cover (see letter “B”).



TP01773

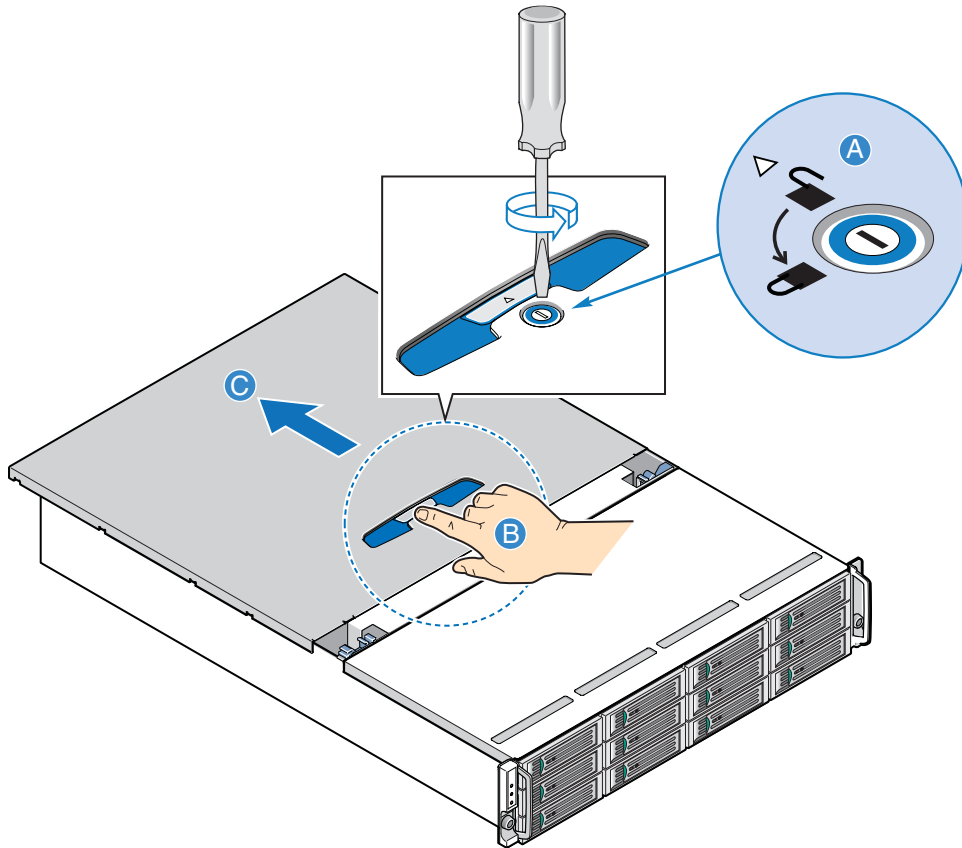
**Figure 59. Closing Enclosure Cover**

## Removing the Cooling Module

**Caution:** Before performing any maintenance on the system, back up the data. Follow the instructions in the operating system manual for shutting down the system.

1. Observe all safety and ESD precautions listed in [Appendix D, “Safety Information”](#).
2. Turn off all peripheral devices connected to the storage system. Turn off the storage system.
3. Disconnect the AC power cord(s).

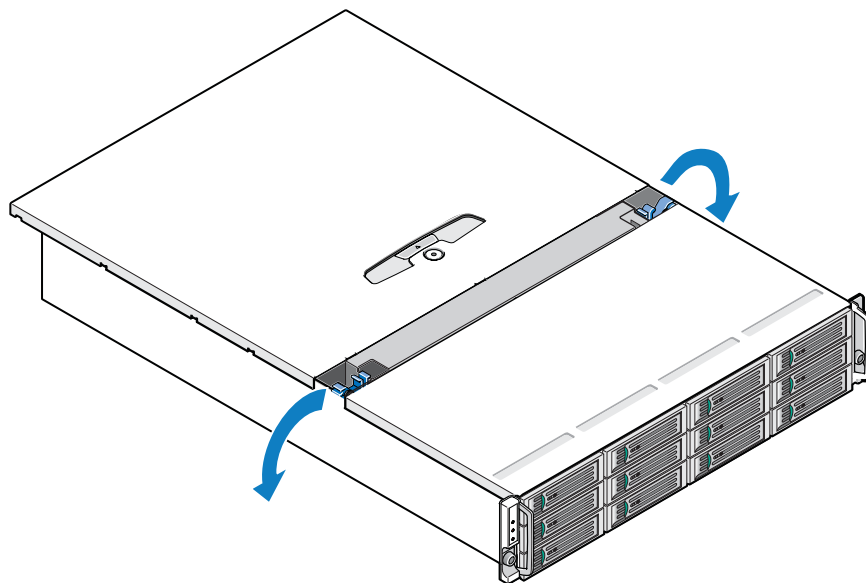
4. To access the cooling module location, release the lock by turning the screw a quarter turn until the open lock symbol aligns with the notch in the chassis (see letter “A” in the following figure). Press in on the palm latch (see letter “B”), and slide the enclosure cover back (see letter “C”) until it stops (about 2 inches), revealing the mounting brackets for the cooling module.



TP01851

**Figure 60. Accessing the Cooling Module**

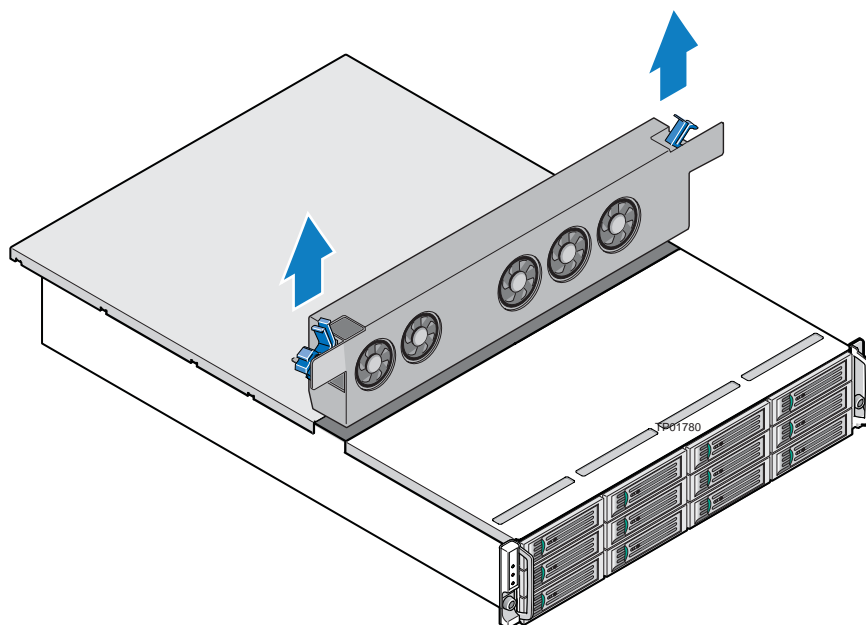
5. Rotate the two latches on the old cooling module to the open position.



TP01860

**Figure 61. Unlatching Cooling Module**

6. With the two latches in the open position, slide the old cooling module out of the enclosure.



TP01858

**Figure 62. Removing Cooling Module**

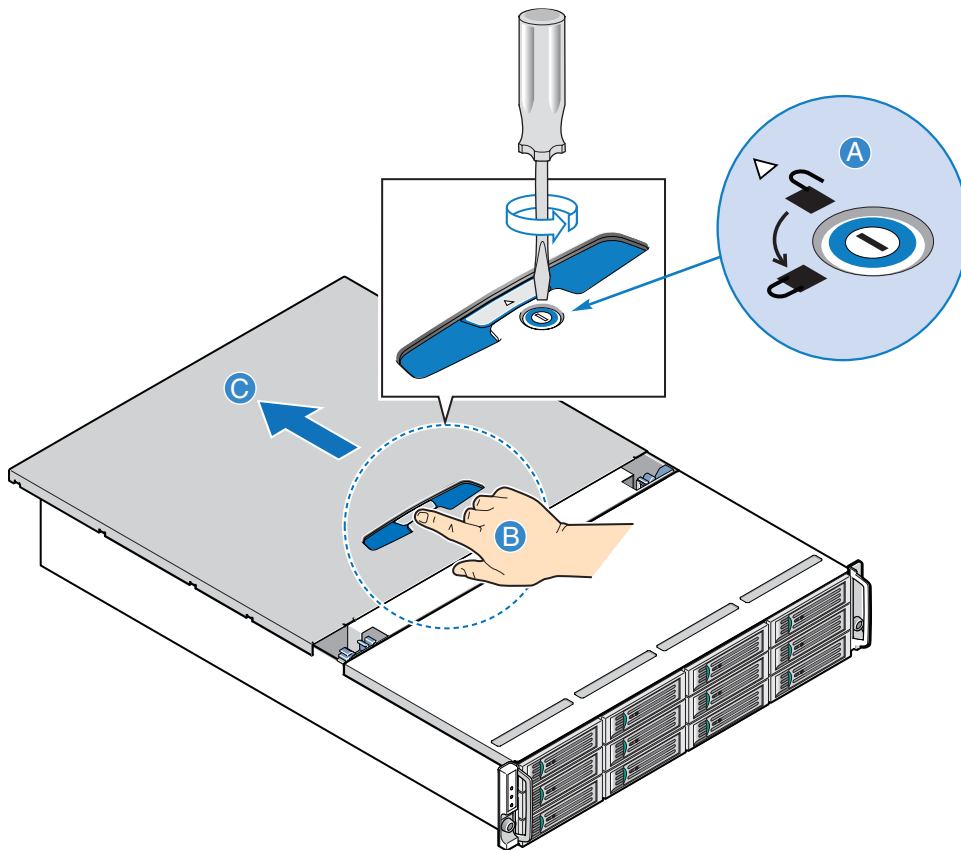
7. If removing the cooling module as part of another procedure, continue with that procedure.

## Installing the Cooling Module

**Caution:** Before performing any maintenance on the system, back up the data. Follow the instructions in the operating system manual for shutting down the system.

**Warning:** Your storage system cannot run without a functional cooling module present. Do not operate your storage system if you are unable to immediately replace a defective cooling module. For instructions on hot swap replacing the cooling module, see “Hot Swap Replacing the Cooling Module” on page 47.

1. Observe all safety and ESD precautions listed in [Appendix D, “Safety Information”](#).
2. To access the cooling module location, release the lock by turning the screw a quarter turn until the open lock symbol aligns with the notch in the chassis (see letter “A” in the following figure). Press in on the palm latch (see letter “B”), and slide the enclosure cover back (see letter “C”) until it stops (about 2 inches), revealing the mounting brackets for the cooling module.

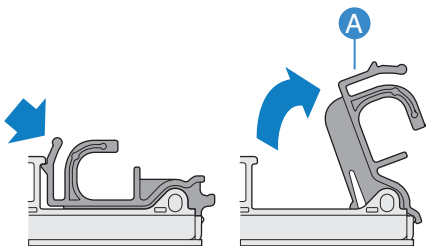


TP01851

**Figure 63. Accessing the Cooling Module**

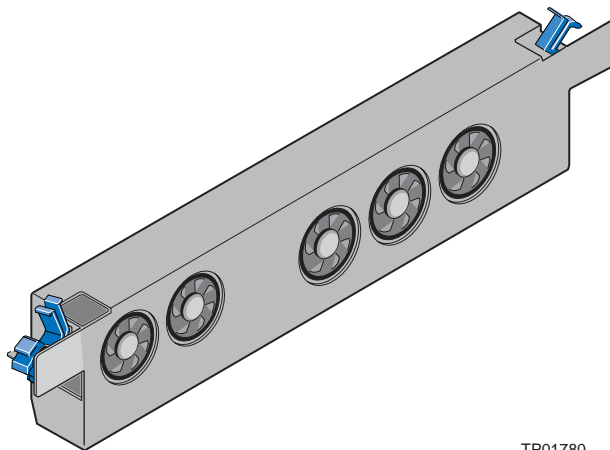


3. Position the cooling module latches in the open position (see letter “A” in the following figure) on the cooling module.



TP01852

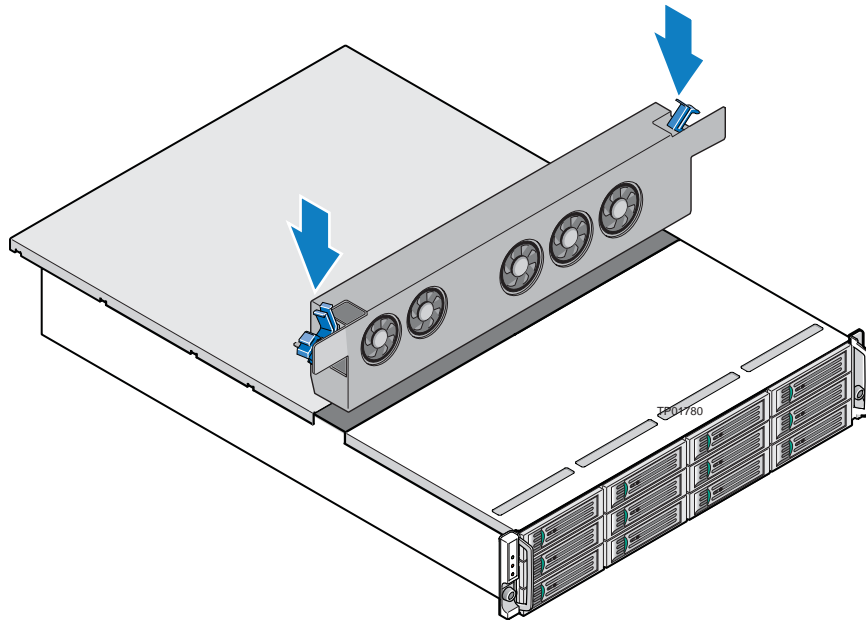
**Figure 64. Opening Cooling Module Latches**



TP01780

**Figure 65. Cooling Module with Latches in Open Position**

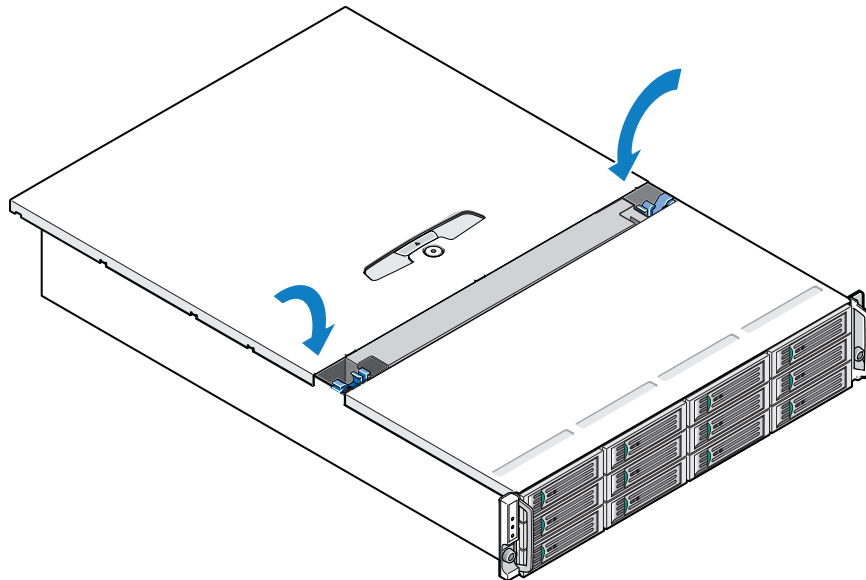
4. With the two latches in the open position, slide the cooling module into the enclosure until the latches engage automatically.



TP01859

**Figure 66. Inserting Cooling Module into Chassis**

5. Cam the module home by manually closing the latches. A click should be heard as the latches engage.



TP01861

**Figure 67. Closing Latches on Cooling Module**

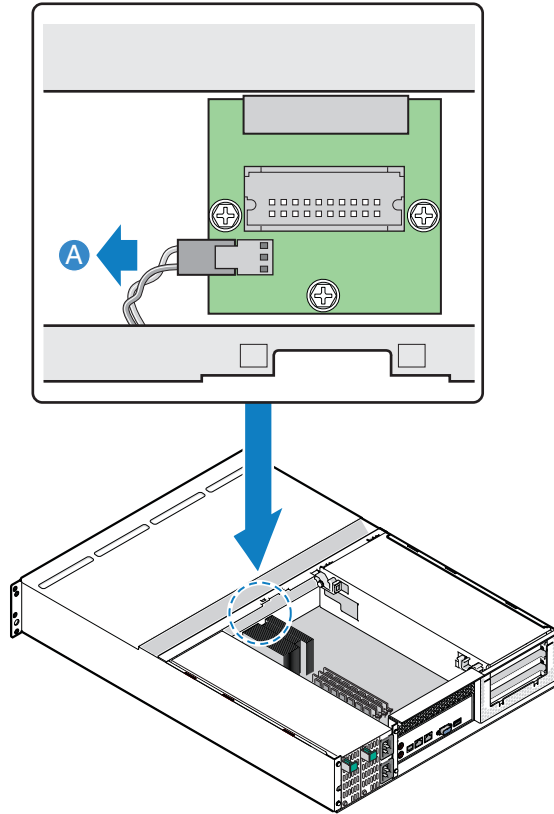
6. If installing a cooling module as part of another procedure, continue with that procedure.

## Replacing the Fan Interposer Board

**Caution:** *Before performing any maintenance on the system, back up the data. Follow the instructions in the operating system manual for shutting down the system.*

1. Observe all safety and ESD precautions listed in [Appendix D, “Safety Information”](#).
2. Turn off all peripheral devices connected to the storage system. Turn off the storage system.
3. Disconnect the AC power cord(s).
4. Remove the enclosure cover. For instructions, see [“Removing the Enclosure Cover” on page 14](#).
5. Remove the cooling module. For instructions, see [“Removing the Cooling Module” on page 51](#).

6. Disconnect the IPMB cable from the old fan interposer board (see letter “A” in the following figure).

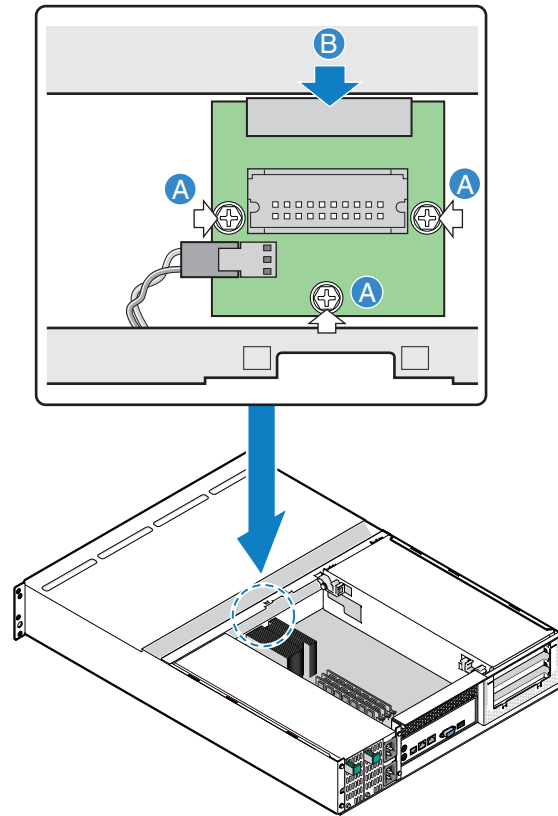


TP01868

**Figure 68. Disconnecting IPMB Cable from Fan Interposer Board**

7. Remove the three screws (see letter “A” in the following figure) securing the old fan interposer board to the chassis. The power cable bundle may have to be moved aside slightly to expose all the screws. Disconnect the old fan interposer board (see letter “B”) from its connector on the backplane.

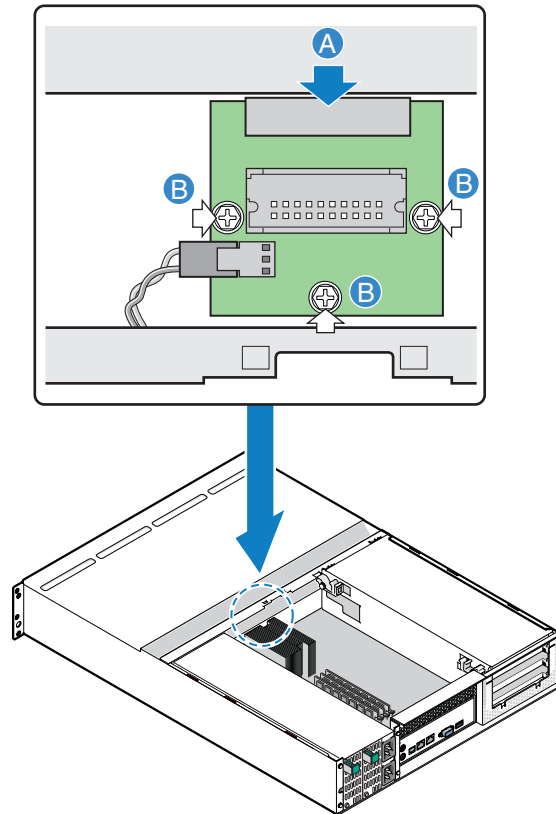
**Caution:** Do not operate your storage system without a functioning fan interposer board installed in the system.



TP02007

**Figure 69. Removing Fan Interposer Board from Chassis**

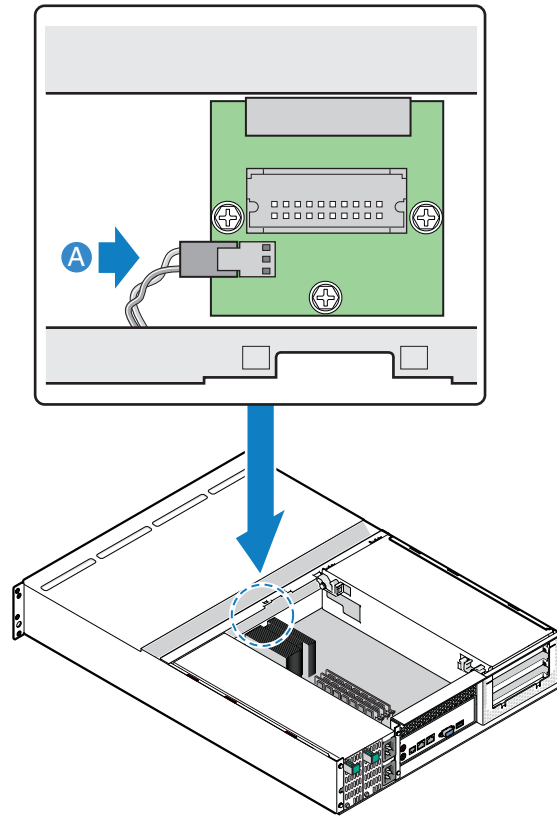
8. Connect the new fan interposer board to its connector on the backplane (see letter “A” in the following figure). Secure the fan interposer board to the chassis with three screws (see letter “B”).



TP02009

**Figure 70. Securing Fan Interposer Board to Chassis**

9. Connect the IPMB cable to the new fan interposer board (see letter “A” in the following figure).



TP02008

### Figure 71. Connecting IPMB Cable to Fan Interposer Board

10. Install the cooling module. For instructions, see [“Installing the Cooling Module” on page 54](#).
11. Install the enclosure cover. For instructions, see [“Installing the Enclosure Cover” on page 16](#).
12. Re-connect all peripheral devices and the AC power cable. Power up the storage system.

## Removing or Installing a Drive Carrier

### Planning Your Drive Carrier Configuration

**Important:** When planning your system configuration, remember that all enclosure drive bays must be filled with either a filled or empty drive carrier; no bays should be left completely empty.

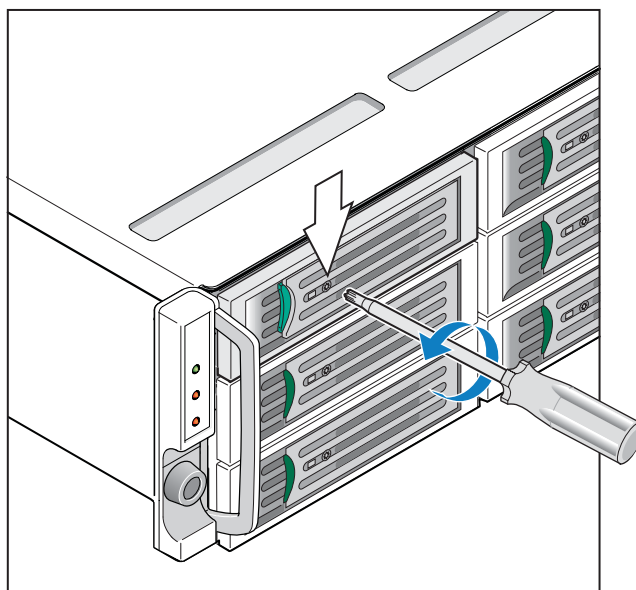
**Important:** Before you begin installation you should become familiar with the configuration requirements of your Intel® Storage System SSR212CC. Refer to “[Planning Your Installation](#)” on page 11 for information on your overall system configurations.

### Removing a Drive Carrier

**Caution:** Before performing any maintenance on the system, back up the data. Follow the instructions in the operating system manual for shutting down the system.

**Caution:** Damage can occur to a drive if a drive is removed while still spinning. If possible, use the storage system console software to spin down and power down the drive prior to removal. If this is not possible, wait 30 seconds after releasing the drive carrier from the chassis to ensure the drive has spun down prior to removal.

1. Observe all safety and ESD precautions listed in [Appendix D, “Safety Information”](#)
2. Use a #10 torque screwdriver to turn the screw on the front of the drive carrier a **half** a turn.



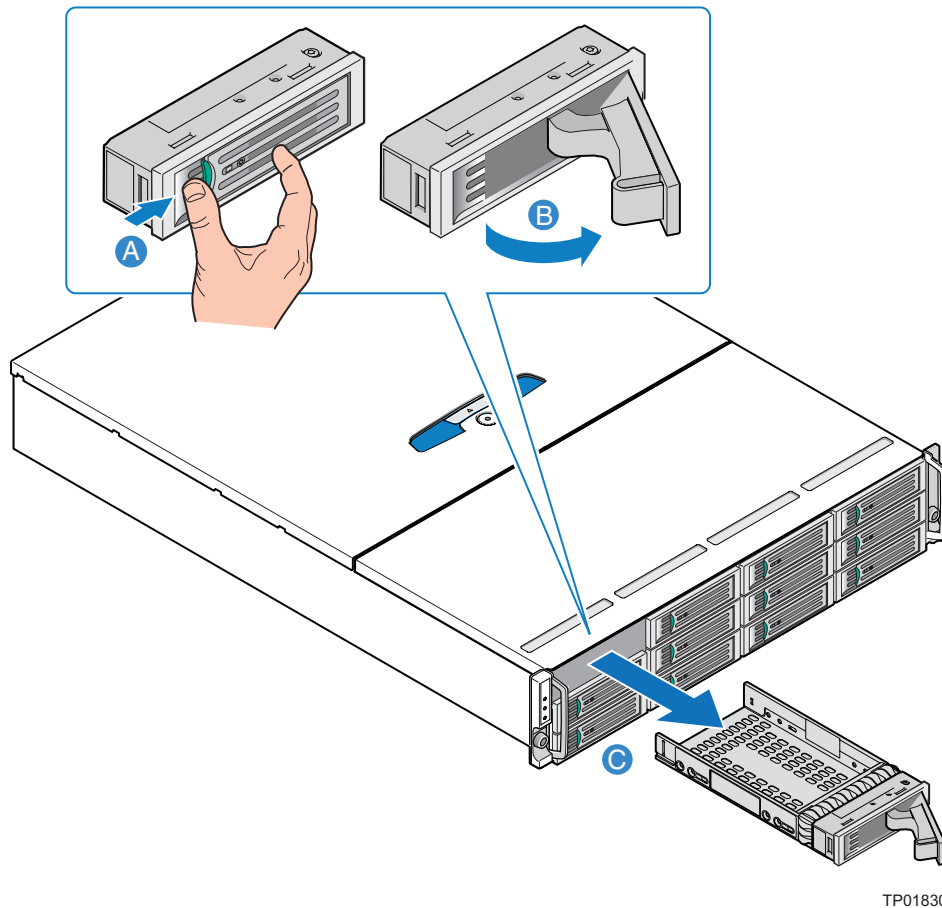
TP01854

**Figure 72. Releasing Screw from Front of Drive Carrier**

3. Release the drive carrier from the drive bay by pressing the latch in the handle towards the handle hinge (see letter “A” in the following figure). Once the drive



carrier is unlatched (see letter “B”), slide the drive carrier out of the drive bay (see letter “C”).



TP01830

**Figure 73. Removing Drive Carrier from Drive Bay**

4. If installing a hard drive, see [“Installing a Drive Carrier”](#) on page 63 for instructions on installing a hard drive into a drive carrier.
5. If removing a hard drive, see [“Removing a Hard Drive from a Drive Carrier”](#) on page 65 for instructions on removing a hard drive from a drive carrier.
6. See [“Installing a Drive Carrier”](#) on page 63 for instructions on installing a drive carrier into a drive bay.

## Installing a Drive Carrier

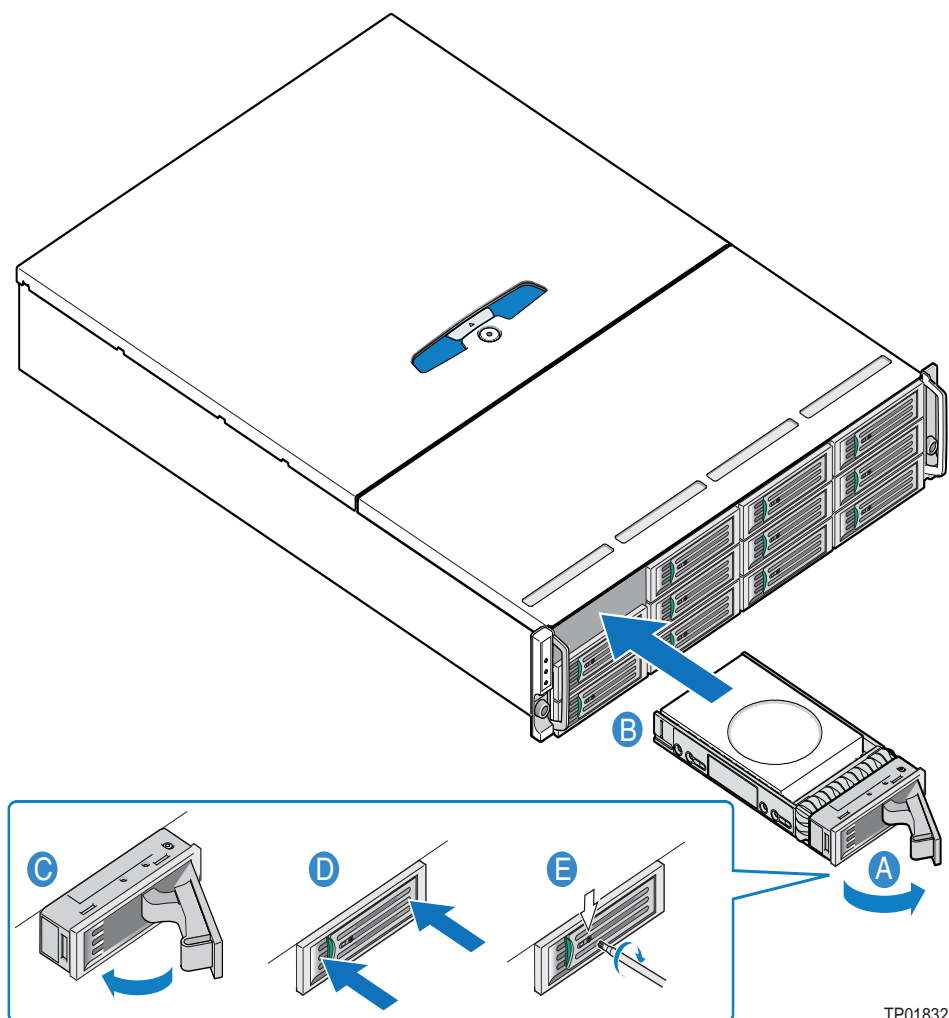
**Caution:** Before performing any maintenance on the system, back up the data. Follow the instructions in the operating system manual for shutting down the system.

**Caution:** An empty drive carrier **MUST** be fitted in **ALL** unused drive bays. There will be inadequate drive cooling if any drive bays are left open.

1. Observe all safety and ESD precautions listed in [Appendix D, “Safety Information”](#)

2. Release the drive carrier handle, by depressing the latch in the handle (see letter “A” in the following figure). Slide the drive carrier into the drive bay (see letter “B”). Continue to push firmly until the handle fully engages and closes (see letter “C”). A click should be heard as the latch engages and holds the handle closed. Press in on both sides of the drive (see letter “D”) to ensure the drive is seated properly and makes a good connection with the backplane. Secure the drive carrier to the chassis by tightening the screw on the front of the drive carrier a half a turn with a #10 TORX\* screwdriver (see letter “E”). This prevents inadvertent removal of the hard drive.
3. Install the appropriate drive label on the indent to the right side of the drive carrier. See [Figure 92](#) for drive bay numbering order.

**Important:** Ensure that the carrier is orientated so that the drive is uppermost and the handle opens from the left.

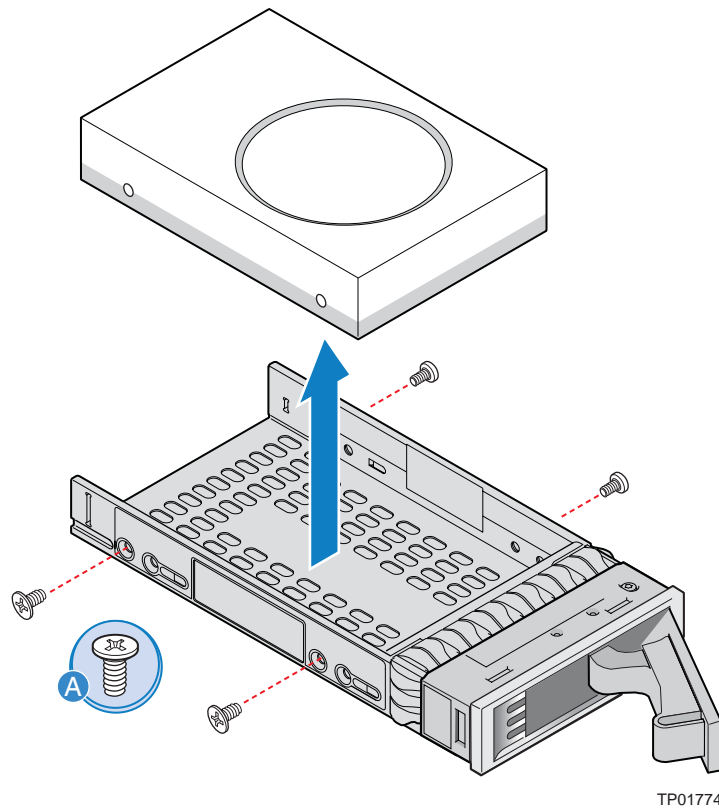


**Figure 74. Installing Drive Carrier into Drive Bay**

## Removing or Installing a Hard Drive into a Drive Carrier

### Removing a Hard Drive from a Drive Carrier

1. Observe all safety and ESD precautions listed in [Appendix D, “Safety Information”](#).
2. See [“Removing a Drive Carrier” on page 62](#) for instructions on removing a drive carrier from a drive bay.
3. Remove the four screws securing the hard drive to the drive carrier (see letter “A” in the following figure). Lift the hard drive out of the drive carrier.

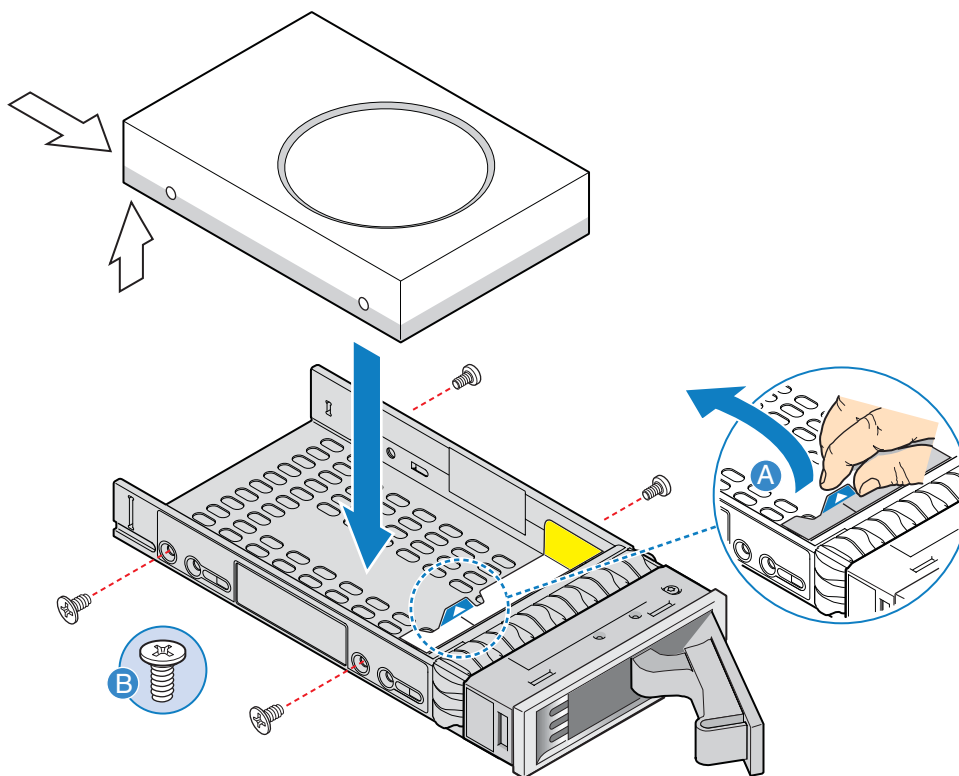


**Figure 75. Removing Hard Drive from Drive Carrier**

4. If replacing the hard drive, see [“Installing a Hard Drive into a Drive Carrier” on page 66](#) for instructions on installing a hard drive into a drive carrier. If not replacing the hard drive, ensure that a blank drive carrier is fitted in the drive bay.
5. For instructions on re-installing the drive carrier into the drive bay, see [“Installing a Drive Carrier” on page 63](#).

## Installing a Hard Drive into a Drive Carrier

1. Observe all safety and ESD precautions listed in [Appendix D, “Safety Information”](#).
2. See [“Removing a Drive Carrier” on page 62](#) for instructions on removing a drive carrier from a drive bay.
3. If replacing a hard drive, see [“Removing a Hard Drive from a Drive Carrier” on page 65](#) for instructions on removing a hard drive from a drive carrier.
4. If not previously removed, remove the label from the inside of the drive carrier by pulling up on the blue tab (see letter “A” in the following figure). Insert hard drive into drive carrier, ensuring that the top of the hard drive faces up and the connector end of the hard drive faces the rear of the drive carrier. Secure the hard drive to the drive carrier with four screws (see letter “B”).



TP01829

**Figure 76. Installing Hard Drive in Drive Carrier**

5. For instructions on re-installing the drive carrier into the drive bay, see [“Installing a Drive Carrier” on page 63](#).

## Replacing an Intel® Server Board SE7520JR2

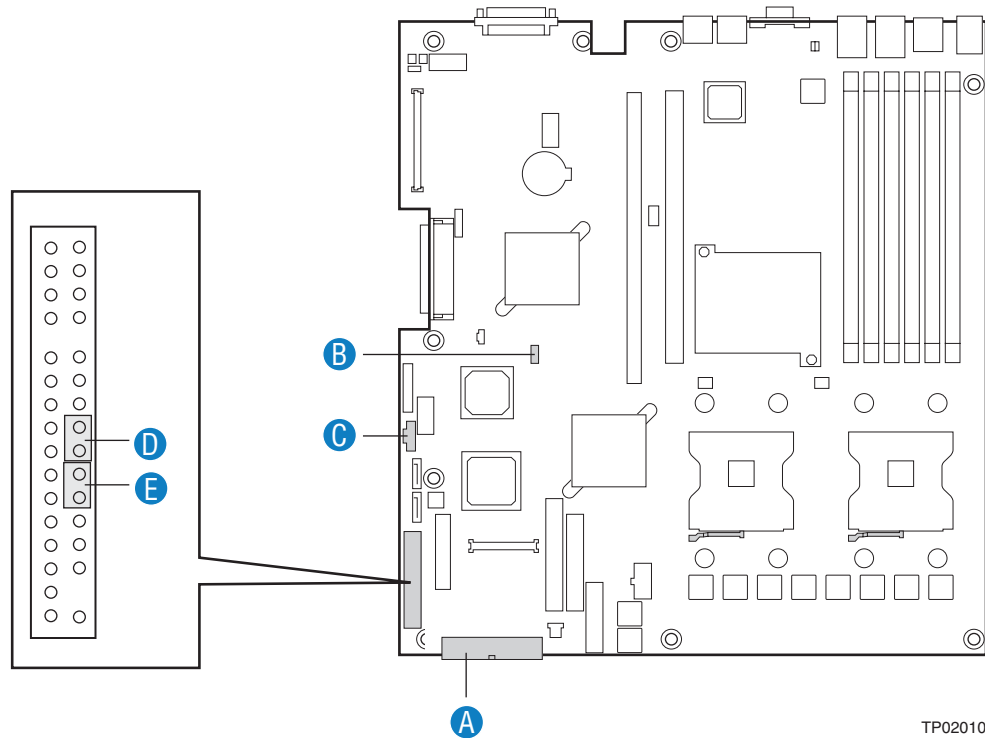
**Caution:** Before performing any maintenance on the system, back up the data.

**Caution:** Before installing a new server board, ensure that the server board has the correct versions of the BIOS, FRU/SDR and mBMC installed. Refer to the support site at <http://www.intel.com/support/motherboards/server/ssr212cc> for the appropriate firmware version to use.

### Removing a Server Board

1. Observe all safety and ESD precautions listed in [Appendix D, “Safety Information”](#).
2. Turn off all peripheral devices connected to the storage system. Turn off the storage system.
3. Disconnect the AC power cord(s).
4. Remove the enclosure cover. For instructions, see [“Removing the Enclosure Cover” on page 14](#).
5. Remove the cooling module. For instructions, see [“Removing the Cooling Module” on page 51](#).
6. Remove the processor air duct. For instructions, see [“Removing the Processor Air Duct” on page 72](#).
7. Remove the PCI riser assembly. For instructions, see [“Removing the PCI Riser Assembly” on page 22](#).
8. Remove the heat sink and processor. For instructions, see [“Removing the Processor” on page 74](#).
9. Remove the memory DIMMs. For instructions, see [“Removing DIMMs” on page 91](#).

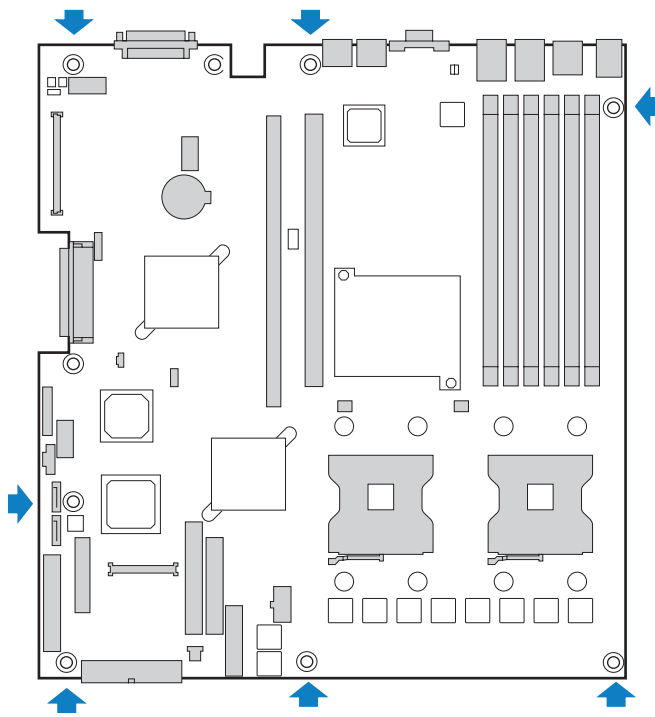
10. Disconnect the main power cable from the server board (see letter “A” in the following figure). Disconnect the IPMB cable (see letter “B”). Disconnect the P3 power supply signal cable (see letter “C”). Disconnect the reset (see letter “D”) and power switch (see letter “E”) cables.



**Figure 77. Disconnecting Cables from Server Board**

11. Remove the IMM Pro module. For instructions, see “[Removing the IMM Pro Module](#)” on page 94.

12. Remove the seven screws securing the server board to the chassis. Remove server board from chassis and store in an anti-static bag.

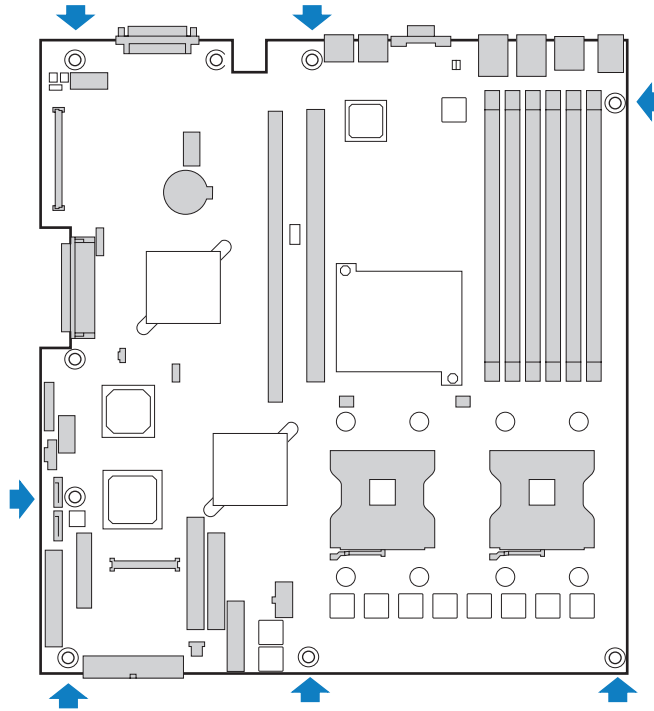


TP02012

**Figure 78. Removing Server Board from Chassis**

## Installing a Server Board

1. Install the new server board by aligning the screw holes in the server board with the standoffs in the chassis.



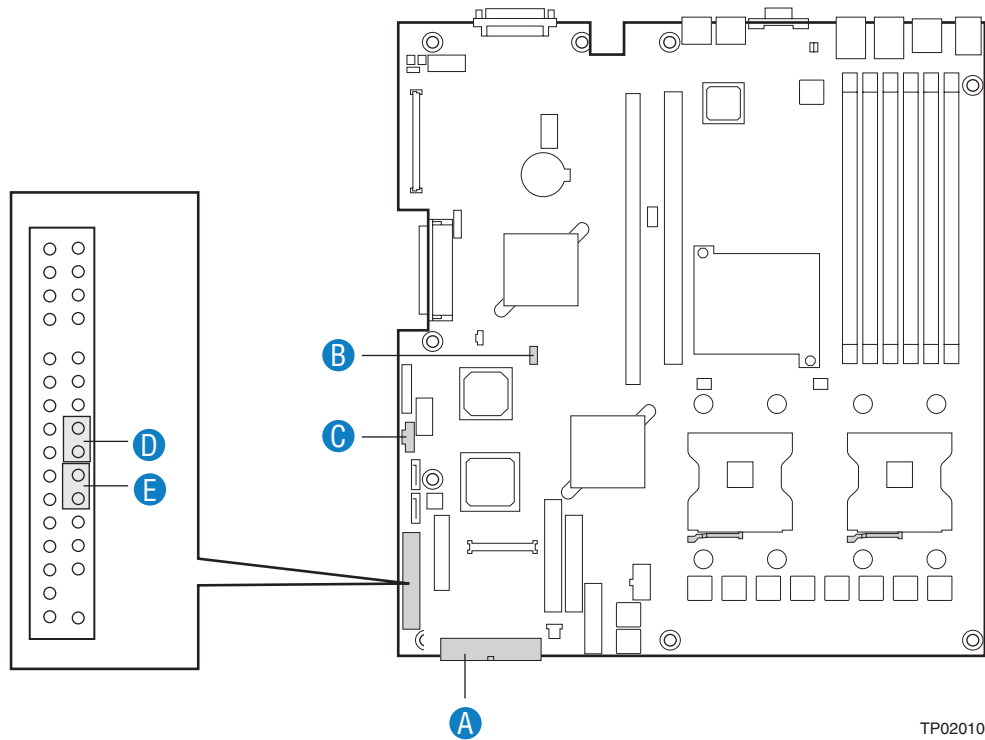
TP02012

**Figure 79. Installing Server Board in Chassis**

2. Install the processor and heatsink. For instructions, see “Installing the Processor” on page 76.
3. Install the memory DIMMs. For instructions, see “Installing DIMMs” on page 93.



4. Connect the main power cable to the server board (see letter “A” in the following figure). Connect the IPMB cable (see letter “B”). Connect the P3 power supply signal cable (see letter “C”). Connect the reset (see letter “D”) and power switch (see letter “E”) cables.



**Figure 80. Connecting Cables to Server Board**

5. Install the IMM Pro module. For instructions, see [“Installing the IMM Pro Module” on page 98](#).
6. Install the PCI riser assembly. For instructions, see [“Installing the PCI Riser Assembly” on page 25](#).
7. Install the processor air duct. For instructions, see [“Installing the Processor Air Duct” on page 73](#).
8. Install the cooling module. For instructions, see [“Installing the Cooling Module” on page 54](#).
9. Install the enclosure cover. For instructions, see [“Installing the Enclosure Cover” on page 16](#).
10. Re-connect all peripheral devices and the AC power cable.

## Removing or Installing the Processor Air Duct

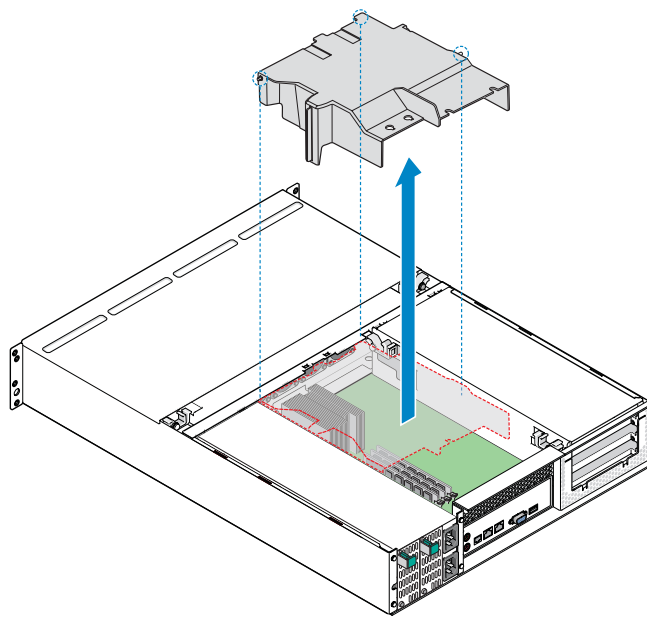
Always operate your storage system with the processor air duct in place. The air duct is required to maintain proper cooling of the processors. The air dam on the processor air duct is required for proper airflow and should never be removed.

For instructions on adding or replacing a processor, see [“Removing or Installing the Processor” on page 74](#). Return to these instructions to re-install the processor air duct after installing your processor and heatsink.

### Removing the Processor Air Duct

**Caution:** Before performing any maintenance on the system, back up the data. Follow the instructions in the operating system manual for shutting down the system.

1. Observe all safety and ESD precautions listed in [Appendix D, “Safety Information”](#).
2. Turn off all peripheral devices connected to the storage system. Turn off the storage system.
3. Disconnect the AC power cord(s).
4. Remove the enclosure cover. For instructions, see [“Removing the Enclosure Cover” on page 14](#).
5. Lift the processor air duct from its location over the processor socket(s).



TP01856

**Figure 81. Removing Processor Air Duct**

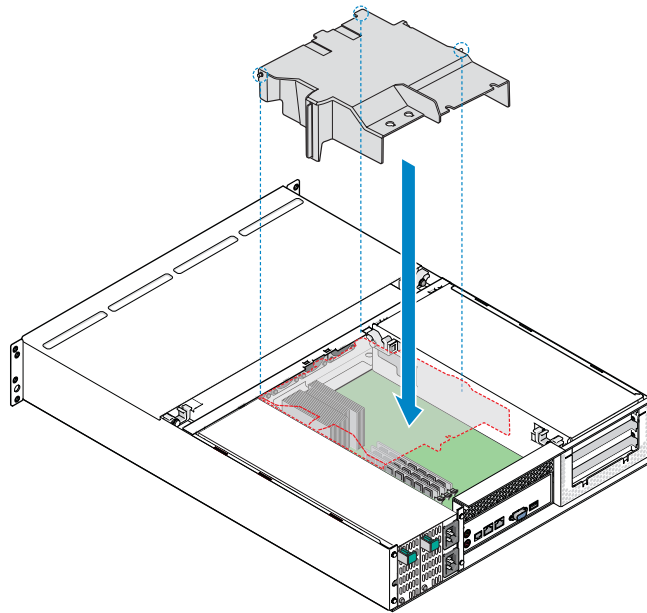
6. If removing a processor air duct as part of another procedure, continue with that procedure.

## Installing the Processor Air Duct

**Caution:** Before performing any maintenance on the system, back up the data. Follow the instructions in the operating system manual for shutting down the system.

**Warning:** Do not operate the Intel® Storage System SSR212CC without the presence of a processor air duct.

1. Observe all safety and ESD precautions listed in [Appendix D, “Safety Information”](#).
2. Disconnect all peripheral devices connected to the storage system.
3. Disconnect the AC power cord(s).
4. Remove the enclosure cover. For instructions, see [“Removing the Enclosure Cover” on page 14](#).
5. Install the processor air duct.



TP01855

**Figure 82. Installing Processor Air Duct**

## Removing or Installing the Processor

The Intel® Storage System SSR212CC does not support a two-processor configuration. The current system only supports a single low-voltage Intel® Xeon® 2.8 GHz processor with an 800-MHz system bus and 1-MB L2 cache.

**Caution:** *You may damage the server board if you install a processor that is inappropriate for your server board.*

**Caution:** *Reduce the risk of electrostatic discharge (ESD) damage to the processor by doing the following:*

*(1) Touch the metal chassis before touching the processor or server board. Keep part of your body in contact with the metal chassis to dissipate the static charge while handling the processor.*

*(2) Avoid moving around unnecessarily.*

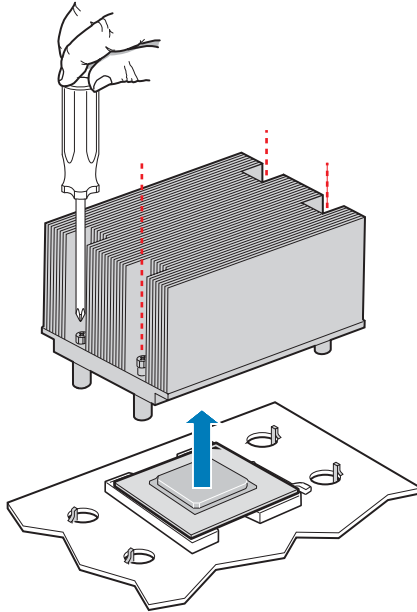
## Removing the Processor

**Caution:** *Before performing any maintenance on the system, back up the data. Follow the instructions in the operating system manual for shutting down the system.*

1. Observe all safety and ESD precautions listed in [Appendix D, “Safety Information”](#).
2. Turn off all peripheral devices connected to the storage system. Turn off the storage system.
3. Disconnect the AC power cord(s).
4. Remove the enclosure cover. For instructions, see [“Removing the Enclosure Cover” on page 14](#).
5. Remove the processor air duct. For instructions, see [“Removing the Processor Air Duct” on page 72](#).

6. Loosen the four captive screws on the corners of the heatsink. Twist the heatsink slightly to break the seal between the heatsink and the processor. Lift the heatsink from the processor. If it does not pull up easily, twist the heatsink again.

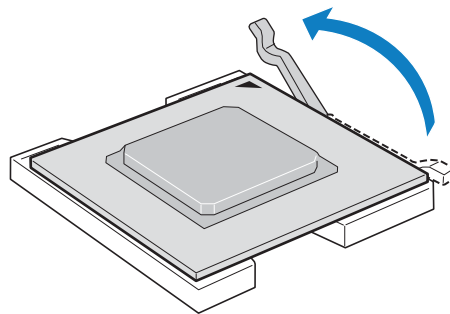
**Caution:** Do not force the heatsink from the processor. Doing so could damage the processor.



TP01775

**Figure 83. Removing Heatsink**

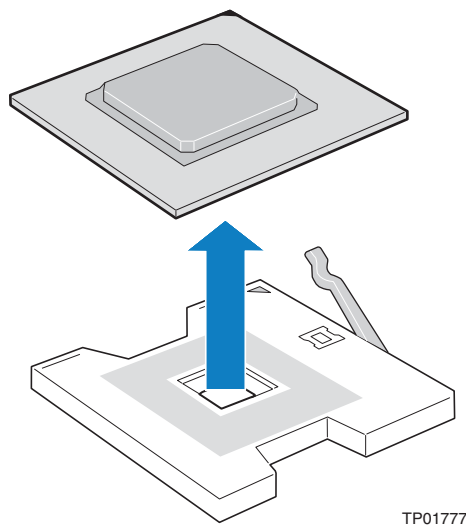
7. Lift the processor lever.



TP01776

**Figure 84. Opening Socket Lever**

8. Remove the processor.



TP01777

**Figure 85. Removing Processor**

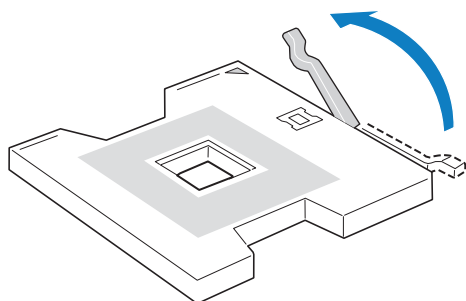
9. Re-install a replacement processor. For instructions, see [“Installing the Processor”](#) on page 76.
10. Re-install the processor air duct. For instructions, see [“Installing the Processor Air Duct”](#) on page 73.
11. Re-install the enclosure cover. For instructions, see [“Installing the Enclosure Cover”](#) on page 16.
12. Re-connect all peripheral devices and the AC power cable. Power up the storage system.

## Installing the Processor

**Caution:** Before performing any maintenance on the system, back up the data. Follow the instructions in the operating system manual for shutting down the system.

1. Observe all safety and ESD precautions listed in [Appendix D, “Safety Information”](#).
2. Turn off all peripheral devices connected to the storage system. Turn off the storage system.
3. Disconnect the AC power cord(s).
4. Remove the enclosure cover. For instructions, see [“Removing the Enclosure Cover”](#) on page 14.
5. Remove the processor air duct. For instructions, see [“Removing the Processor Air Duct”](#) on page 72.

6. Locate the processor socket and raise the socket handle completely.

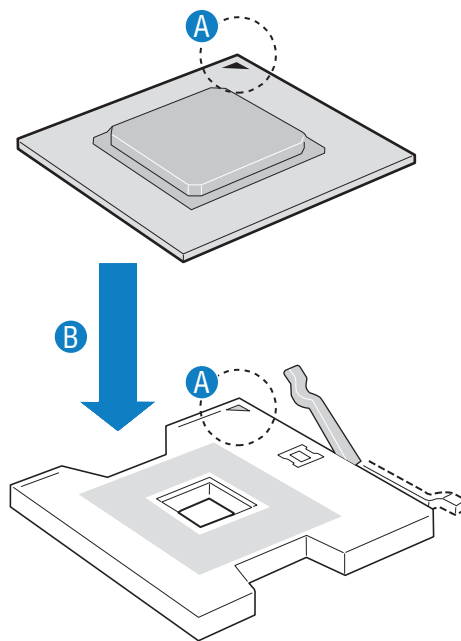


TP00763

**Figure 86. Opening Socket Lever**

7. Align the pins of the processor with the socket, and insert the processor into the socket.

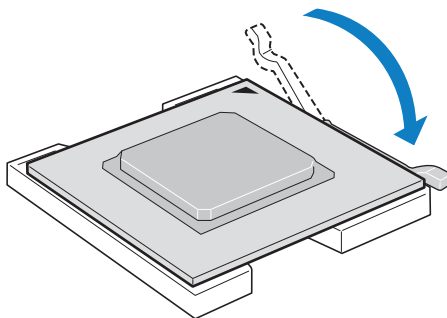
**Note:** Make sure the alignment triangle mark and the alignment triangle cut-out align correctly.



TP00764

**Figure 87. Inserting Processor**

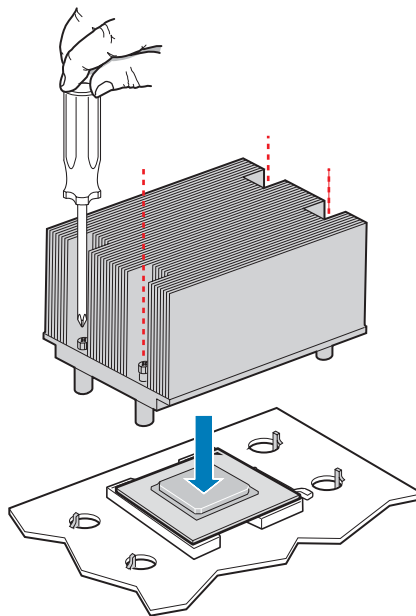
8. Lower the socket lever completely.



TP00765

**Figure 88. Closing Socket Lever**

9. The heatsink has Thermal Interface Material (TIM) located on the bottom of it. Use caution when you unpack the heatsink so that you do not damage the TIM.
10. Set the heatsink over the processor, lining up the four captive screws with the four posts surrounding the processor. Loosely screw in the captive screws on the heatsink corners in a diagonal manner. Do not fully tighten one screw before tightening another. Gradually and equally tighten each captive screw until each is firmly tightened.



TP00774

**Figure 89. Installing the Heatsink**



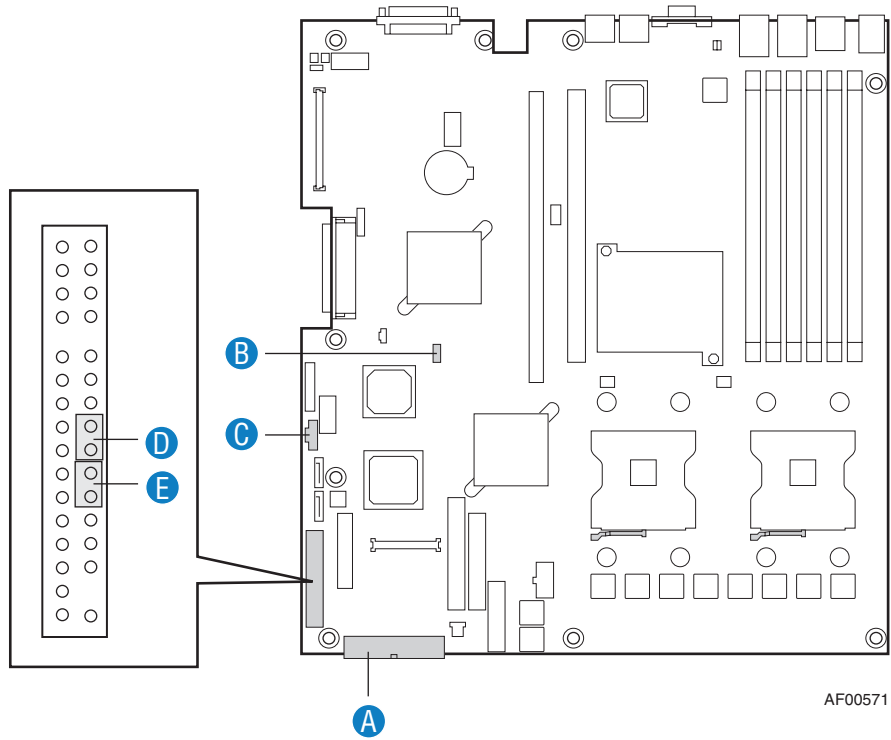
11. Re-install and reconnect any parts you removed or disconnected to reach the processor sockets.
12. Re-install the processor duct. For instructions, see [“Installing the Processor Air Duct” on page 73](#).
13. Install the enclosure cover. For instructions, see [“Installing the Enclosure Cover” on page 16](#).
14. Re-connect all peripheral devices and the AC power cable. Power up the storage system.

## Replacing a Chassis (FXCCHASSIS)

**Caution:** Before performing any maintenance on the system, back up the data. Follow the instructions in the operating system manual for shutting down the system.

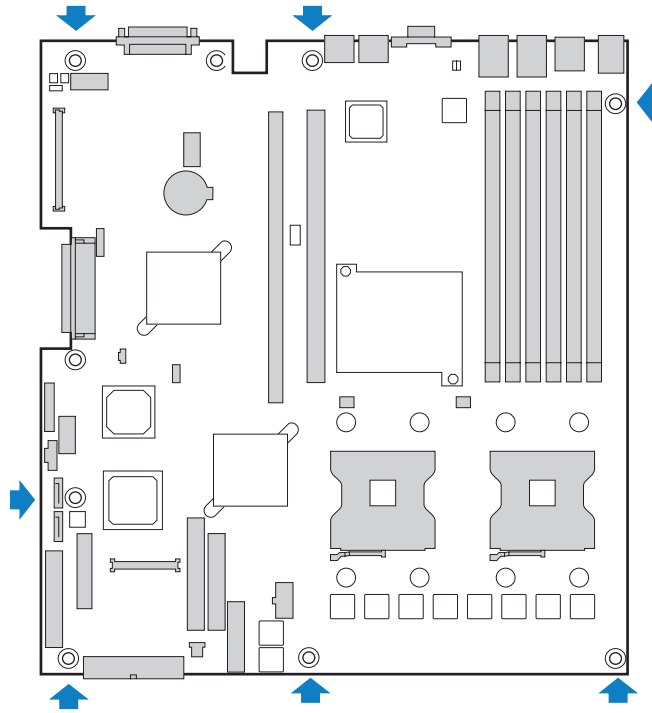
1. Observe all safety and ESD precautions listed in [Appendix D, “Safety Information”](#).
2. Turn off all peripheral devices connected to the storage system. Turn off the storage system.
3. Disconnect the AC power cord(s).
4. Remove the enclosure cover. For instructions, see [“Removing the Enclosure Cover” on page 14](#).
5. Remove the cooling module. For instructions, see [“Removing the Cooling Module” on page 51](#).
6. Remove the processor air duct. For instructions, see [“Removing the Processor Air Duct” on page 72](#).
7. Remove the PCI riser assembly. For instructions, see [“Removing the PCI Riser Assembly” on page 22](#).

8. Disconnect the main power cable from the server board (see letter “A” in the following figure). Disconnect the IPMB cable (see letter “B”). Disconnect the P3 power supply signal cable (see letter “C”). Disconnect the reset (see letter “D”) and power switch (see letter “E”) cables.



**Figure 90. Disconnecting Cables from Server Board**

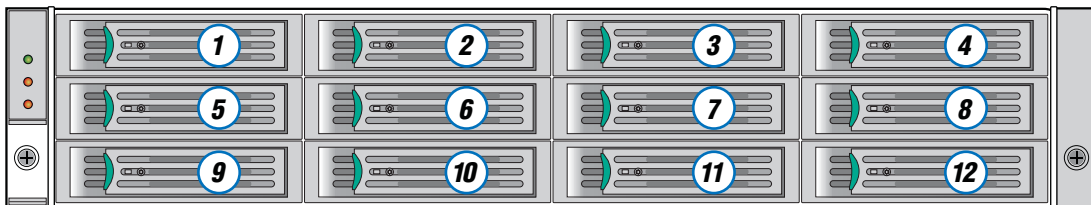
- Remove the seven screws securing the server board to the chassis. Remove the server board.



TP02012

**Figure 91. Installing Server Board in Chassis**

- Ensure that all the drive carriers have been labeled according to the following numbering order.



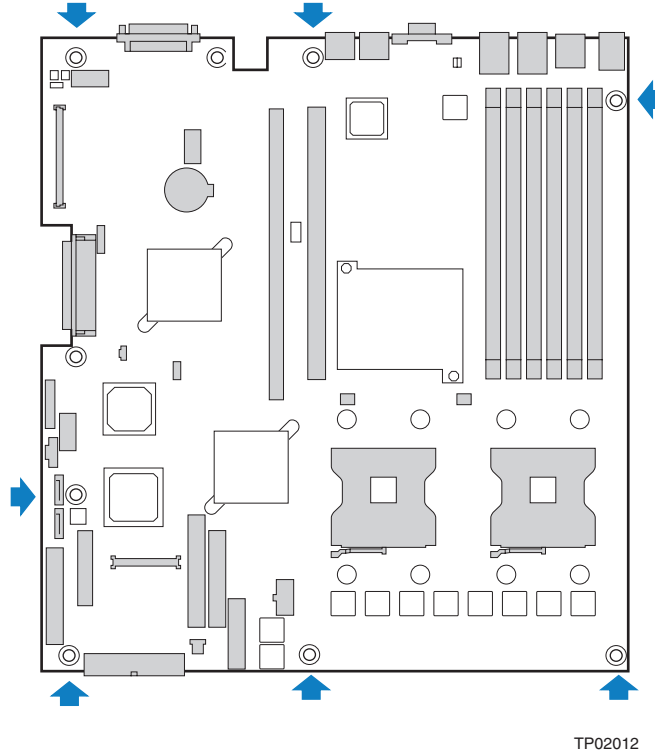
TP01831

**Figure 92. Drive Bay Numbering Order**

- Remove all drive carriers. For instructions, see “Removing a Drive Carrier” on page 62.

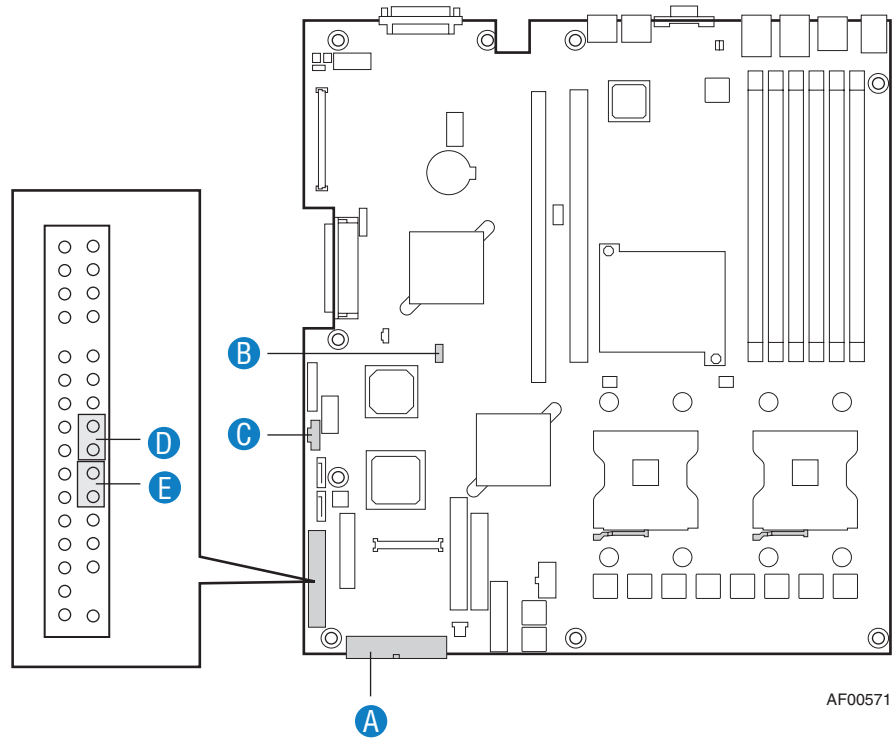
**Note:** The following steps are performed on the replacement chassis.

12. Install the server board by aligning the screw holes in the server board with the standoffs in the new chassis.



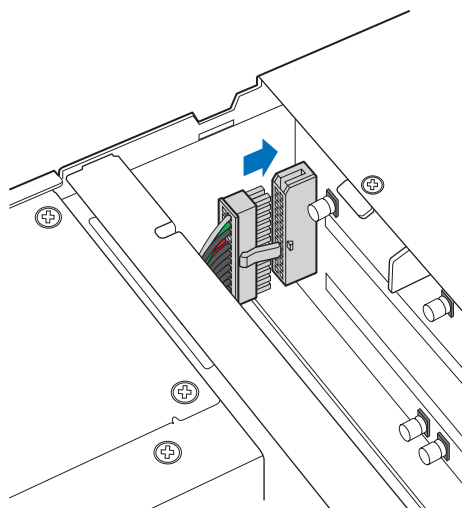
**Figure 93. Installing Server Board in Chassis**

13. Connect the main power cable to the server board (see letter “A” in the following figure). Connect the IPMB cable (see letter “B”). Connect the P3 power supply signal cable (see letter “C”). Connect the reset (see letter “D”) and power switch (see letter “E”) cables.



**Figure 94. Connecting Cables to Server Board**

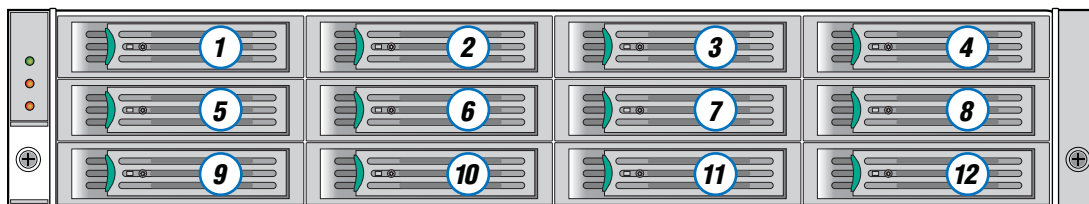
14. Ensure the P4 power supply cable is properly connected to the backplane connector.



TP02036

**Figure 95. Connecting P4 Power Supply Cable to Backplane**

15. Install the PCI riser assembly into the new chassis. For instructions, see “[Installing the PCI Riser Assembly](#)” on page 25.
16. Install the processor air duct over the processor on the server board. For instructions, see “[Installing the Processor Air Duct](#)” on page 73.
17. Install the cooling module into the new chassis. For instructions, see “[Installing the Cooling Module](#)” on page 54.
18. Install the enclosure cover. For instructions, see “[Installing the Enclosure Cover](#)” on page 16.
19. Install all drive carriers into the chassis. For instructions, see “[Installing a Drive Carrier](#)” on page 63. Ensure that all drive carriers are installed in the proper order.



TP01831

**Figure 96. Drive Bay Numbering Order**

20. Re-connect all peripheral devices and the AC power cable. Power up the storage system.

## Replacing the Server Board Battery

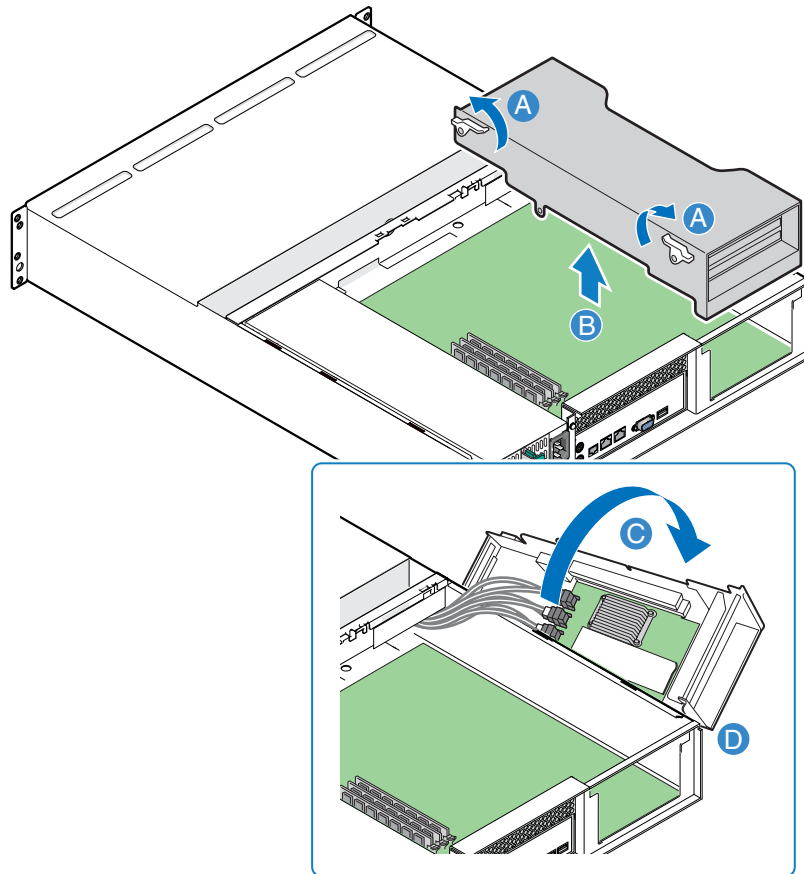
The server board is fitted with a coin cell battery, type CR2032, located under the riser card module.

**Caution:** *Before performing any maintenance on the system, back up the data. Follow the instructions in the operating system manual for shutting down the system.*

**Warning:** *There is a danger of explosion if the battery is replaced by an incorrect type. Dispose of used batteries in accordance with the manufacturer's instructions and National regulations.*

1. Observe all safety and ESD precautions listed in [Appendix D, "Safety Information"](#).
2. Turn off all peripheral devices connected to the storage system. Turn off the storage system.
3. Disconnect the AC power cord(s).
4. Remove the enclosure cover. For instructions, see ["Removing the Enclosure Cover" on page 14](#).
5. Remove the processor air duct. For instructions, see ["Removing the Processor Air Duct" on page 72](#).

6. Unlatch the two levers (see letter “A” in the following figure) on the PCI riser assembly and lift the assembly out of the chassis (see letter “B”). Lay the PCI riser assembly over on its side (see letter “C”). Be sure to support the PCI riser assembly so that the connectors on the PCI riser assembly and components on the RAID controller cards do not rub against the sheet metal of the chassis. Place a support underneath the PCI riser assembly, next to the chassis and workbench, to minimize the stress on the cables (see letter “D”).

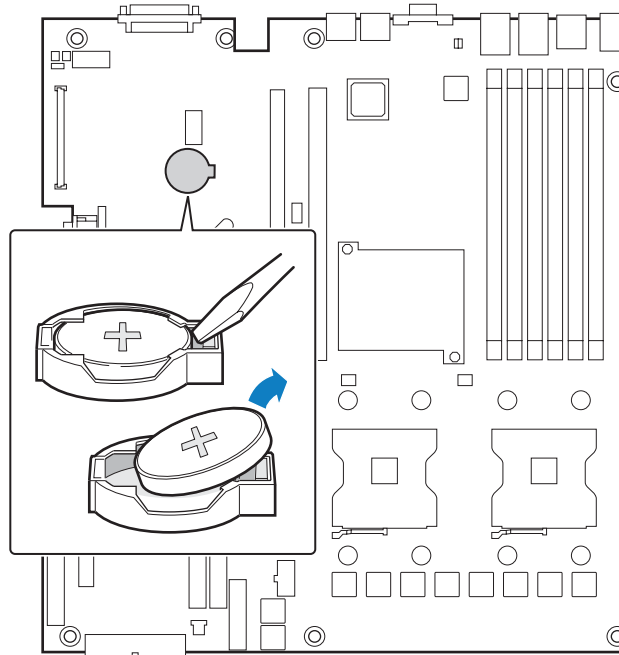


TP00879

**Figure 97. Removing PCI Riser Assembly from Chassis**



7. Locate the battery. With the tip of a small flat-headed screwdriver, or equivalent, insert the tip of the screwdriver under the tab in the plastic retainer. Gently push down on the screwdriver to lift the battery. Remove the battery from its socket.

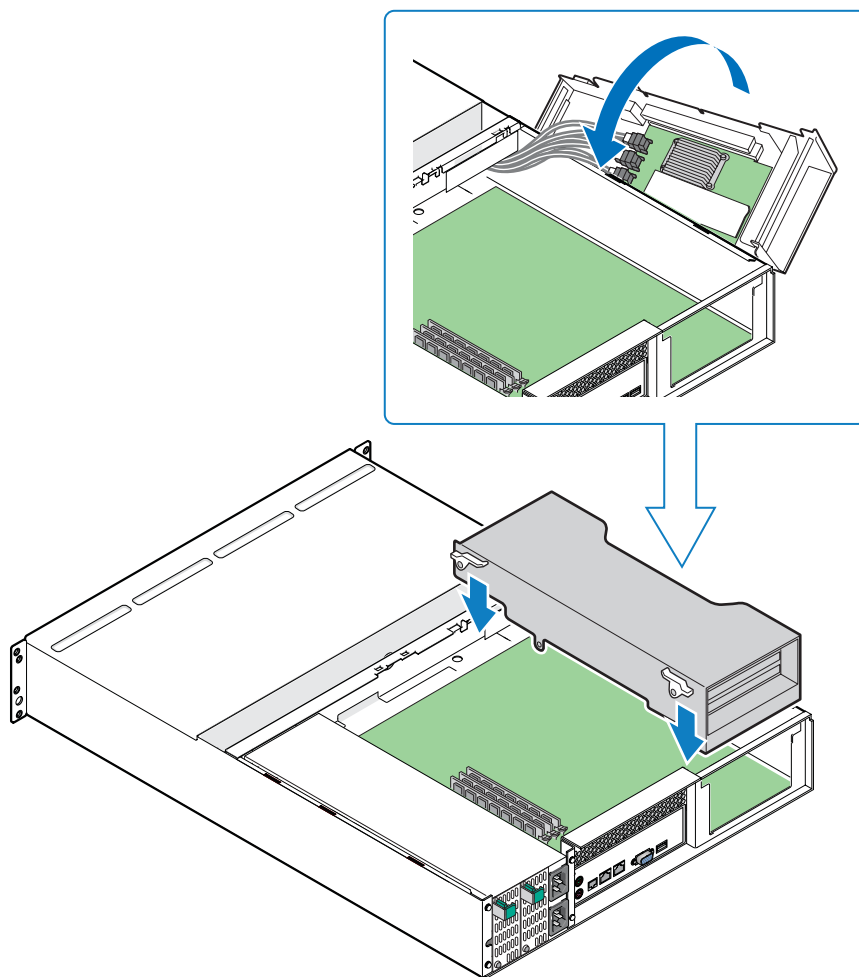


TP00760

**Figure 98. Removing Server Board Battery**

8. Dispose of the battery according to local ordinance.
9. Remove the new lithium battery from its package, and, being careful to observe the correct polarity, insert it in the battery socket.

10. Ensure the SATA cables are connected securely to the RAID controller cards and the backplane. Install the PCI riser assembly by matching the hooks on the back of the PCI riser assembly with the notches on the cross bar and rear of the chassis. Guide the PCI riser assembly home by firmly gripping and sliding the assembly downwards until the riser card mates with the connector on the server board. The latches should lock into position once the PCI riser assembly is seated properly.



TP00876

**Figure 99. Installing PCI Riser Assembly into Chassis**

11. Install the processor air duct over the processor on the server board. For instructions, see [“Installing the Processor Air Duct”](#) on page 73.
12. Install the enclosure cover. For instructions, see [“Installing the Enclosure Cover”](#) on page 16.
13. Re-connect all peripheral devices and the AC power cable. Power up the storage system.

## Removing or Installing Memory

The silkscreen on the server board for the DIMMs displays DIMM1B, DIMM1A, DIMM2B, DIMM2A, DIMM3B, and DIMM3A starting from the edge of the server board. DIMM3A is the socket closest to the processor socket.

**Note:** The DIMMs that are to be installed in the server board **MUST** match the DIMM slots present on the server board. DDR DIMMs will not physically fit into a server board designed to support DDR2 DIMMs. DDR2 DIMMs will not physically fit into a server board designed to support DDR DIMMs.

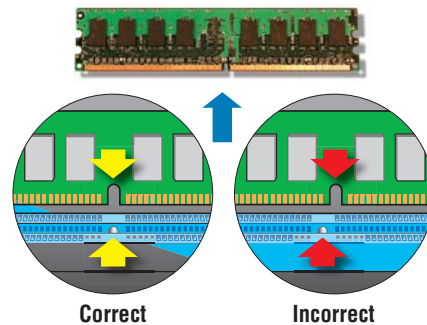


Figure 100. DIMM Identification

## Memory Requirements

The Intel® Server Board SE7520JR2 provides six DIMM sockets across two channels: Channel A and Channel B. Channel A consists of DIMM sockets 1A, 2A, and 3A. Channel B consists of DIMM sockets 1B, 2B, and 3B. Refer to the *Tested Memory List* at <http://www.intel.com/support/motherboards/server/ssr212cc/> for the current list of supported memory.

If six DIMMs are installed, the following maximum capacity is possible:

- DDR2-400: Maximum capacity of 16 GB.

A minimum of one 256-MB DIMM is required in DIMM socket 1A or 1B. This uses single-channel interleave. However, for dual-channel interleave providing optimum performance, a minimum of two DIMMs should be installed in DIMM sockets 1A and 1B. Except for the option of installing a single DIMM in sockets 1A or 1B, DIMMs must be installed in pairs and populated as follows:

- DIMM1A and DIMM1B: Populate these two sockets first
- DIMM2A and DIMM2B: Populate these sockets in addition to DIMM1A and DIMM2A if four DIMMs are to be used
- DIMM3A and DIMM3B: Populate these sockets after DIMM1A, DIMM1B, DIMM2A, and DIMM2B have been populated

DIMMs must meet the following requirements:

- DDR2-400 ECC, registered DDR DIMM modules
- Use only DIMMs that comply with the DDR specifications
- Use only DIMMs with a DIMM organization of x72 ECC
- Use only 240-pin DIMMs
- Use only DIMMs with the capacities outlined in the following table.

**Table 4. DIMM Module Memory Capacity Support**

SDRAM Parts, SDRAM Technology	256 MB	512 MB	1 GB
x8, single row	256 MB	512 MB	1 GB
x8, double row	512 MB	1 GB	2 GB
x4, single row	512 MB	1 GB	2 GB
x4, stacked, double row	1 GB	2 GB	4 GB

**Note:** When using either dual-rank (double-row) DDR2-400 DIMM technologies, a maximum of four loads per memory channel is supported. When all DIMMs used in the system match either of these technologies, a maximum of four DIMMs can be populated. Refer to the Intel® Server Board SE7520JR2 Technical Product Specification for additional information regarding the memory sub-system.

## Memory Sparing and Mirroring

The Intel® E7520 chipset includes hardware that supports memory mirroring and memory on-line sparing. Both memory mirroring and memory on-line sparing provide a way to prevent data loss in case of a DIMM failure.

With memory mirroring, the system maintains two copies of all data in the memory sub-system. If a DIMM fails, the data is not lost because the second copy of the data is available from the mirrored DIMM in the opposite channel. The system will not fail due to memory error unless both the primary and the mirrored copy of the data become corrupt at the same time.

In a mirrored system, the maximum usable memory is one-half of the installed memory, with a minimum of four DIMMs installed. Since the data is duplicated across DIMMs, it means that up to one-half of the installed DIMMs are actively in use at any one time. The remaining DIMMs are used for mirroring.

Two methods for memory mirroring are available:

- Four identical DIMMs are used in DIMM sockets 1A, 1B, 2A, and 2B
  - If the DIMM in socket 1A fails, the DIMM in socket 2B takes over.
  - If the DIMM in socket 1B fails, the DIMM in socket 2A takes over.
- Four DIMMs are used with identical single-ranked DIMMs in banks 2 and 3. DIMMs in sockets 1A and 1B must be dual-ranked and identical.

- If the DIMM in socket 1A fails, the DIMM in socket 1B takes over.
- If the DIMM in socket 2A fails, the DIMM in socket 3B takes over.
- If the DIMM in socket 2B fails, the DIMM in socket 3A takes over.

For memory on-line sparing, one DIMM per channel is used as the memory spare. The spare DIMM is not available for use, but is kept in reserve. If a DIMM begins to fail, the content of the failing DIMM is copied to the spare DIMM in that channel. When all of the data is copied to the spare DIMM, the primary DIMM is removed from service and the spare DIMM takes its place.

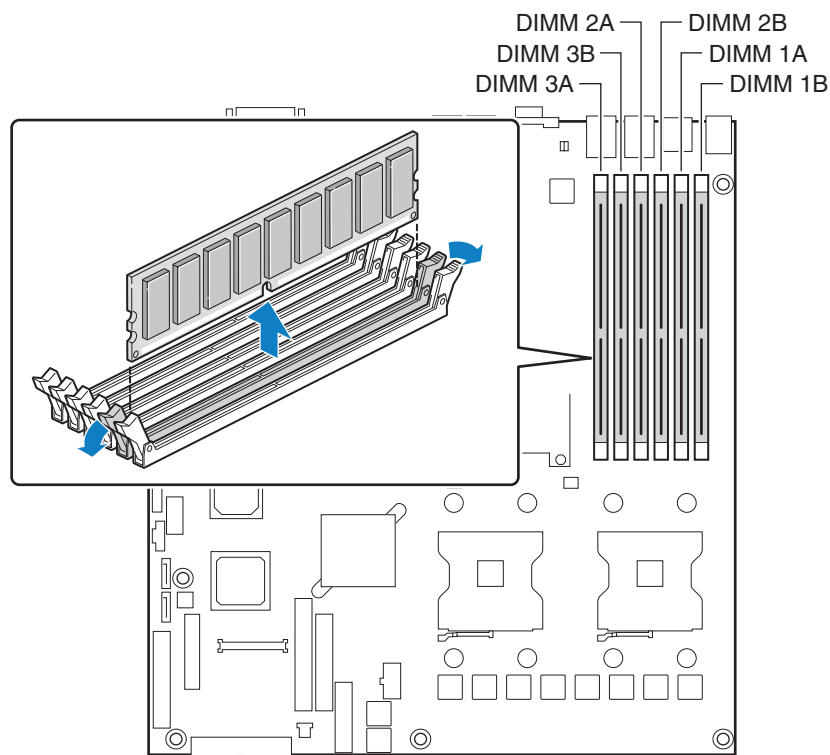
When memory on-line sparing is used, the spare DIMMs must be equal to or larger than the largest in-service DIMM in that channel.

## Removing DIMMs

**Caution:** *Before performing any maintenance on the system, back up the data. Follow the instructions in the operating system manual for shutting down the system.*

1. Observe all safety and ESD precautions listed in [Appendix D, “Safety Information”](#).
2. Turn off all peripheral devices connected to the storage system. Turn off the storage system.
3. Disconnect the AC power cord(s).
4. Remove the enclosure cover. For instructions, see [“Removing the Enclosure Cover” on page 14](#).
5. Remove the processor air duct. For instructions, see [“Removing the Processor Air Duct” on page 72](#).

6. Gently spread the retaining clips at each end of the DIMM socket. Holding the DIMM by its edges, lift it from the DIMM socket and store in an anti-static package.



TP01778

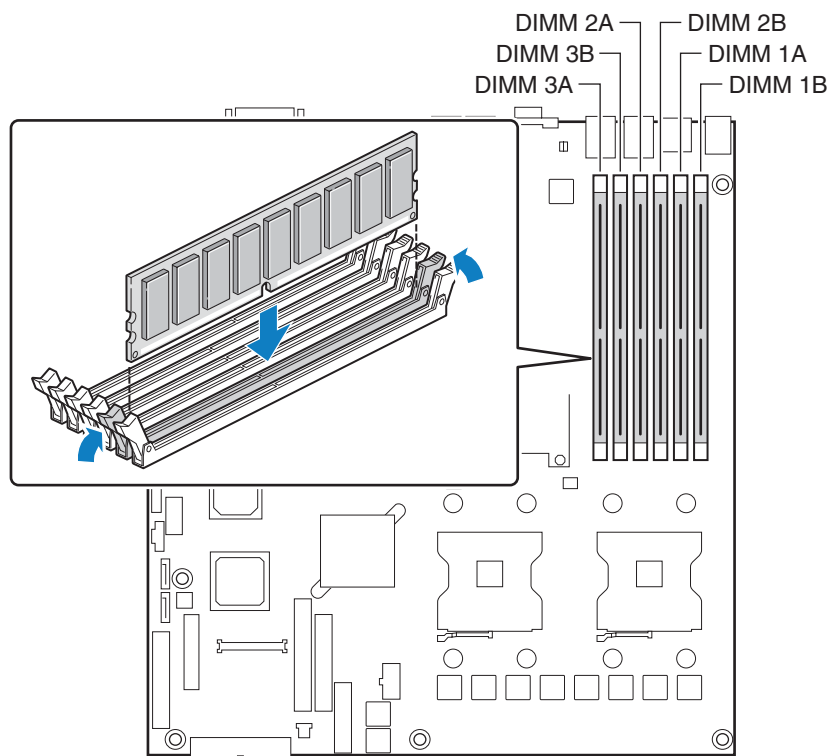
**Figure 101. Removing Memory**

7. If removing DIMMs are part of another procedure, continue with that procedure.
8. If replacing the DIMM, see [“Installing DIMMs” on page 93](#) for instructions.
9. Reinstall the processor duct. For instructions, see [“Installing the Processor Air Duct” on page 73](#).
10. Install the enclosure cover. For instructions, see [“Installing the Enclosure Cover” on page 16](#).
11. Re-connect all peripheral devices and the AC power cable. Power up the storage system.

## Installing DIMMs

**Caution:** Before performing any maintenance on the system, back up the data. Follow the instructions in the operating system manual for shutting down the system.

1. Observe all safety and ESD precautions listed in [Appendix D, “Safety Information”](#).
2. Turn off all peripheral devices connected to the storage system. Turn off the storage system.
3. Disconnect the AC power cord(s).
4. Remove the enclosure cover. For instructions, see [“Removing the Enclosure Cover” on page 14](#).
5. Remove the processor air duct. For instructions, see [“Removing the Processor Air Duct” on page 72](#).
6. Locate the DIMM sockets. Make sure the clips at either end of the DIMM socket(s) are pushed outward to the open position. Holding the DIMM by its edges, remove it from its anti-static package.
7. Position the DIMM above the socket. Align the notch on the bottom edge of the DIMM with the key in the DIMM socket. Insert the bottom edge of the DIMM into the socket. Once the DIMM is inserted, push down on the top edge of the DIMM until the retaining clips snap into place. Make sure the clips are latched firmly in place.



TP00761

**Figure 102. Installing Memory**

8. Reinstall the processor duct. For instructions, see “Installing the Processor Air Duct” on page 73.
9. Install the enclosure cover. For instructions, see “Installing the Enclosure Cover” on page 16.
10. Re-connect all peripheral devices and the AC power cable. Power up the storage system.

## Removing or Installing the Intel® Management Module Professional (IMM Pro) Module

### Removing the IMM Pro Module

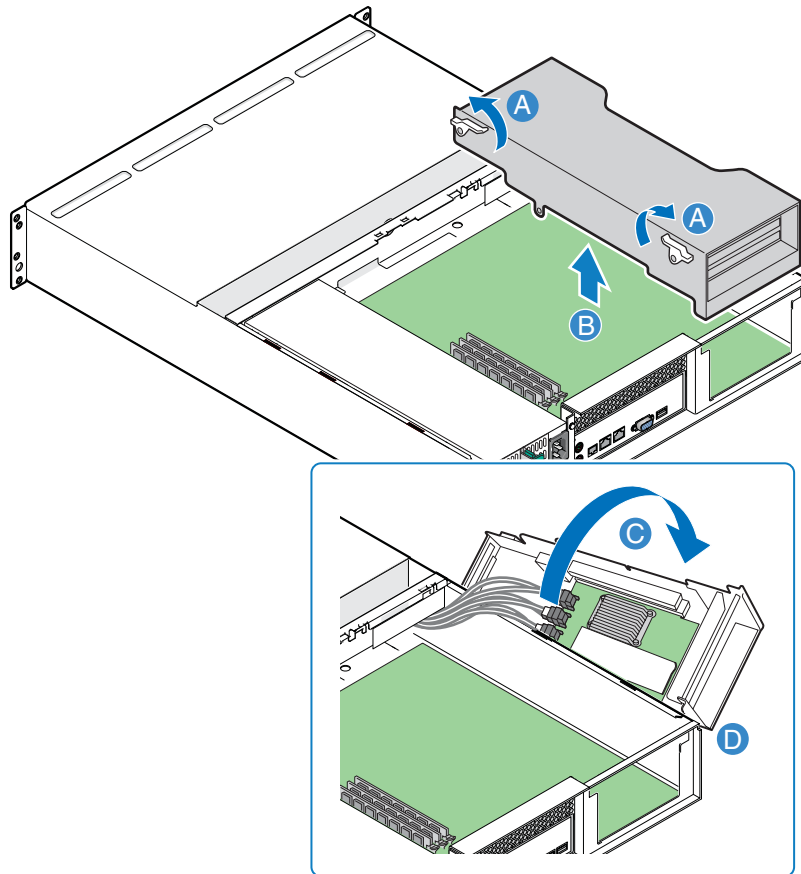
**Caution:** Before performing any maintenance on the system, back up the data. Follow the instructions in the operating system manual for shutting down the system.

**Caution:** Before installing an IMM Pro module, ensure that the module has the correct firmware version installed. This may require setting up the module in an external system (with a CD-ROM or floppy drive) and updating with the appropriate firmware version. Refer to the Intel® Storage System SSR212CC Tested Hardware and Operating System List for the tested firmware version. Refer to the support site at <http://www.intel.com/support/motherboards/server/ism> for the appropriate firmware and documentation to download.

1. Observe all safety and ESD precautions listed in [Appendix D, “Safety Information”](#).
2. Turn off all peripheral devices connected to the storage system. Turn off the storage system.
3. Disconnect the AC power cord(s).
4. Remove the enclosure cover. For instructions, see “Removing the Enclosure Cover” on page 14.



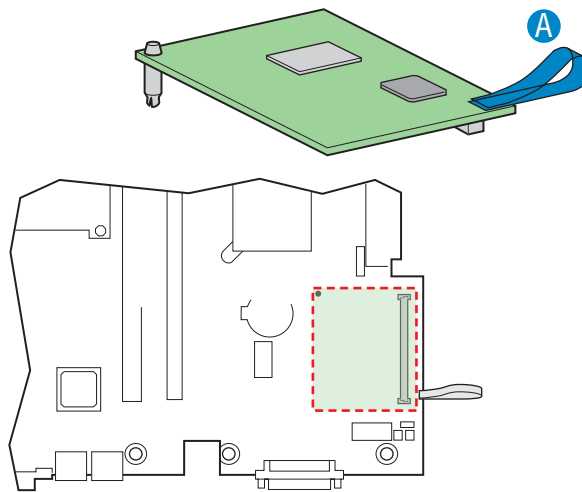
5. Unlatch the two levers (see letter “A” in the following figure) on the PCI riser assembly and lift the assembly out of the chassis (see letter “B”). Lay the PCI riser assembly over on its side (see letter “C”). Be sure to support the PCI riser assembly so that the connectors on the PCI riser assembly and components on the RAID controller cards do not rub against the sheet metal of the chassis. Place a support underneath the PCI riser assembly, next to the chassis and workbench, to minimize the stress on the cables (see letter “D”).



TP00879

**Figure 103. Removing PCI Riser Assembly from Chassis**

6. Pinch the end of the stand-off and slightly raise the IMM Pro module to disengage the stand-off from the server board. To avoid damage to the connector, do not lift the edge of the IMM Pro module that is farthest from the connector (near the stand-off). Grasp the blue plastic strap (see letter “A” in the following figure) and gently pull up to disengage the connector closest to the strap. Using your fingers, grasp the IMM Pro module near the end of the connector and gently rock the module back and forth until the connector is completely disengaged.

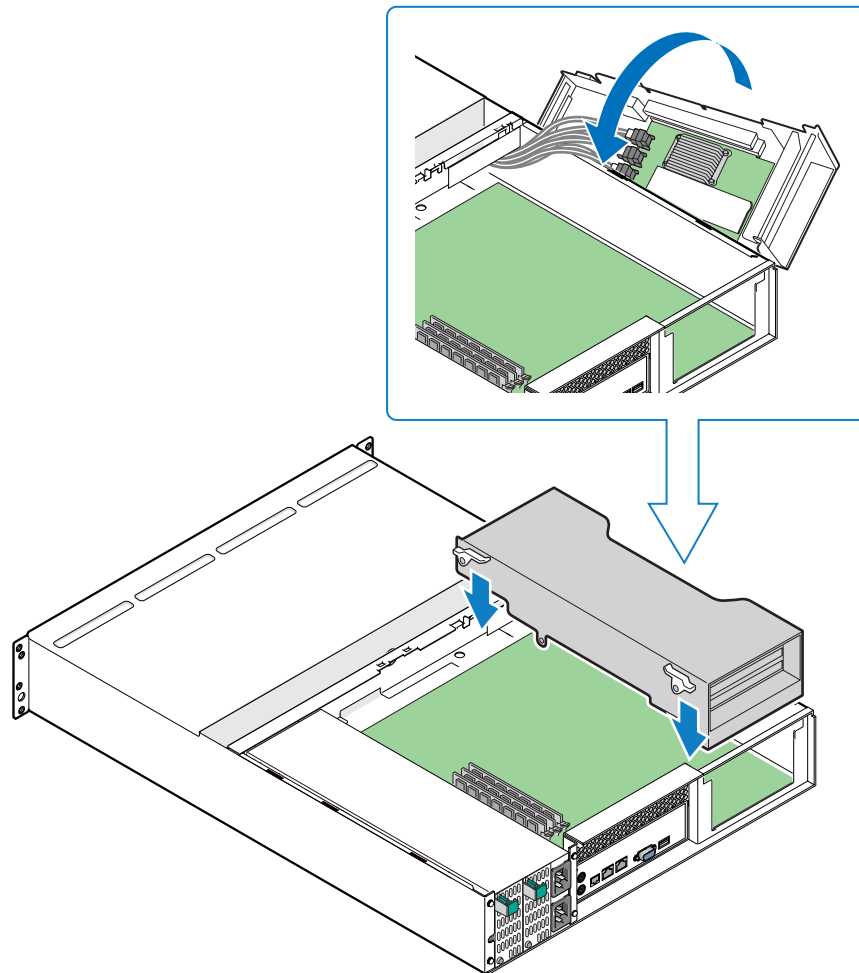


TP02011

**Figure 104. Removing IMM Pro Module from Server Board**

7. If removing the IMM Pro module as part of another procedure, continue with that procedure.

8. Ensure the SATA cables are connected securely to the RAID controller cards and the backplane. Install the PCI riser assembly by matching the hooks on the back of the PCI riser assembly with the notches on the cross bar and rear of the chassis. Guide the PCI riser assembly home by firmly gripping and sliding the assembly downwards until the riser card mates with the connector on the server board. The latches should lock into position once the PCI riser assembly is seated properly.



TP00876

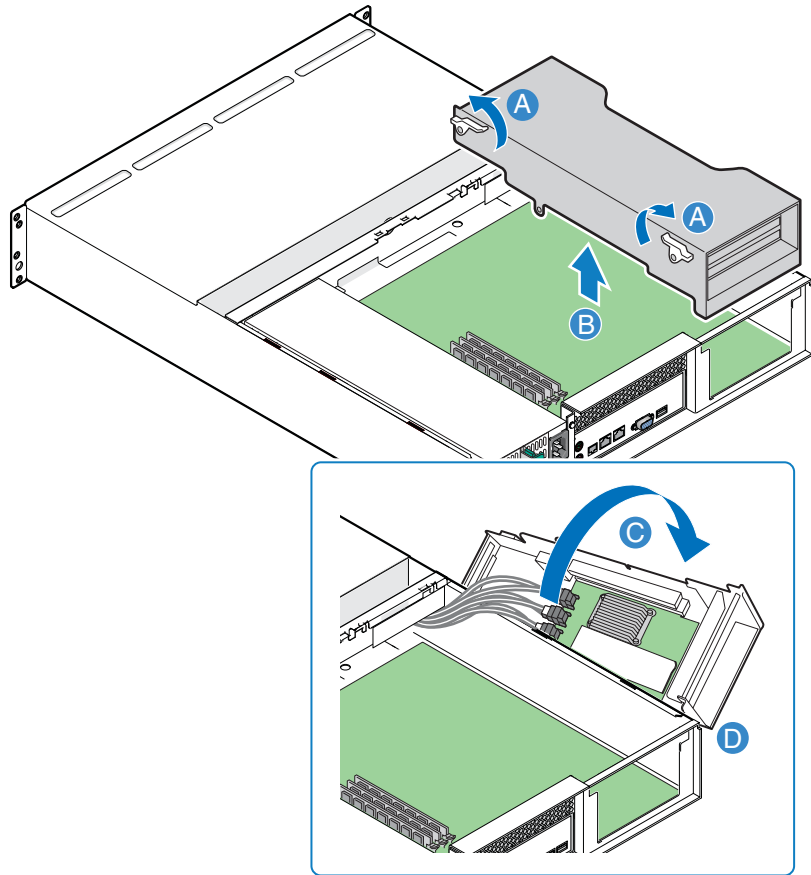
**Figure 105. Installing PCI Riser Assembly into Chassis**

9. Install the enclosure cover. For instructions, see [“Installing the Enclosure Cover”](#) on page 16.
10. Re-connect all peripheral devices and the AC power cable. Power up the storage system.

## Installing the IMM Pro Module

**Caution:** Before performing any maintenance on the system, back up the data. Follow the instructions in the operating system manual for shutting down the system and programming the IMM password. Refer to the support site at <http://www.intel.com/support/motherboards/server/ssr212cc> for the appropriate firmware to use.

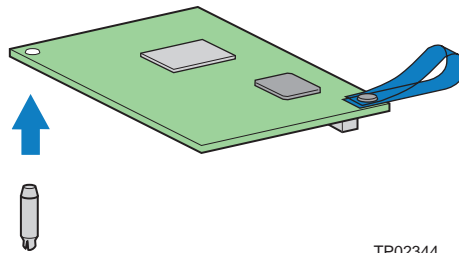
1. Observe all safety and ESD precautions listed in [Appendix D, “Safety Information”](#).
2. Turn off all peripheral devices connected to the storage system. Turn off the storage system.
3. Disconnect the AC power cord(s).
4. Remove the enclosure cover. For instructions, see [“Removing the Enclosure Cover” on page 14](#).
5. Unlatch the two levers (see letter “A” in the following figure) on the PCI riser assembly and lift the assembly out of the chassis (see letter “B”). Lay the PCI riser assembly over on its side (see letter “C”). Be sure to support the PCI riser assembly so that the connectors on the PCI riser assembly and components on the RAID controller cards do not rub against the sheet metal of the chassis. Place a support underneath the PCI riser assembly, next to the chassis and workbench, to minimize the stress on the cables (see letter “D”).



TP00879

**Figure 106. Removing PCI Riser Assembly from Chassis**

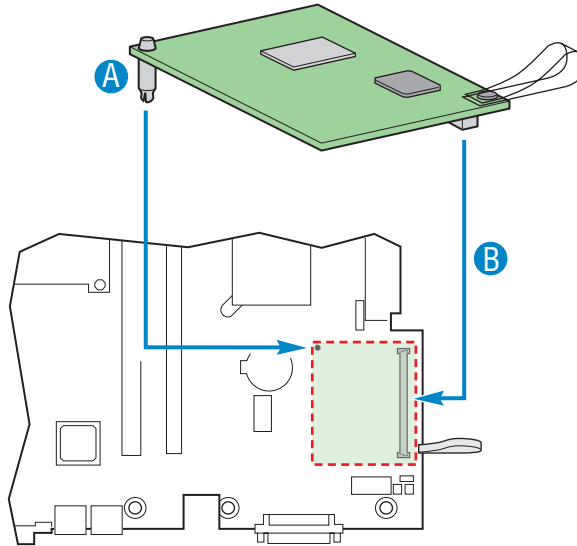
6. If not already present, attach the nylon stand-off to the IMM Pro module.



TP02344

**Figure 107. Securing IMM Pro Module Stand-off to Server Board**

7. Align the standoff and connector on the IMM Pro module with the corresponding hole on the server board (see letter “A” in the following figure). Press down on the IMM Pro module until the module seats itself in the connector (see letter “B”) on the server board.

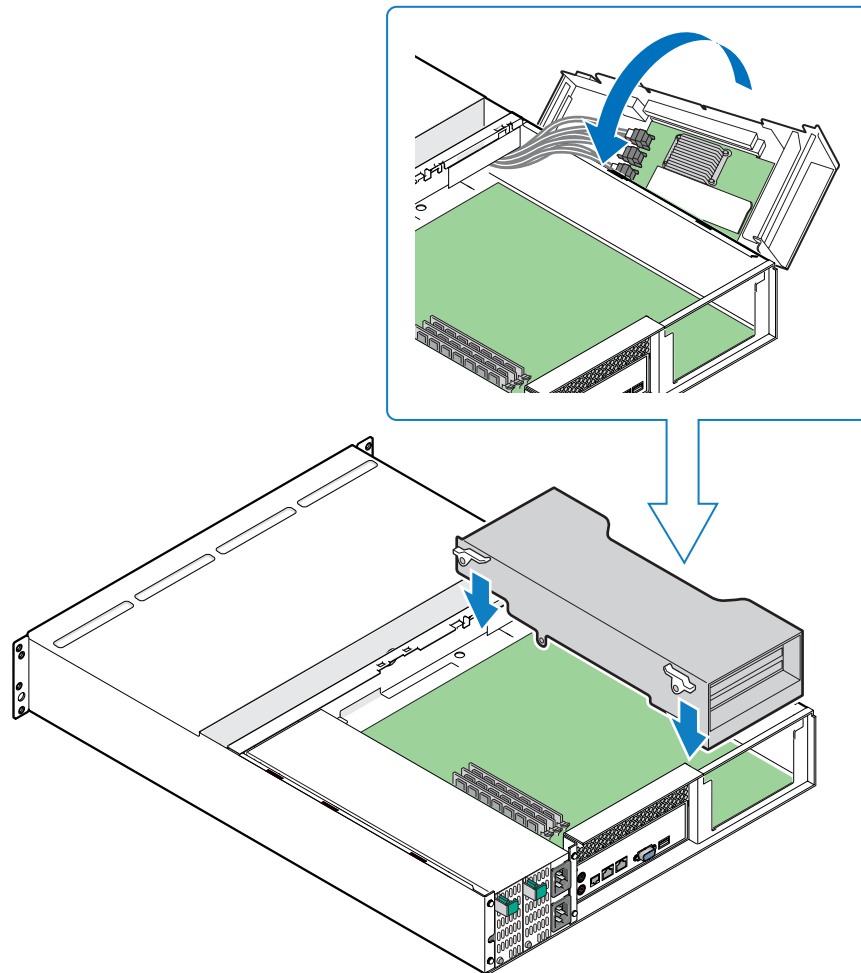


TP01867

**Figure 108. Installing IMM Pro Module to Server Board**

8. If installing the IMM Pro module as part of another procedure, continue with that procedure.

9. Ensure the SATA cables are connected securely to the RAID controller cards and the backplane. Install the PCI riser assembly by matching the hooks on the back of the PCI riser assembly with the notches on the cross bar and rear of the chassis. Guide the PCI riser assembly home by firmly gripping and sliding the assembly downwards until the riser card mates with the connector on the server board. The latches should lock into position once the PCI riser assembly is seated properly.



TP00876

**Figure 109. Installing PCI Riser Assembly into Chassis**

10. Install the enclosure cover. For instructions, see [“Installing the Enclosure Cover”](#) on page 16.
11. Re-connect all peripheral devices and the AC power cable. Power up the storage system.





# 3 Operation

---

## Before You Begin

Before powering up the enclosure please ensure that all the modules are firmly seated in their correct bays.

## Power On

**Caution:** Do not operate the subsystem until the ambient temperature is within the specified operating range. If the drives have been recently installed, ensure they have had sufficient time to acclimatize before operating them.

**Note:** Please refer to “[Front Panel LEDs](#)” on page 104 for details of the Front Panel LEDs and related fault conditions.

Perform the following to Power On the storage system:

1. Apply AC mains power to the storage system. Press the Power button on the back of the system.
2. All LEDs on the Front Panel should be lit (green) when the storage system power is activated (and the disk drive motors should start). The system may take up to 15 minutes to boot up.

**Important:** If mains power is lost for any reason, on restoration of power, the storage system will re-start automatically.

## Power Supply Module LED

The power supply module provides a single external bi-color LED to indicate the status of the power supply. When AC power is applied to the power supply module and standby voltage is available, the LED will blink green. The LED will be solid on green to indicate that all power outputs are available. The LED will be solid on amber to indicate that the power supply has failed, there has been a shut down due to an over current or over temperature condition, or there has been a predictive failure. Refer to the following table for conditions of the power supply module LED.

**Table 5. Power Supply Module LED Indicators**

Power Supply Condition	Power Supply LED
No AC power to all power supply modules	OFF
No AC power to this power supply module only	Amber

**Table 5. Power Supply Module LED Indicators**

Power Supply Condition	Power Supply LED
AC power present/only stand-by outputs on	Blinking green
Power supply direct current (DC) outputs ON and OK	Green
Power supply failure (includes over current or over temperature)	Amber
Voltage regulator module (VRM) failure (cage related)	Blinking green
240-VA limit (cage related)	Blinking green
Current limit	Amber

## Front Panel LEDs

The Front Panel LED fault and status conditions are defined in the following table.

Refer to “[Troubleshooting and Problem Solving](#)” on page 107 for details on any fault conditions.

**Table 6. Front Panel LED Indicators**

LED	Definition
<b>Power</b>	Continuous green light indicates the system has power applied to it. No light indicates the system does not have power applied to it (other than 5-V standby power).
<b>Fault</b>	Continuous amber light indicates a fault is present. <b>NOTE:</b> The fault LED may temporarily stay lit when booting up the system.
<b>ID</b>	The blue system identification LED is used to help identify a system for servicing. This is especially useful when the system is installed in a high-density rack or cabinet that is populated with several similar systems.

## Rear Panel Buttons

**Table 7. Rear Panel Button Functions**

Button	Definition
Power	Toggles the system power on/off.
Reset	Resets the system

## Starting the Drives

Unless otherwise selected during installation, all drives in the enclosure should automatically start their motors. If this does not occur then one of the following conditions may exist:

- There may be a power problem (an alarm and power fault indication would normally be active).
- If there is only one power supply module present, the drive motors will spin up in a delayed sequence.

## Disk Drives LEDs

Each drive carrier incorporates a green Drive Status LED and an amber Drive Fault LED.

LED	Definition
Drive Status LED	Flashes green as drive operates
Drive Fault LED	Continuous amber light indicates a failure condition

## Power Down

To power down the storage system:

- Refer to the documentation that came with your operating system for instructions on how to shut down the system.
- In the event of a system failure or hang condition that prevents you from powering down the system via the Intel® Storage System Console, do the following:

Hold down the Power button for approximately 3 seconds

**OR**

Remove AC mains at the power source.

*Operation*

# 4 Troubleshooting and Problem Solving

---

## Overview

The Intel® Storage System SSR212CC enclosure includes an enclosure services processor and associated monitoring and control logic to enable it to diagnose problems within the enclosure's power, cooling and drive systems.

The sensors for power and cooling conditions are housed within the power supply and cooling modules. There is independent monitoring for each unit.

## Initial Start-up Problems

### Faulty Cords

First check that you have wired up the subsystem correctly. Call your supplier for a replacement cord if:

- Cords are missing or damaged
- Plugs are incorrect
- Cords are too short.

### Computer Doesn't Recognize the Intel® Storage System SSR212CC Subsystem

1. Check that the interface cables from the enclosure to the host computer are fitted correctly.
2. Check that the Drive Status LEDs on all installed drive carrier modules are illuminated (green and blinking with activity). Note that the Drive Status LEDs will not be lit during drive spin-up.
3. Check that all drive carrier modules have been correctly installed.

## LEDs

Green LEDs are always used for good or positive indication; flashing Green/Amber are used if non-critical conditions exist. Amber LEDs indicate there is a critical fault present within the module.

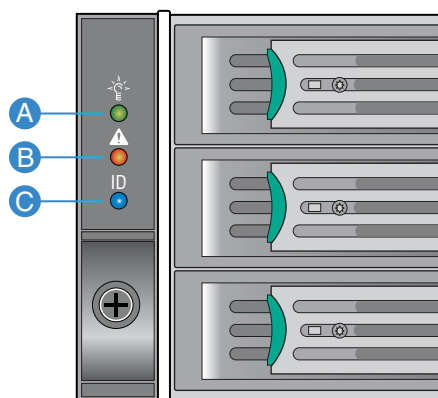
## Power Supply Units

Under Normal conditions, the Power On LEDs will be illuminated constant GREEN.

## Front Panel

The Front Panel displays the aggregated status of all the modules. The Front Panel LEDs are defined in [Table 8](#).

**Note:** *The Front Panel is supplied as an integral part of the enclosure core product and is not user replaceable.*



TP01833

**Figure 110. Front Panel LEDs**

**Table 8. Front Panel LED States**

LED	Color	Normal Status	Fault Status
Power	Green	On	On
Fault	Amber	Off	On
ID	Blue	N/A	N/A

## Troubleshooting

The following sections describe common problems, with possible solutions, which can occur with your Intel® Storage System SSR212CC. Refer to the *Intel® Server Board SE7520JR2 User Guide* for additional troubleshooting information on the server board.

For details on how to remove and replace a module, see [Chapter 2, “Hardware Installations and Upgrades”](#).

## Power Supply Module Faults

Symptom	Cause	Action
1. Front Panel FAULT LED amber	1. Any power fault	1. Check that the AC mains connection to power supply/unit is live.

## Thermal Control

The Intel® Storage System SSR212CC enclosure uses extensive thermal monitoring and takes a number of actions to ensure component temperatures are kept low and also to minimize acoustic noise. Airflow is from front to rear of the enclosure.

Symptom	Cause	Action
<p>If the ambient air is cool (below 25 °C) and the fans are observed to increase in speed then some restriction on airflow may be causing additional internal temperature rise.</p> <p><b>NOTE:</b> This is not a fault condition.</p>	<p>The first stage in the thermal control process is for the fans to automatically increase in speed when a thermal threshold is reached. This may be caused by higher ambient temperatures in the local environment and may be perfectly normal.</p> <p><b>NOTE:</b> This threshold changes according to the number of drives and power supplies fitted.</p>	<ol style="list-style-type: none"> <li>1. Check the installation for any airflow restrictions at either the front or rear of the enclosure. A minimum gap of 25 mm at the front and 50 mm at the rear is recommended.</li> <li>2. Check for restrictions due to dust build-up; clean as appropriate.</li> <li>3. Check for excessive re-circulation of heated air from rear to the front, use in a fully enclosed rack installation is not recommended.</li> <li>4. Check that all blank modules are in place.</li> <li>5. Reduce the ambient temperature.</li> </ol>

## Thermal Alarm

Symptom	Cause	Action
<ol style="list-style-type: none"> <li>1. Front Panel fault LED amber.</li> <li>2. An amber LED on one or more power supply/cooling modules.</li> <li>3. Air temperature exiting power supply unit above 55°C.</li> </ol>	<p>If the internal temperature measured in the airflow through the enclosure exceeds a pre-set threshold, a thermal alarm will sound.</p>	<ol style="list-style-type: none"> <li>1. Check that local ambient environment temperature is below the upper 35°C specification.</li> <li>2. Check the installation for any airflow restrictions at either the front or rear of the enclosure. A minimum gap of 25 mm at the front and 50 mm at the rear is recommended.</li> <li>3. Check for restrictions due to dust build-up; clean as appropriate.</li> <li>4. Check for excessive re-circulation of heated air from rear to the front, use in a fully enclosed rack installation is not recommended.</li> <li>5. If possible shutdown the enclosure and investigate the problem before continuing.</li> </ol>

## Thermal Shutdown

**Important:** *An enclosure will shut down when a critical temperature threshold is exceeded in order to prevent permanent damage to the disk drives.*



## Drive Carrier Module Faults

Disk drive status is monitored by an amber LED mounted on the front of each drive carrier module, under electro static interference (ESI) processor control. The LED conditions are defined in the following table.

**Table 9. Drive Fault LED Functions**

State	Amber LED
No drive fitted	Off
Drive Fault bit set	Continuous

**NOTE:** The Drive Status LED may be off for a length of time during power up.

## Blank Drive Carriers

**Important:** *Blank drive carriers must be fitted in all unused drive bays to maintain a balanced airflow.*

## Dealing with Hardware Faults

Ensure that you have obtained a replacement module of the same type *before* removing any faulty module.

**Warning:** *If the Intel® Storage System SSR212CC sub-system is powered up and you remove any module, replace it immediately. If the subsystem is used with modules or module blanks missing for more than a few minutes, the storage system can overheat, causing power failure and data loss. Such use will invalidate the warranty.*

- Replace a faulty drive with a drive of the same type and equal or greater capacity.
- All drive bays must be fitted with a drive carrier or a blank drive carrier in order to maintain a balanced airflow.
- All power supply module(s), electronics modules and/or blank plates must be in place for the air to flow correctly throughout the storage system.



# 5 Technical Specifications

---

## Dimensions

<b>Rack Enclosure</b>	<b>Inches</b>	<b>Millimeters</b>
Height	3.41	86.7
Width across mounting flange	19.01	483
Width across body of enclosure	17.6	447
Depth from flange to rear of enclosure body	23.7	602
Depth from flange to maximum extremity of enclosure (rear hold down)	24.8	631
Depth from flange to furthest extremity at front of unit	0.78	20

## Weight

<b>Maximum Configuration</b>	27.5 kg (61lb)
<b>Enclosure without drives installed</b>	16 kg (35.2 lb)

## AC Power Module (1 or 2 500-W Power Supply Units)

<b>Voltage Range</b>	100 - 240 VAC rated
<b>Voltage Range Selection</b>	Full Range power supply unit
<b>Frequency</b>	50/60 Hz
<b>Inrush Current</b>	50A @ 260VAC
<b>Power Factor Corrections</b>	95% @ 110V full load
<b>Harmonics</b>	Meets EN61000-3-2
<b>Output Rails</b>	6
<b>Dimensions</b>	84 mm high x 101 mm wide x 300 mm long

## Power Supply Safety and EMC Compliance

<b>Safety Compliance</b>	UL 60950
	IEC 60950
	EN 60950
<b>EMC Compliance</b>	CFR47 Part 15B Class A
	EN55022
	EN55024

## Power Cord

**Important:** *The plug and the complete power cord assembly must meet the standards appropriate to the country, and must have safety approvals acceptable in that country.*

### United States

Must be NRTL Listed (National Recognized Test Laboratory, e.g., UL)

<b>Cord type</b>	SV or SVT, 18 AWG minimum, 3 conductor, 4.5 M max length.
<b>Plug</b>	NEMA 5-15P grounding-type attachment plug rated 120V 10A <i>or</i> IEC 320 C14, 250V, 10A.
<b>Socket</b>	IEC 320, C-13, 250V, 10A.

### Europe and Others

General requirements:

<b>Cord type</b>	Harmonized, H05-VVF-3G1.0
<b>Socket</b>	IEC 320, C-13, 250V, 10A.

## Cooling Module

<b>Fans</b>	Quantity: 8
	Three dual-rotor high-speed axial; two single-rotor high-speed axial
	Dimensions: 40mm x 50mm x 38mm
<b>Module</b>	PWM Speed Control
	Single hot pluggable connector to backplane
	Individual tachometer outputs for each fan
	Operated from resettable fused 12V from supply rail

## Environment

	Temperature Range	Relative Humidity	Max. Wet Bulb
<b>Operational</b>	5°C to 35°C	20% to 80% non-condensing	23°C
<b>Non-Operational</b>	1°C to +50°C	8% to 80% non-condensing	27°C
<b>Storage</b>	1°C to +60°C	5% to 80% non-condensing	29°C
<b>Shipping</b>	-40°C to +60°C	5% to 100% non-precipitating	29°C

<b>Airflow</b>	System must be operated with low-pressure rear exhaust installation (Back pressure created by rack doors and obstacles not to exceed 5 pascals [0.5-mm water gauge])
<b>Altitude, Operational</b>	0 to 2133 m (0 to 7,000 ft)
<b>Altitude, Non-operational</b>	-305 to 12,192 m (-1000 to 40,000 ft)
<b>Shock, Operational</b>	Vertical axis 5g peak 1/2 sine, 10ms
<b>Shock, Non-operational</b>	20g 10ms 1/2 sine ( <i>test with drives</i> ) 30g 10ms 1/2 sine ( <i>test without drives</i> )
<b>Vibration, Operational</b>	0.2grms 5-500 Hz Random

<b>Vibration, Non-operational</b>	0.8grms 2-200 Hz Random ( <i>test with drives</i> ) 1.04grms 2-200 Hz Random ( <i>test without drives</i> )
<b>Vibration, Relocation</b>	0.15g 2-200 Hz sine ( <i>test with drives</i> ) 0.3g 2-200 Hz sine ( <i>test without drives</i> )
	19-in. Rack mount (2 EIA units)
<b>Rack Characteristics</b>	Back pressure not exceeding 5 pascals (0.5-mm water gauge)
<b>Safety and Approvals</b>	CE, UL, cUL EN 60950-1, IEC 60950-1, UL 60950-1
<b>EMC</b>	EN55022 (CISPR-A), FCC A

## Drive Carrier Specification

Please contact your supplier for details of approved drives.

**Important:** *Operating the Intel® Storage System SSR212CC with non-approved drives may invalidate the warranty.*

<b>Module Dimensions</b>	Height 26.6 mm Width 106.5 mm Depth 220.2 mm
<b>Weight</b>	0.8 kg (1.0" 300Gb drive)
<b>Transition Card</b>	Mounting locations for ATA - SATA drives with transition card attached
<b>Operating Temperature</b>	5° C to 35° C
<b>Power Dissipation</b>	14 Watts maximum

# A Intel® Server Board SE7520JR2 BIOS Settings

---

Before installing a new Intel® Server Board SE7520JR2, execute the following steps to ensure that the server board has the correct BIOS settings:

1. Connect a VGA monitor, keyboard and mouse to the storage system.
2. Power up the storage system and enter BIOS Setup by pressing <F2> at the BIOS bootup screen.
3. Press <F9> and then select <OK> to reset the BIOS to the default BIOS settings.
4. Make modifications to the BIOS as stipulated in following table.
5. When done, select <Save Custom Defaults> from the Exit menu.
6. Select <SAVE Changes and Exit>.

**Table 10. Intel® Server Board SE7520JR2 BIOS Settings**

<b>BIOS Setup Option</b>	<b>Feature</b>	<b>Setting</b>
IDE Configuration Menu	Onboard S-ATA Channels	Disabled
Floppy Configuratin Sub-menu Options	On-board Floppy Controller	Disabled
Event Log Configuration Sub-menu Selections	Clear All Event Logs	Enabled





# B RAID Levels

---

## RAID 0 - Data Striping

In RAID 0, data blocks are split into stripes based on the adjusted stripe size (for example, 128 KB) and the number of hard disks. Each stripe is stored on a separate hard disk. Significant improvement of the data throughput is achieved using this RAID level, especially with sequential read and write. RAID 0 includes no redundancy. When one hard disk fails, all data is lost. A single drive can be chosen as a RAID 0 drive as a method to pass a single drive through to the operating system; however, RAID 0 usually denotes two or more drives.

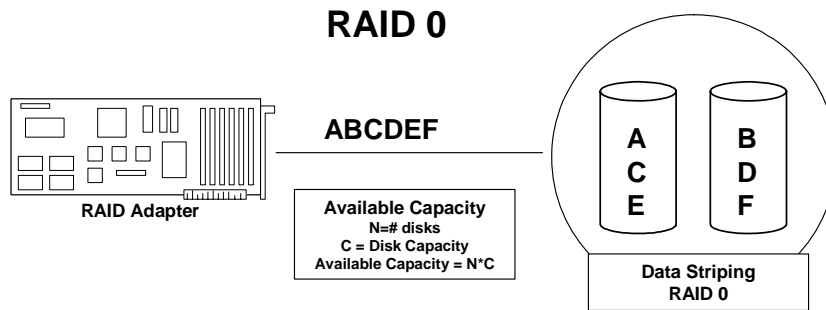


Figure 111. RAID 0 - Data Striping

## RAID 1 - Disk Mirroring / Disk Duplexing

All data is stored twice, once each on two identical hard disks making one drive a “mirror” image of the other. When one hard disk fails, all data is immediately available on the other without any impact on performance and data integrity.

With Disk Mirroring, two hard disks are mirrored on one I/O channel. If each hard disk is connected to a separate I/O channel, it is called Disk Duplexing.

RAID 1 represents an easy and highly efficient solution for data security and system availability. It is especially suitable for installations that are not too large (the available capacity is only half of the installed capacity). Disk mirroring requires two drives and each mirrored set is limited to two drives.

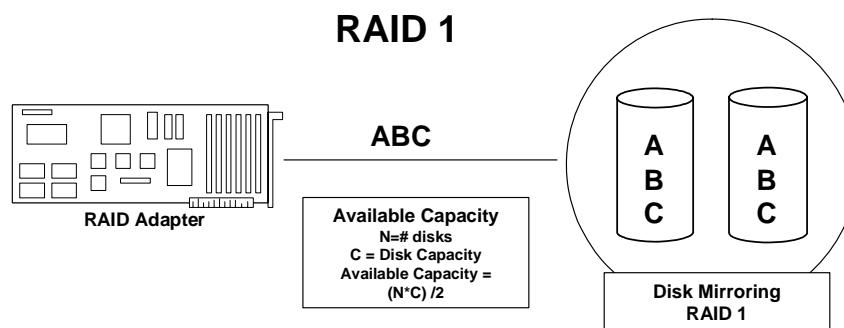


Figure 112. RAID 1 - Disk Mirroring / Disk Duplexing

## RAID 5 - Data Striping with Striped Parity

RAID 5 works in the same way as RAID 0. The data is striped across the hard disks and the controller calculates redundancy data (parity information) that is striped across all hard disks. Should one hard disk fail, all data remains fully available. Missing data is recalculated from existing data and parity information. The RAID 5 disk array delivers a balanced throughput. Even with small data blocks, which are very likely in a multi-tasking and multi-user environment, the response time is very good. RAID 5 is particularly suitable for systems with medium to large capacity requirements, due to the efficient ratio of installed and available capacity. RAID 5 requires a minimum of three drives in the configuration but can expand to the physical drive capacity of the controller.

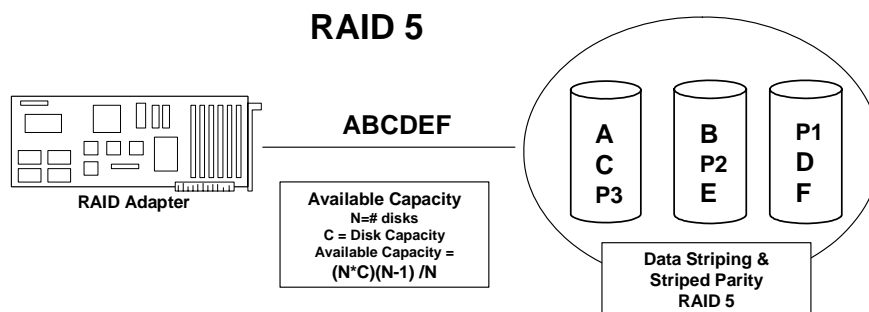


Figure 113. RAID 5 - Data Striping with Striped Parity

## RAID 10 - Combination of RAID 1 and RAID 0

RAID 10 is a combination of RAID 0 (performance) and RAID 1 (data security). Unlike RAID 5, there is no need to calculate parity information. RAID 10 disk arrays offer good performance and data security. As in RAID 0, optimum performance is achieved in highly sequential load situations. Identical to RAID 1, 50% of the installed capacity is lost through redundancy. RAID 10 will tolerate a drive failure of one drive per stripe. RAID 10 also requires a minimum of four drives and is set up by spanning two or more RAID 1 arrays. Up to eight RAID 1 arrays can be spanned in a RAID 10 configuration.

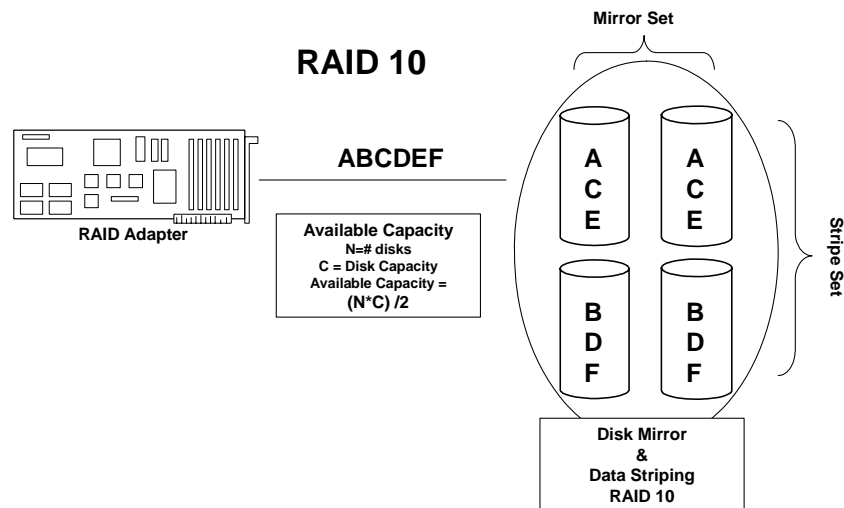


Figure 114. RAID 10 - Combination of RAID 1 and RAID 0

## RAID 50 - Combination of RAID 5 and RAID 0

Like RAID 10, RAID 50 is created by first creating multiple RAID 5 arrays and spanning a logical drive across them. RAID 50 arrays provide the excellent performance of RAID 5 with added data security. RAID 50 requires a minimum of six drives and can span a maximum of eight RAID 5 arrays. RAID 50 will tolerate a single drive failure per stripe.

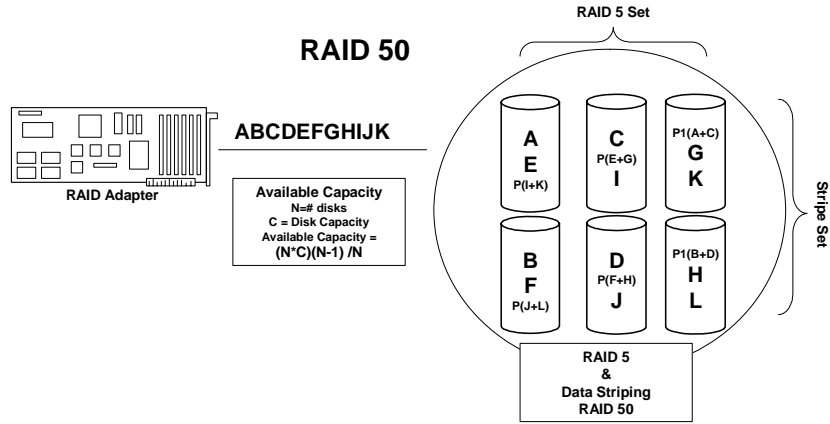


Figure 115. RAID 50 - Combination of RAID 5 and RAID 0

# C Upgrading Component Firmware

---

## Upgrading Component Firmware or the Server Board BIOS

If replacing an Intel® Server Board SE7520JR2 or Intel® RAID Controller, refer to the support site at <http://www.intel.com/support/motherboards/server/ssr212cc> for downloading the appropriate firmware or BIOS.

*Upgrading Component Firmware*

# D Safety Information

---

## English

### Server Safety Information

This document applies to Intel® server boards, Intel® server chassis (pedestal and rack-mount) and installed peripherals. To reduce the risk of bodily injury, electrical shock, fire, and equipment damage, read this document and observe all warnings and precautions in this guide before installing or maintaining your Intel® server product.







In the event of a conflict between the information in this document and information provided with the product or on the website for a particular product, the product documentation takes precedence.

Your server should be integrated and serviced only by technically qualified persons.

You must adhere to the guidelines in this guide and the assembly instructions in your server manuals to ensure and maintain compliance with existing product certifications and approvals. Use only the described, regulated components specified in this guide. Use of other products / components will void the UL Listing and other regulatory approvals of the product, and may result in noncompliance with product regulations in the region(s) in which the product is sold.

### Safety Warnings and Cautions

To avoid personal injury or property damage, before you begin installing the product, read, observe, and adhere to all of the following safety instructions and information. The following safety symbols may be used throughout the documentation and may be marked on the product and / or the product packaging.

<b>CAUTION</b>	Indicates the presence of a hazard that may cause minor personal injury or property damage if the CAUTION is ignored.
<b>WARNING</b>	Indicates the presence of a hazard that may result in serious personal injury if the WARNING is ignored.
	Indicates potential hazard if indicated information is ignored.
	Indicates shock hazards that result in serious injury or death if safety instructions are not followed.
	Indicates hot components or surfaces.
	Indicates do not touch fan blades, may result in injury.
	Indicates to unplug all AC power cord(s) to disconnect AC power
	Please recycle battery

## Intended Application Uses

This product was evaluated as Information Technology Equipment (ITE), which may be installed in offices, schools, computer rooms, and similar commercial type locations. The suitability of this product for other product categories and environments (such as medical, industrial, residential, alarm systems, and test equipment), other than an ITE application, may require further evaluation.

## Site Selection

The system is designed to operate in a typical office environment. Choose a site that is:

- Clean, dry, and free of airborne particles (other than normal room dust).
- Well-ventilated and away from sources of heat including direct sunlight and radiators.
- Away from sources of vibration or physical shock.
- Isolated from strong electromagnetic fields produced by electrical devices.
- In regions that are susceptible to electrical storms, we recommend you plug your system into a surge suppressor and disconnect telecommunication lines to your modem during an electrical storm.
- Provided with a properly grounded wall outlet.
- Provided with sufficient space to access the power supply cord(s), because they serve as the product's main power disconnect.

## Equipment Handling Practices

Reduce the risk of personal injury or equipment damage:

- Conform to local occupational health and safety requirements when moving and lifting equipment.
- Use mechanical assistance or other suitable assistance when moving and lifting equipment.
- To reduce the weight for easier handling, remove any easily detachable components.

## Power and Electrical Warnings

**Caution:** *The power button, indicated by the stand-by power marking, DOES NOT completely turn off the system AC power, 5V standby power is active whenever the system is plugged in. To remove power from system, you must unplug the AC power cord from the wall outlet. Your system may use more than one AC power cord. Make sure all AC power cords are*



*unplugged. Make sure the AC power cord(s) is/are unplugged before you open the chassis, or add or remove any non hot-plug components.*

*Do not attempt to modify or use an AC power cord if it is not the exact type required. A separate AC cord is required for each system power supply.*

*Some power supplies in Intel<sup>®</sup> servers use Neutral Pole Fusing. To avoid risk of shock use caution when working with power supplies that use Neutral Pole Fusing.*

*The power supply in this product contains no user-serviceable parts. Do not open the power supply. Hazardous voltage, current and energy levels are present inside the power supply. Return to manufacturer for servicing.*

*When replacing a hot-plug power supply, unplug the power cord to the power supply being replaced before removing it from the server.*

*To avoid risk of electric shock, turn off the server and disconnect the power cord, telecommunications systems, networks, and modems attached to the server before opening it.*

## Power Cord Warnings

If an AC power cord was not provided with your product, purchase one that is approved for use in your country.

**Caution:** *To avoid electrical shock or fire, check the power cord(s) that will be used with the product as follows:*

- *Do not attempt to modify or use the AC power cord(s) if they are not the exact type required to fit into the grounded electrical outlets*
- *The power cord(s) must meet the following criteria:*
- *The power cord must have an electrical rating that is greater than that of the electrical current rating marked on the product.*
- *The power cord must have safety ground pin or contact that is suitable for the electrical outlet.*
- *The power supply cord(s) is/are the main disconnect device to AC power. The socket outlet(s) must be near the equipment and readily accessible for disconnection.*
- *The power supply cord(s) must be plugged into socket-outlet(s) that is /are provided with a suitable earth ground.*

## System Access Warnings

**Caution:** *To avoid personal injury or property damage, the following safety instructions apply whenever accessing the inside of the product:*

- *Turn off all peripheral devices connected to this product.*
- *Turn off the system by pressing the power button to off.*
- *Disconnect the AC power by unplugging all AC power cords from the system or wall outlet.*

## Safety Information

- *Disconnect all cables and telecommunication lines that are connected to the system.*
- *Retain all screws or other fasteners when removing access cover(s). Upon completion of accessing inside the product, refasten access cover with original screws or fasteners.*
- *Do not access the inside of the power supply. There are no serviceable parts in the power supply. Return to manufacturer for servicing.*
- *Power down the server and disconnect all power cords before adding or replacing any non hot-plug component.*
- *When replacing a hot-plug power supply, unplug the power cord to the power supply being replaced before removing the power supply from the server.*

**Caution:** *If the server has been running, any installed processor(s) and heat sink(s) may be hot. Unless you are adding or removing a hot-plug component, allow the system to cool before opening the covers. To avoid the possibility of coming into contact with hot component(s) during a hot-plug installation, be careful when removing or installing the hot-plug component(s).*

**Caution:** *To avoid injury do not contact moving fan blades. If your system is supplied with a guard over the fan, do not operate the system without the fan guard in place.*

## Rack Mount Warnings

The equipment rack must be anchored to an unmovable support to prevent it from tipping when a server or piece of equipment is extended from it. The equipment rack must be installed according to the rack manufacturer's instructions.

Install equipment in the rack from the bottom up, with the heaviest equipment at the bottom of the rack.

Extend only one piece of equipment from the rack at a time.

You are responsible for installing a main power disconnect for the entire rack unit. This main disconnect must be readily accessible, and it must be labeled as controlling power to the entire unit, not just to the server(s).

To avoid risk of potential electric shock, a proper safety ground must be implemented for the rack and each piece of equipment installed in it.

## Electrostatic Discharge (ESD)

**Caution:** *ESD can damage disk drives, boards, and other parts. We recommend that you perform all procedures at an ESD workstation. If one is not available, provide some ESD protection by wearing an antistatic wrist strap attached to chassis ground -- any unpainted metal surface -- on your server when handling parts.*

*Always handle boards carefully. They can be extremely sensitive to ESD. Hold boards only by their edges. After removing a board from its protective wrapper or from the server, place the board component side up on a grounded, static free surface. Use a*

*conductive foam pad if available but not the board wrapper. Do not slide board over any surface.*

## Other Hazards

### Battery Replacement

**Caution:** *There is the danger of explosion if the battery is incorrectly replaced. When replacing the battery, use only the battery recommended by the equipment manufacturer.*

*Dispose of batteries according to local ordinances and regulations.*

*Do not attempt to recharge a battery.*

*Do not attempt to disassemble, puncture, or otherwise damage a battery.*

### Cooling and Airflow

**Caution:** *Carefully route cables as directed to minimize airflow blockage and cooling problems.*

*For proper cooling and airflow, operate the system only with the chassis covers installed. Operating the system without the covers in place can damage system parts. To install the covers:*

- *Check first to make sure you have not left loose tools or parts inside the system.*
- *Check that cables, add-in boards, and other components are properly installed.*
- *Attach the covers to the chassis according to the product instructions.*

### Laser Peripherals or Devices

**Caution:** *To avoid risk of radiation exposure and/or personal injury:*

- *Do not open the enclosure of any laser peripheral or device*
- *Laser peripherals or devices have are not user serviceable*
- *Return to manufacturer for servicing*

## Deutsch

### Sicherheitshinweise für den Server

Das vorliegende Dokument bezieht sich auf Intel® Serverplatinen, Intel® Servergehäuse (Standfuß und Rack) sowie installierte Peripheriegeräte. Es enthält Warnungen und Vorsichtsmaßnahmen zur Vermeidung von Gefahren durch Verletzung, Stromschlag, Feuer und Beschädigungen von Geräten. Lesen Sie diese Dokument daher sorgfältig, bevor Sie Ihr Intel® Serverprodukt installieren oder warten.







Bei Widersprüchen zwischen den hier vorliegenden Angaben und den Informationen im Lieferumfang des Produkts oder auf der Website des betreffenden Produkts hat die Produktdokumentation Vorrang.

Die Integration und Wartung des Servers darf nur durch technisch qualifizierte Personen erfolgen.

Um die Einhaltung der vorhandenen Zulassungen und Genehmigungen für das Produkt zu gewährleisten, sind die Richtlinien in diesem Handbuch sowie die Montageanleitungen in den Serverhandbüchern zu beachten. Verwenden Sie nur die beschriebenen, zugelassenen Komponenten, die im vorliegenden Handbuch angegeben werden. Die Verwendung anderer Produkte oder Komponenten führt zum Erlöschen der UL-Zulassung und anderer Genehmigungen für das Produkt. Dadurch kann das Produkt gegen Produktbestimmungen verstoßen, die im Verkaufsland gelten.

### Sicherheitshinweise und Vorsichtsmaßnahmen

Um Verletzungen und Beschädigungen zu vermeiden, sollten Sie vor dem Beginn der Produktinstallation die nachfolgend aufgeführten Sicherheitshinweise und -informationen sorgfältig lesen und befolgen. In dem vorliegenden Handbuch sowie auf dem Produkt und auf der Verpackung werden folgende Sicherheitssymbole verwendet:

<b>VORSICHT</b>	Weist auf eine Gefahrenquelle hin, die bei Nichtbeachtung des VORSICHTSHINWEISES zu leichteren Verletzungen bzw. Sachbeschädigungen führen kann.
<b>WARNUNG</b>	Weist auf eine Gefahrenquelle hin, die bei Nichtbeachtung der WARNUNG zu ernstesten Verletzungen führen kann.
	Weist auf potentielle Gefahr bei Nichtbeachtung der angezeigten Informationen hin.
	Weist auf die Gefahr eines Stromschlags hin, der bei Nichtbeachtung der Sicherheitshinweise zu schweren oder tödlichen Verletzungen führen kann.
	Weist auf Verbrennungsgefahr an heißen Bauteilen bzw. Oberflächen hin.
	Weist darauf hin, daß das Anfassen des Gebläses zu Verletzungen führen kann.
	Bedeutet, alle Netzkabel abzuziehen und das Gerät von der Netzspannung zu trennen.
	Bereiten Sie bitte Batterie auf

## Zielbenutzer der Anwendung

Dieses Produkt wurde in seiner Eigenschaft als IT-Gerät getestet, das in Büros, Schulen, Computerräumen und ähnlichen öffentlichen Räumlichkeiten installiert werden kann. Die Eignung dieses Produkts für andere Einsatzbereiche als IT (z. B. Medizin, Industrie, Alarmsysteme oder Prüfgeräte) kann u. U. weitere Tests erfordern.

## Standortauswahl

Das System ist für den Betrieb innerhalb normaler Büroumgebungen geeignet. Wählen Sie einen Standort, der folgenden Kriterien entspricht:

- Sauber, trocken und frei von Partikeln in der Luft (außer dem normalen Raumstaub).
- Gut belüftet, nicht in der Nähe von Wärmequellen und keiner direkten Sonnenbestrahlung ausgesetzt.
- Nicht in der Nähe von Vibrations- oder Erschütterungsquellen.
- Abgeschirmt von starken elektromagnetischen Feldern, die durch elektrische Geräte erzeugt werden.
- In gewittergefährdeten Gebieten sollten Sie das System an einen Überspannungsschutz anschließen und bei einem Gewitter die Telekommunikationskabel zum Modem abziehen.
- Eine ordnungsgemäß geerdete Wandsteckdose muß vorhanden sein.
- Ausreichender Freiraum für den Zugang zu den Netzkabeln, da diese die Hauptvorrichtung zum Trennen des Produkts von der Stromversorgung sind.

## Handhabung von Geräten

Beachten Sie zur Vermeidung von Verletzungen oder Beschädigungen an den Geräten die folgenden Hinweise:

- Halten Sie beim Transportieren und Anheben von Geräten die örtlichen Gesundheits- und Sicherheitsvorschriften ein.
- Verwenden Sie mechanische oder andere geeignete Hilfsmittel zum Transportieren oder Anheben von Geräten.
- Entfernen Sie alle Komponenten, die sich leicht abnehmen lassen, um das Gewicht zu reduzieren und die Handhabung zu erleichtern.

## Warnungen zu Netzspannung und Elektrizität

**Vorsicht:** Durch Betätigen der mit dem Standby-Symbol gekennzeichneten Netztaste wird das System NICHT vollständig vom Netz getrennt. Es sind weiterhin 5 V aktiv, solange das System eingesteckt ist. Um das System vollständig vom Strom zu trennen, muß das Netzkabel aus der Steckdose abgezogen werden. Das System verfügt möglicherweise über mehrere Netzkabel. Vergewissern Sie sich in diesem Fall, daß alle Netzkabel abgezogen sind. Wenn Sie Komponenten ein- oder ausbauen möchten, die nicht hot-plug-fähig sind, stellen Sie sicher, daß zuvor alle Netzkabel abgezogen sind.

Nehmen Sie keine Änderungen am Netzkabel vor, und verwenden Sie kein Kabel, das nicht genau dem geforderten Typ entspricht. Jedes Netzteil im System muß über ein eigenes Netzkabel angeschlossen werden.

Einige Netzteile von Intel Servern verwenden Nullleitersicherungen. Vorsicht ist geboten im Umgang mit Netzteilen, welche Nullleitersicherungen verwenden, um das Risiko eines elektrischen Schlages zu vermeiden

Das Netzteil in diesem Produkt enthält keine Teile, die vom Benutzer gewartet werden können. Öffnen Sie das Netzteil nicht. Im Netzteil bestehen gefährliche Spannungen, Ströme und Energiequellen. Schicken Sie das Gerät für Wartungsarbeiten an den Hersteller zurück.

Wenn Sie ein hot-plug-fähiges Netzteil austauschen, ziehen Sie dessen Netzkabel ab, bevor Sie es aus dem Server ausbauen.

Zur Vermeidung von Stromschlägen schalten Sie den Server aus, und trennen Sie vor dem Öffnen des Geräts das Netzkabel sowie alle an den Server angeschlossene Telekommunikationssysteme, Netzwerke und Modems.

## Hinweis für Netzkabel

Wenn kein Netzkabel mit dem Produkt geliefert wurde, kaufen Sie ein Kabel, das für die

**Vorsicht:** Prüfen Sie zur Vermeidung von Stromschlag- oder Feuergefahr die mit dem Produkt zu verwendenden Netzkabel wie folgt:

- Nehmen Sie keine Änderungen an einem Netzkabel vor, und benutzen sie es nicht, wenn es nicht genau in die geerdeten Netzsteckdosen paßt.
- Netzkabel müssen die folgenden Anforderungen erfüllen:
- Die Nennbelastbarkeit des Netzkabels muß mindestens so hoch sein wie die am Produkt angegebenen Nennstromaufnahme.
- Das Netzkabel muß einen zur Netzsteckdose passenden Schutzkontakt besitzen.
- Die Netzkabel sind die Hauptvorrichtung zum Trennen des Geräts vom Stromnetz. Die Steckdose muß in der Nähe der Anlage angebracht und gut erreichbar sein.
- Netzkabel müssen an eine ordnungsgemäß geerdete Steckdose angeschlossen sein.

## Warnhinweise für den Systemzugang

**Vorsicht:** Um Verletzungen und Beschädigungen zu vermeiden, sollten Sie vor Arbeiten im Produktinneren folgende Sicherheitsanweisungen beachten:

- Schalten Sie alle am Produkt angeschlossenen Peripheriegeräte aus.
- Schalten Sie das System mit dem Netzschalter aus.
- Trennen Sie das Gerät von der Stromquelle, indem Sie alle Netzkabel vom System bzw. aus der Steckdose ziehen.
- Ziehen Sie alle Kabel und alle an das System angeschlossenen Telekommunikationsleitungen ab.
- Bewahren Sie alle Schrauben und anderen Befestigungselemente gut auf, nachdem Sie die Gehäuseabdeckung entfernt haben. Wenn Sie Ihre Arbeiten im Systeminneren beendet haben, befestigen Sie die Gehäuseabdeckung mit den Originalschrauben bzw. -befestigungselementen.
- Führen Sie keine Arbeiten im Netzteil aus. Das Netzteil enthält keine für den Benutzer wartungsbedürftigen Teile. Schicken Sie das Gerät für Wartungsarbeiten an den Hersteller zurück.
- Schalten Sie den Server aus, und ziehen Sie alle Netzkabel ab, bevor Sie Komponenten ein- oder ausbauen, die nicht hot-plug-fähig sind.
- Wenn Sie ein hot-plug-fähiges Netzteil austauschen, ziehen Sie dessen Netzkabel ab, bevor Sie es aus dem Server ausbauen.

**Vorsicht:** War Ihr Server in Betrieb, können die installierten Prozessoren und Kühlkörper heiß sein. Sofern Sie keine Hot-Plug-Komponenten ein- oder ausbauen, warten Sie mit dem Abnehmen der Abdeckungen, bis das System abgekühlt ist. Gehen Sie beim Aus- oder Einbauen von Hot-Plug-Komponenten sorgfältig vor, um nicht mit heißen Komponenten in Berührung zu kommen.

**Vorsicht:** Berühren Sie nicht die rotierenden Lüfterflügel, um Verletzungen zu vermeiden. Falls Ihr System mit einer Lüfterabdeckung besitzt, darf es nicht ohne diese Abdeckung betrieben werden.

## Warnhinweise für Racks

Das Geräte-Rack muß auf einer geeigneten, festen Unterlage verankert werden, um ein Umkippen zu vermeiden, wenn ein Server oder andere Geräte herausgezogen werden. Bei der Installation des Racks müssen die Anweisungen des Rack-Herstellers beachtet werden.

Gehen Sie bei der Installation von Geräten im Rack immer von unten nach oben vor, und bauen Sie das schwerste Gerät an der untersten Position im Rack ein.

Ziehen Sie jeweils immer nur ein Gerät aus dem Rack heraus.

Sie müssen für die gesamte Rack-Einheit einen Netztrennschalter einrichten. Dieser Netztrennschalter muß leicht zugänglich sein und über eine Kennzeichnung verfügen, die besagt, daß er die Stromzufuhr zur gesamten Einheit steuert und nicht nur zu den Servern.

Zur Vermeidung von Stromschlaggefahr müssen das Rack selbst und alle darin eingebauten Geräte ordnungsgemäß geerdet sein.

## Elektrostatische Entladungen (ESD)

**Vorsicht:** *Elektrostatische Entladungen können zur Beschädigung von Festplatten, Platinen und anderen Komponenten führen. Daher sollten Sie alle Arbeiten an einer ESD-Workstation ausführen. Steht ein solcher Arbeitsplatz nicht zur Verfügung, erzielen Sie einen gewissen Schutz vor elektrostatischen Entladungen durch Tragen einer Antistatik-Manschette, die Sie während der Arbeit zur Erdung an einem beliebigen unlackierten Metallteil des Computergehäuses befestigen.*

*Gehen Sie bei der Handhabung von Platinen immer mit größter Vorsicht vor. Sie können äußerst empfindlich gegenüber elektrostatischer Entladung sein. Halten Sie Platinen nur an den Kanten fest. Legen Sie die Platinen nach dem Auspacken aus der Schutzhülle oder nach dem Ausbau aus dem Server mit der Bauelementseite nach oben auf eine geerdete, statisch entladene Unterlage. Verwenden Sie dazu, sofern verfügbar, eine leitfähige Schaumstoffunterlage, aber nicht die Schutzhülle der Platine. Ziehen Sie die Platine nicht über eine Fläche.*



## Andere Gefahren

### Batterieaustausch

**Vorsicht:** Wird die Batterie unsachgemäß ausgetauscht, besteht Explosionsgefahr. Verwenden Sie als Ersatz nur die vom Gerätehersteller empfohlene Batterie.

Beachten Sie bei der Entsorgung von Batterien die gültigen Bestimmungen.

Versuchen Sie nicht, eine Batterie aufzuladen.

Versuchen Sie nicht, eine Batterie zu öffnen oder sonstwie zu beschädigen.

### Kühlung und Luftstrom

**Vorsicht:** Verlegen Sie Kabel sorgfältig entsprechend der Anleitung, um Störungen des Luftstroms und Kühlungsprobleme zu vermeiden.

Zur Gewährleistung des ordnungsgemäßen Kühlungs- und Luftstromverhaltens darf das System nur mit angebrachten Gehäuseabdeckungen betrieben werden. Die Inbetriebnahme des Systems ohne Abdeckung kann zur Beschädigung von Systemkomponenten führen. So bringen Sie die Abdeckung wieder an:

- Vergewissern Sie sich zunächst, daß Sie keine Werkzeuge oder Teile im Gehäuse vergessen haben.
- Prüfen Sie, ob Kabel, Erweiterungskarten sowie weitere Komponenten ordnungsgemäß angebracht sind.
- Befestigen Sie die Abdeckungen am Gehäuse des Produkts, wie in dessen Anleitung beschrieben.

### Laser-Peripheriegeräte oder -Komponenten

**Vorsicht:** Beachten Sie zur Vermeidung von Strahlung und Verletzungen die folgenden Hinweise:

- Öffnen Sie keinesfalls das Gehäuse von Laser-Peripheriegeräten oder Laser-Komponenten.
- Laser-Peripheriegeräte oder -Komponenten besitzen keine für den Benutzer wartungsbedürftigen Teile.
- Schicken Sie das Gerät für Wartungsarbeiten an den Hersteller zurück.

## Français

### Consignes de sécurité sur le serveur

Ce document s'applique aux cartes serveur Intel®, au châssis de serveur Intel® (sur pieds et sur rack) et aux périphériques installés. Pour réduire les risques de dommages corporels, d'électrocution, d'incendie et de dommages matériels, lisez ce document et respectez tous les avertissements et précautions mentionnés dans ce guide avant d'installer ou de mettre à jour votre produit serveur Intel®.







En cas de conflit entre les informations fournies dans ce document et celles livrées avec le produit ou publiées sur le site Web pour un produit particulier, la documentation du produit prime.

Votre serveur doit être intégré et entretenu uniquement par des techniciens qualifiés.

Vous devez suivre les informations de ce guide et les instructions d'assemblage des manuels de serveur pour vérifier et maintenir la conformité avec les certifications et approbations de produit existantes. Utilisez uniquement les composants décrits et réglementés spécifiés dans ce guide. L'utilisation d'autres produits/composants annulera la liste UL et les autres approbations réglementaires du produit, et le produit peut ne pas être conforme aux autres lois et réglementations locales applicables au produit.

### Sécurité: avertissements et mises en garde

Pour éviter de vous blesser ou d'endommager votre équipement, lisez et respectez toutes les informations et consignes de sécurité avant de commencer l'installation du produit. Les symboles de sécurité suivants peuvent être utilisés tout au long de cette documentation et peuvent figurer sur le produit ou sur son emballage.

<b>ATTENTION</b>	Indique la présence d'un risque pouvant entraîner des blessures physiques mineures ou endommager légèrement le matériel si la mise en garde n'est pas prise en compte.
<b>AVERTISSEMENT</b>	Indique la présence d'un risque pouvant entraîner des blessures corporelles graves si l'avertissement n'est pas pris en compte.
	Indique un risque potentiel si les informations signalées ne sont pas prises en compte.
	Indique des risques d'électrocution pouvant entraîner des blessures corporelles graves ou mortelles si les consignes de sécurité ne sont pas respectées.
	Signale des composants ou des surfaces soumis à des températures élevées.
	Indique de ne pas toucher aux pales de ventilateur, car cela peut entraîner des blessures.
	Indique de débrancher tous les cordons d'alimentation secteur pour déconnecter l'alimentation.
	Veuillez réutiliser la batterie

## Domaines d'utilisation prévus

Ce produit a été testé comme équipement informatique (ITE) et peut être installé dans des bureaux, des écoles, des salles informatiques et des endroits commerciaux similaires. L'utilisation du présent produit dans des catégories et environnements de produits et domaines d'application (par exemple, le domaine médical, industriel, résidentiel, les systèmes d'alarme et les appareils de contrôle) autres qu'ITE doit faire l'objet d'évaluations supplémentaires.

## Sélection d'un emplacement

Le système est conçu pour fonctionner dans un environnement standard de bureau. Choisissez un emplacement respectant les conditions suivantes :

- Propre, sec et exempt de particules en suspension (autres que la poussière normale d'une pièce).
- Bien ventilé et à l'écart des sources de chaleur telles que la lumière directe du soleil et les radiateurs.
- À l'écart des sources de vibration ou des chocs physiques.
- Isolé des champs électromagnétiques importants produits par des appareils électriques.
- Dans les régions sujettes aux orages magnétiques, nous vous recommandons de brancher votre système à un suppresseur de surtension et de déconnecter les lignes de télécommunication de votre modem pendant les orages.
- Équipé d'une prise murale reliée à la terre.
- Équipé d'un espace suffisant pour accéder aux cordons d'alimentation secteur, car ils servent de disjoncteur principal d'alimentation du produit.

## Pratiques de manipulation de l'équipement

Réduisez le risque de dommages personnels ou matériels :

- Conformez-vous aux exigences de médecine du travail et de sécurité lorsque vous déplacez et soulevez le matériel.
- Utilisez l'assistance mécanique ou toute autre assistance appropriée lorsque vous déplacez et soulevez le matériel.
- Pour réduire le poids en vue de faciliter la manipulation, retirez tout composant amovible.

## Alimentation et avertissements en matière d'électricité

**Attention:** Le bouton d'alimentation, indiqué par le symbole de mise en veille, NE COUPE PAS complètement l'alimentation secteur du système car le courant de veille 5 V reste actif lorsque le système est sous tension. Pour couper l'alimentation du système, vous devez débrancher le cordon d'alimentation secteur de la prise murale. Votre système peut utiliser plusieurs cordons d'alimentation secteur. Assurez-vous que tous les cordons d'alimentation sont débranchés. Vous devez les débrancher avant d'ouvrir le châssis, d'ajouter ou de supprimer un composant non connectable à chaud.

Les alimentations de certains serveurs Intel sont munies de doubles fusibles pôle/neutre: veuillez observer les précautions d'usage afin d'éviter tout risque d'électrocution.

N'essayez pas de modifier ou d'utiliser un cordon d'alimentation secteur s'il ne s'agit pas du type exact requis. Un cordon secteur est requis pour chaque alimentation système.

Le bloc d'alimentation de ce produit ne contient aucun composant réparable par l'utilisateur. N'ouvrez pas le bloc d'alimentation. L'intérieur de celui-ci est soumis à des niveaux dangereux de tension, de courant et d'énergie. Renvoyez-le au fabricant en cas de problème.

Lorsque vous remplacez un bloc d'alimentation à chaud, débranchez le cordon du bloc d'alimentation en cours de remplacement avant de le retirer du serveur.

Pour éviter tout risque d'électrocution, mettez le système hors tension et débranchez les cordons d'alimentation ainsi que les systèmes de télécommunication, réseaux et modems reliés au système avant d'ouvrir ce dernier.

## Avertissements sur le cordon d'alimentation

Si aucun cordon d'alimentation secteur n'a été fourni avec votre produit, vous devez vous en procurer un qui soit approuvé pour une utilisation dans votre pays.

**Attention:** Pour éviter tout risque d'électrocution ou d'incendie, vérifiez les cordons d'alimentation qui seront utilisés avec le produit comme suit:

- N'essayez pas d'utiliser ou de modifier les cordons d'alimentation en CA s'ils ne correspondent pas exactement au type requis pour les prises électriques reliées à la terre.
- Les cordons d'alimentation doivent répondre aux critères suivants :
- Le cordon d'alimentation doit supporter une intensité supérieure à celle indiquée sur le produit.
- Le cordon d'alimentation doit posséder une broche ou un contact de mise à la terre approprié à la prise électrique.
- Les cordons d'alimentation électrique représentent le principal dispositif de déconnexion raccordé à l'alimentation secteur. Les prises de courant doivent se trouver à proximité de l'équipement et être facilement accessibles pour une déconnexion.
- Les cordons d'alimentation doivent être branchés sur des prises électriques correctement reliées à la terre.

## Avertissements sur l'accès au système

**Attention:** Pour éviter de vous blesser ou d'endommager votre équipement, les consignes de sécurité suivantes s'appliquent chaque fois que vous accédez à l'intérieur du produit:

- Mettez hors tension tous les périphériques connectés à ce produit.
- Éteignez le système en appuyant sur le bouton d'alimentation.
- Déconnectez l'alimentation secteur en débranchant tous les cordons d'alimentation secteur du système ou de la prise murale.
- Déconnectez l'ensemble des câbles et lignes de télécommunication qui sont connectés au système.
- Mettez toutes les vis ou autres attaches de côté lorsque vous retirez les panneaux d'accès. Une fois que vous avez terminé d'accéder à l'intérieur du produit, refixez le panneau d'accès avec les vis ou attaches d'origine.
- N'essayez pas d'accéder à l'intérieur du bloc d'alimentation. Il ne contient aucune pièce réparable. Renvoyez-le au fabricant en cas de problème.
- Mettez le serveur hors tension et débranchez tous les cordons d'alimentation avant d'ajouter ou de remplacer tout composant non connectable à chaud.
- Lorsque vous remplacez le bloc d'alimentation à chaud, débranchez le cordon du bloc d'alimentation en cours de remplacement avant de retirer le bloc du serveur.

**Attention:** Si le serveur a été utilisé, les processeurs et dissipateurs de chaleur installés peuvent être chauds. À moins que vous n'ajoutiez ou ne retiriez un composant connectable à chaud, laissez le système refroidir avant d'ouvrir les panneaux. Pour éviter tout risque d'entrer en contact avec un composant chaud lors d'une installation à chaud, prenez toutes les précautions nécessaires lorsque vous retirez ou installez des composants connectables à chaud.

**Attention:** Pour éviter de vous blesser, ne touchez pas les pales de ventilateur en mouvement. Si votre système est fourni avec une protection sur le ventilateur, ne mettez pas le système en route sans la protection en place.

## Avertissements sur le montage en rack

Le rack doit être fixé à un support inamovible pour éviter qu'il ne bascule lors de l'extension d'un serveur ou d'un élément de l'équipement. Le rack doit être installé conformément aux instructions du fabricant.

Installez les équipements dans le rack en partant du bas, en plaçant le plus lourd en bas du rack.

N'étendez qu'un seul élément de l'équipement à partir du rack à la fois.

Vous êtes responsable de l'installation d'un disjoncteur principal d'alimentation pour la totalité du rack. Ce disjoncteur principal doit être rapidement accessible et doit être étiqueté comme contrôlant toute l'unité, et pas uniquement le ou les serveurs.

Pour éviter tout risque d'électrocution, le rack et chaque élément de l'équipement installé dans le rack doivent être correctement reliés à la terre.

## Décharges électrostatiques (ESD)

**Attention:** *Les décharges électrostatiques (ESD) peuvent endommager les lecteurs de disque dur, les cartes et d'autres pièces. Il est fortement conseillé d'effectuer l'ensemble des procédures décrites à un poste de travail protégé contre les ESD. Au cas où aucun poste de ce type ne serait disponible, protégez-vous contre les ESD en portant un bracelet antistatique relié à la masse du châssis (n'importe quelle surface métallique non peinte) de votre serveur lorsque que vous manipulez les pièces.*

*Manipulez toujours les cartes avec précaution. Elles peuvent être extrêmement sensibles aux ESD. Ne tenez les cartes que par leurs bords. Après avoir retiré une carte de son emballage de protection ou du serveur, placez-la sur une surface reliée à la terre, exempte de charge statique, composants orientés vers le haut. Utilisez si possible un tapis de mousse conducteur, mais pas l'emballage de la carte. Veillez à ce que la carte ne glisse sur aucune surface.*

## Autres risques

### Remplacement de la pile

**Attention:** Il existe un risque d'explosion si la pile n'est pas correctement remplacée. Lors du remplacement de la pile, utilisez uniquement celle recommandée par le fabricant du matériel.

Mettez la pile au rebut en vous conformant aux réglementations locales.

N'essayez pas de recharger une pile.

N'essayez pas de démonter, de percer ou d'endommager la pile d'une quelconque façon.

### Refroidissement et ventilation

**Attention:** Routez les câbles avec précaution comme indiqué pour minimiser les blocages de circulation d'air et les problèmes de refroidissement.

Afin de permettre une ventilation et un refroidissement corrects, ne mettez le système en marche que lorsque les panneaux du châssis sont en place. L'utilisation du système sans les panneaux peut endommager les composants système. Pour installer les panneaux :

- Vérifiez tout d'abord que vous n'avez pas oublié d'outils ou de composants détachés à l'intérieur du système.
- Vérifiez que les câbles, les cartes d'extension et les autres composants sont correctement installés.
- Fixez les panneaux au châssis en suivant les instructions du produit.

### Périphériques laser

**Attention:** Pour éviter tout risque d'exposition aux rayonnements et/ou de dommage personnel:

- N'ouvrez pas l'enceinte d'un périphérique laser.
- Les périphériques laser ne sont pas réparables par l'utilisateur.
- Retournez-les au fabricant en cas de problème.

## Español

### Información de seguridad del servidor

Este documento se aplica a las tarjetas de servidor de Intel<sup>®</sup>, las carcassas de servidor de Intel<sup>®</sup> (montaje en bastidor y en pedestal) y los dispositivos periféricos. Para reducir el riesgo de daños corporales, descargas eléctricas, fuego y en el equipo, lea este documento y preste atención a todas las advertencias y precauciones de esta guía antes de instalar o mantener el producto de servidor de Intel<sup>®</sup>.







En el caso de que haya diferencias entre la información para un producto en particular contenida en este documento y la información proporcionada con dicho producto o en el sitio Web, la documentación del producto es la que prevalece.

Sólo personal técnico cualificado debe montar y prestar los servicios para el servidor.

Debe ceñirse a las directrices de esta guía y a las instrucciones de montaje de los manuales del servidor para asegurar y mantener el cumplimiento con las certificaciones y homologaciones existentes de los productos. Utilice sólo los componentes descritos y homologados que se especifican en esta guía. El uso de otros productos o componentes anulará la homologación UL y otras certificaciones oficiales del producto, pudiendo dejar de ser compatible con las normativas locales de los países en los que se comercializa.

### Advertencias y precauciones sobre seguridad

Para reducir la posibilidad de que se produzcan lesiones personales o daños en la propiedad, antes de empezar a instalar el producto, lea, observe y cumpla toda la información e instrucciones de seguridad siguientes. Puede que se utilicen los siguientes símbolos de seguridad en la documentación y es posible que aparezcan en el producto o en su embalaje.

<b>PRECAUCIÓN</b>	Indica la existencia de un riesgo que podría causar lesiones personales o daños en la propiedad leves si no se tiene en cuenta la PRECAUCIÓN.
<b>ADVERTENCIA</b>	Indica la existencia de un riesgo que podría causar lesiones personales graves si no se tiene en cuenta la ADVERTENCIA.
	Indica un riesgo potencial si no se tiene en cuenta la información indicada.
	Indica riesgo de descargas eléctricas que podrían causar lesiones graves o la muerte si no se siguen las instrucciones de seguridad.
	Indica componentes o superficies calientes.
	Indica que no se deben tocar las aspas de los ventiladores, ya que de lo contrario se podrían producir lesiones.
	Indica que es necesario desenchufar los cables de alimentación de CA para desconectar la alimentación de CA
	Recicle por favor la batería



## Aplicaciones y usos previstos

Este producto ha sido evaluado como equipo de tecnología informática (ITE) que puede instalarse en oficinas, escuelas, salas de equipos informáticos o lugares de ámbito comercial similares. Es posible que sea necesario llevar a cabo una evaluación adicional para comprobar si este producto es apropiado para otras categorías de productos y entornos además de las aplicaciones informáticas (por ejemplo, soluciones médicas, industriales, residenciales, sistemas de alarma y equipos de pruebas).

## Selección de la ubicación

El sistema se ha diseñado para funcionar en un entorno normal de oficinas. Seleccione una ubicación que esté:

- Limpia, seca y libre de macropartículas en suspensión en el aire (que no sean el polvo habitual de la habitación).
- Bien ventilada y alejada de fuentes de calor, incluida la luz solar directa y los radiadores.
- Alejada de fuentes de vibración o de golpes físicos.
- Aislada de campos electromagnéticos producidos por dispositivos eléctricos.
- En zonas propensas a tormentas eléctricas, se recomienda que conecte el servidor a un supresor de sobretensiones y desconecte las líneas de telecomunicaciones al módem durante una tormenta eléctrica.
- Provista de una toma de corriente alterna correctamente conectada a tierra.
- Provista de espacio suficiente para acceder a los cables de la fuente de alimentación ya que constituyen la desconexión principal de la alimentación.

## Manipulación del equipo

Reduzca el riesgo de daños personales o en el equipo:

- Respete los requisitos de sanidad y seguridad laborales de su país cuando traslade y levante el equipo.
- Utilice medios mecánicos u otros que sean adecuados al trasladar o levantar el equipo.
- Para que el peso sea menor para manipularlo con más facilidad, extraiga los componentes que sean de fácil extracción.

## Advertencias de alimentación y eléctricas

**Precaución:** El botón de encendido, indicado con la marca del modo de reposo o stand-by, NO DESCONECTA completamente la alimentación de CA del sistema, ya que el modo de reposo de 5 V sigue activo mientras el sistema está enchufado. Para desconectar el sistema debe desenchufar el cable de alimentación de CA de la toma de la pared. Puede usar más de un cable de alimentación de CA con el sistema. Asegúrese de que todos los cables de alimentación de CA estén desenchufados. Asegúrese de que los cables de alimentación de CA estén desenchufado antes de abrir la carcasa, agregar o extraer cualquier componente que no es de conexión en funcionamiento.

Algunas fuentes de alimentación de electricidad de los servidores de Intel utilizan el polo neutral del fuselaje. Para evitar riesgos de choques eléctricos use precauciones al trabajar con las fuentes de alimentación que utilizan el polo neutral de fuselaje.

No intente modificar ni utilizar un cable de alimentación de CA si no es del tipo exacto requerido. Se necesita un cable de CA para cada fuente de alimentación del sistema.

La fuente de alimentación de este producto no contiene piezas que puedan ser reparadas por el usuario. No abra la fuente de alimentación. Dentro de la fuente de alimentación puede haber niveles de tensión, corriente y energía peligrosos. Devuélvala al fabricante para repararla.

Al reemplazar una fuente de alimentación de conexión en funcionamiento, desenchufe el cable de alimentación de la fuente de alimentación que va a reemplazar antes de extraerla del servidor.

Para evitar el riesgo de descargas eléctricas, antes de abrir el servidor, apáguelo, desconecte el cable de alimentación, los sistemas de telecomunicaciones, las redes y los módems conectados al mismo.

## Advertencias sobre el cable de alimentación

Si no se ha proporcionado con el producto ningún cable de alimentación de CA, adquiera alguno cuyo uso esté aprobado en su país.

**Precaución:** Para evitar descargas eléctricas o fuego, revise los cables de alimentación que usará con el producto tal y como se describe a continuación:

- No intente modificar ni utilizar los cables de alimentación de CA si no son exactamente del modelo especificado para ajustarse a las tomas de corriente conectadas a tierra
- Los cables de alimentación deben reunir los siguientes requisitos:
- El cable de alimentación debe disponer de una capacidad nominal de corriente eléctrica mayor que la capacidad especificada en el producto.
- El cable de alimentación debe disponer de una patilla o contacto de conexión a tierra que sea apto para la toma de corriente.
- Los cables de la fuente de alimentación son los dispositivos de desconexión principales a la corriente alterna. El enchufe o enchufes de zócalo deben encontrarse cerca del equipo y el acceso a ellos debe poderse efectuar de forma inmediata con el fin de desconectarlos.

- Los cables de la fuente de alimentación deben estar conectados a los enchufes con una toma de tierra adecuada.

## Advertencias el acceso al sistema

**Precaución:** Para evitar lesiones personales o daños en la propiedad, se aplican las siguientes instrucciones de seguridad siempre que se acceda al interior del producto:

- Apague todos los dispositivos periféricos conectados a este producto.
- Pulse el botón de alimentación para apagar el sistema.
- Desconecte la alimentación de CA desenchufando los cables de alimentación de CA del sistema o de la toma de corriente alterna.
- Desconecte todos los cables y líneas de telecomunicación que estén conectados al sistema.
- Guarde todos los tornillos o elementos de fijación cuando retire las cubiertas de acceso. Cuando termine de operar en el interior del producto, vuelva a colocar los tornillos o los elementos de fijación originales de la cubierta de acceso.
- No acceda al interior de la fuente de alimentación. No hay elementos en la fuente de alimentación que usted pueda reparar y utilizar. Devuélvala al fabricante para repararla.
- Apague el servidor y desconecte todos los cables de alimentación antes de agregar o reemplazar cualquier componente que no es de conexión en funcionamiento.
- Al reemplazar una fuente de alimentación de conexión en funcionamiento, desenchufe el cable de alimentación de la fuente de alimentación que va a reemplazar antes de extraerla del servidor.

**Precaución:** Si el servidor se ha estado ejecutando, los procesadores y disipadores de calor estarán recalentados. A no ser que esté instalando o extrayendo un componente de conexión en funcionamiento, deje que el sistema se enfríe antes de abrir las cubiertas. Para que no llegue a tocar los componentes que estén calientes cuando esté realizando una instalación de conexión en funcionamiento, tenga cuidado al extraer o instalar los componentes de conexión en funcionamiento.

**Precaución:** Para evitar posibles daños, no toque las aspas en movimiento de los ventiladores. Si el sistema se le ha suministrado con una protección para el ventilador, asegúrese de que cuando esté funcionando el sistema la protección esté en su sitio.

## Advertencias sobre el montaje en bastidor

El bastidor del equipo se debe sujetar con un soporte fijo para evitar que se caiga cuando se extraiga un servidor o una pieza del mismo. El bastidor del equipo debe instalarse siguiendo las instrucciones del fabricante del bastidor.

Instale el equipo en el bastidor comenzando desde la parte de abajo, con el equipo más pesado en la parte inferior del bastidor.

Extraiga las piezas del equipo del bastidor de una a una.

El usuario es el responsable de la instalación de un dispositivo de desconexión de la alimentación principal para toda la unidad del bastidor. El acceso a este dispositivo de desconexión deberá ser de fácil acceso y deberán incluirse indicaciones que lo identifiquen como el control de alimentación eléctrica de toda la unidad, no sólo de los servidores.

Para evitar el riesgo de descargas eléctricas, deberá instalar una conexión a tierra apropiada para el bastidor y para cada pieza del equipo instalada en el mismo.

## Descarga electrostática (ESD)

**Precaución:** *Las descargas electrostáticas pueden dañar las unidades de disco, las tarjetas y otros componentes. Recomendamos que realice todos los procedimientos en una estación de trabajo protegida contra descargas electrostáticas. En caso de que no haya una disponible, protéjase de alguna forma contra las descargas llevando un brazalete antiestático conectado a la toma de tierra de la carcasa (cualquier superficie de metal que no esté pintada) del servidor cuando manipule las piezas.*

*Manipule siempre las tarjetas con el máximo cuidado. Pueden ser sumamente sensibles a las descargas electrostáticas. Sujételas sólo por los bordes. Una vez extraída la tarjeta de su envoltorio de protección o del servidor, colóquela con el lado de los componentes hacia arriba sobre una superficie con toma de tierra y sin carga estática. Utilice una almohadilla de espuma conductora si dispone de ella, pero nunca el envoltorio de la tarjeta. No deslice la tarjeta sobre ninguna superficie.*

## Sustitución de la batería

**Precaución:** Existe el peligro de explosión si la batería no se reemplaza correctamente. Al reemplazar la batería, utilice sólo la batería recomendada por el fabricante del equipo.

*Deseche las baterías respetando la normativa local.*

*No intente recargar la batería.*

*No intente desmontar, pinchar o causar cualquier otro desperfecto a una batería.*

## Enfriamiento y circulación de aire

**Precaución:** El tendido de los cables debe realizarse cuidadosamente tal y como se le indica para reducir al mínimo los problemas de obstrucción de la ventilación y de refrigeración.

*Para conseguir una refrigeración y corriente de aire adecuadas, compruebe que cuando sistema esté funcionando, las cubiertas de la carcasa están instaladas. Si utiliza el sistema sin las cubiertas, podría dañar sus componentes. Para instalar las cubiertas:*

- *Compruebe primero que no ha dejado herramientas o piezas sueltas dentro del sistema.*
- *Compruebe que los cables, tarjetas adicionales y otros componentes están instalados correctamente.*
- *Sujete las cubiertas a la carcasa siguiendo las instrucciones del producto.*

## Periféricos o dispositivos láser

**Precaución:** Para evitar el riesgo de la exposición a radiaciones o de daños personales:

- *No abra la caja de ningún periférico o dispositivo láser*
- *Los periféricos o dispositivos láser no pueden ser reparados por el usuario*
- *Haga que el fabricante los repare.*

## 简体中文

### 服务器安全信息

本文档适用于 Intel® 服务器主板、Intel® 服务器机箱（基座和机架固定件）和已安装的外设。为减少人身伤害、电击、火灾以及设备损坏的危险，请在安装或维护 Intel® 服务器产品之前阅读本文档并遵循本指南中的所有警告和预防措施。






如果本文档中的信息与特定产品的随附信息或 Web 站点信息之间存在不一致，请以产品文档为准。

服务器须由合格的技术人员进行集成和维护。

必须遵守本指南的规定和服务器手册的装配指导，以确保符合现有的产品认证和审批。仅使用本指南中描述和规定的指定组件。使用其他产品 / 组件将使产品的 UL 认证和其他管理审批无效，并可能导致产品不符合销售地的产品法规。

### 安全警告与注意事项

为避免人身伤害与财产损失，安装本产品之前，请阅读以下所有安全指导和信息。下面所列的安全符号可能在整个文档中使用并可能标注于产品和 / 或产品包装之上。

<b>注意</b>	表示如果无视此“?? ?项”?????? 轻微人身伤害或财产损失的危险。
<b>警告</b>	表示如果无视此“?? ”?????? 严重人身伤害的危险。
	表示如果无视所示信息，即存在潜在的危险。
	表示如果不遵守安全指导，存在可导致严重伤害或死亡的电击危险。
	表示灼热组件或表面。
	表示请勿触摸风机叶片，否则可能致伤。
	表示拔下所有交流电线，断开交流电源

## 预期应用使用

根据评估，本产品为信息技术设备 (ITE)，可安装在办公室、学校、计算机房和类似的商业场所。本产品对于非 ITE 应用的其他产品种类和环境（如医疗、工业、住宅、报警系统和测试设备）的适用性尚有待进一步的评估。

## 场地选择

本系统专为在典型办公环境运行而设计。请选择符合以下条件的地点：

- 清洁、干燥，无气载微粒（而非一般的室内尘埃）。
- 通风良好，远离热源（包括直接日晒和散热器）。
- 远离振动源或物理震动。
- 与电气设备产生的强大电磁场隔离。
- 在易受闪电袭击的地区，我们建议将系统插入电涌抑制器并在闪电期间断开通信线路与调制解调器之间的连接。
- 提供正确接地的墙壁插座。
- 提供足够的空间，以便拿取电源供应线，因为这是本产品的主要电源断开器。

## 设备操作规范

减少人身伤害或设备受损的危险：

- 移举设备时遵守当地的职业健康与安全要求。
- 借助机械手段或其他合适的手段移举设备。
- 拆除一切易分离组件，以降低重量并方便操作。

## 电源与电气警告

### 注意事项

电源按钮（如待机电源标记所示）并不能完全关闭系统的交流电源，只要系统已接通电源，就存在 5V

待机电源。要从系统切断电源，须从墙壁电源插座中拔下交流电线。您的系统可能不止使用一根交流电线。请确保所有的交流电线都已拔下。打开机箱或增加或删除任何热插拔组件之前，确保交流电线已拔下。

若非所需的确切类型，请勿尝试修改或使用交流电线。系统的每个电源供应设备都需要一根单独的交流电线。

本产品的电源供应设备包含非用户维修部件。请勿打开电源供应设备。电源供应设备包含非常危险的电压级、电流级和能量级。请与生产商联系维修事宜。

替换热插拔电源供应设备时，请先拔下需替换的电源供应设备上的电源线，再将其从服务器上移除。

为避免电击，请在打开服务器之前，关闭服务器并断开服务器上连接的电源线、电信系统、网络和调制解调器。

## 电源线警告

如果产品未提供交流电线，请购买一根您所在国家批准使用的交流电线。

### 注意事项

为避免电击或火灾危险，请按如下所述对产品所用的电源线进行检查：

- 若非所需的符合接地插座的确切类型，请勿尝试修改或使用交流电线
- 电源线须符合以下标准：
  - 电源线的电气额定值须大于产品上标注的电流额定值。
  - 电源线须拥有适合插座的安全接地插头或触点。
- 电源线为交流电源的主要断开设备。插座须靠近设备并可随时断开。
- 电源线须插入所提供的拥有合适接地的插座。

## 系统使用警告

### 注意事项

为避免人身伤害或财产损失，无论何时检查产品内部，以下安全指导都适用：

- 关闭所有与本产品相连的外设。
- 按下电源按钮至关闭状态，关闭系统。
- 从系统或墙壁插座上拔下所有交流电线，断开交流电源。
- 断开与系统相连的所有线缆和通信线路。
- 卸除舱口盖时，保留所有螺钉及其他紧固件。完成产品内部检查之后，请用螺钉或紧固件重新固定舱口盖。
- 请勿打开电源供应设备。电源供应设备内没有可维修部件。请与生产商联系维修事宜。
- 增加或替换任何非热插拔组件之前，请关闭服务器电源并断开所有电源线。
- 替换热插拔电源供应设备时，请先拔下需替换的电源供应设备上的电源线，然后再从服务器上移除电源供应设备。

### 注意事项

如果服务器一直在运行，任何已安装的处理器和吸热设备都可能很热。除非要增加或移除热插拔组件，否则请待系统冷却后再开盖。为避免在热插拔组件安装过程中接触灼热组件，移除或安装热插拔组件时务须小心。



## 注意事项

为避免受伤，请勿触摸运转的风机叶片。如果系统的风机上配有防护装置，请勿卸下风机防护装置运行系统。

## 机架固定件警告

设备的机架须固定在稳固的支座上，以防从中安装服务器或设备时倒塌。须按照机架生产商提供的安装说明进行安装。

从下往上将设备安装在机架上，最重的设备安装在机架的最底层。

一次只从机架上安装一件设备。

您须负责安装整个机架装置的主要电源断开设备。此主要断开设备须随时可用，且须标明为控制整个装置（而不仅限于服务器）的电源。

为避免潜在的电击危险，须对机架及其上所安装的每一件设备实行正确的安全接地。

## 静电放电 (ESD)

### 注意事项

ESD 会损坏磁盘驱动器、主板及其他部件。我们建议您执行 ESD 工作站的所有步骤。如果没有 ESD

工作站，则采取一些静电放电保护措施，操作部件时，戴上与服务器上的机箱接地或任何未喷漆金属表面连接的防静电腕带。

操作主板时始终保持小心。它们可能对 ESD

非常敏感。拿持主板时只接触边缘。从保护包装中或从服务器上取出主板后，请将主板组件侧面朝上放置于无静电的接地表面上。请使用导电泡沫垫（若有），不要使用主板包装。请勿将主板在任何表面上滑动。

## 其他危险

### 替换电池

#### 注意事项

不正确替换电池可能导致爆炸危险。替换电池时，请只使用设备生产商推荐使用的电池。

请按当地法规处置电池。

请勿对电池充电。

请勿拆卸、刺穿或以其他方式损坏电池。

### 冷却和气流

#### 注意事项

按照说明小心布置线缆，尽量减少气流阻塞和冷却问题。

为保证适当的冷却和气流，运行系统时请确保机箱盖已安装。未安装机箱盖即运行系统可能导致系统部件受损。安装机箱盖的步骤如下：

- 首先检查并确保系统内没有遗留的未固定工具或部件。
- 检查线缆、内插板和其他组件已正确安装。
- 按产品说明安装机箱盖。

### 激光外设或激光设备

#### 注意事项

为避免幅射暴露和 / 或人身伤害：

- 请勿打开任何激光外设或激光设备的外壳
- 激光外设或激光设备为非用户维修设备

请与生产商联系维修事宜

# E Intel<sup>®</sup> Server Issue Report Form

---

*Note: An on-line / automatic submission version of this form is available at <http://support.intel.com/support/motherboards/server/ssr212cc/>. For the fastest service, please submit your form via the Internet.*

Date Submitted: \_\_\_\_\_

Company Name: \_\_\_\_\_

Contact Name: \_\_\_\_\_

Email Address: \_\_\_\_\_

Intel Server Product: \_\_\_\_\_

Priority (Critical, Hot, High, Low): \_\_\_\_\_

Brief Problem Description. Provide a brief description below. See the last page for space to include a detailed problem description.

\_\_\_\_\_  
\_\_\_\_\_  
\_\_\_\_\_  
\_\_\_\_\_  
\_\_\_\_\_

## Board / Chassis Information

Chassis Serial Number: \_\_\_\_\_

Baseboard Revision - PBA#: \_\_\_\_\_

Baseboard Serial Number: \_\_\_\_\_

Chassis Model: \_\_\_\_\_

CPU1 Speed/Stepping/Spec: \_\_\_\_\_

System BIOS Version: \_\_\_\_\_

HSC Firmware Version: \_\_\_\_\_

## DIMM Configuration

DIMM1A MB and Vendor / part number: \_\_\_\_\_

DIMM1B MB and Vendor / part number: \_\_\_\_\_

DIMM2A MB and Vendor / part number: \_\_\_\_\_

DIMM2B MB and Vendor / part number: \_\_\_\_\_

DIMM3A MB and Vendor / part number: \_\_\_\_\_

DIMM3B MB and Vendor / part number: \_\_\_\_\_

DIMM4A MB and Vendor / part number: \_\_\_\_\_

DIMM4B MB and Vendor / part number: \_\_\_\_\_

## Operating System Information

Operating System: \_\_\_\_\_

Version: \_\_\_\_\_

Service Pack: \_\_\_\_\_

## Add-in Card, Peripheral, Video, NIC

Check each box below as applicable, and provide the requested information.

Peripheral Card or Peripheral Description Driver Revision IRQ # I/O Base Address NIC

X	Peripheral	Description	Driver Revision	IRQ	I/O Base Address	FW Revision
	<b>Full-height Riser</b>					
	PCI Slot 1					
	PCI Slot 2					
	PCI Slot 3					
	<b>Video</b>					
	On-board Video					
	Add-in Video					
	<b>NIC</b>					
	On-Board NIC1					
	On-Board NIC2					





# F Getting Help

---

## World Wide Web

<http://support.intel.com/support/motherboards/server/ssr212cc/>.

## Telephone

All calls are billed US \$25.00 per incident, levied in local currency at the applicable credit card exchange rate plus applicable taxes. (Intel reserves the right to change the pricing for telephone support at any time without notice).

Before calling, fill out an “[Intel® Server Issue Report Form](#)”. A sample form is provided on the following pages. However, for the fastest service, please submit your form via the Internet.

For an updated support contact list, see <http://www.intel.com/support/9089.htm/>

## U.S. and Canada

1-800-404-2284

## Europe

**Belgium** ..... 02 714 3182

**Denmark** ... 38 487077

**Finland** ..... 9 693 79297

**France**..... 01 41 918529

**Germany** ... 069 9509 6099

**Holland** ..... 020 487 4562

**Italy**..... 02 696 33276

**Norway** ..... 23 1620 50

**Spain**..... 91 377 8166

**Sweden**..... 08 445 1251

**UK**..... 870 6072439

## In Asia-Pacific region

**Australia**.... 1800 649931

**Cambodia**.. 63 2 636 9797 (via Philippines)

**China** ..... 800 820 1100 (toll-free)  
..... 8 621 33104691 (not toll-free)

**Hong Kong** 852 2 844 4456

**India**..... 0006517 2 68303634 (manual toll-free. You need an IDD-equipped telephone)

**Indonesia** ... 803 65 7249

**Korea** ..... 822 767 2595

**Malaysia** .... 1 800 80 1390

**Myanmar**... 63 2 636 9796 (via Philippines)

**New Zealand** 0800 444 365

**Pakistan**.... 632 63684 15 (IDD via Philippines)

**Philippines** 1 800 1 651 0117

**Singapore** .. 65 6213-1311

**Taiwan** ..... 2 2545-1640

**Thailand** .... 1 800 631 0003

**Vietnam** ..... 632 6368416 (IDD via Philippines)

## Japan

**Domestic**.... 0120 868686

**Outside country** 81 298 47 0800

## Latin America

**Argentina** .. Contact AT&T USA at 0-800 222 1288. Once connected, dial 800 843 4481

**Brazil** ..... 001-916 377 0180

**Chile**

**Easter Island.** ..... Contact AT&T USA at 800 800 311. Once connected, dial 800 843 4481

**Mainland and Juan** .. Contact AT&T USA at 800 225 288. Once connected, dial 800 843 4481



**Colombia**... Contact AT&T USA at 01 800 911 0010. Once connected, dial 800 843 4481

**Costa Rica** . Contact AT&T USA at 0 800 0 114 114. Once connected, dial 800 843 4481

**Ecuador**

**(Andimate)** .... Contact AT&T USA at 1 999 119. Once connected, dial 800 843 4481

**(Pacifictel)** ..... Contact AT&T USA at 1 800 225 528. Once connected, dial 800 843 4481

**Guatemala**. Contact AT&T USA at 99 99 190. Once connected, dial 800 843 4481

**Mexico** ..... Contact AT&T USA at 001 800 462 628 4240. Once connected, dial 800 843 4481

**Miami** ..... 1 800 621 8423

**Panama**..... Contact AT&T USA at 00 800 001 0109. Once connected, dial 800 843 4481

**Paraguay** ... 001 916 377 0114

**Peru** ..... 001 916 377 0114

**Uruguay**..... 001 916 377 0114

**Venezuela**... Contact AT&T USA at 0 800 2255 288. Once connected, dial 800 843 4481

*Getting Help*

# G Regulatory and Compliance Information

---

## Product Regulatory Compliance

**Warning:** *To ensure regulatory compliance, you must adhere to the assembly instructions in this guide to ensure and maintain compliance with existing product certifications and approvals. Use only the described, regulated components specified in this guide. Use of other products/components will void the UL listing and other regulatory approvals of the product and will most likely result in noncompliance with product regulations in the region(s) in which the product is sold.*

*To help ensure EMC compliance with your local regional rules and regulations, before computer integration, make sure that the chassis, power supply, and other modules have passed EMC testing using a server board with a microprocessor from the same family (or higher) and operating at the same (or higher) speed as the microprocessor used on this server board. The final configuration of your end system product may require additional EMC compliance testing. For more information, please contact your local Intel representative.*

*This is an FCC Class A device. Integration of it into a Class B chassis does not result in a Class B device.*

## Product Safety Compliance

This product, when correctly integrated per this guide, complies with the following safety and electromagnetic compatibility (EMC) regulations.

## Intended Application

This product was evaluated as Information Technology Equipment (ITE), which may be installed in offices, schools, computer rooms, and similar commercial type locations. The suitability of this product for other product categories and environments (such as: medical, industrial, telecommunications, NEBS, residential, alarm systems, test equipment, etc.), other than an ITE application, may require further evaluation.

## Product Safety Compliance

This product complies with the following product safety requirements:

- UL60950 - CSA 60950 (USA / Canada)
- EN60950 (Europe)
- IEC60950 (International)
- CB Certificate & Report, IEC60950 (report to include all country national deviations)

- GS License (Germany)
- GOST R 50377-92 - License (Russia)
- Belarus License (Belarus)
- Ukraine License (Ukraine)
- CE - Low Voltage Directive 73/23/EEE (Europe)
- IRAM Certification (Argentina)
- GB4943- CNCA Certification (China)

## **Product EMC Compliance - Class A Compliance**

This product has been tested and verified to comply with the following electromagnetic compatibility (EMC) regulations when installed in a compatible Intel® host system. For information on compatible host system(s) refer to Intel's Server Builder Web site or contact your local Intel representative.

- FCC /ICES-003 - Emissions (USA/Canada) Verification
- CISPR 22 - Emissions (International)
- EN55022 - Emissions (Europe)
- EN55024 - Immunity (Europe)
- EN61000-3-2 - Harmonics (Europe)
- EN61000-3-3 - Voltage Flicker (Europe)
- CE - EMC Directive 89/336/EEC (Europe)
- VCCI Emissions (Japan)
- AS/NZS 3548 Emissions (Australia / New Zealand)
- BSMI CNS13438 Emissions (Taiwan)
- GOST R 29216-91 Emissions (Russia)
- GOST R 50628-95 Immunity (Russia)
- Belarus License (Belarus)
- Ukraine License (Ukraine)
- RRL MIC Notice No. 1997-41 (EMC) & 1997-42 (EMI) (Korea)
- GB 9254 - CNCA Certification (China)
- GB 17625 - (Harmonics) CNCA Certification (China)

## **Certifications / Registrations / Declarations**




- UL Certification (US/Canada)
- CE Declaration of Conformity (CENELEC Europe)
- FCC/ICES-003 Class A Attestation (USA/Canada)

- VCCI Certification (Japan)
- C-Tick Declaration of Conformity (Australia)
- MED Declaration of Conformity (New Zealand)
- BSMI Certification (Taiwan)
- GOST R Certification / License (Russia)
- Belarus Certification / License (Belarus)
- RRL Certification (Korea)
- IRAM Certification (Argentina)
- CNCA Certification (China)
- Ecology Declaration (International)





## Product Regulatory Compliance Markings

This product bears the following regulatory marks.

**Table 11. Product Regulatory Compliance Markings**

Regulatory Compliance	Country	Marking
cULus Listing Marks	USA/Canada	
GS Mark	Germany	
CE Mark	Europe	
FCC Marking (Class A)	USA	This device complies with Part 15 of the FCC Rules. Operation of this device is subject to the following two conditions: (1) This device may not cause harmful interference, and (2) This device must accept any interference received, including interference that may cause undesired operation. Manufactured by Intel Corporation
EMC Marking (Class A)	Canada	CANADA ICES-003 CLASS A CANADA NMB-003 CLASSE A
VCCI Marking (Class A)	Japan	この装置は、クラス A 情報技術装置です。この装置を家庭環境で使用すると電波妨害を引き起こすことがあります。この場合には使用者が適切な対策を講ずるよう要求されることがあります。VCCI-A

**Table 11. Product Regulatory Compliance Markings**

Regulatory Compliance	Country	Marking
BSMI Certification Number & Class A Warning	Taiwan	 <div data-bbox="883 541 1305 646" style="border: 1px solid black; padding: 5px;"> <p>警告使用者： 這是甲類的資訊產品，在居住的環境中使用時，可能會造成射頻干擾，在這種情況下，使用者會被要求採取某些適當的對策</p> </div>
GOST R Marking	Russia	
RRL MIC Mark	Korea	 <p>인증번호: CPU</p> <p>See the regulatory information document for additional information.</p>
China Compulsory Certification Mark	China	

## Electromagnetic Compatibility Notices

### FCC Verification Statement (USA)

This device complies with Part 15 of the FCC Rules. Operation is subject to the following two conditions: (1) this device may not cause harmful interference, and (2) this device must accept any interference received, including interference that may cause undesired operation.

For questions related to the EMC performance of this product, contact:

Intel Corporation  
5200 N.E. Elam Young Parkway  
Hillsboro, OR 97124-6497  
1-800-628-8686

This equipment has been tested and found to comply with the limits for a Class A digital device, pursuant to Part 15 of the FCC Rules. These limits are designed to provide reasonable protection against harmful interference in a residential installation. This equipment generates, uses, and can radiate radio frequency energy and, if not installed and used in accordance with the instructions, may cause harmful interference to radio communications. However, there is no guarantee that interference will not occur in a particular installation. If this equipment does cause harmful interference to radio or television reception, which can be determined by turning the equipment off and on, the user is encouraged to try to correct the interference by one or more of the following measures:

- Reorient or relocate the receiving antenna.
- Increase the separation between the equipment and the receiver.
- Connect the equipment to an outlet on a circuit other than the one to which the receiver is connected.
- Consult the dealer or an experienced radio/TV technician for help.

Any changes or modifications not expressly approved by the grantee of this device could void the user's authority to operate the equipment. The customer is responsible for ensuring compliance of the modified product.

Only peripherals (computer input/output devices, terminals, printers, etc.) that comply with FCC Class A or B limits may be attached to this computer product. Operation with noncompliant peripherals is likely to result in interference to radio and TV reception.

All cables used to connect to peripherals must be shielded and grounded. Operation with cables, connected to peripherals, that are not shielded and grounded may result in interference to radio and TV reception.

## Industry Canada (ICES-003)

Cet appareil numérique respecte les limites bruits radioélectriques applicables aux appareils numériques de Classe A prescrites dans la norme sur le matériel brouilleur: "Appareils Numériques", NMB-003 édictée par le Ministre Canadien des Communications.

English translation of the notice above:

This digital apparatus does not exceed the Class A limits for radio noise emissions from digital apparatus set out in the interference-causing equipment standard entitled: "Digital Apparatus," ICES-003 of the Canadian Department of Communications.

## Europe (CE Declaration of Conformity)

This product has been tested in accordance to, and complies with the Low Voltage Directive (73/23/EEC) and EMC Directive (89/336/EEC). The product has been marked with the CE Mark to illustrate its compliance.

## VCCI (Japan)

この装置は、情報処理装置等電波障害自主規制協議会（VCCI）の基準に基づくクラスA情報技術装置です。この装置を家庭環境で使用すると電波妨害を引き起こすことがあります。この場合には使用者が適切な対策を講ずるよう要求されることがあります。

English translation of the preceding notice:

This is a Class A product based on the standard of the Voluntary Control Council for Interference (VCCI) from Information Technology Equipment. If this is used near a radio or television receiver in a domestic environment, it may cause radio interference. Install and use the equipment according to the instruction manual.

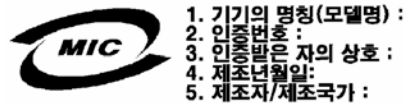
## BSMI (Taiwan)

**警告使用者：**  
這是甲類的資訊產品，在居住的環境中使用時，可能會造成射頻干擾，在這種情況下，使用者會被要求採取某些適當的對策

The BSMI Certification Marking and EMC warning is located on the outside rear area of the product.

## Korean Compliance (RRL)

Following is the RRL certification information for Korea.



English translation of the notice above:

1. Type of Equipment (Model Name): On License and Product
2. Certification No.: On RRL certificate. Obtain certificate from local Intel representative
3. Name of Certification Recipient: Intel Corporation
4. Date of Manufacturer: Refer to date code on product
5. Manufacturer/Nation: Intel Corporation/Refer to country of origin marked on product

## Regulated Specified Components

To maintain the UL listing and compliance to other regulatory certifications and/or declarations, the following regulated components must be used and conditions adhered to. Interchanging or use of other components will void the UL listing and other product certifications and approvals.

Updated product information for configurations can be found on the Intel Server Builder Web site at the following URL:

<http://channel.intel.com/go/serverbuilder>



If you do not have access to Intel's Web address, please contact your local Intel representative.

- **Chassis:** (base chassis is provided with power supply and fans) - UL listed.
- **Server board:** you must use an Intel server board - UL recognized.
- **Add-in boards:** must have a printed wiring board flammability rating of minimum UL94V-1. Add-in boards containing external power connectors and/or lithium batteries must be UL recognized or UL listed. Any add-in board containing modem telecommunication circuitry must be UL listed. In addition, the modem must have the appropriate telecommunications, safety, and EMC approvals for the region in which it is sold.
- **Peripheral Storage Devices:** must be a UL recognized or UL listed accessory and TUV or VDE licensed. Maximum power rating of any one device is 19 watts. Total server configuration is not to exceed the maximum loading conditions of the power supply.

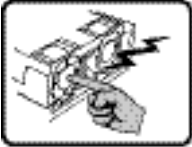
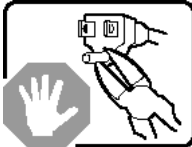
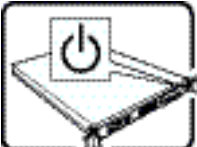

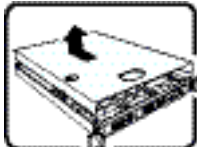
## **End of Life / Product Recycling**

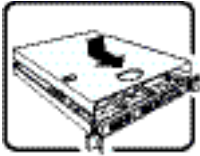
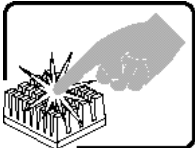
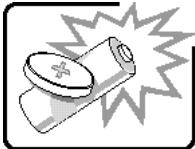
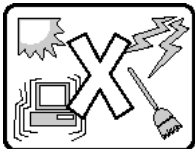
Product recycling and end-of-life take back systems and requirements vary from country to country. Contact the retailer or distributor of this product for information on product recycling and / or take back.

*Regulatory and Compliance Information*

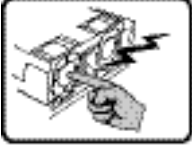
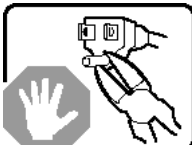
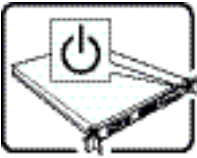

# H Installation/Assembly Safety Instructions

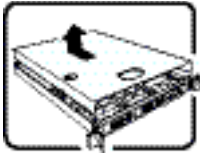
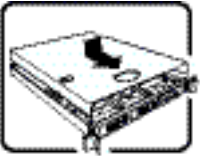
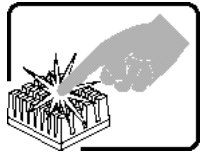
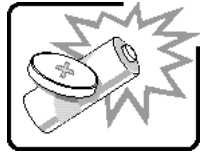
## English

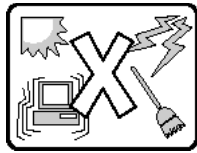
	<p>The power supply in this product contains no user-serviceable parts. Refer servicing only to qualified personnel.</p>
	<p>Do not attempt to modify or use the supplied AC power cord if it is not the exact type required. A product with more than one power supply will have a separate AC power cord for each supply.</p>
	<p>The power button on the system does not turn off system AC power. To remove AC power from the system, you must unplug each AC power cord from the wall outlet or power supply.</p> <p>The power cord(s) is considered the disconnect device to the main (AC) power. The socket outlet that the system plugs into shall be installed near the equipment and shall be easily accessible.</p>
	<p><b>SAFETY STEPS:</b> Whenever you remove the chassis covers to access the inside of the system, follow these steps:</p> <ol style="list-style-type: none"> <li>1. Turn off all peripheral devices connected to the system.</li> <li>2. Turn off the system by pressing the power button.</li> <li>3. Unplug all AC power cords from the system or from wall outlets.</li> <li>4. Label and disconnect all cables connected to I/O connectors or ports on the back of the system.</li> <li>5. Provide some electrostatic discharge (ESD) protection by wearing an antistatic wrist strap attached to chassis ground of the system-any unpainted metal surface-when handling components.</li> <li>6. Do not operate the system with the chassis covers removed.</li> </ol>
	<p>After you have completed the six SAFETY steps above, you can remove the system covers. To do this:</p> <ol style="list-style-type: none"> <li>1. Unlock and remove the padlock from the back of the system if a padlock has been installed.</li> <li>2. Remove and save all screws from the covers.</li> <li>3. Remove the cover(s).</li> </ol>

	<p>For proper cooling and airflow, always reinstall the chassis covers before turning on the system. Operating the system without the covers in place can damage system parts. To install the covers:</p> <ol style="list-style-type: none"> <li>1. Check first to make sure you have not left loose tools or parts inside the system.</li> <li>2. Check that cables, add-in boards, and other components are properly installed.</li> <li>3. Attach the covers to the chassis with the screws removed earlier, and tighten them firmly.</li> <li>4. Insert and lock the padlock to the system to prevent unauthorized access inside the system.</li> <li>5. Connect all external cables and the AC power cord(s) to the system.</li> </ol>
	<p>A microprocessor and heat sink may be hot if the system has been running. Also, there may be sharp pins and edges on some board and chassis parts. Contact should be made with care. Consider wearing protective gloves.</p>
	<p>Danger of explosion if the battery is incorrectly replaced. Replace only with the same or equivalent type recommended by the equipment manufacturer. Dispose of used batteries according to manufacturer's instructions.</p>
	<p>The system is designed to operate in a typical office environment. Choose a site that is:</p> <ul style="list-style-type: none"> <li>• Clean and free of airborne particles (other than normal room dust).</li> <li>• Well ventilated and away from sources of heat including direct sunlight.</li> <li>• Away from sources of vibration or physical shock.</li> <li>• Isolated from strong electromagnetic fields produced by electrical devices.</li> <li>• In regions that are susceptible to electrical storms, we recommend you plug your system into a surge suppresser and disconnect telecommunication lines to your modem during an electrical storm.</li> <li>• Provided with a properly grounded wall outlet.</li> <li>• Provided with sufficient space to access the power supply cord(s), because they serve as the product's main power disconnect.</li> </ul>

## Deutsch

	<p>Benutzer können am Netzgerät dieses Produkts keine Reparaturen vornehmen. Das Produkt enthält möglicherweise mehrere Netzgeräte. Wartungsarbeiten müssen von qualifizierten Technikern ausgeführt werden.</p>
	<p>Versuchen Sie nicht, das mitgelieferte Netzkabel zu ändern oder zu verwenden, wenn es sich nicht genau um den erforderlichen Typ handelt. Ein Produkt mit mehreren Netzgeräten hat für jedes Netzgerät ein eigenes Netzkabel.</p>
	<p>Der Wechselstrom des Systems wird durch den Ein-/Aus-Schalter für Gleichstrom nicht ausgeschaltet. Ziehen Sie jedes Wechselstrom-Netzkabel aus der Steckdose bzw. dem Netzgerät, um den Stromanschluß des Systems zu unterbrechen.</p>
	<p><b>SICHERHEISSMASSNAHMEN:</b> Immer wenn Sie die Gehäuseabdeckung abnehmen um an das Systeminnere zu gelangen, sollten Sie folgende Schritte beachten:</p> <ol style="list-style-type: none"> <li>1. Schalten Sie alle an Ihr System angeschlossenen Peripheriegeräte aus.</li> <li>2. Schalten Sie das System mit dem Hauptschalter aus.</li> <li>3. Ziehen Sie den Stromanschlußstecker Ihres Systems aus der Steckdose.</li> <li>4. Auf der Rückseite des Systems beschriften und ziehen Sie alle Anschlußkabel von den I/O Anschlüssen oder Ports ab.</li> <li>5. Tragen Sie ein geerdetes Antistatik Gelenkband, um elektrostatische Ladungen (ESD) über blanke Metallstellen bei der Handhabung der Komponenten zu vermeiden.</li> <li>6. Schalten Sie das System niemals ohne ordnungsgemäß montiertes Gehäuse ein.</li> </ol>

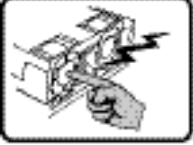
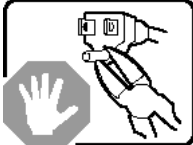


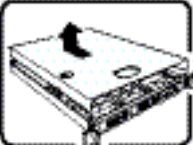
	<p><b>SICHERHEISSMASSNAHMEN:</b> Immer wenn Sie die Gehäuseabdeckung abnehmen um an das Systeminnere zu gelangen, sollten Sie folgende Schritte beachten:</p> <ol style="list-style-type: none"> <li>1. Schalten Sie alle an Ihr System angeschlossenen Peripheriegeräte aus.</li> <li>2. Schalten Sie das System mit dem Hauptschalter aus.</li> <li>3. Ziehen Sie den Stromanschlußstecker Ihres Systems aus der Steckdose.</li> <li>4. Auf der Rückseite des Systems beschrifteten und ziehen Sie alle Anschlußkabel von den I/O Anschlüssen oder Ports ab.</li> <li>5. Tragen Sie ein geerdetes Antistatik Gelenkband, um elektrostatische Ladungen (ESD) über blanke Metallstellen bei der Handhabung der Komponenten zu vermeiden.</li> <li>6. Schalten Sie das System niemals ohne ordnungsgemäß montiertes Gehäuse ein.</li> </ol>
	<p>Zur ordnungsgemäßen Kühlung und Lüftung muß die Gehäuseabdeckung immer wieder vor dem Einschalten installiert werden. Ein Betrieb des Systems ohne angebrachte Abdeckung kann Ihrem System oder Teile darin beschädigen. Um die Abdeckung wieder anzubringen:</p> <ol style="list-style-type: none"> <li>1. Vergewissern Sie sich, daß Sie keine Werkzeuge oder Teile im Innern des Systems zurückgelassen haben.</li> <li>2. Überprüfen Sie alle Kabel, Zusatzkarten und andere Komponenten auf ordnungsgemäßen Sitz und Installation.</li> <li>3. Bringen Sie die Abdeckungen wieder am Gehäuse an, indem Sie die zuvor gelösten Schrauben wieder anbringen. Ziehen Sie diese gut an.</li> <li>4. Bringen Sie die Verschlusseinrichtung (Padlock) wieder an und schließen Sie diese, um ein unerlaubtes Öffnen des Systems zu verhindern.</li> <li>5. Schließen Sie alle externen Kabel und den AC Stromanschlußstecker Ihres Systems wieder an.</li> </ol>
	<p>Der Mikroprozessor und der Kühler sind möglicherweise erhitzt, wenn das System in Betrieb ist. Außerdem können einige Platinen und Gehäuseteile scharfe Spitzen und Kanten aufweisen. Arbeiten an Platinen und Gehäuse sollten vorsichtig ausgeführt werden. Sie sollten Schutzhandschuhe tragen.</p>
	<p>Bei falschem Einsetzen einer neuen Batterie besteht Explosionsgefahr. Die Batterie darf nur durch denselben oder einen entsprechenden, vom Hersteller empfohlenen Batterietyp ersetzt werden. Entsorgen Sie verbrauchte Batterien den Anweisungen des Herstellers entsprechend.</p>



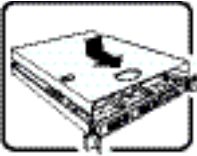
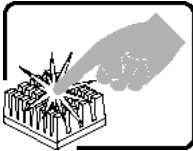
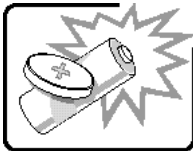
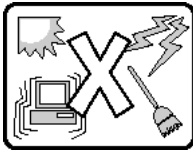
Das System wurde für den Betrieb in einer normalen Büroumgebung entwickelt. Der Standort sollte:

- "sauber und staubfrei sein (Hausstaub ausgenommen);
- "gut gelüftet und keinen Heizquellen ausgesetzt sein (einschließlich direkter Sonneneinstrahlung);
- "keinen Erschütterungen ausgesetzt sein;
- "keine starken, von elektrischen Geräten erzeugten elektromagnetischen Felder aufweisen;
- "in Regionen, in denen elektrische Stürme auftreten, mit einem Überspannungsschutzgerät verbunden sein; während eines elektrischen Sturms sollte keine Verbindung der Telekommunikationsleitungen mit dem Modem bestehen;
- "mit einer geerdeten Wechselstromsteckdose ausgerüstet sein;
- "über ausreichend Platz verfügen, um Zugang zu den Netzkabeln zu gewährleisten, da der Stromanschluß des Produkts hauptsächlich über die Kabel unterbrochen wird

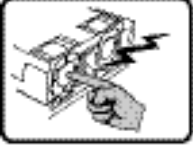
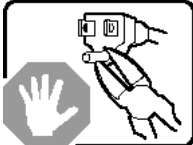


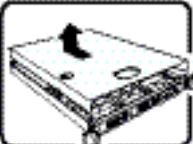
## Français

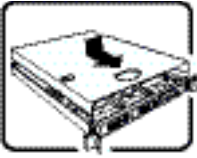
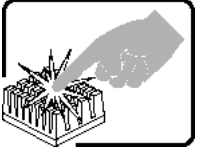
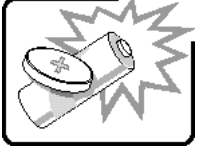
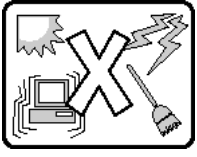
	<p>Le bloc d'alimentation de ce produit ne contient aucune pièce pouvant être réparée par l'utilisateur. Ce produit peut contenir plus d'un bloc d'alimentation. Veuillez contacter un technicien qualifié en cas de problème.</p>
	<p>Ne pas essayer d'utiliser ni modifier le câble d'alimentation CA fourni, s'il ne correspond pas exactement au type requis. Le nombre de câbles d'alimentation CA fournis correspond au nombre de blocs d'alimentation du produit</p>
	<p>Notez que le commutateur CC de mise sous tension /hors tension du panneau avant n'éteint pas l'alimentation CA du système. Pour mettre le système hors tension, vous devez débrancher chaque câble d'alimentation de sa prise.</p>
	<p><b>CONSIGNES DE SÉCURITÉ</b> -Lorsque vous ouvrez le boîtier pour accéder à l'intérieur du système, suivez les consignes suivantes:</p> <ol style="list-style-type: none"> <li>1. Mettez hors tension tous les périphériques connectés au système.</li> <li>2. Mettez le système hors tension en mettant l'interrupteur général en position OFF (bouton-poussoir).</li> <li>3. Débranchez tous les cordons d'alimentation c.a. du système et des prises murales.</li> <li>4. Identifiez et débranchez tous les câbles reliés aux connecteurs d'E-S ou aux accès derrière le système.</li> <li>5. Pour prévenir les décharges électrostatiques lorsque vous touchez aux composants, portez une bande antistatique pour poignet et reliez-la à la masse du système (toute surface métallique non peinte du boîtier).</li> <li>6. Ne faites pas fonctionner le système tandis que le boîtier est ouvert.</li> </ol>
	<p>Une fois TOUTES les étapes précédentes accomplies, vous pouvez retirer les panneaux du système. Procédez comme suit:</p> <ol style="list-style-type: none"> <li>1. Si un cadenas a été installé sur à l'arrière du système, déverrouillez-le et retirez-le.</li> <li>2. Retirez toutes les vis des panneaux et mettez-les dans un endroit sûr.</li> <li>3. Retirez les panneaux.</li> </ol>



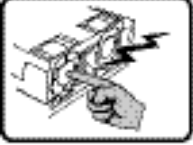
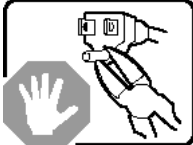

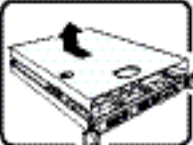
	<p>Afin de permettre le refroidissement et l'aération du système, réinstallez toujours les panneaux du boîtier avant de mettre le système sous tension. Le fonctionnement du système en l'absence des panneaux risque d'endommager ses pièces. Pour installer les panneaux, procédez comme suit:</p> <ol style="list-style-type: none"> <li>1. Assurez-vous de ne pas avoir oublié d'outils ou de pièces démontées dans le système.</li> <li>2. Assurez-vous que les câbles, les cartes d'extension et les autres composants sont bien installés.</li> <li>3. Revissez solidement les panneaux du boîtier avec les vis retirées plus tôt.</li> <li>4. Remettez le cadenas en place et verrouillez-le afin de prévenir tout accès non autorisé à l'intérieur du système.</li> <li>5. Rebranchez tous les cordons d'alimentation c. a. et câbles externes au système.</li> </ol>
	<p>Le microprocesseur et le dissipateur de chaleur peuvent être chauds si le système a été sous tension. Faites également attention aux broches aiguës des cartes et aux bords tranchants du capot. Nous vous recommandons l'usage de gants de protection.</p>
	<p>Danger d'explosion si la batterie n'est pas remontée correctement. Remplacer uniquement avec une batterie du même type ou d'un type équivalent recommandé par le fabricant. Disposez des piles usées selon les instructions du fabricant.</p>
	<p>Le système a été conçu pour fonctionner dans un cadre de travail normal. L'emplacement choisi doit être:</p> <ul style="list-style-type: none"> <li>• "Propre et dépourvu de poussière en suspension (sauf la poussière normale).</li> <li>• "Bien aéré et loin des sources de chaleur, y compris du soleil direct.</li> <li>• "A l'abri des chocs et des sources de vibrations.</li> <li>• "Isolé de forts champs électromagnétiques géenérés par des appareils électriques.</li> <li>• "Dans les régions sujettes aux orages magnétiques il est recomandé de brancher votre système à un supresseur de surtension, et de débrancher toutes les lignes de télécommunications de votre modem durant un orage.</li> <li>• "Muni d'une prise murale correctement mise à la terre.</li> <li>• "Suffisamment spacieux pour vous permettre d'accéder aux câbles d'alimentation (ceux-ci étant le seul moyen de mettre le système hors tension).</li> </ul>

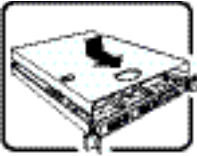
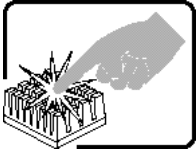
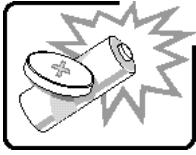
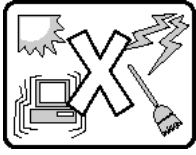
## Español

	<p>El usuario debe abstenerse de manipular los componentes de la fuente de alimentación de este producto, cuya reparación debe dejarse exclusivamente en manos de personal técnico especializado. Puede que este producto disponga de más de una fuente de alimentación</p>
	<p>No intente modificar ni usar el cable de alimentación de corriente alterna, si no corresponde exactamente con el tipo requerido. El número de cables suministrados se corresponden con el número de fuentes de alimentación de corriente alterna que tenga el producto</p>
	<p>Nótese que el interruptor activado/desactivado en el panel frontal no desconecta la corriente alterna del sistema. Para desconectarla, deberá desenchufar todos los cables de corriente alterna de la pared o desconectar la fuente de alimentación.</p>
	<p><b>INSTRUCCIONES DE SEGURIDAD:</b> Cuando extraiga la tapa del chasis para acceder al interior del sistema, siga las siguientes instrucciones:</p> <ol style="list-style-type: none"> <li>1. Apague todos los dispositivos periféricos conectados al sistema.</li> <li>2. Apague el sistema presionando el interruptor encendido/apagado.</li> <li>3. Desconecte todos los cables de alimentación CA del sistema o de las tomas de corriente alterna.</li> <li>4. Identifique y desconecte todos los cables enchufados a los conectores E/S o a los puertos situados en la parte posterior del sistema.</li> <li>5. Cuando manipule los componentes, es importante protegerse contra la descarga electrostática (ESD). Puede hacerlo si utiliza una muñequera antiestática sujeta a la toma de tierra del chasis - o a cualquier tipo de superficie de metal sin pintar.</li> <li>6. No ponga en marcha el sistema si se han extraído las tapas del chasis.</li> </ol>
	<p>Después de completar las seis instrucciones de SEGURIDAD mencionadas, ya puede extraer las tapas del sistema. Para ello:</p> <ol style="list-style-type: none"> <li>1. Desbloquee y extraiga el bloqueo de seguridad de la parte posterior del sistema, si se ha instalado uno.</li> <li>2. Extraiga y guarde todos los tornillos de las tapas. Extraiga las tapas.</li> </ol>

	<p>Para obtener un enfriamiento y un flujo de aire adecuados, reinstale siempre las tapas del chasis antes de poner en marcha el sistema. Si pone en funcionamiento el sistema sin las tapas bien colocadas puede dañar los componentes del sistema. Para instalar las tapas:</p> <ol style="list-style-type: none"> <li>1. Asegúrese primero de no haber dejado herramientas o componentes sueltos dentro del sistema.</li> <li>2. Compruebe que los cables, las placas adicionales y otros componentes se hayan instalado correctamente.</li> <li>3. Incorpore las tapas al chasis mediante los tornillos extraídos anteriormente, tensándolos firmemente.</li> <li>4. Inserte el bloqueo de seguridad en el sistema y bloquéelo para impedir que pueda accederse al mismo sin autorización.</li> <li>5. Conecte todos los cables externos y los cables de alimentación CA al sistema.</li> </ol>
	<p>Si el sistema ha estado en funcionamiento, el microprocesador y el disipador de calor pueden estar aún calientes. También conviene tener en cuenta que en el chasis o en el tablero puede haber piezas cortantes o punzantes. Por ello, se recomienda precaución y el uso de guantes protectores.</p>
	<p>Existe peligro de explosión si la pila no se cambia de forma adecuada. Utilice solamente pilas iguales o del mismo tipo que las recomendadas por el fabricante del equipo. Para deshacerse de las pilas usadas, siga igualmente las instrucciones del fabricante.</p>
	<p>El sistema está diseñado para funcionar en un entorno de trabajo normal. escoja un lugar:</p> <ul style="list-style-type: none"> <li>• "Limpio y libre de partículas en suspensión (salvo el polvo normal).</li> <li>• "Bien ventilado y alejado de fuentes de calor, incluida la luz solar directa.</li> <li>• "Alejado de fuentes de vibración.</li> <li>• "Aislado de campos electromagnéticos fuertes producidos por dispositivos eléctricos.</li> <li>• "En regiones con frecuentes tormentas eléctricas, se recomienda conectar su sistema a un eliminador de sobrevoltage y desconectar el módem de las líneas de telecomunicación durante las tormentas.</li> <li>• "Provisto de una toma de tierra correctamente instalada.</li> <li>• "Provisto de espacio suficiente como para acceder a los cables de alimentación, ya que éstos hacen de medio principal de desconexión del sistema.</li> </ul>

## Italiano

	<p>Rivolgersi ad un tecnico specializzato per la riparazione dei componenti dell'alimentazione di questo prodotto. È possibile che il prodotto disponga di più fonti di alimentazione.</p>
	<p>Non modificare o utilizzare il cavo di alimentazione in c.a. fornito dal produttore, se non corrisponde esattamente al tipo richiesto. Ad ogni fonte di alimentazione corrisponde un cavo di alimentazione in c.a. separato</p>
	<p>L'interruttore attivato/disattivato nel pannello anteriore non interrompe l'alimentazione in c.a. del sistema. Per interromperla, è necessario scollegare tutti i cavi di alimentazione in c.a. dalle prese a muro o dall'alimentazione di corrente.</p>
	<p><b>PASSI DI SICUREZZA:</b> Qualora si rimuovano le coperture del telaio per accedere all'interno del sistema, seguire i seguenti passi:</p> <ol style="list-style-type: none"> <li>1. Spegner tutti i dispositivi periferici collegati al sistema.</li> <li>2. Spegner il sistema, usando il pulsante spento/acceso dell'interruttore del sistema.</li> <li>3. Togliere tutte le spine dei cavi del sistema dalle prese elettriche.</li> <li>4. Identificare e sconnettere tutti i cavi attaccati ai collegamenti I/O od alle prese installate sul retro del sistema.</li> <li>5. Qualora si tocchino i componenti, proteggersi dallo scarico elettrostatico (SES), portando un cinghia anti-statica da polso che è attaccata alla presa a terra del telaio del sistema - qualsiasi superficie non dipinta - .</li> <li>6. Non far operare il sistema quando il telaio è senza le coperture.</li> </ol>
	<p>Dopo aver seguito i sei passi di SICUREZZA sopracitati, togliere le coperture del telaio del sistema come segue:</p> <ol style="list-style-type: none"> <li>1. Aprire e rimuovere il lucchetto dal retro del sistema qualora ve ne fosse uno installato.</li> <li>2. Togliere e mettere in un posto sicuro tutte le viti delle coperture.</li> <li>3. Togliere le coperture.</li> </ol>

	<p>Per il giusto flusso dell'aria e raffreddamento del sistema, rimettere sempre le coperture del telaio prima di riaccendere il sistema. Operare il sistema senza le coperture al loro proprio posto potrebbe danneggiare i componenti del sistema. Per rimettere le coperture del telaio:</p> <ol style="list-style-type: none"> <li>1. Controllare prima che non si siano lasciati degli attrezzi o dei componenti dentro il sistema.</li> <li>2. Controllare che i cavi, dei supporti aggiuntivi ed altri componenti siano stati installati appropriatamente.</li> <li>3. Attaccare le coperture al telaio con le viti tolte in precedenza e avvitarle strettamente.</li> <li>4. Inserire e chiudere a chiave il lucchetto sul retro del sistema per impedire l'accesso non autorizzato al sistema.</li> <li>5. Ricollegare tutti i cavi esterni e le prolunghie AC del sistema.</li> </ol>
	<p>Se il sistema è stato a lungo in funzione, il microprocessore e il dissipatore di calore potrebbero essere surriscaldati. Fare attenzione alla presenza di piedini appuntiti e parti taglienti sulle schede e sul telaio. È consigliabile l'uso di guanti di protezione.</p>
	<p>Esiste il pericolo di un'esplosione se la pila non viene sostituita in modo corretto. Utilizzare solo pile uguali o di tipo equivalente a quelle consigliate dal produttore. Per disfarsi delle pile usate, seguire le istruzioni del produttore.</p>
	<p>Il sistema è progettato per funzionare in un ambiente di lavoro tipo. Scegliere una postazione che sia:</p> <ul style="list-style-type: none"> <li>• "Pulita e libera da particelle in sospensione (a parte la normale polvere presente nell'ambiente).</li> <li>• "Ben ventilata e lontana da fonti di calore, compresa la luce solare diretta.</li> <li>• "Al riparo da urti e lontana da fonti di vibrazione.</li> <li>• "Isolata dai forti campi magnetici prodotti da dispositivi elettrici.</li> <li>• "In aree soggette a temporali, è consigliabile collegare il sistema ad un limitatore di corrente. In caso di temporali, scollegare le linee di comunicazione dal modem.</li> <li>• "Dotata di una presa a muro correttamente installata.</li> <li>• "Dotata di spazio sufficiente ad accedere ai cavi di alimentazione, i quali rappresentano il mezzo principale di scollegamento del sistema.</li> </ul>



# I Warranty

---

## Limited Warranty for Intel® Chassis Subassembly Products

Intel warrants that the Products (defined herein as the Intel® chassis subassembly and all of its various components and software delivered with or as part of the Products) to be delivered hereunder, if properly used and installed, will be free from defects in material and workmanship and will substantially conform to Intel's publicly available specifications for a period of three (3) years after the date the Product was purchased from an Intel authorized distributor. Software of any kind delivered with or as part of products is expressly provided "as is" unless specifically provided for otherwise in any software license accompanying the software.

If any Product furnished by Intel which is the subject of this Limited Warranty fails during the warranty period for reasons covered by this Limited Warranty, Intel, at its option, will:

- REPAIR the Product by means of hardware and/or software; OR
- REPLACE the Product with another Product; OR
- REFUND the then-current value of the Product if Intel is unable to repair or replace the Product.

If such Product is defective, transportation charges for the return of Product to buyer within the USA will be paid by Intel. For all other locations, the warranty excludes all costs of shipping, customs clearance, and other related charges. Intel will have a reasonable time to make repairs or to replace Product or to refund the then-current value of the Product.

In no event will Intel be liable for any other costs associated with the replacement or repair of Product, including labor, installation or other costs incurred by buyer and in particular, any costs relating to the removal or replacement of any product soldered or otherwise permanently affixed to any printed circuit board.

This Limited Warranty, and any implied warranties that may exist under state law, apply only to the original purchaser of the Product.

## Extent of Limited Warranty

Intel does not warrant that Products to be delivered hereunder, whether delivered stand-alone or integrated with other Products, including without limitation semiconductor components, will be free from design defects or errors known as "errata." Current characterized errata are available upon request.

This Limited Warranty does not cover damages due to external causes, including accident, problems with electrical power, usage not in accordance with product instructions, misuse, neglect, alteration, repair, improper installation, or improper testing.

## Warranty Limitations and Exclusions

These warranties replace all other warranties, expressed or implied including, but not limited to, the implied warranties of merchantability and fitness for a particular purpose. Intel makes no expressed warranties beyond those stated here. Intel disclaims all other warranties, expressed or implied including, without limitation, implied warranties of merchantability and fitness for a particular purpose. Some jurisdictions do not allow the exclusion of implied warranties, so this limitation may not apply.

All expressed and implied warranties are limited in duration to the limited warranty period. No warranties apply after that period. Some jurisdictions do not allow limitations on how long an implied warranty lasts, so this limitation may not apply to you.

## Limitations of Liability

Intel's responsibility under this, or any other warranty, implied or expressed, is limited to repair, replacement, or refund, as set forth above. These remedies are the sole and exclusive remedies for any breach of warranty. Intel is not responsible for direct, special, incidental, or consequential damages resulting from any breach of warranty under another legal theory including, but not limited to, lost profits, downtime, goodwill, damage to or replacement of equipment and property, and any costs of recovering, reprogramming, or reproducing any program or data stored in or used with a system containing this product. Some jurisdictions do not allow the exclusion or limitation of incidental or consequential damages, so the above limitations or exclusions may not apply to you.

This limited warranty gives you specific legal rights, and you may also have other rights that vary from jurisdiction to jurisdiction.

Any and all disputes arising under or related to this Limited Warranty shall be adjudicated in the following forums and governed by the following laws: for the United States of America, Canada, North America, and South America, the forum shall be Santa Clara, California, USA, and the applicable law shall be that of the State of California, USA; for the Asia Pacific region, the forum shall be Singapore and the applicable law shall be that of Singapore; for Europe and the rest of the world, the forum shall be London and the applicable law shall be that of the United Kingdom.

In the event of any conflict between the English language version and any other translated version(s) of this Limited Warranty, the English language version shall control.

## How to Obtain Warranty Service

To obtain warranty service for this Product, you may contact Intel or your authorized distributor.

- North America and Latin America To obtain warranty repair for the product, please go to the following Web site to obtain instructions: <http://support.intel.com/support/motherboards/draform.htm>
- In Europe and in Asia Contact your original authorized distributor for warranty service.



Any replacement Product is warranted under this written warranty and is subject to the same limitations and exclusions for the remainder of the original warranty period.

## Telephone Support

If you cannot find the information you need on Intel's World Wide Web site (<http://www.intel.com/>), call your local distributor or an Intel Customer Support representative. See “Getting Help” for telephone numbers.

## Returning a Defective Product

Before returning any product, call your authorized dealer/distribution authority.

*Warranty*