

Intel[®] PRO/Wireless 2011 Site Survey

System Administrators Guide

July 2000

Copyright

Copyright © 2000, Intel Corporation. All rights reserved.

Intel Corporation, 5200 N.E. Elam Young Parkway, Hillsboro, OR 97124-6497

This manual as well as the software described in it is furnished under license and may only be used or copied in accordance with the terms of the license. The information in this manual is furnished for informational use only, is subject to change without notice, and should not be construed as a commitment by Intel Corporation. Intel Corporation assumes no responsibility or liability for any errors or inaccuracies that may appear in this document or any software that may be provided in association with this document.

Except as permitted by such license, no part of this document may be reproduced, stored in a retrieval system, or transmitted in any form or by any means without the express written consent of Intel Corporation.

* Other product and corporate names may be trademarks of other companies and are used only for explanation and to the owners' benefit, without intent to infringe.

Patents

This product is covered by one or more of the following U.S. and foreign Patents:

U.S. Patent No.

| | | | | | | | | | |
|------------|------------|------------|------------|------------|------------|------------|------------|------------|------------|
| 4,360,798; | 4,369,361; | 4,387,297; | 4,460,120; | 4,496,831; | 4,593,186; | 4,603,262; | 4,607,156; | 4,652,750; | 4,673,805; |
| 4,736,095; | 4,758,717; | 4,816,660; | 4,845,350; | 4,896,026; | 4,897,532; | 4,923,281; | 4,933,538; | 4,992,717; | 5,015,833; |
| 5,017,765; | 5,021,641; | 5,029,183; | 5,047,617; | 5,103,461; | 5,113,445; | 5,130,520; | 5,140,144; | 5,142,550; | 5,149,950; |
| 5,157,687; | 5,168,148; | 5,168,149; | 5,180,904; | 5,216,232; | 5,229,591; | 5,230,088; | 5,235,167; | 5,243,655; | 5,247,162; |
| 5,250,791; | 5,250,792; | 5,260,553; | 5,262,627; | 5,262,628; | 5,266,787; | 5,278,398; | 5,280,162; | 5,280,163; | 5,280,164; |
| 5,280,498; | 5,304,786; | 5,304,788; | 5,306,900; | 5,321,246; | 5,324,924; | 5,337,361; | 5,367,151; | 5,373,148; | 5,378,882; |
| 5,396,053; | 5,396,055; | 5,399,846; | 5,408,081; | 5,410,139; | 5,410,140; | 5,412,198; | 5,418,812; | 5,420,411; | 5,436,440; |
| 5,444,231; | 5,449,891; | 5,449,893; | 5,468,949; | 5,471,042; | 5,478,998; | 5,479,000; | 5,479,002; | 5,479,441; | 5,504,322; |
| 5,519,577; | 5,528,621; | 5,532,469; | 5,543,610; | 5,545,889; | 5,552,592; | 5,557,093; | 5,578,810; | 5,581,070; | 5,589,679; |
| 5,589,680; | 5,608,202; | 5,612,531; | 5,619,028; | 5,627,359; | 5,637,852; | 5,664,229; | 5,668,803; | 5,675,139; | 5,693,929; |
| 5,698,835; | 5,705,800; | 5,714,746; | 5,723,851; | 5,734,152; | 5,734,153; | 5,742,043; | 5,745,794; | 5,754,587; | 5,762,516; |
| 5,763,863; | 5,767,500; | 5,789,728; | 5,789,731; | 5,808,287; | 5,811,785; | 5,811,787; | 5,815,811; | 5,821,519; | 5,821,520; |
| 5,823,812; | 5,828,050; | 5,850,078; | 5,861,615; | 5,874,720; | 5,875,415; | 5,900,617; | 5,902,989; | 5,907,146; | 5,912,450; |
| 5,914,478; | 5,917,173; | 5,920,059; | 5,923,025; | 5,929,420; | 5,945,658; | 5,945,659; | 5,946,194; | 5,959,285; | D305,885; |
| D341,584; | D344,501; | D359,483; | D362,453; | D363,700; | D363,918; | D370,478; | D383,124; | D391,250; | D405,077; |
| D406,581; | D414,171; | D414,172 | | | | | | | |

Invention No. 55,358; 62,539; 69,060; 69,187 (Taiwan); No. 1,601,796; 1,907,875; 1,955,269 (Japan); European Patent 367,299; 414,281; 367,300; 367,298; UK 2,072,832; France 81/03938; Italy 1,138,713

A28557-01
Revision A

About This Document

Reference Documents

This reference guide refers to the following documents:

| Part Number | Document Title |
|-------------|---|
| A28551-01 | Intel® PRO/Wireless 2011 Access Point Product Reference Guide |
| A28553-01 | Intel® PRO/Wireless 2011 LAN Utilities User Guide |
| A28555-01 | Intel® PRO/Wireless 2011 LAN PC Card Product Reference Guide |

Conventions

Keystrokes are indicated as follows:

| | |
|---------------|---|
| ENTER | identifies a key. |
| FUNC, CTRL, C | identifies a key sequence. Press and release each key in turn. |
| Press A+B | press the indicated keys simultaneously. |
| Hold A+B | press and hold the indicated keys while performing or waiting for another function. Used in combination with another keystroke. |

Typeface conventions used include:

| | |
|-----------------|--|
| <angles> | indicates mandatory parameters in a given syntax. |
| [brackets] | for command line, indicates available parameters; in configuration files brackets act as separators for options. |
| GUI Screen text | indicates the name of a control in a GUI-based application. |
| <i>Italics</i> | indicates the first time a term is used, a book title, variables, and menu titles. |
| 'single quotes' | indicates the exact setting for a parameter. |
| Screen | indicates monitor screen dialog. Also indicates user input. A screen is the hardware device on which data appears. A display is data arranged on a screen. |
| Terminal | indicates text shown on a radio terminal screen. |

URL indicates Uniform Resource Locator.

This document uses the following for certain conditions or types of information:



Indicates tips or special requirements.



Indicates conditions that can cause equipment damage or data loss.



Indicates a potentially dangerous condition or procedure that only Intel-trained personnel should attempt to correct or perform.

Contents

| | | |
|------------------|---|-----------|
| Chapter 1 | Preparing for an Intel Site Survey | 1 |
| 1.1 | Inspecting the Survey Area | 2 |
| 1.1.1 | Environmental Radio Coverage Considerations | 3 |
| 1.1.2 | Channel Interference Considerations | 4 |
| 1.2 | Antenna Placement Considerations | 5 |
| 1.2.1 | Diversity Reception | 7 |
| 1.2.2 | Site Electrical Considerations | 7 |
| 1.3 | Requesting an Intel® PRO/Wireless 2011 LAN Site Survey | 8 |
| 1.3.1 | Scheduling the Site Survey | 9 |
| Chapter 2 | Using the Site Survey Utility to Conduct a Site Survey | 11 |
| 2.1 | Installing the Intel® PRO/Wireless 2011 LAN Site Survey Utility..... | 12 |
| 2.1.1 | Installing the Site Survey Utility from a CDROM | 12 |
| 2.1.2 | Copying the Site Survey Utility from the Intel Web Site to a Desktop Computer | 12 |
| 2.2 | Creating a Trial Intel® PRO/Wireless 2011 LAN | 13 |
| 2.3 | Starting the Intel® PRO/Wireless 2011 LAN Site Survey Utility..... | 15 |
| 2.4 | Navigating the Site Survey Utility File Menu | 17 |
| 2.4.1 | Creating a New Site Survey..... | 18 |
| 2.4.2 | Selecting an Existing Site Survey | 18 |
| 2.4.3 | Defining a New Site Survey Area | 19 |
| 2.4.4 | Save/Save As | 19 |
| 2.4.5 | Importing a Site Survey..... | 20 |
| 2.4.6 | Working With Reports | 20 |
| 2.4.7 | Displaying Recent Site Surveys..... | 21 |
| 2.5 | Navigating the Edit Menu | 21 |
| 2.5.1 | Editing Existing Site Survey Information | 22 |
| 2.5.2 | Editing the Properties of an Existing Site Survey Area | 23 |

| | | |
|-------------------|--|------------|
| 2.5.3 | Editing the Default Settings Property Pages | 24 |
| 2.6 | Navigating the View Menu | 29 |
| 2.6.1 | Viewing Adapter Info..... | 30 |
| 2.6.2 | Viewing Site Survey Area Info..... | 31 |
| 2.6.3 | Viewing Access Point Info..... | 32 |
| 2.6.4 | Viewing Mobile Unit Noise Info | 34 |
| 2.6.5 | Viewing Mobile Unit Signal Quality Info | 36 |
| 2.6.6 | Generating the Site Survey Report | 37 |
| 2.7 | Navigating the Area Menu..... | 38 |
| 2.7.1 | Creating a New Survey Area..... | 39 |
| 2.7.2 | Selecting and Editing an Existing Survey Area | 40 |
| 2.7.3 | Clearing the Text File Log for an Open Survey Area | 41 |
| 2.7.4 | Editing the Note File for an Open Survey Area..... | 41 |
| 2.7.5 | Running ICMP Tests | 41 |
| 2.7.6 | Running Throughput Tests | 46 |
| Chapter 3 | Conducting a Size Specific Site Survey | 49 |
| 3.1 | Conducting a Survey for a Small Area | 49 |
| 3.2 | Conducting a Survey for a Medium Sized Area | 50 |
| 3.3 | Conducting a Survey for a Large Area | 52 |
| Appendix A | Intel® PRO/Wireless 2011 LAN Overview | A-1 |
| A.1 | Radio Basics..... | A-2 |
| A.1.1 | Network Topology | A-2 |
| A.1.2 | Cellular Coverage | A-4 |
| A.2 | Access Point (AP)..... | A-6 |
| A.3 | Advanced Radio Theory..... | A-7 |
| A.3.1 | MAC Layer Bridging..... | A-8 |
| A.3.2 | DHCP Support..... | A-10 |
| A.3.3 | Media Types..... | A-11 |
| A.3.4 | Bridging Support..... | A-12 |
| A.3.5 | Direct-Sequence Spread Spectrum | A-16 |

| | |
|--|----------------|
| A.3.6 Frequency-Hopping Spread Spectrum..... | A-17 |
| A.3.7 MU Association Process..... | A-19 |
| A.3.8 Mobile IP..... | A-21 |
| A.3.9 Supporting CAM and PSP Stations..... | A-23 |
| A.3.10 Data Encryption..... | A-25 |
| A.3.11 HTTP, HTML Web Server Support..... | A-26 |
| A.3.12 Management Options..... | A-27 |
| Appendix B Customer Support..... | B-1 |
| B.1 Intel Automated Customer Support..... | B-1 |
| B.2 Software License Agreement..... | B-2 |
| B.3 Limited Lifetime Hardware Warranty..... | B-5 |
| Appendix C Regulatory Compliance..... | C-1 |
| Index..... | Index-1 |

Chapter 1 **Preparing for an Intel Site Survey**

Installing an Intel[®] PRO/Wireless 2011 LAN begins with conducting a site survey. A site survey involves using the Site Survey utility to determine the physical requirements for a site-specific Intel[®] PRO/Wireless 2011 LAN. A site survey analyzes the installation environment and provides users with recommendations for equipment and placement.

Use the Site Survey utility to determine the placement of access points and antennas, as well as the number of devices necessary to provide optimal service. The facility can be a warehouse, manufacturing plant, office building or retail store.



Only the Intel site survey team or other qualified site survey technicians should use the Intel[®] PRO/Wireless 2011 LAN Site Survey utility

In the installation of an Intel[®] PRO/Wireless 2011 LAN, complete radio coverage could require multiple antennas. If the facility is small, or the coverage area is free from physical obstructions, one access point and antenna could be sufficient. However, a dual-antenna access point could be required to provide additional diversity if performance and signal reception issues exist.

If unfamiliar with the Intel[®] PRO/Wireless 2011 LAN infrastructure and the components that comprise it, refer to Appendix A “Intel[®] PRO/Wireless 2011 LAN Overview” for an overview of Intel[®] PRO/Wireless 2011 LAN technology.

1.1 Inspecting the Survey Area

During the planning stages of the site survey, a representative from the site survey team visits the proposed radio coverage site. As a standard practice in the site survey consultation, the representative gathers facility drawings and completes a Site Survey Requirements document and a site survey questionnaire. The representative documents the wiring used within the facility (10BaseT, 10Base2, fiber optic) and assesses its applicability to Intel® PRO/Wireless 2011 LAN components.

Several trial installation areas should be selected. The site survey team analyzes each proposed installation area to document radio transmission constraints and to develop preliminary access point placement alternatives to be tested during the actual site survey. The findings from the initial site inspection should be documented in a Site Survey Request Form and serve as the outline of the site survey.

The following variables should also be considered in the site survey requirements definition:

- RF systems already in use
- availability of lifts for mounting access points
- location of host system(s)
- available AC power
- interfering metal fire breaks and wall structures
- availability of customer technical personnel to answer questions during the survey
- doorways and passages causing RF propagation.

The completion of the RF Site Survey Requirements document is a coordinated effort between the site survey team and the customer management team.

The RF Site Survey Requirements document does not identify potential installation constraints within the customer site, nor does it recommend access point and antenna placement location. The RF Site Survey Requirements document represents a preliminary overview of the customer site used as a baseline for refining site survey requirements.

1.1.1 Environmental Radio Coverage Considerations

The site survey team selects trial component installation areas away from transformers, heavy-duty motors, fluorescent lights, microwave ovens, refrigerators and other industrial equipment. Areas with excessive moisture, heat and dust are inappropriate for staging a wireless network.

Signal loss can occur when metal, concrete, walls or floors block access point transmission areas. Access point antennas are trial-mounted in open areas or added to an existing access point to boost the Intel® PRO/Wireless 2011 LAN coverage area.

The positioning of an access point depends on the floor plan of the site. The site survey team makes access point and antenna placement recommendations based on the following installation site variables:

- outdoor or indoor installation site
- large or small proposed radio coverage area
- wide or narrow proposed coverage area
- open coverage area or area with documented obstructions.

General Guidelines

Site surveys for direct-sequence spread spectrum devices require experimentation with different antennas at various angles. Placing a directional antenna in a vertical position can often minimize multi-path problems in a direct-sequence environment.

In an indoor environment the range at 11 Mbps is about 60 feet, with some data packets transmitting at 5.5 Mbps. The range at 5.5 Mbps is between 100 - 120 feet, with some data packets transmitting at 2 Mbps. In an open air environment, the range is between 600 and 1200 feet. These measurements were obtained with antenna diversity enabled.



Do not locate access points near corners, against walls, against metal walls or inside plenums.

1.1.2 Channel Interference Considerations

Intel® PRO/Wireless 2011 LAN access points require careful survey area testing to ensure radio transmissions do not overlap. If necessary, adjacent access points require omnidirectional and directional antennas to optimize radio coverage in conflicting coverage areas and neighboring cells with the same direct-sequence channel.

1.2 Antenna Placement Considerations

Radio coverage requirements relate directly to installation site constraints. With an omnidirectional antenna, the radio range of the access point could have a radius up to 1000 feet (303 meters) in open areas. However, in office or retail environments, obstructions can reduce the coverage to a radius of 180 to 250 feet (54 to 76 meters). Use a directional antenna for sites that require longer distances over relatively narrow areas. The coverage area is also referred to as a cell.

An omnidirectional antenna transmits and receives radio waves in all directions. The coverage area is circular with the antenna at the center. Omnidirectional antennas are also referred to as whip or low-profile antennas.

Directional antennas transmit and receive radio waves off the front of the antenna. The power behind and to the sides of the antenna is reduced. The coverage area is oval with the antenna at one of the narrow ends. Typical directional antenna beam width angles are from 90°, (somewhat directional), to as little as 20°(very directional). A directional antenna directs power to concentrate the coverage pattern in a particular direction. The antenna direction is specified by the angle of the coverage pattern called the beam width.

The decibel (dB) represents the unit of comparative power for assessing radio signal strength. For Intel® PRO/Wireless 2011 LAN antennas, addition and subtraction can calculate total dB loss. The abbreviation dBm is the decibel referenced to 1 milliwatt (mW).

Mathematically:

$$\text{dB} = 10 \text{ LOG } P_r \text{ where } P_r \text{ is the power ratio } (P_1/P_2)$$

when calculated against 1 mW then:

$$\text{dBm} = 10 \text{ LOG } P/.001\text{W}$$

Example:

$$P = 2W, \text{ then } Pr = 2W/.001W = 2000$$

$$\text{dBm} = 10 \times \text{LOG } 2000 = 10 \times 3.3 = 33$$

therefore, a 2W transmitter equates to 33 dBm.

To convert dBm back to a power level the inverse function is used that is:

$$P_{mW} = 10^{(\text{dBm}/10)}$$

For directional antennas, signal strength (gain) can be increased by diverting power from the non-coverage areas and redirecting it into the area where coverage is required.

When directional antenna power is concentrated, RF coverage increases within the beam width. The increase in RF coverage within the beam width is called antenna gain, and is measured in dB. A good guideline is a 2.5% increase in range for each 1 dB increase in antenna gain for indoor sites, and a 5% increase in range for each 1 dB increase in antenna gain for unobstructed outdoor sites. Actual results vary depending on site obstructions.

Directional antennas are recommended where the coverage area is confined to an area such as a hallway or corridor. Intel recommends omnidirectional antennas in areas where the coverage area is in an open area with little interference.

The final location of access point antennas is critical to the successful operation of the system. When conducting the survey, consider the exact conditions in the installation area. These conditions include all losses due to cabling and connectors.

1.2.1 Diversity Reception

Diversity reception is the use of two antennas attached to a single access point. A second antenna can improve radio reception. The second antenna is attached to the AP SECONDARY ANTENNA connector and is used only for receiving radio signals. The primary antenna is used for both transmitting and receiving.

The principle behind diversity is to overcome interference or fading by using the signal with the strongest reception.

1.2.2 Site Electrical Considerations

Intel® PRO/Wireless 2011 LAN access points draw power from wall outlets. Access point performance is subject to degradation due to inherent or random electrical problems or site-specific disturbances.

The following access point electrical installation alternatives are listed from optimal for an installation area to preferred for that area:

1. isolated ground circuit with an online, uninterruptible power supply (UPS) that also acts as a filter and surge suppressor
2. isolated ground circuit with a surge suppressor
3. dedicated circuit with a UPS
4. dedicated circuit with a surge suppressor
5. nondedicated circuit with a UPS
6. nondedicated circuit with a surge suppressor

Intel recommends items one through four when using a Network Controller Unit. Deviation from one of these four items can cause data loss and serious transmissions problems.

Intel does not recommend configuration items five and six due to the nature of a nondedicated circuit. A nondedicated circuit contains open receptacles and the load and type of use cannot be predicted at the time of installation.



Ensure the availability of power to an access point 24 hours a day. Intel recommends access point power never be provided from an Energy Management System.

If it is necessary to use a nondedicated circuit, Intel recommends that the circuit not support:

- hard wired devices
- devices with components intended or known to produce heat such as space heaters, laser printers, heat guns and soldering irons
- single device drawing more than 20% of the rated value of the circuit
- devices drawing more than 60% of the rated circuit value.

1.3 Requesting an Intel[®] PRO/Wireless 2011 LAN Site Survey

Once the customer has been consulted, their needs identified, environmental antenna requirements considered, site electrical constraints identified and several trial installation sites selected, a survey team representative completes the Site Survey Request Form.

The Site Survey Request Form contains detailed information about the customer, the Intel Sales Associate representing the customer, an updated floor plan of the customer facility, host operating system considerations and the quantity and type of components being installed.

The site survey team reviews the Site Survey Request Form to decide whether to approve the proposed Intel[®] PRO/Wireless 2011 LAN installation based on its likelihood to succeed. Once the Site Survey Request Form is generated, customer final approval is required before formally scheduling the site survey.

1.3.1 Scheduling the Site Survey

The site survey is scheduled as soon as the site survey team and the customer approve the Site Survey Request.

Chapter 2 Using the Site Survey Utility to Conduct a Site Survey

Use the Intel® PRO/Wireless 2011 LAN Site Survey utility to establish a two-way data network using both stationary and mobile devices at various points within the proposed radio coverage area. Assess AP signal strength using various antenna and AP configurations to determine areas requiring additional or higher performance antennas.

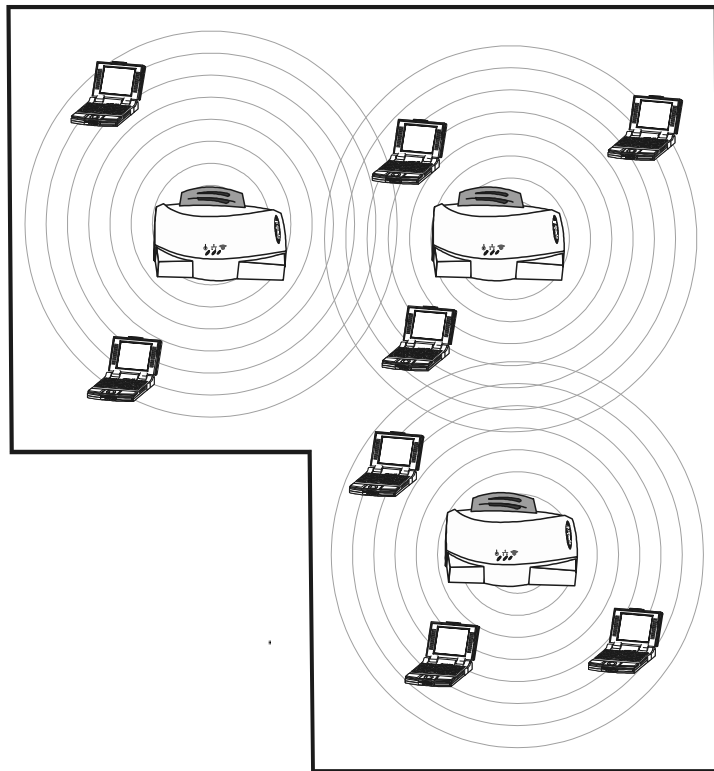

The Intel® PRO/Wireless 2011 LAN Site Survey utility runs under Windows 95/98, NT and 2000.

2.1 Installing the Intel[®] PRO/Wireless 2011 LAN Site Survey Utility

A Site Survey requires the site survey utility be loaded on the mobile devices and the desktop computer used in the survey.

2.1.1 Installing the Site Survey Utility from a CDROM

To install the Intel[®] PRO/Wireless 2011 LAN Site Survey utility from CDROM:

1. Insert the installation CDROM in the computer CD drive.
2. Click **Start** and select **Run**.
3. Enter `x:\Setup.exe`
where x represents the letter assigned to the CD drive.
4. Click **OK**.
5. Complete the installation following the instructions provided with the Intel[®] PRO/Wireless 2011 LAN Site Survey utility.
6. Select **Yes** when asked if backup copies of replaced files are required.

Selecting **Yes** invokes the site survey utility uninstall feature for possible use.

The Intel[®] PRO/Wireless 2011 LAN Site Survey utility installation is completed. Launch the site survey utility by clicking on the program icon appearing on the Windows desktop.

2.1.2 Copying the Site Survey Utility from the Intel Web Site to a Desktop Computer

To copy the Site Survey utility from the Intel Web site:

1. From a desktop computer, go to the Intel Web site (<http://support.intel.com>) and select the Intel[®] PRO/Wireless 2011 LAN Site Survey utility.

A *File Download* window appears prompting the user to run the utility from its current location or save it to disk.

2. Check the **Save this program to disk** option and click **OK**.
A **Save As** window appears prompting the user to enter the destination for the Intel® PRO/Wireless 2011 LAN Site Survey Utility.
3. Select the drive letter assigned to the desktop computer hard drive and click **Save**.
The zipped Site Survey utility files copy to the desktop computer hard drive.
4. Extract the Site Survey utility by double-clicking the Intel® PRO/Wireless 2011 LAN Site Survey utility icon and completing the instructions provided by the program.
Once the utility has been extracted to the desktop computer the utility installation is complete.

2.2 Creating a Trial Intel® PRO/Wireless 2011 LAN

Before using the Site Survey utility, an Intel® PRO/Wireless 2011 LAN wireless LAN infrastructure is created to test component radio signal strength.

In addition to the Site Survey utility, the following equipment is required to create an Intel® PRO/Wireless 2011 LAN:

- access points
- digital camera
- distance measurement wheel
- directional and omnidirectional antennas
- MUs with extra batteries
- Access point battery.

To install a trial Intel® PRO/Wireless 2011 LAN:

1. Connect the access point antenna(s).
2. Mount the access points.

Mount access points at the locations recommended on the floor plan drawing. Start with the most difficult coverage area first. Position the access points so the antennas are not obstructed.

3. Power on the access points.

Use battery power if an AC wall socket is not convenient.

4. Observe access point LED behavior.

Observe the LEDs to verify normal boot operation. After the boot cycle is complete, the STATUS LED flashes approximately once every second to indicate the access point is operating properly.



Component installations differ depending on the device installed. Refer to the documentation shipped with each component to ensure proper installation and configuration.

5. Power on the MUs used for the site survey.



The Site Survey utility should already be loaded on the mobile devices and desktop computer used to perform the survey.

When the device is powered on it displays a message indicating the access point is not connected to a boot server. This is normal since the access point is not yet connected to an Ethernet network.

6. Set the access point and MU Network IDs.

Set the MU(s) and access point to the same Net ID. Normally, the access point default value 101 is used.

An Intel® PRO/Wireless 2011 LAN now exists and can be tested for radio transmission effectiveness with the Site Survey utility.

2.3 Starting the Intel[®] PRO/Wireless 2011 LAN Site Survey Utility

To launch the Site Survey utility:

1. Click **Start** and select **Programs**.
2. Click **Intel Wireless LAN** and select **Site Survey**.
3. Click **Site Survey** and select **Site Survey** again.

The Site Survey utility **Welcome** dialog box displays.

Use the **Welcome** dialog box to open an existing site survey area workspace, create a new workspace, create a new workspace from an existing site survey area workspace (a template or a .sst file) or open a recently used workspace.

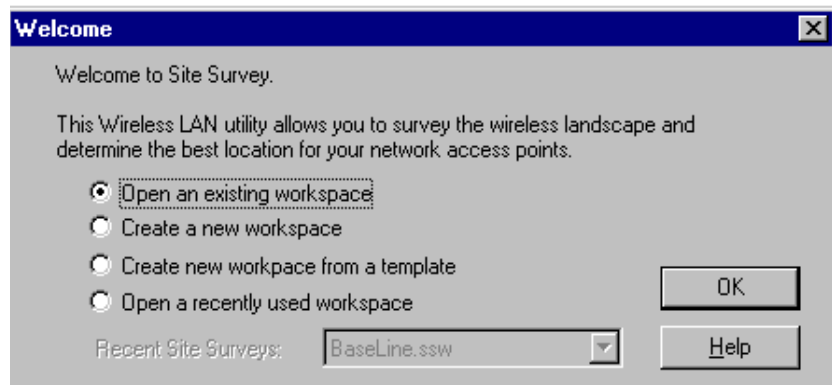

If an existing site survey workspace is opened containing one or more survey areas, the **Site Survey Test** dialog box displays. Use the **Site Survey Test** dialog box to specify the ICMP test parameters for the survey area. If an existing survey workspace does not have a survey area defined, the **Site Survey** dialog box displays. Use the **Site Survey** dialog box for entering the site survey area name, surveyor and description. The **Site Survey Test** and **Site Survey** dialog boxes are described in greater detail in the sections that follow.

Closing the **Welcome** dialog box enables the **File**, **Edit**, **View**, **Area** and **Help** pull-down menus. Use these menus to create a new site survey, view radio coverage areas within an existing site survey template, run a ping test for a survey area, display and configure the **Edit** menu property pages and display help information for the usage of the utility.

2.4 Navigating the Site Survey Utility File Menu

Use the File menu to create a new survey area workspace, open an existing survey workspace, define a new survey area, save the survey workspace, work with a report, import survey workspace data and display recent survey information.

| | |
|--------------------------------|--------|
| <u>N</u> ew Site Survey... | Ctrl+N |
| <u>O</u> pen Site Survey... | Ctrl+O |
| New <u>A</u> rea... | Ctrl+A |
| <u>S</u> ave Site Survey | Ctrl+S |
| Save Site Survey <u>A</u> s... | |
| <u>I</u> mport... | Ctrl+I |
| Open Report... | |
| Save Report | |
| Save Report As... | |
| <u>P</u> rint... | Ctrl+P |
| Print Preview | |
| Print Setup... | |
| Recent Site Survey Files | ▶ |
| <u>E</u> xit | |

2.4.1 Creating a New Site Survey

Select **New Site Survey** from the **File** menu or click on the application toolbar button resembling a sheet of paper to open a **Site Survey** dialog box. Use the **Site Survey** dialog box to enter the site name, surveyor and description. If a workspace is open, the user is prompted to save the existing workspace first. Click **OK** to save the new workspace information. The status bar at the bottom of the screen displays the new workspace name.

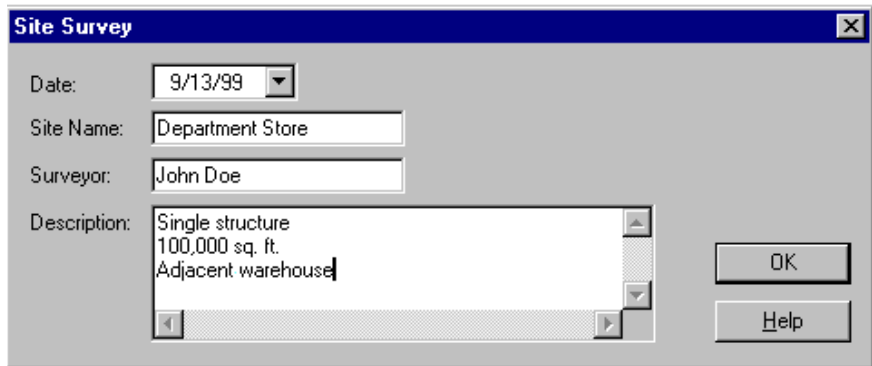

2.4.2 Selecting an Existing Site Survey

Select **Open Site Survey** from the **File** menu to open a standard Windows dialog box displaying files with the extension.ssw. If an invalid file is read, an error message displays, otherwise, a progress dialog box displays and the workspace is loaded. The **Site Survey Test** dialog box displays if the workspace has at least one defined area. The **Site Survey Area** dialog box displays if the existing workspace does not have a defined area. The status bar displays the workspace and area name.

2.4.3 Defining a New Site Survey Area

Select **New Area** from the **File** menu to display a **Site Survey Area** dialog box. Use the **Site Survey Area** dialog box to enter the area name and description. The **Delete** button is grayed when defining a survey area. The **Test Name** field lists the tests defined for that area. Add a new test by clicking the ellipsis (...) button. An error message displays if the **Area Name** field is left blank or the name of an existing area is entered. The area name displays at the bottom of the screen.

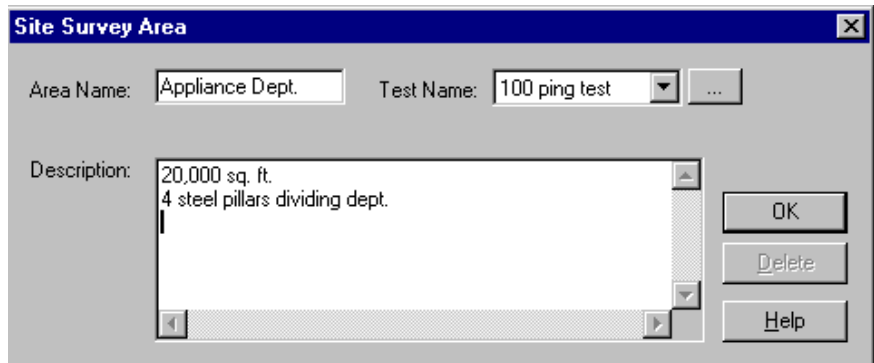

2.4.4 Save/Save As

Select **Save** from the **File** menu or click on the application toolbar resembling a diskette to save the open workspace using the existing survey name. Select **Save As** from the **File** menu to save the survey using a different name.

2.4.5 Importing a Site Survey

Select **Import** from the **File** menu to display an **Import Areas and Tests** dialog box. Use the **Import Areas and Tests** dialog box to import survey areas and/or tests from another survey workspace. Select **Import Areas** and/or **Import Tests** to replace existing survey areas and tests or to add new ones. Click the **Import** button to display a standard Windows dialog box displaying files with the extension **.ssw**.

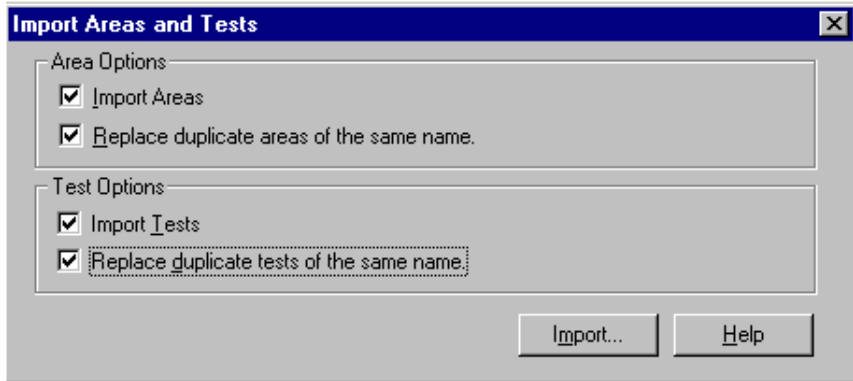

2.4.6 Working With Reports

A Site Survey Report can be generated, edited and printed for each site survey workspace. The **Site Survey Report** is a WordPad document generated when the survey is complete. The report can be edited as a typical WordPad document. The template for a new report has the filename **Site Survey Results.doc** and is installed in the same directory as the program executable.

2.4.7 Displaying Recent Site Surveys

Select **Recent Site Surveys** from the **File** menu to display the last four site survey workspace files created or accessed. Selecting any workspace in the list loads that workspace. If there is at least one **Area** defined for the workspace, the **Site Survey Test** dialog box displays. The status bar at the bottom of the dialog box displays the status, filename, area name, and workspace name. If a workspace is already open, the user is prompted to save the existing workspace first.

2.5 Navigating the Edit Menu

The **Site Survey Edit** menu contains **Site Survey**, **Area** and **Default Settings** pull-down menus. It also contains items for WordPad editing.



Use these menu items to edit an open Intel® PRO/Wireless 2011 LAN site survey, display a list of coverage areas within the workspace and use the **Setup**, **Meter Settings**, **Sounds** and **Logging** property pages to configure surveyor, system sounds and test data logging information. Use the menu items below **Default Settings** to edit the report file.

2.5.1 Editing Existing Site Survey Information

Select **Site Survey** from the **Edit** menu or select the application toolbar button resembling an open folder to display the **Site Survey** dialog box. Use the **Site Survey** dialog box to enter the site name, surveyor, and description. If a workspace is already open, the user is prompted to save the existing workspace. Click **OK** to save the edited workspace information.

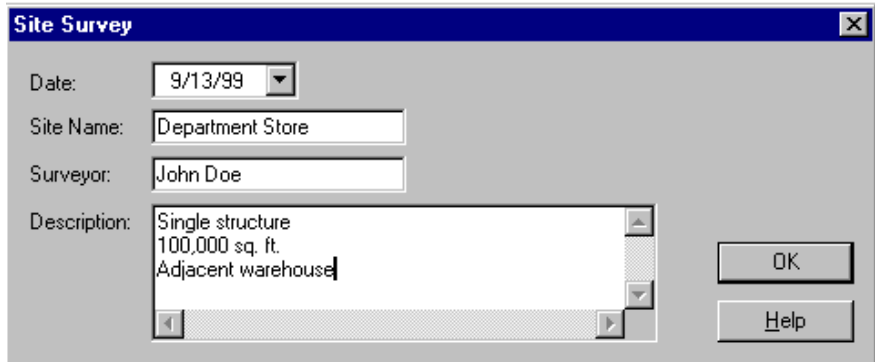

The screenshot shows a dialog box titled "Site Survey". It contains the following fields and controls:

- Date:** A dropdown menu showing "9/13/99".
- Site Name:** A text box containing "Department Store".
- Surveyor:** A text box containing "John Doe".
- Description:** A text area containing "Single structure", "100,000 sq. ft.", and "Adjacent warehouse".
- Buttons:** "OK" and "Help" buttons are located on the right side of the dialog.

2.5.2 Editing the Properties of an Existing Site Survey Area

Select **Area** from the **Edit** menu to display the **Site Survey Area List** dialog box. Use the **Site Survey Area List** dialog box to display a list and description of survey areas. Select an area and click **Edit Area** to display the **Site Survey Area** dialog box. Add new tests and survey area descriptions as needed. Click **OK** to save the changes to the site survey workspace. Click **Delete** to remove the area from the current site survey workspace.

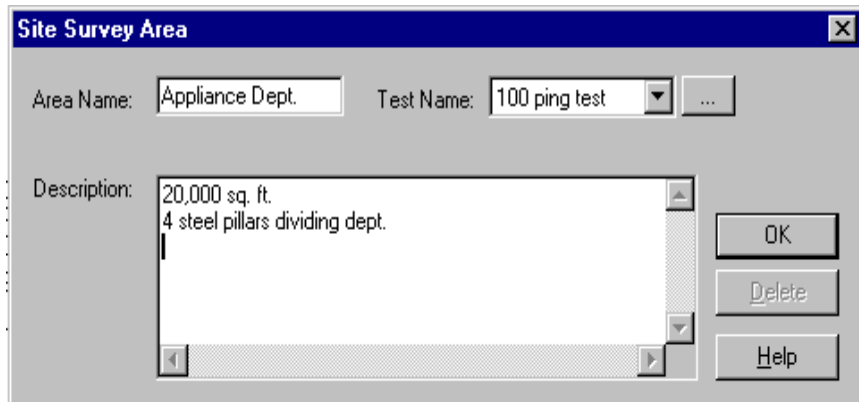
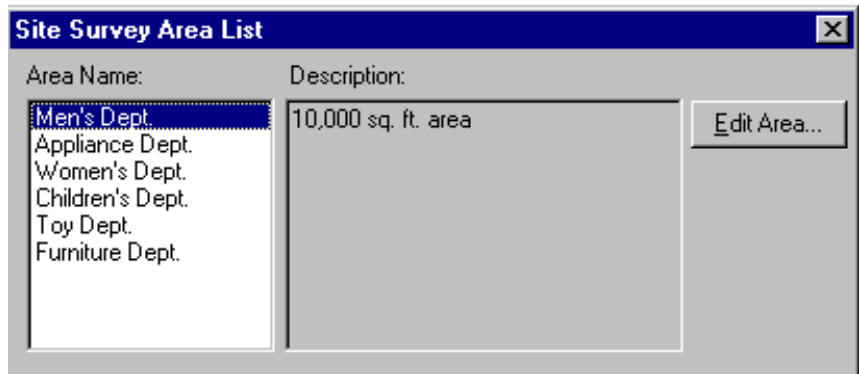

2.5.3 Editing the Default Settings Property Pages

Select **Default Settings** from the **Edit** menu or click on the application toolbar resembling a hand pointing to a card to access the **Setup**, **Meter Settings**, **Sounds** and **Logging** property pages. Use these property pages to change default settings for the current site survey workspace.

Setup Property Page

Select the **Setup** property page to change the following default site survey workspace information:

Surveyor. Enter the surveyor name in the **Surveyor** field to automatically update the **New Site Survey** dialog box. Click **OK** to save the updated surveyor name in the registry for subsequent surveys.

Auto Rerun. Run the **Site Survey** utility in either automatic or manual mode. If **Auto Rerun** is checked, the test suite runs for the rerun count or until the surveyor stops the tests.

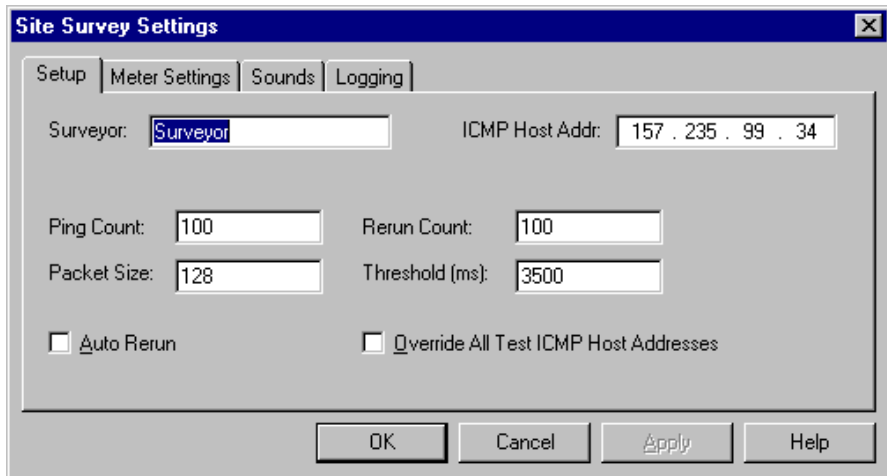

ICMP Host Addr. Enter an **ICMP Host Address** in the field provided. The default address is the default address of the AP.



If a pre 4.0 version of Internet Explorer is running on a Windows 95 (Rev B) system, the Setup Property Page does not display. Update Internet Explorer to version 4.0 or greater to resolve this problem.

Ping Count. Enter the number of pings to be transmitted during the ping test in the **Ping Count** field. The default Ping Count is 100, with a maximum of 2000.

Rerun Count. Enter the number of times the ping test is transmitted in the **Rerun Count** field. The default Rerun Count is 100. The rerun can be Continuous.

Packet Size. Enter the packet size transmitted during the ping test in the **Packet Size** field. The default Packet Size is 128 bytes, with a maximum of 1472 bytes.

Threshold Time. Enter the maximum acceptable time to send out and receive the total number of pings for each test in the **Threshold** field. Choose a Threshold Time from 1 milli-second to 100,000 milli-seconds. The default Threshold Time for 100 pings is 3500 milli-seconds.

Override All Test ICMP Host Addresses. Check this box to use the ICMP host address entered on this page for all tests. Checking this box does not replace the host address saved for each test.

Meter Settings Property Page

Select the **Meter Settings** property page to set bounds (thresholds) for the signal quality gradient bars in the Round Trip, Missed Beacon and Transmit Retry fields. The circular RTT Avg, Missed % and Retry % indicators on the **Site Survey Test** dialog box show green if the average of the previous tests (20 tests for RTT Avg, 40 tests for Retry % and 20 tests for Missed %) is below the lower threshold.

The circular indicators on the **Site Survey Test** dialog box show red if the average of the previous tests is above the upper threshold. Test results between the bounds set on the **Meter Settings** property page result in yellow displays on the circular indicators on the **Site Survey Test** dialog box. The circular indicators show green if the test results are below the lower bounds.

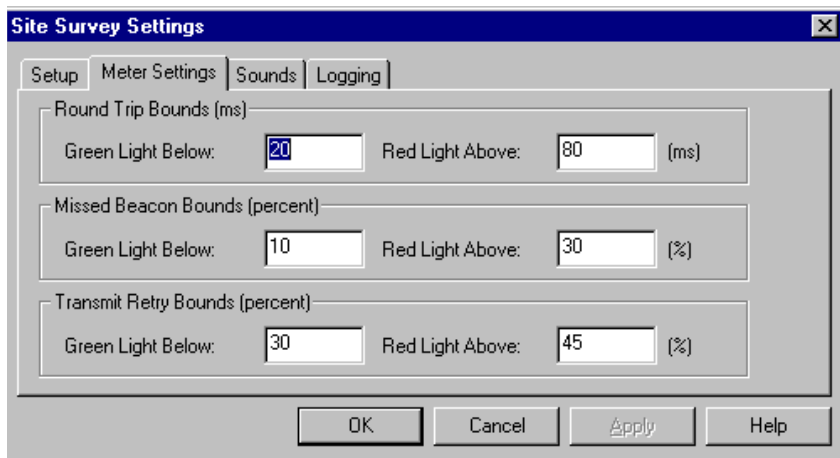

Sounds Property Page

Select the **Sounds** property page to change the following default site survey workspace information:

Play on Timeout. Select **Play on Timeout** to emit an audible timeout tone every time a ping test timeout is reached.

Play on Roam. Select **Play on Roam** to emit an audible roaming tone every time an MU roams between APs.

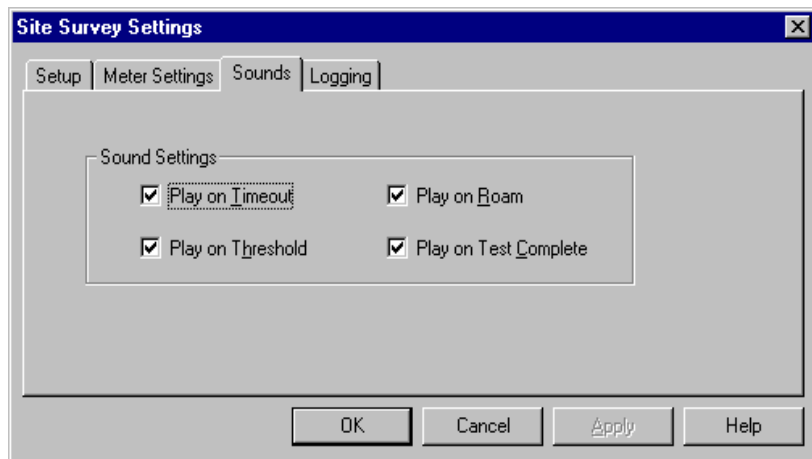

Play on Threshold. Select **Play on Threshold** to emit an audible threshold tone every time the threshold time is met or exceeded.

Play on Test Complete. Select **Play on Test Complete** to emit an audible test complete tone every time a suite of ping tests has been transmitted.

The default for the **Sounds** property page is all four sounds enabled. Set the volume level and/or sound by using the standard Windows Control Panel Volume and Sounds applet or the Sounds task tray applet.

Logging Property Page

Select the **Logging** property page to change the following default site survey workspace information:

Enable Logging. If unchecked, no logging takes place during the ping tests. The logfile consists of the date, time, and test settings (area name, test name, packet size, rerun count and signal quality boundaries). System messages and notes (if any) are also added to the logfile. If the user has chosen to record real-time test noise data and/or data points, they are also added to the logfile.

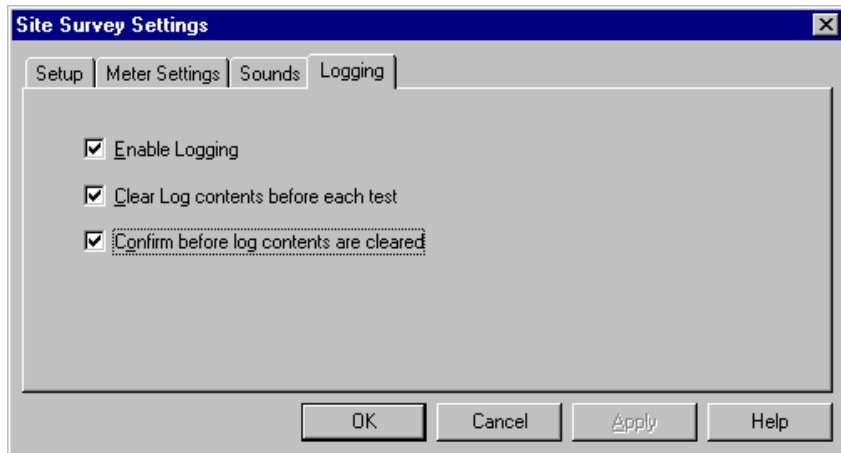

Clear Log contents before each test. Select **Clear Log** contents before each test to automatically clear the content of the log before a test suite is run.

Confirm before log contents are cleared. If checked, the surveyor is prompted whether the logfile should be cleared before the test suite is run.

2.6 Navigating the View Menu

The Site Survey utility View menu contains Adapter Info, Areas, Known APs, Noise Meter, Signal Quality and Generate Report pull-down menu items.

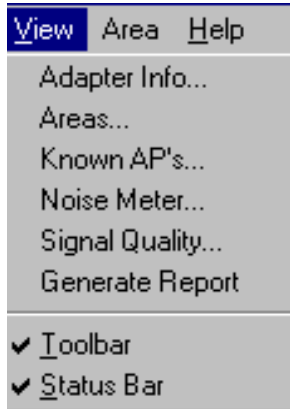

Use the menu items to view WLAN adapter driver and Firmware data, site survey areas, access points within range of a target mobile device and a graph depicting MU signal quality and to append the logfile to the report file. The status bar at the bottom of the main window can be displayed or hidden by checking or unchecking **Status Bar**. The tool bar buttons can be displayed or hidden by checking or unchecking **Toolbar**.

2.6.1 Viewing Adapter Info

Select **Adapter Info** from the **View** menu to display an **Adapter Information** dialog box. Use the **Adapter Information** dialog box to display WLAN adapter driver and Firmware version, adapter type and Firmware type, supported data rates and ESSID. The information is view only and cannot be modified.

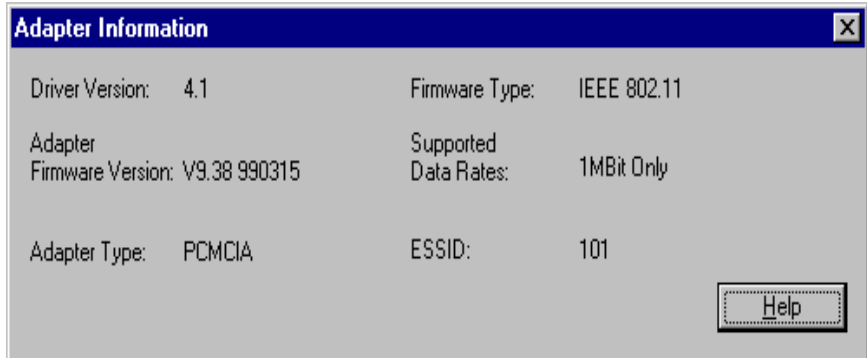

2.6.2 Viewing Site Survey Area Info

Select **Areas** from the **View** menu to display the **Site Survey Area List** dialog box. Use the **Site Survey Area List** dialog box to display a list and description of survey areas. Select an area and click **Edit Area** to display the **Site Survey Area** dialog box. Add new tests and survey area descriptions as needed. Click **OK** to save the changes to the site survey workspace. Click **Delete** to remove the area from the current site survey workspace.

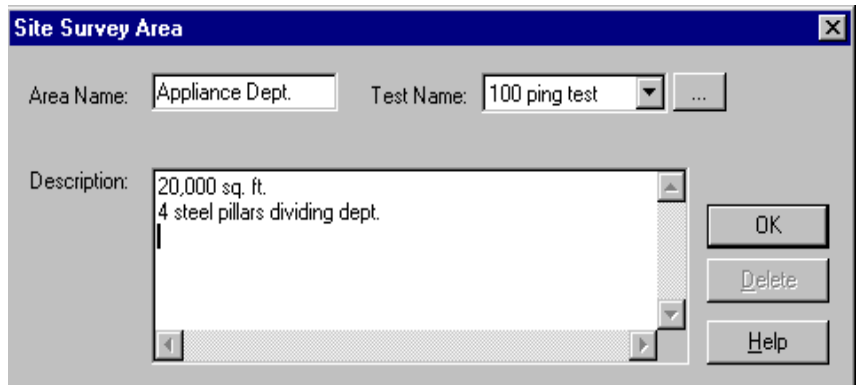
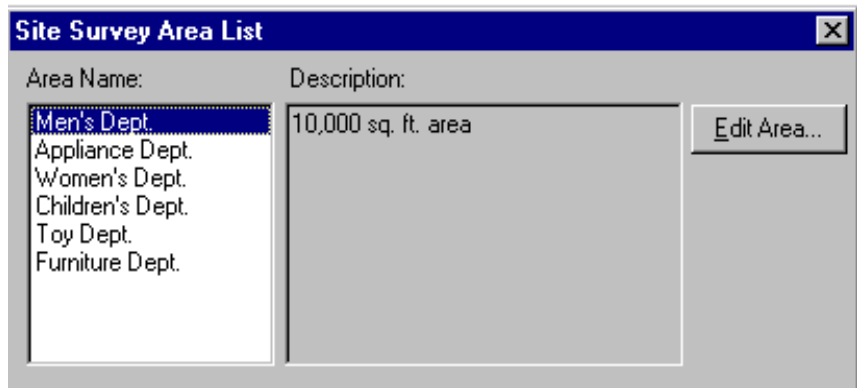

2.6.3 Viewing Access Point Info

Select **Known AP's** from the View menu to display the recognized access points in range of the target MU. Use the **Known AP's** dialog box to view the access point BSS ID, number of associated MUs, MU type and status and data rate. An icon next to each access point indicates whether the access point is mandatory or preferred and whether or not the access point is associated. A list of access points within range of the MU is also shown. Select an AP and right click to change the AP type to Mandatory or Roaming. Click the **Rates** button to display the **Transmission Rates** dialog box. Use the **Transmission Rates** dialog box to set the transmission rate to 1 Mbit, 2 Mbit, 5.5 Mbit or 11 Mbit. Checking multiple rates defaults the MU to a lower rate if the higher rate AP association cannot be established. If no rate is checked, the transmission rate is that of the wireless LAN adapter.



The Rates button is only enabled in frequency-hopping systems. It is not available in direct-sequence systems.

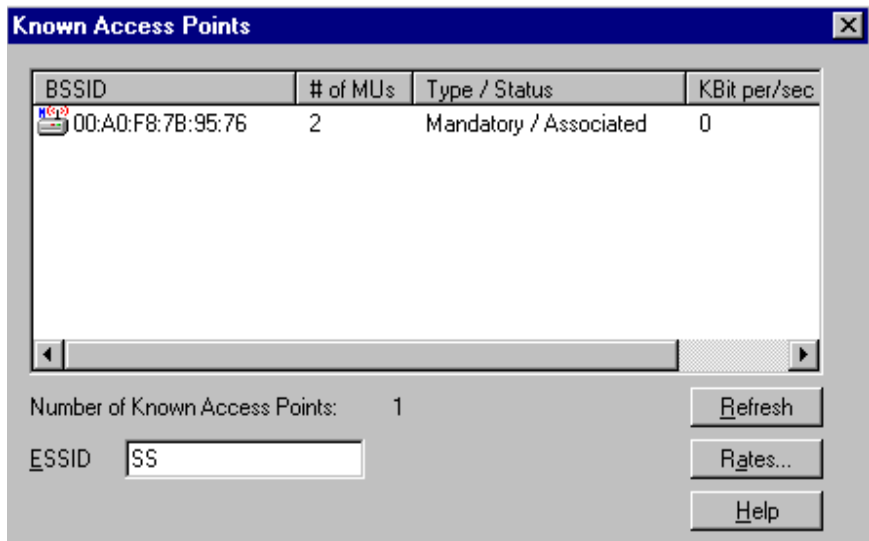

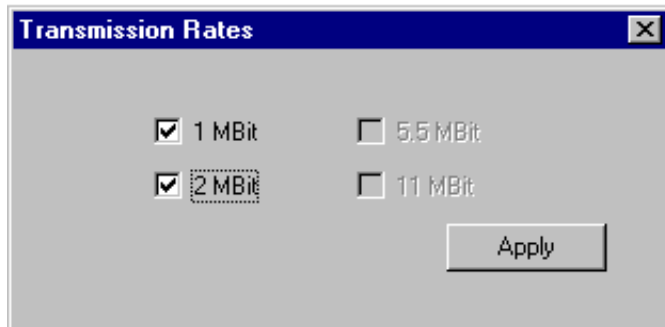

2.6.4 Viewing Mobile Unit Noise Info

Select **Noise Meter** from the View menu or click the application toolbar button resembling a colored bar graph. One of two graphs display depending on the type of network equipment being used.

Frequency-Hopping Spread Spectrum

In a frequency-hopping spread spectrum network a graph of Relative Signal Strength Indicator (RSSI) values and channel numbers displays. Use the **Noise Meter** dialog box to view the MU BSS ID and the RSSI minimum, maximum and average values. The RSSI values displayed in the graph are continuously updated with the last six received values displayed in blue. Click **Reset** to reset the graph to zero and click **Go** to begin a new display as RSSI values are received. Check **Record Real Time Data** to append RSSI values to the logfile.

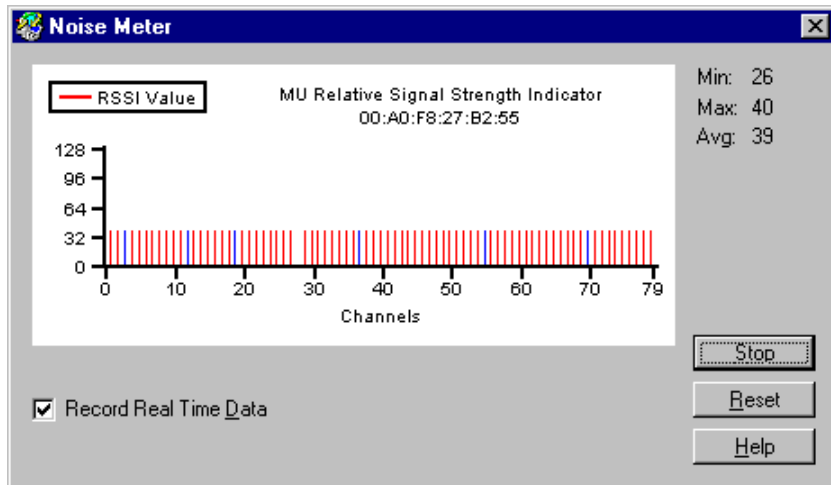

Direct-Sequence Spread Spectrum

In a direct-sequence spread spectrum network two graphs can display. For adapter version 1.0 a graph illustrating channel quality, average signal level and average noise level displays. The channel quality ranges from 0 to 31 and is calculated as the difference between the average signal level and the average noise level. These levels are averages calculated over time. The channel quality minimum, maximum and average values are displayed and the graph is continuously updated. Click **Reset** to reset the graph to zero. Click **Go** to begin a new display as channel quality values are received. Check **Record Real Time Data** to append channel quality values to the logfile. For adapter version 2.0 or above, only the average signal level displays. The scale remains 0 to 31.

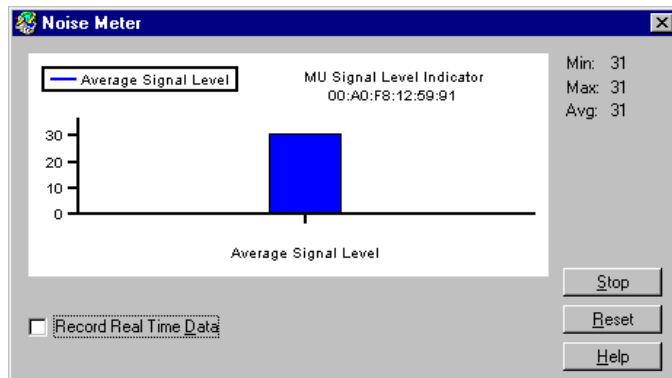

2.6.5 Viewing Mobile Unit Signal Quality Info

Select **Signal Quality** from the **View** menu to display the real-time percentage of missed beacons, the percentage of transmission retries and the percentage of CRC errors. Use the **Signal Quality** dialog box to display the strength of the radio signal transmitted by an access point. This information is useful in determining if the trial site survey access point placement locations are effective for providing radio coverage to the proposed radio coverage area.

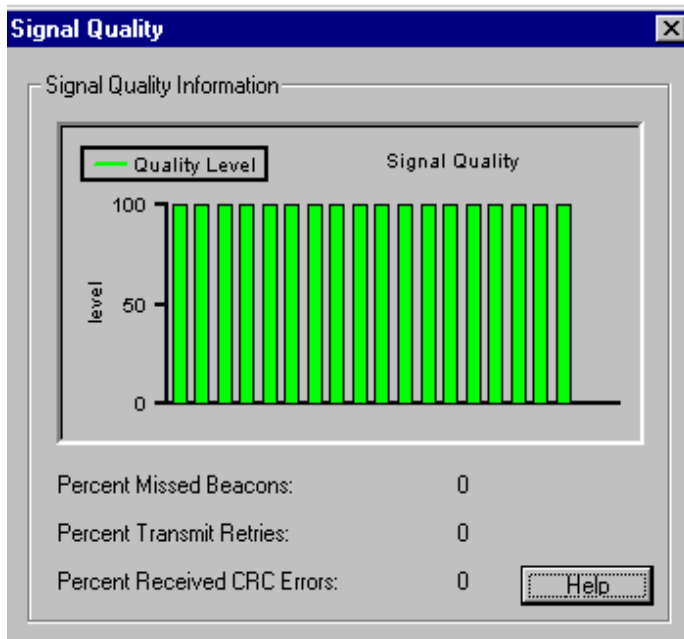

2.6.6 Generating the Site Survey Report

An Intel® PRO/Wireless 2011 LAN Site Survey Report can be generated for each site survey workspace. The report contains an overview of the survey, installation considerations, warranty information, survey findings, equipment placement recommendations and a detailed results section.

The report is a Microsoft WordPad document that can be generated when the survey is complete. The report can be edited and printed using the Cut, Copy, Paste and Print application toolbar buttons. The template for a new report has a Site Survey Results.doc filename and is installed in the same directory as the program executable.

2.7 Navigating the Area Menu

The Site Survey utility Area menu contains **New**, **Select**, **Clear Log Contents**, **Edit Note** and **Run ICMP Test** and **Run Throughput Test** menu items.

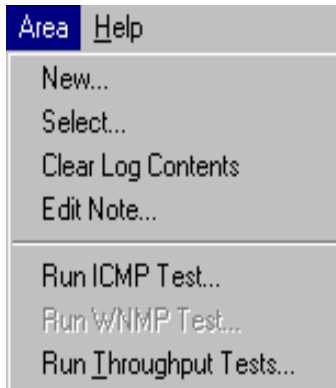

Use the menu items to create or edit a site survey area, view the settings of a survey area, clear a site survey log, add notes to the survey log, run ICMP tests and run throughput (FTP) tests.

2.7.1 Creating a New Survey Area

Select **New** from the **Area** menu to display a **Site Survey Area** dialog box. Use the **Site Survey** dialog box for entering a survey area name and description. If a workspace is already open, the user is prompted to save the existing workspace. Click **OK** to add the area to the workspace.

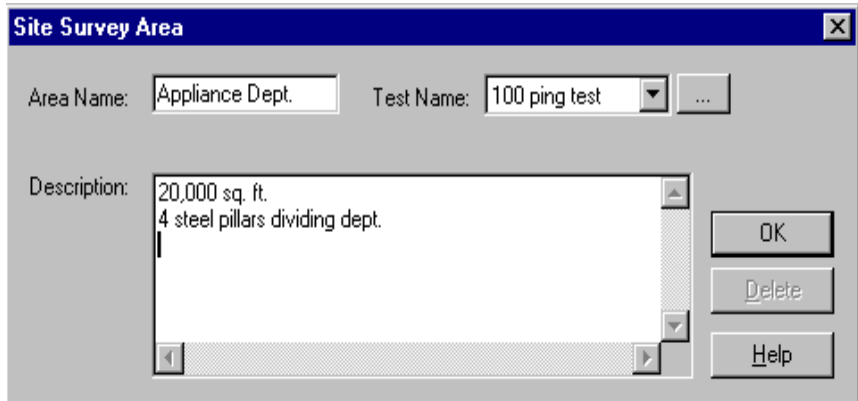

The screenshot shows a dialog box titled "Site Survey Area" with a close button (X) in the top right corner. The dialog contains the following fields and controls:

- Area Name:** A text input field containing "Appliance Dept."
- Test Name:** A dropdown menu showing "100 ping test" and a button with three dots ("...") to the right.
- Description:** A text area containing "20,000 sq. ft." and "4 steel pillars dividing dept." with a vertical scrollbar on the right.
- Buttons:** Three buttons are located on the right side: "OK", "Delete", and "Help".

2.7.2 Selecting and Editing an Existing Survey Area

Click **Select** from the **Area** menu to display the **Site Survey Area List** dialog box. Use the **Site Survey Area List** dialog box to display a list and description of survey areas. Select an area and click **Edit Area** to display the **Site Survey Area** dialog box. Add new tests and survey area descriptions as needed. Click **OK** to save the changes to the site survey workspace. Click **Delete** to remove the area from the current site survey workspace.

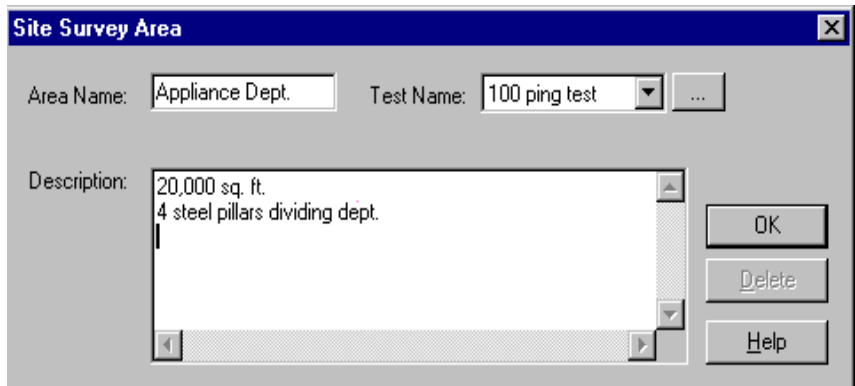
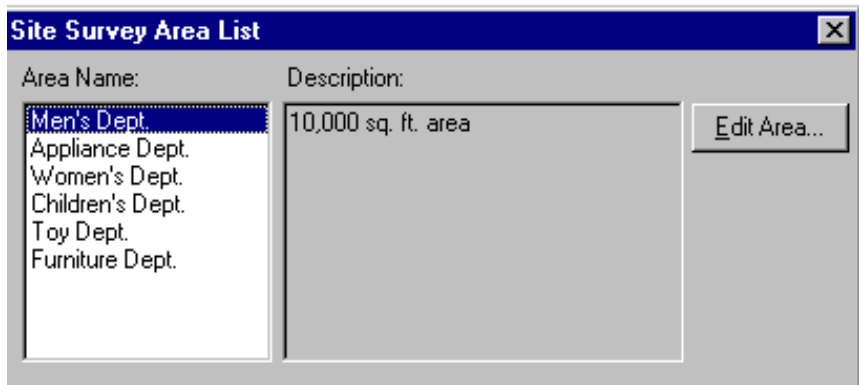

2.7.3 Clearing the Text File Log for an Open Survey Area

Use the **Clear Log Contents** option to delete the log contents for the active survey workspace.

2.7.4 Editing the Note File for an Open Survey Area

Select **Edit Note** from the **Area** menu to display the **Note Editing** dialog box. Use the **Edit Note** option to add notes to the logfile of the active survey workspace.

2.7.5 Running ICMP Tests

Select **Run ICMP Test** from the **Area** menu or select the **ICMP** toolbar button to display the **Site Survey Test** dialog box.

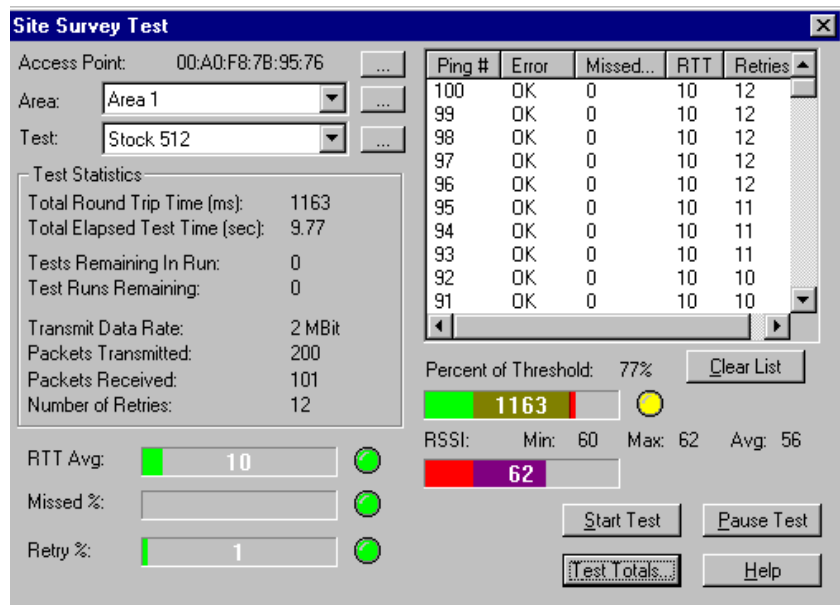

Use the **Site Survey Test** dialog box to specify ICMP test parameters. ICMP tests are ping tests assessing radio transmission roundtrip, delay time and transmission signal strength. Click **Start Test** to begin the test.

Setting ICMP Test Parameters

Use the **Site Survey Test** dialog box to set the following ICMP test parameters:

Access Point. The **Access Point** field of the **Site Survey Test** dialog box lists the associated access point. Choose a different access point from the list of available access points by clicking the ellipsis button.

Area. Define a new survey area by selecting “(New)” from within the **Area** pull-down list and clicking the ellipsis button.

Test. Use the **Test** pull-down list to display the tests defined for the workspace. Use the ellipsis button to enter new test settings or edit existing test settings.

Test Statistics. Use the **Test Statistics** field of the **Site Survey Test** dialog box to view the total roundtrip ping time, elapsed test time, tests remaining in the run, the number of test runs remaining, the transmit data rate, packets transmitted, packets received and the number of retries. A graph of RSSI (for frequency-hopping) or average signal level (for direct-sequence) displays.

Four graphs on the bottom of the **Site Survey Test** dialog box display an average roundtrip time, missed beacon percentage, retry percentage, and threshold percentage. Bounds (thresholds) set in the **Meter Settings** property page establish the limits for the variables in the graphs.

Results List Box. Use the **Results List Box** to view ping count, errors, cumulative retries, roundtrip time and missed beacons percentage. Scroll backward or forward in the list. The list box holds 1000 pings.

Start Test. Click **Start Test** to begin the ICMP test. Once started, the **Start Test** button changes to a **Stop** button.

Edit Note. Click **Edit Note** to display a dialog box for entering notes for the test. Each note is added to the logfile.

Clear List. Use the **Clear List** button in **Site Survey Test** dialog box to clear the results list box.

Test Totals. Click the Test Totals button to display the Site Survey Totals dialog box.

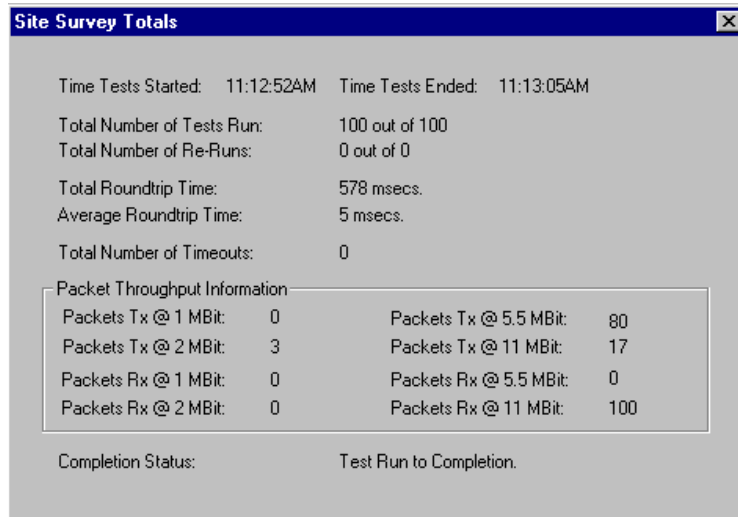

Use the Site Survey Totals dialog box to display the time the tests were started and stopped, the number of tests run, number of re-runs, total roundtrip time, average roundtrip time, total number of timeouts and the test completion status. Packet throughput information is summarized as the number of packets sent and received and the data rates for each. These values are recorded in the logfile if logging is enabled.

Progress Bars. Use the gradient progress bars to view RTT Avg, Missed %, Retry % and the percent of threshold achieved during the test. The numerical value is displayed in white in the middle of each progress bar. The bars change color as the values approach the lower and upper bounds. Green indicates a value below the lower bound, yellow indicates a value between the bounds and red indicates a value greater than the upper bound.

Percent of Threshold. The percent of threshold (established in the Setup property page) that the sum of the round-trip times are approaching. The white number in the middle of the progress bar is the sum of the round-trip times.

Setting New Test Parameters

Select "(New)" from the Test pull-down list box in the Site Survey Test dialog box. Open the New Test Settings dialog box by clicking the ellipsis button (...) next to the Test pull-down list box.

The screenshot shows a dialog box titled "New Test Settings". It contains the following fields and options:

- Test Name: 100 ping test
- Host Address: 157.235.115.114
- Rerun Count: 100
- Ping Count: 100
- Packet Size: 128
- Threshold (ms): 3500
- Options:
 - Auto Rerun
 - Sounds
 - Logging
- Buttons: OK, Delete, Advanced..., Help

Use the New Test Settings dialog box to enter a test name, define test packet sizes, select a test ping count, enable the test Auto Rerun, Sounds and Logging features, change host address information and display the Settings property pages.

Test Name. Use the Test Name field in the New Test Settings dialog box to enter the test for the active survey area.

Packet Size. Use the Packet Size field in the New Test Settings dialog box to enter a packet size for the ICMP test.

Ping Count. Use the Ping Count field in the New Test Settings dialog box to type in a ping count value for the ICMP test.

Threshold. Use the Threshold field in the New Test Settings dialog box to type in threshold value (in milli-seconds) for the ICMP test. This is the total round-trip ping transmission threshold.

Host Address. The host address entered in the **Settings Setup** property page displays in the **Host Address** field. Change the host address value by typing it in.

Auto Rerun. Select the **Auto Rerun** option in the **New Test Settings** dialog box to enable the Auto Rerun test feature.

Enable Sounds. Select the **Enable Sounds** option in the **New Test Settings** dialog box to enable the Sounds feature.

Logging. Select the **Logging** option in the **New Test Settings** dialog box to enable the Logging feature.

Advanced. Click the **Advanced** button in the **New Test Settings** dialog box to access the **Advanced Test Settings** property pages for the active survey area workspace. Use the **Settings** property pages (**Meter Settings**, **Sounds** and **Logging**) to change the default settings for the current site survey workspace.

2.7.6 Running Throughput Tests

Select **Run Throughput Tests** from the **Area** menu or select the **FTP** toolbar button to display the **FTP Test** dialog box.

The screenshot shows the 'FTP Test' dialog box with the following details:

- FTP Server Information:**
 - FTP Site Name: 157.235.99.162
 - User Name: (empty)
 - User Password: (empty)
 - Anonymous login:
- File Transfer Information:**
 - Get file from Site: (selected)
 - Put file to Site:
 - Log Results:
 - Get / Put Filename: ftpTest.pch
 - Default Site Directory: (empty)
 - FTP run count: 10
 - Qmit Lows/Highs from Transfer Rate Average:
 - Start button
- Test Results:**

| | | | |
|---------------|----------|---------------|--------------|
| Operations: | 0 | Rate High: | 0 Bytes/Sec. |
| Total Bytes: | 0 | Rate Low: | 0 Bytes/Sec. |
| Rate Average: | 0 K/Sec. | Rate Average: | 0 Bytes/Sec. |

Use the **FTP Test** dialog box to specify throughput test parameters. Throughput tests are File Transfer Protocol (FTP) tests.

Setting Throughput Test Parameters

Use the **FTP Test** dialog box to set the following test parameters:

FTP Site Name. Use the **FTP Site Name** field to enter the IP address or site name of the FTP site.

Anonymous Login. Check the **Anonymous Login** checkbox to login without a username or password.

User Name. Enter the user name for the FTP site.

User Password. Enter the password for the FTP site.

Get file from Site. Select the **Get file from Site** radio button if the file specified in the Get/Put Filename field is to be transferred from the site.

Put file to Site. Select the **Put file to Site** radio button if the FTP file is to be transferred to the site.

Log Results. Check the **Log Results** checkbox if the FTP test results are to be written to the logfile.

Get/Put Filename. Enter the path and filename of the FTP file. The ellipsis button next to the edit box is enabled when **Put file to site** is selected. Click the ellipsis button to navigate to a file.

Default Site Directory. Select **Default Site Directory** to optionally specify a subdirectory on the FTP server.

FTP Run Count. The FTP run count is the number of times to transfer the FTP file.

Omit Lows/Highs from Transfer Average. Check this box to eliminate outliers from being used in the Transfer Rate Average calculation. Outliers are those transmit times lower or higher than the current shortest or longest transmit time.

Test Results. Use the **Test Results** section of the FTP Test dialog box to view the number of Operations, Total Bytes, Rate Average (K/Sec), Rate High, Rate Low and Rate Average (Bytes/Sec).

Click **Start** to begin the throughput test.

Chapter 3 **Conducting a Size Specific Site Survey**

Site surveys differ depending on the size of the survey site. Smaller sites are surveyed for one or two access points to provide coverage over a space no larger than a single room. Medium sized sites could require between 10 and 20 access points and be the size of a warehouse or several rooms. Large sites could require between 20 and 100 access points and be a large building with different radio coverage service areas in different parts of the building.

3.1 **Conducting a Survey for a Small Area**

To conduct a survey in a site where 1 or 2 access points are anticipated:

1. Consult with the designated customer contact person.
Discuss any special installation requirements. Determine the type of cables to be connected to the access points (10 Base T, 10 Base 2, fiber optic).
2. Document the size and layout of coverage area.
Document RF systems already in use, location of host system, and available AC power.
3. Set up an access point in the middle of the room or where it is estimated that the coverage cell will be the largest.
4. Walk the perimeter of the coverage area and measure radio coverage.
For an 11 Mbit direct-sequence network, study round-trip ping times and data rates. The individual round-trip ping time is usually about 7 ms before the rate changes from 11 Mbits to 5.5 Mbits (using a packet size of 1024 bytes). Another set of statistics is obtained by clicking the **Test Totals** button. The **Totals** dialog displays the number of packets transmitted and received and the rates for each. Move the terminal in different directions. Position the terminal between the surveyor and the access point. Do not walk fast or coverage area dead spot could be missed.



Depending on the coverage requirements, the perimeter for each of the data rates might have to be determined separately. For an FH network, run 100 pings with a packet size of 512 bytes. Total test time for 1 Mbit should be less than 13 seconds; 12 seconds for 2 Mbit.

5. Mark the location of access points on the blueprint, move the access point to the second survey location and repeat the procedure.

6. Consult with customer technical personnel.

Infrastructure backbone, hubs and patch panels should all be documented . Document the conditions existing in the final installation.

7. Complete the Site Survey Report.

The report indicates the number and location of the access points. Assign the access points the same channel for each coverage area.

3.2 Conducting a Survey for a Medium Sized Area

To conduct a survey in a site where 10 - 20 access points are anticipated:

1. Consult with the designated customer contact person.

Discuss any special installation requirements. Determine the type of cables to be connected to the access points (10 Base T, 10 Base 2, fiber optic).

2. Document the size and layout of the coverage area.

Document RF systems already in use, location of host systems, available AC power, possible antenna locations, interfering metal fire breaks and wall structures, doorways and passages that could help RF propagation, and amount of stock in coverage areas. For a warehouse, document how high the stock is kept and how high the lifts go so that the lifts do not damage the access points.

3. Set up an access point at one side of the proposed coverage area.

4. Walk the perimeter and measure radio coverage.

If there are multiple floors, measure each floor separately. For an 11 Mbit direct-sequence network, document round-trip times and data rates. The individual round-trip ping time is usually about 7 ms before the rate changes from 11 Mbits to 5.5 Mbits (using a packet size of 1024 bytes). Move the terminal in different directions. Position the terminal between the surveyor and the access point. Do not walk fast or a radio coverage dead spot might be missed.

5. Document the boundry of each coverage area as the data rates could be different in aeach area.

The access point could only be moved a few feet to result in better coverage. For 11 Mbit high data rate networks, reflection is more of a problem (ceiling sprinklers can cause a problem if the access point antenna is less than 2 feet away). For a FH network, run 100 pings with a packet size of 512 bytes. Total test time for 1 Mbit should be less than 13 seconds; 12 seconds for 2 Mbit.

6. Mark the location of each access point on the blueprint and move the access point to different trial location.

Continue the process until the entire site has radio coverage.

7. Take a picture of at least one access point location for each coverage are.

If each coverage area has unique features, take a picture of each. Take pictures of racks, stock level, hub locations and racks. The pictures go into the report and help establish the condition of the site as it was surveyed.

8. Consult with customer technical personnel and document any additional hubs that could be required (14 or more access points could require multiple hubs).

Consider exact conditions that exist in the final installation.

9. Complete the Site Survey Report.

The report indicates the number and location of the access points. Assign the access points the same channel for each coverage area.

3.3 Conducting a Survey for a Large Area

To conduct a survey in a site where 20 - 100 access points are anticipated:

1. Consult with the designated customer contact person.

Discuss any special installation requirements. Determine the type of cables to be connected to the access points (10 Base T, 10 Base 2, fiber optic).

2. Document the size and layout of the coverage area.

Document RF systems already in use, location of host systems, available AC power, possible antenna locations, interfering metal fire breaks and wall structures, doorways and passages that could help RF propagation, and amount of stock in coverage areas. For a warehouse, document how high the stock is kept and how high the lifts go so that the lifts do not damage the access points.

3. Set up an access point at one side of the proposed coverage area.

4. Walk the perimeter and measure radio coverage.

If there are multiple floors, measure each floor separately. For an 11 Mbit direct-sequence network, document round-trip times and data rates. The individual round-trip ping time is usually about 7 ms before the rate changes from 11 Mbits to 5.5 Mbits (using a packet size of 1024 bytes). Move the terminal in different directions. Position the terminal between the surveyor and the access point. Do not walk fast or a radio coverage dead spot might be missed.

5. Document the boundary of each coverage area as the data rates could be different in each area.

The access point could only be moved a few feet to result in better coverage. For 11 Mbit high data rate networks, reflection is more of a problem (ceiling sprinklers can cause a problem if the access point antenna is less than 2 feet away). For a FH network, run 100 pings with a packet size of 512 bytes. Total test time for 1 Mbit should be less than 13 seconds; 12 seconds for 2 Mbit.



Site survey boundary areas for multiple buildings should also be considered for large surveys. Determine if a LAN bridge and or wireless access points are required.

6. Mark the location of each access point on the blueprint and move the access point to different trial location.
Continue the process until the entire site has radio coverage.
7. Take a picture of at least one access point location for each coverage area.
If each coverage area has unique features, take a picture of each. Take pictures of racks, stock level, hub locations and racks. The pictures go into the report and help establish the condition of the site as it was surveyed.
8. Consult with customer technical personnel and document any additional hubs that could be required (14 or more access points could require multiple hubs).
Consider exact conditions that exist in the final installation.
9. Complete the Site Survey Report.
The report indicates the number and location of the access points. Assign the access points the same channel for each coverage area.

Appendix A

Intel[®] PRO/Wireless 2011 LAN Overview

For applications where mobility and real-time wireless communications are essential, Intel[®] PRO/Wireless 2011 LAN provides high throughput, expandable capacity, straightforward installation and superior interface simplicity. Intel[®] PRO/Wireless 2011 LAN support for the IEEE 802.11 standard for wireless LANs safeguards a wireless LAN investment by ensuring flexibility and broad industry support.

The Intel Site Survey utility uses direct-sequence (DS) and frequency-hopping (FS) technology.

Intel[®] PRO/Wireless 2011 LAN infrastructure products include:

- bridging architecture to provide communication between radio and wired multiple network segments
- a design based on the IEEE 802.11 standard
- roaming for mobile users with devices such as laptops, wireless computers, scanning terminals and other computers with PCMCIA slots.

A.1 Radio Basics

Intel® PRO/Wireless 2011 LAN devices use both *electromagnetic waves* and radio signals to transmit and receive electric signals without wires. Users communicate with the network by establishing radio links between terminals and APs.

Intel® PRO/Wireless 2011 LAN uses *FM (frequency modulation)* to transmit digital data from one device to another. Using FM, a radio signal begins with a carrier signal that provides the base or center frequency. The digital data signal is superimposed on the *carrier signal (modulation)*. The radio signal propagates into the air as electromagnetic waves. A receiving antenna in the path of the waves absorbs the waves as electrical signals. The receiving device demodulates the signal by removing the carrier signal. This demodulation results in the original digital data.

Intel® PRO/Wireless 2011 LAN uses the *environment* (the air and certain objects) as the transmission medium. Intel® PRO/Wireless 2011 LAN radio devices transmit in the 2.4 to 2.5-GHz frequency range, a license-free range throughout most of the world. The actual range is country-dependent.

Intel® PRO/Wireless 2011 LAN devices, like other Ethernet devices, have unique, hardware-encoded *Media Access Control (MAC)* or *IEEE addresses*. MAC addresses determine the device sending or receiving data. A MAC address is a 48-bit number written as six hexadecimal bytes separated by colons. For example:

00:A0:F8:24:9A:C8

To locate the AP MAC address see the bottom of the unit.

A.1.1 Network Topology

The possible network topologies depend on the following factors:

- the AP function in the network
- the data transfer rate.

Select from the following topologies:

- A single access point used without the wired network provides a single-cell wireless network for peer-to-peer MUs.

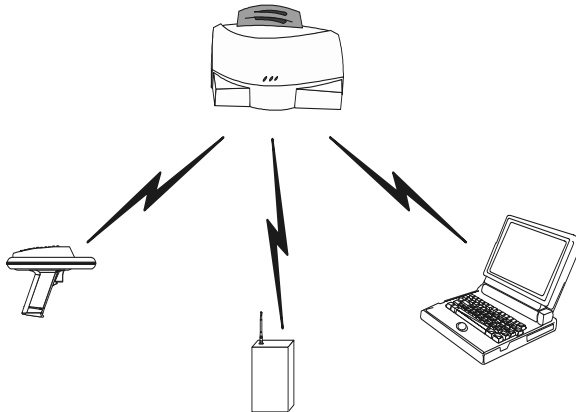

- A single access point can bridge the Ethernet and radio networks.

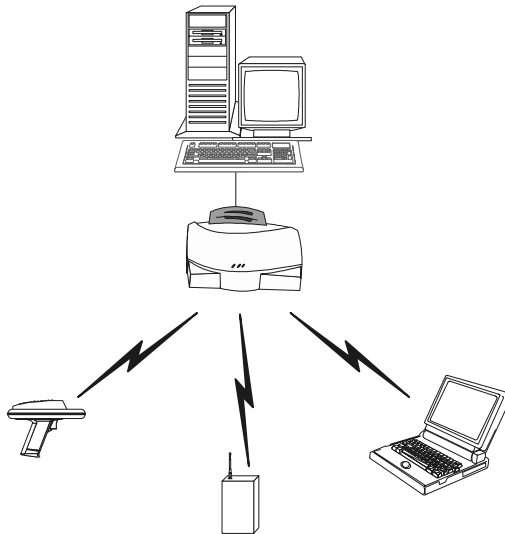

- Multiple access points can coexist as separate, individual networks at the same site without interference using different Net_IDs.

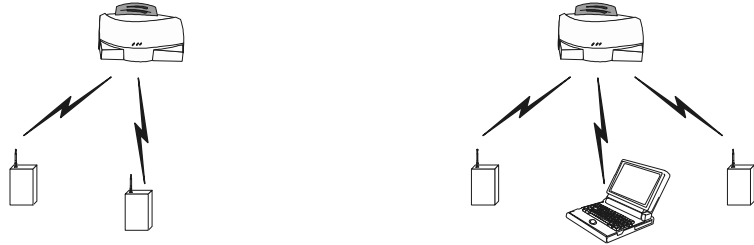

- Multiple access points wired together provide a network with better coverage area and performance.

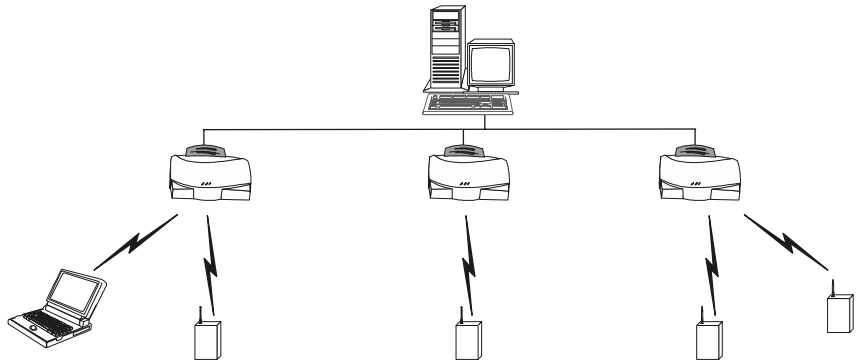

A.1.2 Cellular Coverage

The access point establishes an average communication range with MUs called a *Basic Service Set (BSS)* or *cell*. When in a particular cell the MU associates and communicates with the access point of that cell. Each cell has a *Basic Service Set Identifier (BSS_ID)*. In 802.11, the access point MAC

address represents the BSS_ID. The MU recognizes the access point it associates with using the BSS_ID. Adding access points to a LAN establishes more cells in an environment, making it an RF Network using the same Net_ID or Extended Service Set (ESS).

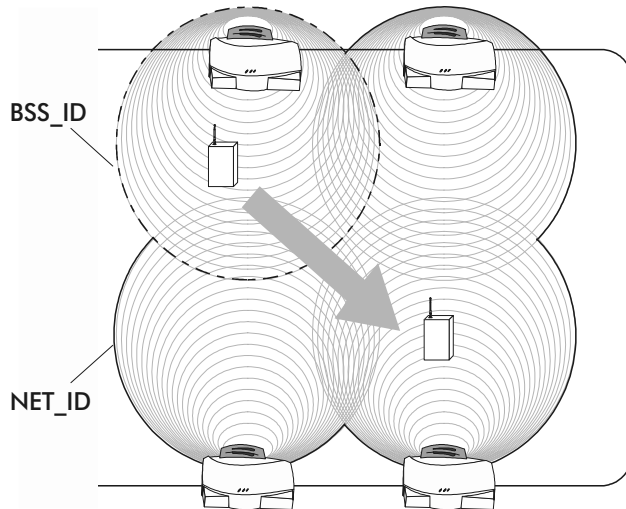

Access points with the same Net_ID (ESS) define a coverage area. The MU searches for access points with a matching Net_ID (ESS) and synchronizes with an access point to establish communications. This allows MUs within the coverage area to move about or roam. As the MU roams from cell to cell, it switches access points. The switch occurs when the MU analyzes the reception quality at a location and decides which access point to communicate with based on the best signal strength and lowest MU load distribution.

If the MU does not find an access point with an acceptable signal, it performs a scan to find any access point. As MUs switch access points, the access point updates the *association table*. Roaming is invisible to the user in high-level applications.

A.2 Access Point (AP)

The *Access Point (AP)* provides a bridge between Ethernet wired LANs and Intel® PRO/Wireless 2011 LAN. It provides connectivity between Ethernet wired networks and radio-equipped *mobile units (MUs)*. MUs include the full line of Intel terminals, PC Cards and PCI adapters, scanners, third-party devices and other devices.

The access point monitors Ethernet traffic and forwards appropriate Ethernet messages to MUs over the network. It also monitors MU radio traffic and forwards MU packets to the Ethernet LAN.

The access point meets:

- the regulatory requirements for Europe and many other areas of the world
- FCC part 15, class A with no external shielding
- FCC part 15 class B, ETS 300-339 compliance, including CE mark.

An MU communicating with an access point appears on the network as a peer to other network devices. The access point receives data from its wired interfaces and forwards the data to the proper interface.

The access point has connections for the wired network, external antennas and a power supply. The access point attaches to a wall or ceiling depending on installation-site requirements.

The access point requires a single antenna for radio transmission and reception. The dual-antenna system option allows the access point to select the best radio signal.

A.3 Advanced Radio Theory

To improve access point management and performance, users need to understand basic access point functionality and configuration options. The access point includes features for different interface connections and network management.

The access point provides *MAC layer bridging* between its interfaces. The access point monitors traffic from its interfaces and, based on frame address, forwards the frames to the proper destination. The access point tracks the frames sources and destinations to provide intelligent bridging as MUs roam or network topologies change. The access point also manages broadcast and multicast message initiations and responds to MU association requests.

A.3.1 MAC Layer Bridging

The AP listens to all packets on all interfaces and builds an address database using the unique IEEE 48-bit address (MAC address). An address in the database includes the interface media that the device uses to associate with the access point. The access point uses the database to forward packets from one interface to another. The bridge forwards packets addressed to unknown systems to the Default Interface (either Ethernet or PPP). Users can use the Ethernet interface as a wireless access point interface.

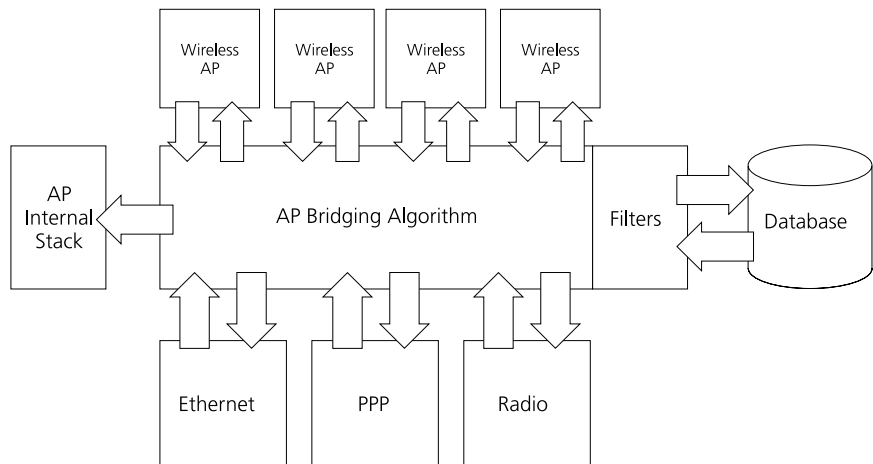

The access point internal stack interface manages all messages directed to the access point.

Each access point stores information on destinations and their interfaces to facilitate *forwarding*. When a user sends an *ARP (Address Resolution Protocol)* request packet, the access point forwards it over all enabled interfaces (Ethernet, PPP and radio) except over the interface the ARP request packet was received. On receiving the ARP response packet, the access point

database keeps a record of the destination address along with the receiving interface. With this information, the access point forwards any directed packet to the correct destination. The access point forwards packets for unknown destinations to the Ethernet interface.



ARP request packets received over radio echo back to other access points over radio.

The access point removes from its database destinations or interfaces not used for a specified time. The access point refreshes its database when it transmits or receives data from these destinations and interfaces.

A.3.1.1 Filtering and Access Control

The access point provides facilities to limit the MUs that associate with it and the data packets that can forward through it. Filters provide network security and improve performance by eliminating broadcast/multicast packets from the radio network.

The *ACL (Access Control List)* contains MAC addresses for MUs allowed to associate with the access point. This provides security by preventing unauthorized access.

The access point uses a *disallowed address* list of destinations. This feature prevents the access point from communicating with specified destinations. This can include network devices that do not require communication with the access point or its MUs.

Depending on the setting, the access point can keep a list of frame types that it forwards or discards. The *Type Filtering* option prevents specific frames (indicated by the 16-bit DIX Ethernet Type field) from being processed by the access point. These include certain broadcast frames from devices unimportant to the wireless LAN, but take up bandwidth. Filtering out unnecessary frames can improve performance.

A.3.2 DHCP Support

The access point uses *Dynamic Host Configuration Protocol (DHCP)* to obtain a leased IP address and network configuration information from a remote server. DHCP is based on BOOTP protocol. DHCP can coexist or interoperate with BOOTP. An access point sends out a *DHCP request* searching for a *DHCP server* to acquire the network configuration and firmware filenames. Because BOOTP and DHCP interoperate, the one that responds first becomes the server that allocates information. The DHCP client automatically sends a DHCP request every XX hours/days to renew the IP address lease as long as the access point is running. (This parameter is programmed at the DHCP server. Example: Windows NT servers typically are set for 3 days.)

The access point can download two files when a boot takes place, the firmware file and an HTML file, since firmware version 1.00 and above supports Web servers. Users can program the DHCP or BOOTP server to transfer these two files when a DHCP request is made.

When the access point receives a network configuration change or is not able to renew the IP address lease the access point sends out an SNMP trap.

A.3.3 Media Types

The access point supports bridging between Ethernet, radio and serial media.

The *Ethernet interface* fully complies with Ethernet Rev. 2 and IEEE 802.3 specifications. The access point supports 10Base-T wired connections and full-speed filtering. The data transfer rate over radio waves is 11 Mbps. The Ethernet interface is optional for single-cell or PPP-connected networks.

The *radio interface* conforms to IEEE 802.11 specifications. The interface operates at 11 Mbps using direct-sequence radio technology. The access point supports multiple-cell operations with fast, transparent roaming between cells. With the direct-sequence system, each cell operates independently. Each cell provides an 11 Mbps bandwidth. Adding cells to the network increases coverage area and total system capacity. The access point supports MUs operating in *Power Save Polling (PSP)* mode or *Continuously Aware Mode (CAM)* without user intervention.

The *DB-9, 9-pin, RS-232 serial port* provides a *UI (User Interface)* or a *PPP (Point to Point Protocol)* connection. The UI provides basic management tools for the access point. The PPP provides a link between APs using a serial connection. The serial link supports *short haul (direct serial)* or *long haul (telephone-line)* connections. The access point is a *DTE (Data Terminal Equipment)* device with male pin connectors for the RS-232 port. Connecting the access point to a computer requires a null modem cable and connecting the access point to a modem requires a straight-through cable.

A.3.4 Bridging Support

The access point PPP (*Point to Point Protocol*) interface, accessible from the serial port at the rear of the access point, provides two types of bridging operations:

- Data-link bridging between two access points. A network using a data-link bridge provides radio coverage by using a remote access point in a location geographically distant from the access point connected to the Ethernet network. The remote access point cannot provide an Ethernet connection to other access points. MUs associating with the remote access point transmit and receive from the Ethernet network via the PPP link.

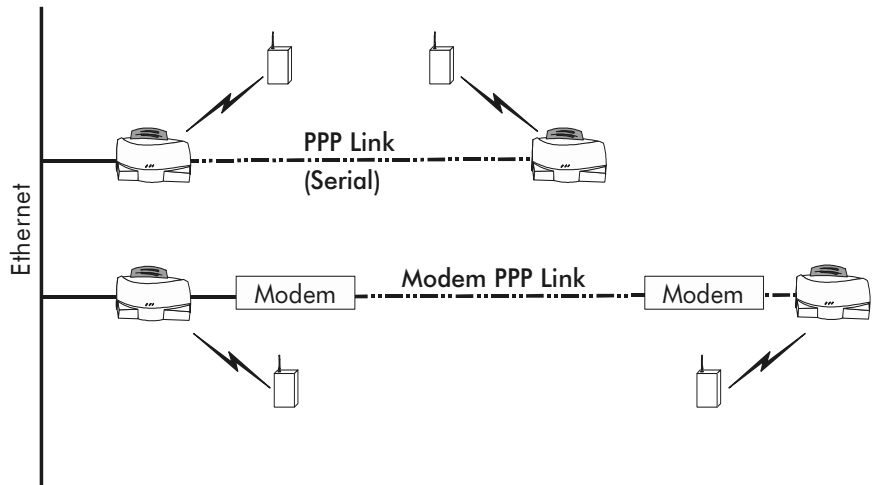

- Internet Protocol bridging between an access point and a computer. To establish an Internet Protocol bridge with an access point, ensure the computer includes the appropriate Telnet software with PPP and TCP/IP protocols. Using Telnet, a remote computer can connect to any access point on an Ethernet network, as long as data transfers through IP packets.

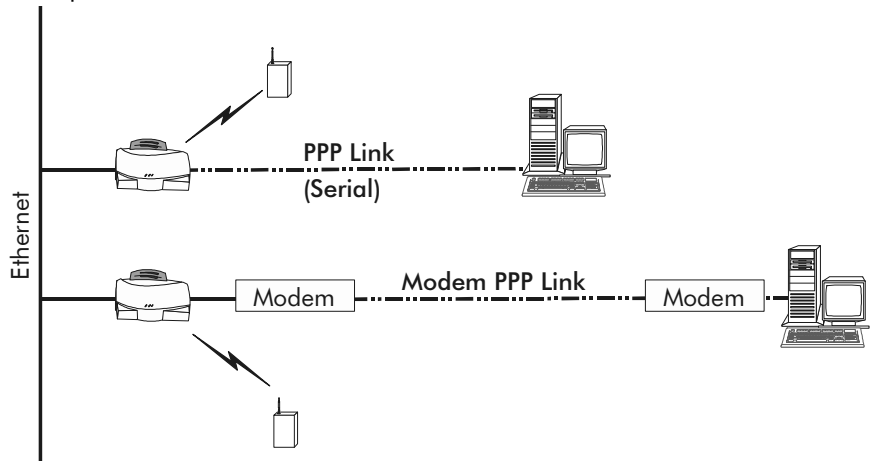

A PPP link provides the option of using a direct serial link or modem to extend wired Ethernet topologies.

Once in PPP mode, the access point automatically attempts to communicate with the other device using the *Data-Link Bridging (DLB)* protocol. An access point using DLB communicates on the MAC level, and receives and transmits Ethernet frames.

If the other device does not support DLB, the access point attempts to communicate using *Internet Protocol Control Protocol (IPCP)*. An access point using IPCP communicates on the IP level, and receives and transmits *IP (Internet Protocol)* packets.

The PPP implementation in the access point uses the *Link Control Protocol (LCP)* and *Network Control Protocol (NCP)* as described in:

- RFC 1171: the Point-to-Point Protocol, July 1990
- RFC 1220: PPP Extensions for Bridging, April 1991
- RFC 1332: The PPP Internet Protocol Control Protocol, May 1992
- RFC 1661: The Point-to-Point Protocol, July 1994.

RFCs are *Requests For Comments* used in Internet Communities.

The access point database dynamically tracks MUs and access points on the PPP interface. The access point forwards packets to the PPP link after determining their destination.



The PPP implementation in the access point uses the NCP as described in *RFC 1220: PPP Extensions for Bridging* to encapsulate packets at the Ethernet level. The PPP provides IP bridging control as defined by *RFC 1172 and MAC-level bridging*. It provides support for PPP negotiations conforming to *RFC 1661*. Users cannot plug a non-AP node directly into the access point serial port, only AP-to-AP PPP links.

Refer to *RFC 1171: The Point to Point Protocol* and *RFC 1220: PPP Extensions for Bridging* for information.

A.3.4.1 PPP Connection

Connecting two access points with a direct serial link requires a null-modem serial cable.

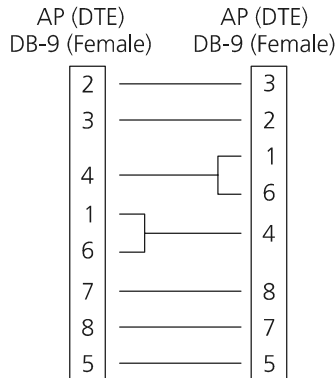

Connecting two access points with modem devices requires straight-through cables between the access points and modems. Using modems requires a telephone line for as long as the link remains active.

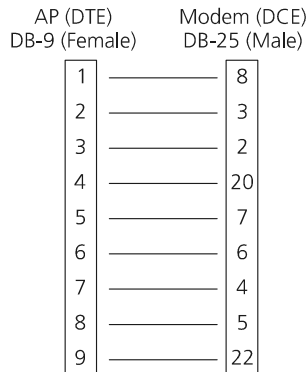

When using a modem connection, one access point represents the originating access point and the other represents the answering access point. When using a PPP link, do not use the serial port to access the UI. Access to the UI requires establishing a Telnet session with the access point.

A.3.5 Direct-Sequence Spread Spectrum

Spread spectrum (broadband) uses a narrowband signal to spread the transmission over a segment of the radio frequency band or spectrum. Direct-sequence is a spread spectrum technique where the transmitted signal is spread over a particular frequency range. The Intel® PRO/Wireless 2011 LAN Access Point uses direct-sequence spread spectrum (DSSS) for radio communication.

Direct-sequence systems communicate by continuously transmitting a redundant pattern of bits called a *chipping sequence*. Each bit of transmitted data is mapped into *chips* by the access point and rearranged into a pseudorandom *spreading code* to form the chipping sequence. The chipping sequence is combined with a transmitted data stream to produce the access point output signal.

Direct Sequence

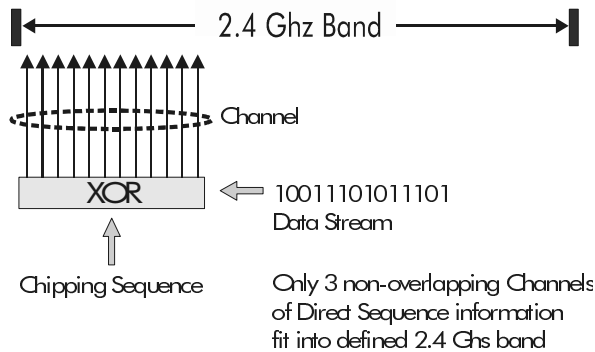

Mobile units receiving a direct-sequence transmission use the spreading code to map the chips within the chipping sequence back into bits to recreate the original data transmitted by the access point. Intercepting and decoding a direct-sequence transmission requires a predefined algorithm to associate the spreading code used by the transmitting access point to the receiving MU.

This algorithm is established when the access point and MU are configured. The bit redundancy within the chipping sequence enables the receiving MU to recreate the original data pattern, even if bits in the chipping sequence are corrupted by interference.

The ratio of chips per bit is called the *spreading ratio*. A high spreading ratio increases the resistance of the signal to interference. A low spreading ratio increases the bandwidth available to the user. The access point uses two chips per bit among three channels within the 2.4 GHz band in a pattern avoiding any 1 or 2 Mbps systems operating in the same area. The access point is capable of an 11 Mbps data transmission rate, but the coverage area is less than a 1 or 2 Mbps access point since coverage area decreases as bandwidth increases.

A.3.6 Frequency-Hopping Spread Spectrum

Frequency Hopping Spread Spectrum (FHSS) spreads radio signals by transmitting a short burst on one frequency, jumping to another frequency for another short burst and so on. Intel® PRO/Wireless 2011 LAN uses the 2.4 - 2.5 GHz range depending on the country, this range does not require licensing from the FCC. FHSS offers a higher transmission rate than a conventional radio narrowband method.

In FHSS systems, the carrier frequency of the transmitter changes (or hops) in accordance with the pseudo-random code sequence. The code sequence dictates the frequency order selected by the transmitter. The transmitter takes the input data and spreads it in a predefined method. Each receiver has to understand this predefined method and reconstruct the signal before interpreting data. Stations in a cell using FHSS techniques hop or change the carrier frequency at synchronized intervals. Government regulatory agencies and standards, such as ETSI, MKK, the FCC and IEEE 802.11, determine the number of frequency *hops* (79 for the U.S.), the *hopping pattern* (sequence each frequency is used) and *dwel time* (time at each frequency). The FCC requires 75 or more hopping frequencies used and a maximum of 400ms for dwel time per frequency. The transmitter and receiver synchronize to the

hop sequence to ensure communication. The time synchronization field included in message packets coordinates the hop timing of all units. The user can program the length each hop lasts. Each hop is a frequency at least 6 MHz away from the previous frequency and has a 1 MHz bandwidth.

FHSS can survive in an adverse environment and coexist with other devices/services in the same band. The average signal strength being relatively low on any given frequency is a result of FHSS. When the signal intelligence is spread out over several MHz in the frequency spectrum, the resulting power spectrum also spreads out (less than 1 watt). This results in the transmitted power spread out over a wide frequency bandwidth and makes detection very difficult (with out the code sequence).

Hopping provides enhanced data reception in the presence of interfering signals, like fixed frequency radio networks or microwave ovens. The system also resists interference because it spends a short time on each given frequency. If an interfering source is present (interference at a specific frequency), only a small number of frequency hops are blocked instead of the entire range. With interference occurring on one frequency, the data is retransmitted on a subsequent hop at another frequency. Even if constant interference exists on a given frequency, it affects the radio network for only a short time on that specific frequency. Although access points can share the same hopping sequence, they usually do not synchronize in time. Rarely do they simultaneously arrive at the same frequency, referred to as contention. Interfering signals can reduce overall throughput at some frequencies. This reduces the probability and impact of overlapping frequencies or collisions. Although devices can hop to the same frequency, they eventually hop to different frequencies after the hop time.

With Intel® PRO/Wireless 2011 LAN, each access point on the local network negotiates a different hopping sequence at start-up. This allows access points to provide frequency separation and evenly divide the frequency spectrum among the units.

A.3.7 MU Association Process

Access points recognize MUs as they associate with the access point. The access point keeps a list of the MUs it services. MUs associate with an access point based on the following conditions:

- the signal strength between the access point and MU
- the MUs currently associated with the access point
- the MU Supported Rate (see table below).

| Data Rate | Requirement |
|------------------|--------------------|
| 11 Mbps | Optional |
| 5.5 Mbps | Optional |
| 2 Mbps | Optional |
| 1 Mbps | Required |

MUs perform preemptive roaming by intermittently scanning for access points and associating with the best available access point. Before roaming and associating with access points, MUs perform full or partial scans to collect access point statistics and determine the direct-sequence channel used by the access point.

Scanning is a periodic process where the MU sends out probe messages on all frequencies defined by the country code. The statistics enable an MU to reassociate by synchronizing its frequency to the access point. The MU continues communicating with that access point until it needs to roam between cells.

MUs perform full scans at start-up. In a full scan, an MU uses a sequential set of channels as the scan range. For each channel in range, the MU tests for CCA (*Clear Channel Assessment*). When a transmission-free channel becomes available, the MU broadcasts a probe with the Net_ID and the broadcast BSS_ID. An AP-directed probe response generates an MU ACK (*Mobile Unit Acknowledgment*) and the addition of the access point to the access point table with a proximity classification. An unsuccessful access

point packet transmission generates another MU probe on the same channel. If the MU fails to receive a response within the time limit, it repeats the probe on the next channel in the sequence. This process continues through all channels in the range.

MUs perform partial scans at programmed intervals, when missing expected beacons or after excessive transmission retries. In a partial scan, the MU scans access points classified as proximate on the access point table. For each channel, the MU tests for CCA. The MU broadcasts a probe with the Net_ID and broadcast BSS_ID when the channel is transmission-free. It sends an ACK to a directed probe response from the access point, and updates the access point table. An unsuccessful access point packet transmission causes the MU to broadcast another probe on the same channel. The MU classifies an access point as out-of-range in the access point table if it fails to receive a probe response within the time limits. This process continues through all access points classified as proximate on the access point table.

An MU can roam within the coverage area by switching access points. Roaming is transparent and virtually instantaneous in high-level applications. Roaming occurs when:

- an unassociated MU attempts to associate or reassociate with an available access point
- the supported rate changes or the MU finds a better transmit rate with another access point
- the *RSSI (received signal strength indicator)* of a potential access point exceeds the current access point
- the ratio of good-transmitted packets to attempted-transmitted packets falls below a threshold
- the MU detects an imbalance in the number of MUs associated with available access points and roams to a less loaded access point.

An MU selects the best available access point and adjusts itself to the access point direct-sequence channel to begin association. Once associated, the access point begins forwarding any frames it receives addressed to the MU. Each frame contains fields for the current direct-sequence channel. The MU uses these fields to resynchronize to the access point.

A.3.8 Mobile IP

The Internet Protocol identifies the MU point of attachment to a network through its IP address. The access point routes packets according to the location information contained in the IP header. If the MU roams across routers to another subnet, the following situations occur:

- The MU changes its point of attachment without changing its IP address, causing forthcoming packets to become undeliverable.
- The MU changes its IP address when it moves to a new network, causing it to lose connection.

Mobile IP enables an MU to communicate with other hosts using only its home IP address after changing its point-of-attachment to the internet/intranet.

Mobile IP is like giving an individual a local post office forwarding address when leaving home for an extended period. When mail arrives for the individual home address, it is forwarded by the local post office to the current care-of-address. Using this method, only the local post office requires notification of the individual current address. While this example represents the general concept of Mobile IP operation and functionality, it does not represent the implementation of Mobile IP used.

A tunnel is the path taken by the original packet encapsulated within the payload portion of a second packet to some destination on the network.

A *Home Agent* is an access point acting as a router on the MU home network. The home agent intercepts packets sent to the MU home address and tunnels the message to the MU at its current location. This happens as long as the MU keeps its home agent informed of its current location on some foreign link.

A *Foreign Agent* is an access point acting as a router at the MU location on a foreign link. The foreign agent serves as the default router for packets sent out by the MU connected on the same foreign link.

A *care-of-address* is the IP address used by the MU visiting a foreign link. This address changes each time the MU moves to another foreign link. It can also be viewed as an exit point of a tunnel between the MU home agent and the MU itself.

The *Mobile IP (roaming across routers)* feature enables an MU on the Internet to move from one subnet to another while keeping its IP address unchanged.



Note

To configure Mobile IP, see the Product Reference Guide included with the access point.

The scanning and associating process continues for active MUs. This allows the MUs to find new access points and discard out-of-range or deactivated access points. By testing the airwaves, the MUs can choose the best network connection available.

The following diagram illustrates Mobile IP (roaming across routers):

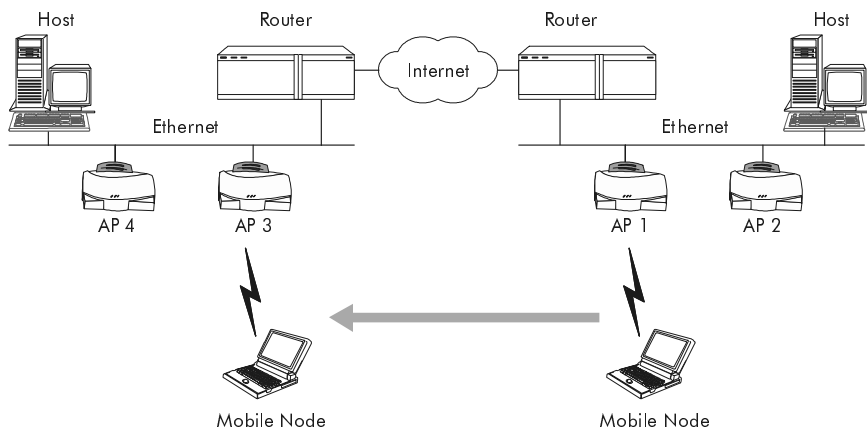



Set the MU for Mobile IP as specified in the MU user documentation.

Security has become a concern to mobile users. Enabling the *Mobile-Home MD5 key* option in the *System Configuration* menu generates a 16-byte *checksum authenticator* using an *MD5 algorithm*. The MU and access point share the *checksum*, called a *key*, to authenticate transmitted messages between them. The access point and MU share the key while the MU is visiting a foreign subnet. The MU and AP have to use the same key. If not, the access point refuses to become the *Home Agent* for the MU. The maximum key length is 13 characters. The access point allows all printable characters.

A.3.9 Supporting CAM and PSP Stations

CAM (Continuously Aware Mode) stations leave their radios on continuously to hear every beacon and message transmitted. These systems operate without any adjustments by the access point. A *beacon* is a uniframe system packet broadcast by the access point to keep the network synchronized. A beacon includes the *Net_ID (ESS)*, the access point address, the Broadcast destination addresses, a time stamp, a *DTIM (Delivery Traffic Indicator Maps)* and the *TIM (Traffic Indicator Message)*.

PSP (Power Save Polling) stations power off their radios for long periods. When a MU in PSP mode associates with an access point, it notifies the access point of its activity status. The access point responds by buffering packets received for the MU. The adapters use a PSP performance index from 1 to 5, where 1 provides the quickest response time and 5 provides the most efficient power consumption.

The performance index determines how long the adapter stays in CAM after transmit or receive activity. Regardless of the performance index used, adapters switch to CAM for data reception/transmission. The awake interval in PSP performance index 1 is long enough to allow for round-trip packet response times. The packet response time in PSP performance index 5 is only 25 msec, the adapter goes back to sleep and requires another wake up period to receive data.

When the MU wakes up and sees its bit set in the TIM, it issues a short frame to the access point for the packets stored. The access point sends them to the MU and the MU issues another short frame when the data has been received and is ready to go back to PSP. A DTIM field, also called a countdown field, informs MUs of the next window for listening to broadcast and multicast messages. When the access point has buffered broadcast or multicast messages for associated MUs, it sends the next DTIM with a *DTIM Interval* value. To prevent a PSP-mode MU from sleeping through a DTIM notification, select a PSP mode value less than or equal to the DTIM value. PSP-mode MUs hear the beacons and awaken to receive the broadcast and multicast messages.

A TIM is a compressed virtual bitmap identifying the access point associated MUs in PSP mode that have buffered directed messages. MUs issue a poll request when access points issue a TIM. A beacon with the broadcast-indicator bit set causes the MU to note *DTIM Count* field value. The value informs the MU of the beacons remaining before next DTIM. This ensures the MU turns on the receiver for the DTIM and the following *BC/MC packet transmissions*.

A.3.10 Data Encryption

Intel® PRO/Wireless 2011 LAN devices operating on a wired or wireless network face possible information theft. This occurs when an unauthorized user eavesdrops on someone else to obtain information illegally. The absence of a physical connection makes wireless links particularly vulnerable to this form of theft. *Encryption* becomes the most efficient method in preventing information theft and improving data security. Encryption entails scrambling and coding information, typically with mathematical formulas called *algorithms*, before the information is transmitted over a network. An algorithm is a set of instructions or formula for scrambling the data. A *key* is the specific code used by the algorithm to encrypt or decrypt the data. *Decryption* is the decoding and unscrambling of received encrypted data. The same device, host computer or front-end processor, usually performs both encryption and decryption. The data transmit or receive direction determines whether the encryption or decryption function is performed. This device takes the plain text and scrambles or encrypts it and transmitting the data over the network, typically by mathematically combining the key with the plain text as prescribed by the algorithm. At the receiving end another device takes the encrypted text and decrypts, unscrambles, the text resulting in the original plain text. An authorized user can know the algorithm, but cannot interpret the encrypted data without the appropriate key. Only the sender and receiver of the transmitted data know the key.

Intel uses the *Wired Equivalent Privacy (WEP)* algorithm, specified in IEEE 802.11 section 8, for encryption and decryption. WEP uses the same key for both encrypting and decrypting plain text. Typically an external key management service distributes the key. Users should change the key often for added security. By default, IEEE 802.11 devices operate in an *open system network* where any wireless device can associate with an access point without authorization. A wireless device with a valid Encryption key is allowed to associate with the access point. *Authentication management messages* (packets) are unicast, meaning authentication messages transmit from one access point to one MU only, not broadcast or multicast.

A.3.11 HTTP, HTML Web Server Support

Hypertext Transfer Protocol (HTTP) is the native language of the Web. The HTTP protocol makes requests from browsers (the user) to servers and responses from servers to browsers. This function provides the user with a Web-based format for configuration and firmware download.

Web pages are written in HTML (Hypertext Markup Language.) HTML allows the user to create web pages containing text, graphics and pointers or links to other web pages or elsewhere on the page or document. Pointers are known as Uniform Resource Locators (URLs). A URL is essentially the name of the web page. The URL consists of three parts:

- the protocol (a scheme)
- the DNS (Domain Name Server) the machine where the page is located
- the local name that identifies the page (usually the file name).

The HTML language describes how to format the document. Much like a copyeditor describes which fonts to use, such as the location, color, header size and text.

A.3.12 Management Options

Managing an Intel® PRO/Wireless 2011 LAN includes viewing network statistics and setting configuration options. Statistics track the network activity of associated MUs and data transfers on the access point interfaces. Configuration involves setting system operating parameters and filters used in bridging.

The access point requires one of the following to perform a custom installation or maintain the Intel® PRO/Wireless 2011 LAN:

- SNMP (Simple Network Management Protocol)
- wired LAN workstation with a Telnet client
- terminal or PC with RS-232 connection and ANSI emulation

Changing one access point does not affect the configuration of other access points on the network. Make configuration changes to access points individually. Each access point requires an individual IP address.

A.3.12.1 Programmable SNMP Trap Support

The SNMP defines the method for obtaining information about networks operating characteristics and changing router and gateway parameters. SNMP consists of three elements:

- management stations
- management information
- a management protocol.

Nodes can perform as hosts, routers, bridges or other devices that can communicate status information. An *SNMP Agent* is a node that runs the SNMP management process to systematically monitor and manage the network. The management station performs network management by running application management software.

An *SNMP trap* is an alert to all configured management stations of some significant event that occurred on the network. The management station queries all stations for details of each specific event, including what, when and where the event took place and the current status of the node or network. The format or structure is defined in SNMP. The MIB defines what and who monitors the variables.

A.3.12.2 Using SNMP

The access point includes *SNMP agent* versions accessible via an SNMP manager application such as, HP Open View or Cabletron Spectrum MIB browser. The SNMP agent supports SNMP versions 1 and 2, MIB II, the 802.11 MIB and one Intel proprietary *MIB (Management Information Base)*. The SNMP agent supports read-write, read-only or disabled modes. The access point supports traps that return to the SNMP manager when certain events occur. The *Wireless LAN Installation and Utilities* disk packaged with MUs contains the MIB.

A.3.12.3 Increased MIB Support

The MIB defines what the management station needs to understand and which objects the station manages. The MIB has ten categories defined with approximately 175 variables.

A.3.12.4 Using the UI

The *UI (User Interface)* is a text-based maintenance tool integrated into the access point. It provides statistical displays, access point configuration options and firmware upgrades. Access to the UI requires one of the following:

| | |
|--------------------------|---|
| Telnet Client | Gain access to the access point built-in Telnet server from any access point interface including remote Ethernet connections. |
| Direct Serial Connection | Acts as a DTE device to connect directly to a DTE device with a null-modem serial cable. The direct serial access method requires a communication program with ANSI emulation. |
| Dial Up Access | The dial-up access method requires a communication program with ANSI emulation on the remote terminal or PC. The terminal or PC dials to an access point with a modem connection. The access point supports connection to a Hayes-compatible 28,800-baud or faster modem. |
| SNMP Via a MIB Browser | Gain access to the access point SNMP function via a MIB Browser. Typically a Network Manager uses this feature, Intel does not recommend access point access using this interface method. Refer to the MIB Browser documentation for usage. |
| Web Browser | Gain access to the access point built-in Web server from any access point interface including remote Ethernet connections. |

For instructions on adjusting the access point configuration options refer to the Product Reference Guide included with the access point.

Appendix B

Customer Support

B.1 Intel Automated Customer Support

You can reach Intel automated support services 24 hours a day, every day at no charge. The services contain the most up-to-date information about Intel products. You can access installation instructions, troubleshooting information, and general product information.

User Guide on Your Product CDROM

For more information about installing drivers or troubleshooting other topics, see the online User Guide. To view the guide, insert the Intel CD in your drive and wait for the Autorun to display. Click the User Guide button to view the guide. Note that a web browser is required to view the guide.

Web and Internet Sites

- Support: <http://support.intel.com>
- Network Products: <http://www.intel.com/network>
- Corporate: <http://www.intel.com>
- Newsgroups: <news://cs.intel.com>
- FTP Host: <download.intel.com>
- FTP Directory: </support/network/adapter/>

Customer Support Technicians

US and Canada: 1-916-377-7000 (7:00 - 17:00 M-F Pacific Time)

Worldwide access: Intel has technical support centers worldwide. Many of the centers are staffed by technicians who speak the local languages. For a list of all Intel support centers, the telephone numbers, and the times they are open, download document 9089 from one of the automated services.

B.2 Software License Agreement

IMPORTANT - READ BEFORE COPYING, INSTALLING OR USING.

Do not use or load this software and any associated materials (collectively, the "Software") until you have carefully read the following terms and conditions. By loading or using the Software, you agree to the terms of this Agreement. If you do not wish to so agree, do not install or use the Software.

LICENSE. You may copy the Software onto a single computer for your personal, non-commercial use, and you may make one back-up copy of the Software, subject to these conditions:

This Software is licensed for use only in conjunction with Intel component products. Use of the Software in conjunction with non-Intel component products is not licensed hereunder.

You may not copy, modify, rent, sell, distribute or transfer any part of the Software except as provided in this Agreement, and you agree to prevent unauthorized copying of the Software.

You may not reverse engineer, decompile, or disassemble the Software.

You may not sublicense or permit simultaneous use of the Software by more than one user.

The Software may contain the software or other property of third party suppliers, some of which may be identified in, and licensed in accordance with, any enclosed "license.txt" file or other text or file.

OWNERSHIP OF SOFTWARE AND COPYRIGHTS. Title to all copies of the Software remains with Intel or its suppliers. The Software is copyrighted and protected by the laws of the United States and other countries, and international treaty provisions. You may not remove any copyright notices from the Software. Intel may make changes to the Software, or to items referenced therein, at any time without notice, but is not obligated to support or update the Software. Except as otherwise expressly provided, Intel grants

no express or implied right under Intel patents, copyrights, trademarks, or other intellectual property rights. You may transfer the Software only if the recipient agrees to be fully bound by these terms and if you retain no copies of the Software.

LIMITED MEDIA WARRANTY. If the Software has been delivered by Intel on physical media, Intel warrants the media to be free from material physical defects for a period of ninety (90) days after delivery by Intel. If such a defect is found, return the media to Intel for replacement or alternate delivery of the Software as Intel may select.

EXCLUSION OF OTHER WARRANTIES. EXCEPT AS PROVIDED ABOVE, THE SOFTWARE IS PROVIDED "AS IS" WITHOUT ANY EXPRESS OR IMPLIED WARRANTY OF ANY KIND INCLUDING WARRANTIES OF MERCHANTABILITY, NON-INFRINGEMENT, OR FITNESS FOR A PARTICULAR PURPOSE.

Intel does not warrant or assume responsibility for the accuracy or completeness of any information, text, graphics, links or other items contained within the Software.

LIMITATION OF LIABILITY. IN NO EVENT SHALL INTEL OR ITS SUPPLIERS BE LIABLE FOR ANY DAMAGES WHATSOEVER (INCLUDING, WITHOUT LIMITATION, LOST PROFITS, BUSINESS INTERRUPTION, OR LOST INFORMATION) ARISING OUT OF THE USE OF OR INABILITY TO USE THE SOFTWARE, EVEN IF INTEL HAS BEEN ADVISED OF THE POSSIBILITY OF SUCH DAMAGES. SOME JURISDICTIONS PROHIBIT EXCLUSION OR LIMITATION OF LIABILITY FOR IMPLIED WARRANTIES OR CONSEQUENTIAL OR INCIDENTAL DAMAGES, SO THE ABOVE LIMITATION MAY NOT APPLY TO YOU. YOU MAY ALSO HAVE OTHER LEGAL RIGHTS THAT VARY FROM JURISDICTION TO JURISDICTION.

TERMINATION OF THIS AGREEMENT. Intel may terminate this Agreement at any time if you violate its terms. Upon termination, you will immediately destroy the Software or return all copies of the Software to Intel.

APPLICABLE LAWS. Claims arising under this Agreement shall be governed by the laws of California, excluding its principles of conflict of laws and the United Nations Convention on Contracts for the Sale of Goods. You may not export the Software in violation of applicable export laws and regulations. Intel is not obligated under any other agreements unless they are in writing and signed by an authorized representative of Intel.

GOVERNMENT RESTRICTED RIGHTS. The Software is provided with "RESTRICTED RIGHTS." Use, duplication, or disclosure by the Government is subject to restrictions as set forth in FAR52.227-14 and DFAR252.227-7013 et seq. or their successors. Use of the Software by the Government constitutes acknowledgment of Intel's proprietary rights therein. Contractor or Manufacturer is Intel Corporation, 2200 Mission College Blvd., Santa Clara, CA 95052.

B.3 Limited Lifetime Hardware Warranty

Intel warrants to the original owner that the adapter product delivered in this package will be free from defects in material and workmanship. This warranty does not cover the adapter product if it is damaged in the process of being installed or improperly used.

THE ABOVE WARRANTY IS IN LIEU OF ANY OTHER WARRANTY, WHETHER EXPRESS, IMPLIED OR STATUTORY, INCLUDING BUT NOT LIMITED TO ANY WARRANTY OF NONINFRINGEMENT OF INTELLECTUAL PROPERTY, MERCHANTABILITY, FITNESS FOR A PARTICULAR PURPOSE ARISING OUT OF ANY PROPOSAL, SPECIFICATION, OR SAMPLE.

This warranty does not cover replacement of adapter products damaged by abuse, accident, misuse, neglect, alteration, repair, disaster, improper installation, or improper testing. If the adapter product is found to be defective, Intel, at its option, will replace or repair the hardware product at no charge except as set forth below, or refund your purchase price provided that you deliver the adapter product along with a Return Material Authorization (RMA) number (see below), along with proof of purchase (if not registered), either to the dealer from whom you purchased it or to Intel with an explanation of any deficiency. If you ship the adapter product, you must assume the risk of damage or loss in transit. You must use the original container (or the equivalent) and pay the shipping charge.

Intel may replace or repair the adapter product with either new or reconditioned parts, and any adapter product, or part thereof replaced by Intel becomes Intel property. Repaired or replaced adapter products will be returned to you at the same revision level as received or higher, at Intel's option. Intel reserves the right to replace discontinued adapter products with an equivalent current generation adapter product.

Returning a defective product

From North America:

Before returning any adapter product, contact Intel Customer Support and obtain a Return Material Authorization (RMA) number by calling +1 916-377-7000.

If the Customer Support Group verifies that the adapter product is defective, they will have the RMA department issue you an RMA number to place on the outer package of the adapter product. Intel cannot accept any product without an RMA number on the package.

All other locations:

Return the adapter product to the place of purchase for a refund or replacement.

Intel Adapter Money-back Guarantee (North America Only)

Intel wants you to be completely satisfied with the Intel adapter product that you have purchased. Any time within ninety (90) days of purchase, you may return your Intel adapter to the original place of purchase for a full refund of the purchase price from your dealer. Resellers and distributors, respectively, accepting returns and refunding money back to their customers may return Intel adapters to their original place of purchase. Intel guarantees that it will accept returns under this policy and refund the original purchase price to customers purchasing directly from Intel.

Limitation of Liability and Remedies

INTEL'S SOLE LIABILITY HEREUNDER SHALL BE LIMITED TO DIRECT, OBJECTIVELY MEASURABLE DAMAGES. IN NO EVENT SHALL INTEL HAVE ANY LIABILITY FOR ANY INDIRECT OR SPECULATIVE DAMAGES (INCLUDING, WITHOUT LIMITING THE FOREGOING, CONSEQUENTIAL, INCIDENTAL, AND SPECIAL DAMAGES) INCLUDING, BUT NOT LIMITED TO, INFRINGEMENT OF INTELLECTUAL PROPERTY, REPROCUREMENT COSTS, LOSS OF USE, BUSINESS INTERRUPTIONS, LOSS OF GOODWILL, AND LOSS OF PROFITS, WHETHER ANY SUCH DAMAGES ARISE OUT OF CONTRACT NEGLIGENCE, TORT, OR UNDER ANY WARRANTY, IRRESPECTIVE OF WHETHER INTEL HAS ADVANCE NOTICE OF THE POSSIBILITY OF ANY SUCH DAMAGES. NOTWITHSTANDING THE FOREGOING, INTEL'S TOTAL LIABILITY FOR ALL CLAIMS UNDER THIS AGREEMENT SHALL NOT EXCEED THE PRICE PAID FOR THE PRODUCT. THESE LIMITATIONS ON POTENTIAL LIABILITIES WERE AN ESSENTIAL ELEMENT IN SETTING THE PRODUCT PRICE. INTEL NEITHER ASSUMES NOR AUTHORIZES ANYONE TO ASSUME FOR IT ANY OTHER LIABILITIES.

Some states do not allow the exclusion or limitation of incidental or consequential damages, so the above limitations may not apply to you.

Critical Control Applications: Intel specifically disclaims liability for use of the adapter product in critical control applications (including, for example only, safety or health care control systems, nuclear energy control systems, or air or ground traffic control systems) by Licensee or Sublicensees, and such use is entirely at the user's risk. Licensee agrees to defend, indemnify, and hold Intel harmless from and against any and all claims arising out of use of the adapter product in such applications by Licensee or Sublicensees.

Software: Software provided with the adapter product is not covered under the hardware warranty described above. See the applicable software license agreement which shipped with the adapter product for details on any software warranty.

Appendix C

Regulatory Compliance

To comply with U.S. and international regulatory requirements, the following information has been included. The document applies to the complete line of Intel products. Some of the labels shown, and statements applicable to other devices might not apply to all products.

Radio Frequency Interference Requirements

This device has been tested and found to comply with the limits for a Class A digital device pursuant to Part 15 of the Federal Communications Commissions Rules and Regulation. These limits are designed to provide reasonable protection against harmful interference when the equipment is operated in a commercial environment. This equipment generates, uses, and can radiate radio frequency energy and, if not installed and used in accordance with the instruction manual, may cause harmful interference to radio communications. Operation of this equipment in a residential area is likely to cause harmful interference in which case the user will be required to correct the interference at his own expense.

However, there is no guarantee that interference will not occur in a particular installation. If the equipment does cause harmful interference to radio or television reception, which can be determined by turning the equipment off and on, the user is encouraged to try to correct the interference by one or more of the following measures:

- Re-orient or relocate the receiving antenna.
- Increase the separation between the equipment and receiver.
- Connect the equipment into an outlet on a circuit different from that which the receiver is connected.
- Consult the dealer or an experienced radio/TV technician for help.

Radio Frequency Interference Requirements - Canada

This Class A digital apparatus meets the requirements of the Canadian Interference-Causing Equipment Regulations.

CE Marking & European Union Compliance



Products intended for sale within the European Union are marked with the CEMark which indicates compliance to applicable Directives and European Normes (EN), as follows. Amendments to these Directives or ENs are included: Normes (EN), as follows.

Applicable Directives:

- Electromagnetic Compatibility Directive 89/336/EEC
- Low Voltage Directive 73/23/EEC

Applicable Standards:

- EN 55 022 - Limits and Methods of Measurement of Radio Interference Characteristics of Information technology Equipment
- EN 50 082-1 - Electromagnetic Compatibility - Generic Immunity Standard, Part 1: Residential, commercial, Light Industry
- IEC 801.2 - Electromagnetic Compatibility for Industrial Process Measurement and Control Equipment Part 2: Electrostatic Discharge Requirements
- IEC 801.3 - Electromagnetic Compatibility for Industrial Process Measurement and Control Equipment Part 3: Radiated Electromagnetic Field Requirements
- IEC 801.4 - Electromagnetic Compatibility for Industrial Process Measurement and Control Equipment Part 4: Electrical Fast Transients Requirements
- EN 60 950 + Amd 1 + Amd 2 - Safety of Information Technology Equipment Including Electrical Business Equipment
- EN 60 825-1 (EN 60 825) - Safety of Devices Containing Lasers

RF Devices

Intel RF products are designed to be compliant with the rules and regulations in the locations into which they are sold and will be labeled as required. The majority of Intel's RF devices are type approved and do not require the user to obtain license or authorization before using the equipment. Any changes or modifications to Intel equipment not expressly approved by Intel could void the user's authority to operate the equipment.

Telephone Devices (Modems)

United States

If this product contains an internal modem it is compliant with Part 68 of the Federal Communications Commission Rules and Regulations and there will be a label on the product showing the FCC ID Number and the REN, Ringer Equivalence Number. The REN is used to determine the quantity of devices which maybe connected to the telephone line. Excessive RENs on the telephone line may result in the device not ringing in response to an incoming call. In most but not all areas, the sum of the RENs should not exceed 5.0. To be certain of the number of devices that may be connected to the line, as determined by the total number of RENs, contact the telephone company to determine the maximum REN for the calling area.

If the modem causes harm to the telephone network, the telephone company will notify you in advance; however, if advance notice is not practical, you will be notified as soon as possible. Also, you will be advised of your right to file a complaint with the FCC if you believe it is necessary.

The telephone company may make changes in its facilities, equipment, operations or procedures that could affect the operation of the modem. If this happens the telephone company will provide advance notice so you may make any necessary modifications to maintain uninterrupted service.

Canada

If this product contains an internal modem it is compliant with CS-03 of Industry Canada and there will be a Canadian certification number (CANADA: _____) on a label on the outside of the product. This certification means that the equipment meets certain telecommunications network protective, operational and safety requirements. The Department does not guarantee the equipment will operate to the user's satisfaction.

Before installing this equipment, users should ensure that it is permissible to be connected to the facilities of the local telecommunications company. The equipment must also be installed using an acceptable method of connection. In some cases, the company's inside wiring associated with a single-line, individual service maybe extended by means of a certified convector assembly (telephone extension cord). The customer should be aware that compliance with the above conditions may not prevent degradation of service in some situations.

Repairs to certified equipment should be made by an authorized Canadian maintenance facility designated by the supplier. Any repairs or alterations made by the user to this equipment, or equipment malfunctions, may give the telecommunications company cause to request the user to disconnect the equipment.

User should ensure for their own protection that the electrical ground connections of the power utility, telephone lines and internal metallic water pipe system, if present, are connected together. This precaution may be particularly important in rural areas.



User should not attempt to make such connections themselves, but should contact the appropriate electric inspection authority, or electrician, as appropriate.

The Load Number (LN) assigned to each terminal device denotes the percentage of the total load to be connected to the telephone loop which is used by the device, to prevent overloading. The termination of a loop may consist of any combination of devices, subject only to the requirement that the total of the Load Numbers of all devices not exceed 100.

The Load Number is located on a label on the product.

Si ce produit contient un intérieur modem duquel est conformité avec le code CS-03 de l'industrie canadien alors il aura un numéro de la certification canadienne (CANADA: _____) sur l'étiquette affiché au produit. L'étiquette d'Industrie Canada a identifiée le matériel homologué. Cette étiquette a certifiée que le matériel est conformé aux certaines normes de protection, d'exploitation et de sécurité des réseaux de télécommunications. Toutefois, le Ministère n'assure pas que le matériel fonctionnera à la satisfaction de l'utilisateur.

Avant d'installer ce matériel, l'utilisateur doit assurer qu'il soit permis de raccorder aux installations de l'entreprise télécommunications locales. Le matériel doit être également installé au suivant d'une méthode de raccordement. Dans certains cas, les fils intérieurs de l'entreprises utilisés pour un service individuel à la ligne unique peuvent être prolongés au moyen d'un dispositif de raccordement homologué (cordon rallongé téléphonique interne). L'abonné ne doit pas oublier qu'il est possible que la conformité aux conditions énoncées ci-dessus n'empêchent pas la dégradation du service dans les certaines situations. Actuellement, les entreprises de télécommunication ne permettent pas que l'on raccorde leur matériels à des jacks d'abonnés, sauf dans les cas précis et prévus pas les tarrifs particuliers de ces entreprises.

Les réparations de matériel homologué doivent être effectuées par un centre d'entretien canadien autorisé par le fournisseur. La compagnie de télécommunications peut demander à l'utilisateur de débrancher un appareil à la suite des réparations ou des modifications effectuées par l'utilisateur, ou à cause des mauvais fonctionnement.

Pour sa propre protection, l'utilisateur doit assurer que tous les fils de mise à terre de la source d'énergie électrique, lignes téléphoniques et les canalisations d'eau métalliques, s'il y en a, soient raccordés ensemble. Cette précaution est particulièrement importante dans les régions rurales.



AVERTISSEMENT: L'utilisateur ne doit pas tenter de faire ces raccordements lui-même; il doit avoir recours aux services d'électronicien.

L'indice de charge (IC) assigné à chaque dispositif terminal indique, pour éviter toute surcharge, le pourcentage de la charge totale qui peut être raccordé au circuit téléphonique bouclé d'utiliser par ce dispositif. La terminaison du circuit bouclé peut être constituée de n'importe quelle combinaison de dispositifs, pourvu que la somme des indices de charge dans l'ensemble des dispositifs ne dépassent pas 100.

L'indice de charge se trouve sur le produit.

Laser Devices

Intel products using lasers comply with US 21CFR1040.10, Subchapter J and IEC825/EN 60 825 (or IEC825-1/EN 60 825-1, depending on the date of manufacture). The laser classification is marked one of the labels on the product.

Class 1 Laser devices are not considered to be hazardous when used for their intended purpose. The following statement is required to comply with US and international regulations:



Use of controls, adjustments or performance of procedures other than those specified herein may result in hazardous visible or invisible laser light exposure.

Class 2 laser scanners use a low power, visible light diode. As with any very bright light source, such as the sun, the user should avoid staring directly into the light beam. Momentary exposure to a Class 2 laser is not known to be harmful.

Index

A

access point

- ACL A-9
- antenna placement 3
- association process A-19
- BSS_ID A-5
- CAM A-23
- CCA A-19
- cellular coverage A-4
- coverage considerations 3
- DHCP A-10
- direct-sequence A-16
- diversity reception 7
- encryption A-25
- ESS A-5
- interference considerations 4
- MAC address A-8
- media types A-11
- Mobile IP A-21
- mobile units A-6
- Net_ID A-5
- network topologies A-2
- PPP A-15
- radio basics A-2
- signal strength 11

antenna

- AP A-6
- carrier signal A-2
- cellular coverage A-4
- coverage requirements 5
- directional 5
- direct-sequence 4

diversity 7

- omnidirectional 5
- placement 3
- signal loss 3
- signal strength 11

AP features

- ACL A-9
- bridging support A-12
- decryption A-25
- DHCP support A-10
- encryption A-25
- IEEE 802.11 A-11
- Mobile IP A-21
- SNMP trap support A-28
- Web server support A-26

Area menu

- edit area 40
- FTP Test 46
- ICMP Test 41
- logfile 41
- name and description 39
- navigating 38
- notes 41
- text file 41

association process

- beacon A-23
- DTIM A-24

B

beacon A-23

- CAM stations A-23
- PSP stations A-23
- TIM A-24

C

- creating a workspace
 - File menu **17**
 - new area **39**
 - Site Survey dialog box **18**
 - surveyor **18**
 - workspace name **18**
- customer support technicians **B-2**

D

- direct-sequence
 - antennas **4**
 - AP **A-6**
 - cellular coverage **A-4**
 - channel **4**
 - chipping sequence **A-16**
 - data rate **A-17**
 - interference **4**
 - products **A-1**
 - spread spectrum **A-16**
 - spreading ratio **A-17**

E

- Edit menu
 - area **23**
 - default settings **24**
 - Logging property page **28**
 - Meter Settings property page **26**
 - navigating **21**
 - Setup property page **24**
 - Sounds property page **27**
- editing
 - default settings **24**
 - existing survey area **40**
 - FTP test parameters **46**
 - ICMP test parameters **42**

- information **22**
- Logging property page **28**
- Meter Settings property page **26**
- note file **41**
- properties **23**
- property pages **24**
- report **37**
- Setup property page **24**
- Sounds property page **27**

- electrical considerations
 - AP power **8**
 - ground circuit **7**
 - hard wired devices **8**
 - surge suppressor **7**
 - UPS **7**
 - wall outlets **7**
- existing survey area
 - area list **40**
 - data rate **32**
 - editing **23**
 - note file **41**
 - remove **23**
 - report **37**
 - tests **40**

F

- File menu
 - displaying surveys **21**
 - existing site survey **18**
 - import **20**
 - new area **19**
 - new site survey **18**
 - reports **20**
- frequency-hopping
 - graph **34**
 - logfile **34**

- noise meter **34**
- RSSI **34**
- spread spectrum **34**

I

ICMP test

- AP **42**
- area **42**
- edit note **42**
- host address **45**
- logging **45**
- packet size **44**
- parameters **42**
- ping count **44**
- progress bars **43**
- results **42**
- statistics **42**
- threshold **43**

importing

- areas and tests **20**

installing utility

- CDROM **12**
- desktop computer **12**
- Intel Web site **12**

Intel automated customer support **B-1**

Intel web sites **B-1**

L

Logging property page

- clear log **28**
- logfile **28**
- logging **28**

M

Meter Settings property page

- bounds **26**
- threshold **26**

mobile unit (MU)

- ACL **A-9**
- adapter Info **30**
- AP **A-6**
- association process **A-19**
- association table **A-5**
- BSS_ID **A-4**
- CAM **A-23**
- CCA **A-19**
- cellular coverage **A-4**
- coverage considerations **3**
- direct-sequence **4, A-16**
- diversity reception **7**
- ESS **A-5**
- Mobile IP **A-21**
- Net_ID **A-5**
- network topologies **A-2**
- noise meter **34**
- PSP **A-23**
- radio basics **A-2**
- RSSI **34**
- signal quality **29, 36**
- SNMP **A-28**
- transmission rate **32**

MU

- CAM **A-23**
- DTIM **A-24**

N

new site survey

- area **19**
- importing **20**
- report **20**
- site survey dialog box **18**

note file

- entering notes **42**

open survey area 41

P

product warranty B-2

PSP stations A-23

beacon A-23

MU A-23

R

regulatory compliance C-1

regulatory notices B-2

roaming across routers

TIM A-23

S

Setup property page

default ICMP address 24

ICMP host address 25

packet size 25

ping 25

rerun 24

surveyor 24

Threshold 25

signal quality

antenna placement 5

AP 36

AP info 32

coverage considerations 3

data rates 32

diversity reception 7

ICMP Test 41

interference considerations 4

meter settings 26

MU 36

site survey results 37

throughput tests 46

Site Survey

antenna placement 5

AP A-6

association process A-19

CAM A-23

cellular coverage A-4

considerations 2

coverage considerations 3

DHCP A-10

direct-sequence 4, A-16

electrical considerations 7

encryption A-25

installation 12

Intel PRO/Wireless 2011 LAN 1

Intel PRO/Wireless overview A-1

interference considerations 4

Mobile IP A-21

network topologies A-2

preparation 1

radio basics A-2

requesting 8

scheduling 9

site survey inspection 2

SNMP A-28

starting 15

trial installation areas 2

utility 11

Site Survey report

considerations 37

findings 37

generation 20

placement recommendations 37

warranty information 37

Site Survey Utility

installation 12

navigating 17

starting 15

software license agreement **B-2**

Sounds property page

ping **27**

roam **27**

threshold time **27**

timeout **27**

survey area inspection

coverage requirements **5**

diversity **7**

electrical **7**

requirements **2**

variables **3**

T

test parameters

anonymous login **46**

AP **42**

area **42**

new **44**

password **47**

setting FTP **46**

setting ICMP **42**

site name **46**

user name **47**

tests

FTP **46**

FTP parameters **46**

ICMP **41**

ICMP parameters **42**

progress bars **43**

throughput tests

anonymous login **46**

FTP run count **47**

FTP site name **46**

parameters **46**

password **47**

results **47**

subdirectory **47**

username **47**

transmission rate

1 Mbit **32**

11 Mbit **32**

11 Mbps **A-11, A-17**

2 Mbit **32**

5.5 Mbit **32**

adapter Info **30**

AP **32**

association process **A-19**

MU **32**

radio basics **A-2**

V

View menu

access point info **32**

adapter info **30**

area info **31**

navigating **29**

noise info **34**

signal quality **36**

viewing

MU signal quality **36**

noise meter **34**

RSSI values **34**

W

Welcome dialog box

Area menu **16**

Edit menu **16**

existing site survey **15**

File menu **16**

new workspace **15**

View menu **16**

workspace template 15